

U. S. COMMISSION OF FISH AND FISHERIES,
JOHN J. BRICE, Commissioner.

PART XXIII.

REPORT

OF

THE COMMISSIONER

FOR

THE YEAR ENDING JUNE 30, 1897.

*Rare BK
SH
11
A15
1897*

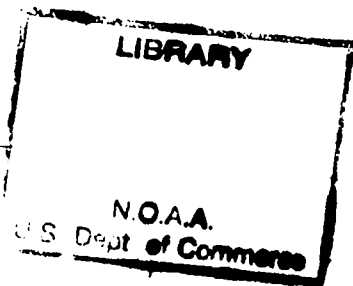

WASHINGTON:
GOVERNMENT PRINTING OFFICE.

1898.

**NOBIAK MARINE FISHERIES CENTER
LIBRARY**

National Oceanic and Atmospheric Administration

Report of the United States Commissioner of Fisheries

ERRATA NOTICE

One or more conditions of the original document may affect the quality of the image, such as:

Discolored pages

Faded or light ink

Binding intrudes into the text

This has been a co-operative project between the NOAA Central Library and the National Marine Fisheries Service (NOAA Fisheries). To view the original document, please contact the NOAA Central Library in Silver Spring, MD at (301) 713-2607 x124 or www.reference@nodc.noaa.gov.

LASON

Imaging Contractor

12200 Kiln Court

Beltsville, MD 20704-1387

November 19, 2004

CONTENTS.

2500

880 Xf

Report of the Commissioner.....	v-xvii
Report on the Propagation and Distribution of Food-fishes. By W. deC. Ravenel.....	xviii-xc
Report of the Division of Scientific Inquiry. By Hugh M. Smith....	xcI-cxxiv
Report of the Division of Statistics and Methods of the Fisheries. By Hugh M. Smith.....	cxxv-clxvi
Report on the Work of the Albatross. (Abstract.) By J. F. Moser, Lieut. Commander, U. S. Navy.....	clxvii-clxxi

APPENDIX.

100 July 18

Albatross

A Manual of Fish-culture, based on the Methods of the United States Commission of Fish and Fisheries, with Chapters on the Cultivation of Oysters and Frogs (Plates 1-62 and I-xviii).....	1-340
--	-------

III

R E P O R T
OF THE
UNITED STATES COMMISSIONER OF FISH AND FISHERIES
FOR THE
FISCAL YEAR ENDING JUNE 30, 1897.

I have the honor to submit a report of the operations of the United States Commission of Fish and Fisheries for the year ending June 30, 1897, with reports from the assistants in charge of its different divisions, showing the work in detail, together with an appendix describing the methods of fish-culture pursued by the Commission.

The work of the Division of Fish-Culture has been very satisfactory, showing a gratifying increase in the propagation and distribution of the important food-fishes. In addition to the stations mentioned last year, those at San Marcos, Tex., Manchester, Iowa, and Bozeman, Mont., have been completed and are now in operation.

Attention has been paid to carrying out the policy outlined in my former report, of increasing the production of the commercial species propagated by the Commission on the Atlantic and Pacific coasts and the Great Lakes, by establishing auxiliary hatcheries in connection with the permanent stations, for the extension of the field for the collection of eggs. The use of Battle Creek Station, Shasta County, Cal., obtained through the cooperation of the California Fish Commission, resulted in the collection of over 25,000,000 salmon eggs in addition to the 5,000,000 collected at Baird Station. In the Columbia River Basin the plants of fry were increased by the establishment of temporary stations on the Salmon River in Oregon and the Little White Salmon River in Washington, the two stations yielding over 4,700,000 eggs.

The total collection at the Pacific stations, amounting to 37,000,000, was over three times greater than the collection of any previous season. 5,000,000 quinnat-salmon eggs were transferred to eastern stations, and the fry resulting from them were planted in the Hudson, Delaware, and St. Lawrence rivers, New York, and the Penobscot and Union rivers, Maine. Additional assignments of steelhead eggs were also sent east, and plants of the fry were made in the Penobscot and Hudson rivers and tributaries of Lakes Michigan and Superior.

The cod work at the Massachusetts stations was the most extensive ever accomplished by the Commission, over 178,000,000 eggs being collected. 97,419,000 fry were hatched and liberated on the natural spawning-grounds by means of the steamer *Fish Hawk* and sailing vessels chartered for the purpose.

For the maintenance of the lobster fishery, which has been steadily declining for a number of years, it was arranged not only to cover the region in the vicinity of Woods Hole and Gloucester stations, but also to make systematic collections of eggs from fishermen between Rockland, Me., and Noank, Conn. The schooner *Grampus* was utilized on the Maine coast for the collection of eggs and the liberation of fry, and the steamer *Fish Hawk* was employed as a floating hatchery at Casco Bay. Agents were stationed at Kittery, Me.; Boston, Plymouth, and New Bedford, Mass., and points in Connecticut, who collected egg lobsters for transportation to the hatcheries of Gloucester and Woods Hole. As a result of this extension of the work, over 128,000,000 eggs were secured and 115,606,000 fry planted. During the spring and summer particular attention was paid to the food, habits, and growth of the young lobster, and much valuable information was obtained at Woods Hole, where experiments were conducted in the holding of the fry during the molting stages.

Preliminary to the establishment of auxiliary shad-hatcheries on the South Atlantic Coast, the *Fish Hawk* was detailed early in the winter to make investigations on certain important rivers in that section for the purpose of determining their value as collecting fields for eggs. Proceeding to Palatka, Fla., the vessel was anchored at the mouth of the Ocklawaha River and arrangements were made to collect eggs from fishermen operating on the St. Johns between Welaka and Sanford, where most of the fishing is done. Large numbers of shad were taken daily in the nets and seines, and valuable information with reference to their habits and movements was obtained, but only three or four ripe fish were secured. At the end of March the vessel proceeded to Albemarle Sound and commenced operations at Avoca, N. C., at the mouth of the Chowan River. The work at that point resulted in the collection of over 27,000,000 shad eggs and the liberation of 16,000,000 fry at the head of the sound. During the months of April, May, and June the usual shad operations were conducted on the Delaware, Potomac, and Susquehanna rivers, the total collection of eggs for the season resulting in a distribution of 134,545,500 yearlings, fry, and eggs. From the experience gained this year there is little doubt that the collection of shad eggs can be largely increased by the establishment of auxiliary stations on other rivers of the South Atlantic Coast.

The work on the Great Lakes was attended with good results, though the collection of eggs was seriously interfered with by severe gales, which destroyed the fishing gear during the spawning season. Over 18,000,000 lake-trout eggs were secured on Lakes Superior, Michigan, Huron, and Ontario, besides 126,000,000 whitefish eggs on Lakes Huron, Michigan, and Erie; 13,509,000 yearlings, fry, and eggs of the lake trout and 95,049,000 whitefish fry were distributed.

At the interior stations devoted to the production of trout, bass, and crappie the work of restocking inland streams and lakes has progressed satisfactorily.

In continuation of the experiments of previous years, to introduce lobsters and eastern oysters on the Pacific coast, 20 adult male lobsters and 69 females, with eggs, were taken from New England and liberated near Monterey, Cal., in November, 1896, and at the same time 25 barrels of 3-year-old oysters were planted on suitable grounds in Humboldt Bay, near Eureka, Cal., and an equal number in Yaquina Bay, Oregon. On the same trip 129 diamond-backed terrapin from Chesapeake Bay and South Carolina were planted in San Francisco Bay under the direction of the California Fish Commission.

The following table shows the numbers of fish and eggs furnished for distribution by the various stations:

Source of supply.	Species.	Eggs.	Fry and fingerlings.	Adults and yearlings.
Green Lake, Me.	Landlocked salmon	77,000	61,000	2,164
	Atlantic salmon		33,000	
	Quinnat salmon	30,000	894,500	
	Brook trout	40,000	50,000	769
	Von Behr trout			
Craig Brook, Me.	Golden trout	10,000	35,000	
	Atlantic salmon	390,000	1,053,671	235,172
	Landlocked salmon			10,886
	Quinnat salmon		916,449	7,401
	Brook trout			2,219
	Rainbow trout			11,552
	Lake trout			10,411
St. Johnsbury, Vt.	Swiss lake trout			36,342
	Von Behr trout			651
	Steelhead trout		55,750	11,270
	Atlantic salmon		1,341	
	Quinnat salmon		238,044	
	Brook trout	140,000	495,400	
	Steelhead trout		10,000	
Gloucester, Mass.	Lobster		47,869,000	
	Cod		62,305,000	
Woods Hole, Mass.	Mackerel		652,000	
	Lobster		64,419,000	
	Cod		35,953,000	
	Flatfish		64,095,000	
	Tautog		624,000	
Cape Vincent, N. Y.	Sea bass		193,000	
	Rainbow trout		18,000	
	Lake trout		1,200,000	
	Steelhead trout		10,000	
	Quinnat salmon		1,058,000	
	Atlantic salmon		48,000	
	Whitefish		750,000	
Steamer Fish Hawk	Shad	3,230,000	58,004,500	
	Lobster		4,610,065	
Battery Island, Md.	Shad	1,294,000	50,862,000	
	Striped bass		450,000	
Fish Lakes, D. C.	Black bass, large-mouth			38,492
	Black bass, small-mouth			2,688
	Rock bass			5,070
	Shad			1,500,000
Central Station, D. C.	Brook trout		2,202	
	Rainbow trout		7,479	
	Loch Leven trout		2,209	
	Lake trout		4,338	
	Quinnat salmon		7,516	
	Shad	2,070,000	25,346,000	
Bryan Point, Md.	do	30,707,000		
	Rainbow trout	245,000	120,000	79,754
Wytheville, Va.	Black bass, large-mouth			55
	Rock bass			11,615
	Whitefish		60,309,000	
Put-in Bay, Ohio	Lake trout		794,400	
	Lake herring		7,299,000	
	Black bass, small-mouth			31
Northville, Mich.	Lake trout	1,252,000	5,280,000	
	Brook trout	12,000	97,500	
	Rainbow trout		6,500	
	Loch Leven trout	2,000	15,000	
	Steelhead trout		32,000	
Alpena, Mich.	Whitefish		32,000,000	

* 2,810,000 planted in Delaware River, New Jersey; 411,000 sent to Nashville Exposition.
 † Shad eggs sent to Nashville Exposition.

VIII REPORT OF COMMISSIONER OF FISH AND FISHERIES.

Statement of fish and eggs furnished for distribution, etc.—Continued.

Source of supply.	Species.	Eggs.	Fry and fingerlings.	Adults and yearlings.
Duluth, Minn.	Steelhead trout		74,000	
	Lake trout		4,769,000	
	Brook trout		15,400	
	Rainbow trout		200	
Quincy, Ill.	Whitefish		1,990,000	
	Black bass, large-mouth			32,375
	Crappie			3,418
	Yellow perch			1,025
Manchester, Iowa	Pickereel			1,700
	Rainbow trout		41,222	
	Lake trout		158,000	
Neosho, Mo.	Rainbow trout	90,200	27,000	60,125
	Black bass, large-mouth			15,690
	Rock bass			32,940
San Marcos, Tex.	Strawberry bass			5,129
	Black bass, large-mouth			11,750
Leadville, Colo.	Loch Leven trout	30,000		500
	Rainbow trout	5,000	27,500	
	Black-spotted trout	5,000	42,200	
	Brook trout	140,000	287,000	94,000
Baird, Cal.	Yellow-fin trout		7,931	
	Quinnat salmon	4,337,500	1,906,088	
Port Gaston, Cal.	do		280,250	
	Silver salmon		124,750	
	Rainbow trout		22,000	30,000
	Von Behr trout		22,100	275
Korbel, Cal.	Steelhead trout	50,000	202,000	
	Quinnat salmon		145,365	
	Silver salmon		173,387	
	Steelhead trout		55,000	
Battle Creek, Cal.	Quinnat salmon	13,895,000		
Bear Valley, Cal.	do		635,000	
Clackamas, Oreg.	do		4,042,634	
Salmon River station, Oreg.	do		100,000	
Little White Salmon River station, Wash.	do		1,848,760	
Mapleton, Oreg.	do		180,000	

The following table shows, by species, the fish and eggs distributed by the Commission during the year:

Species.	Eggs.	Fry.	Adults and yearlings.	Total.
Shad	2,819,000	130,226,500	1,500,000	134,545,500
Quinnat salmon	18,262,500	13,884,261	7,198	32,104,049
Atlantic salmon	300,000	1,705,010	234,789	2,329,809
Landlocked salmon	77,000	61,000	12,566	150,566
Silver salmon		298,137		298,137
Steelhead trout	50,000	439,045	10,045	499,090
Loch Leven trout	32,000	17,209	500	49,709
Rainbow trout	341,200	254,801	172,122	768,123
Von Behr trout		22,100	1,680	23,780
Black-spotted trout		42,200		42,200
Brook trout	332,000	943,004	84,500	1,359,510
Lake trout	1,252,000	12,247,738	9,411	13,509,149
Swiss lake trout			36,082	36,082
Yellow-fin trout		7,930		7,930
Golden trout	10,000	35,000		45,000
Whitefish		95,049,000		95,049,000
Yellow perch			1,025	1,025
Pickereel			1,700	1,700
Striped bass		450,000		450,000
Lake herring		7,299,000		7,299,000
Black bass (large-mouth)			95,358	95,358
Black bass (small-mouth)			2,719	2,719
Crappie			2,125	2,125
Rock bass			42,687	42,687
Strawberry bass			3,120	3,120
Codfish		98,258,000		98,258,000
Flatfish		64,095,000		64,095,000
Lobster		115,606,065		115,606,065
Tantog		624,000		624,000
Mackerel		652,000		652,000
Sea bass		193,000		193,000
Total	23,565,790	542,360,000	2,218,252	568,144,042

NOTE.—3,030,000 shad fry were released in the fish-ponds at Washington, D. C., for rearing, and are not to be included in the summation.

The distributing cars traveled 87,550 miles during the year, and detached messengers traveled 119,055 miles, in the distribution of the fishes liberated.

The Commission is under continued obligations to various railroads in the United States for free transportation furnished during the year, as shown in the following statement:

Name of railroad.	Cars.	Messen- gers.	Name of railroad.	Cars.	Messen- gers.
	Miles.	Miles.		Miles.	Miles.
Ann Arbor Railroad	400		Kansas City, Fort Scott and Memphis	432	
Atchison, Topeka and Santa Fe	3,717		Kansas City, Pittsburg and Gulf	308	640
Baltimore and Ohio Railroad		562	Louisville and Nashville Rail- road	3,616	
Baltimore and Ohio Southwestern		65	Maine Central Railroad	2,436	90
Bangor and Aroostook Railroad	148		Michigan Central Railroad	4,866	
Boston and Maine Railroad		954	Mobile and Ohio Railroad	1,018	
Burlington and Missouri River, in Nebraska	1,288	104	Montana Union Railroad	116	
Burlington, Cedar Rapids and Northern	1,754	2,101	Montpelier and Wells River Railroad		188
Central Vermont Railroad	123	80	Minneapolis, St. Paul and Sault Ste. Marie Railroad	126	
Chicago and West Michigan	1,007		Nashville, Chattanooga and St. Louis		151
Chicago, Burlington and Quincy	1,872	3,629	New York, New Haven and Hartford		69
Chicago, Milwaukee and St. Paul		272	New York, Ontario and Western	200	
Chicago, Peoria and St. Louis	292	170	Northern Pacific Railroad	3,020	749
Colorado Midland Railroad	556	584	Oregon Railway and Navigation Co.	934	
Cleveland, Cincinnati, Chicago and St. Louis	3,470		Philadelphia, Reading and New England		58
Cooperstown and Charlotte Val- ley		10	Rutland Railway		376
Chicago and Northwestern Rail- road	353		San Antonio and Aransas Pass	136	
Cheapeake and Ohio Railroad	3,194	457	St. Johnsbury and Lake Cham- plain	230	
Delaware and Hudson River	750	28	St. Louis and San Francisco		1,240
Denver and Rio Grande	354	4,639	Southern Pacific Railroad		256
Denver, Leadville and Gunnison		831	Southern Railway	1,958	151
Detroit and Mackinac Railroad	2,020	188	Texas and Pacific Railroad	180	1,021
Duluth, South Shore and Ath- lantic Railroad	401		Terro Haute and Indianapolis	376	
Flint and Pere Marquette	3,045	645	Union Pacific Railroad	6,112	119
Florida Central and Peninsular	1,124		Union Pacific, Denver and Gulf	154	426
Fromont, Elkhoru and Missouri Valley	351		Vermont Central Railroad		82
Fort Worth and Denver City	444		Wabash Railroad		3,466
Grand Rapids and Indiana	375		West Virginia and Pittsburg		208
Great Northern Railroad	552	430	Wisconsin Central Railroad	402	106
Houston and Texas Central		1,658	Woodstock Railroad		28
Illinois Central Railroad		526			
International and Great North- ern	122	3,619			
Jacksonville, Tampa and Key West	500		Total	55,908	28,084

The scientific work of the Commission has an important bearing on the artificial increase of food-fishes in determining the best methods to pursue in fish-culture, in ascertaining the results of propagation, and in the study of the habits, growth, food, enemies, and diseases of fish. The Division of Scientific Inquiry was under the charge of Mr. Richard Rathbun until December 31, 1896, when, on his resignation to accept the position of assistant secretary of the Smithsonian Institution, Dr. Hugh M. Smith was appointed assistant in charge of that division.

Many special field investigations have been made, besides the usual systematic inquiries covering interior waters.

Field parties, during the summer of 1896, continued the examination of the lakes and streams in Idaho, Washington, Oregon, and California, some of the investigations being the continuation of work begun in previous years. The inquiries have embraced studies of the habits, abundance, distribution, and spawning-grounds of the fishes found in

these waters, special attention being given to the salmon as the important commercial fish of the region. The physical features, including temperature, depth, etc., of the waters, have been studied because of their bearing on fish life, and valuable data obtained. Collections of the fishes, crustaceans, and the other inhabitants of the waters have been made. Investigations were carried on in August and September in the lower Columbia River Basin, in order to determine on a suitable site for an auxiliary hatchery to be operated in connection with the station on the Clackamas River, and a point was selected on the Little White Salmon River where salmon were observed in greatest abundance.

At the request of citizens of New Orleans, an examination of the waters at the mouth of the Pearl River, Mississippi, was made to determine if anything could be done toward increasing the abundance of food and game fishes. Similar investigations were also made in the Sabine and Neches rivers in southeastern Texas, and in the Atchafalaya River, Louisiana; and during the spring and summer months a study was made of the food of the commercial fishes found in Lake Superior. An account of these various investigations and inquiries, as well as of other studies bearing on the subject of fish culture, is found in the appended report of the Division of Scientific Inquiry.

The investigation already begun as to the condition of the coast fisheries of Florida, more particularly the sponge and oyster fisheries, pursuant to Senate resolution of February 15, 1895, has been completed. The report sent to the Senate January 28, 1897, and published, gives an account of the inquiries and the conclusions reached.

The work of the joint commission appointed to investigate the fisheries of the contiguous waters of the United States and Canada, on which Mr. Richard Rathbun, of this Commission, represented the United States, has been completed. The report of the Commissioners was transmitted to Congress by the President February 4, 1897, and certain of the conclusions and recommendations therein are quoted elsewhere in this report (pp. CV-CXVII).

The laboratory of the Commission at Woods Hole was opened as usual in the summer of 1896, its privileges being extended to a number of representatives from well-known educational institutions.

The Commission continues to receive, through its agents and from others interested, reports showing the results of fish-culture, some of which may be mentioned.

While seining the Chesapeake and Ohio Canal during the month of March, 1897, over 4,000 crappie, from $\frac{1}{2}$ to 1 pound in weight, were captured between Little Falls, District of Columbia, and Seneca, Md., and liberated in the Potomac River. These resulted from plants made by the Commission in 1894.

The superintendent of the St. Johnsbury (Vt.) station reports the capture of numbers of rainbow trout in Sleepers River in 1896-97. One of the specimens, captured in May, 1897, was 10 inches long, weighed $\frac{1}{2}$ pound, and contained ripe eggs. Specimens over 5 pounds in weight

were also taken in Otto Creek during the spring of 1897. These are generally found in the lower sections of the streams in deeper water than that usually inhabited by the brook trout. Lake trout were also reported by the same authority as being abundant in Caspian Lake, where plants of that species were made some years ago by the Commission. In certain streams in eastern Tennessee, which have been stocked with rainbow trout within the last few years, excellent fishing is now reported.

The probability of the steelhead trout becoming successfully introduced in many waters of the interior and Eastern States is indicated by the results already attained in some regions. In the spring of 1896 the Commission planted 35,000 fry in Sucker and French rivers, Minnesota, and 50,000 in other streams in that State. Mr. S. P. Wires, superintendent of the station at Duluth, reports, under date of June 14, 1897, that the number and condition of the steelhead trout in the two rivers named warrant the belief that the species is well adapted to that section. On June 13, 1897, 80 steelheads, from 6 to 8 inches long, were caught in Sucker River.

One of the most interesting attempts made by the Commission to secure the introduction of food-fishes into new waters has been the planting of young Atlantic salmon in the Delaware River, in conjunction with the Pennsylvania Fish Commission. In 1895, as shown in the last report of this Commission, over 300 full-grown salmon were taken. In 1896 record of the capture of 142 fish was obtained by the office; these weighed 1,697 pounds. Others were undoubtedly taken and not reported. The outlook for the season of 1897 was considered good, and at the first haul of a large shad seine at Gloucester, N. J., a 15-pound salmon was caught; but the record for the year was poor.

The cod fishermen of Massachusetts, with practical unanimity, ascribe their successful fishing on parts of the coast to the work of the Gloucester and Woods Hole hatcheries. The "rip fishing," which has apparently been established and maintained by the very large plants of fry, continues profitable. Many statements have been received from fishermen as to the abundance of cod in the inshore waters and their presence on new grounds, especially on the southern part of Massachusetts. The following note is typical of a number of letters that might be quoted:

Possibly it will interest you to know that the "rock" cod, as we call them, caught along our shores within a mile or so of the coast and from the bold shore itself at times, have increased in number within the last two or three years. The present season they are remarkably abundant. Early in April (1897), when the herring were in, they could be caught with hand lines by the dory load, and just recently (May) have been caught from the rocky points along the shore, which has not been the case to any extent for twenty-five or thirty years before. They weigh from 2 to 10 pounds.

Reports from various localities along the coast of Massachusetts indicate that young lobsters are abundant, and if the work is continued on the same scale as in the past three or four years it is believed that this fishery will be fully reestablished.

A plan has been adopted to bring to the knowledge of those interested reliable and prompt statistics of the fisheries, by means of monthly bulletins showing the quantity and value of the catch landed at certain important ports, as well as special bulletins relating to the condition of the fishery industries. These reports are issued to those engaged in the business and to the various boards of trade. As this plan has received general commendation from those interested, it is designed to extend the system to embrace all centers of the fishing trade. At the end of each year these statistics will be issued in complete form, and comprehensive and reliable data will be at once available.

The field inquiries, described at length in the accompanying report of the Division of Statistics, covered an extensive territory, and attention may be called to some of the more important.

The canvass of the shad and alewife fisheries, which is of special interest on account of the fish-cultural operations with shad during recent years, has been very exhaustive, including statistics of the persons employed, appliances used, extent and value of the fisheries, and other special information. It was developed that in 1896 there were 27,000 persons engaged in these fisheries and a capital invested of about \$2,172,000. The catch amounted to 50,775,000 pounds of shad and 62,066,000 pounds of alewives, valued at \$1,656,000 and \$409,000, respectively.

The results of the canvass of the fisheries of the Pacific States are embodied in a special report published as an appendix to the report for 1896. The leading fishery product of this region is the chinook salmon, and the next most important is the oyster. In 1895 17,305 persons were engaged in the various branches of the industry and \$7,275,000 were invested. In some sections the fisheries are largely increased, San Diego and Los Angeles counties especially having built up considerable new trade with the interior States, though San Francisco continues to be the chief trade center for the reception and distribution of the products.

For the calendar year 1896 there has been a falling off in the quantities of fish landed by American fishing vessels at the ports of Boston and Gloucester, as compared with the prior year, the decrease affecting both ports. The aggregate receipts were 130,673,766 pounds, valued at \$3,286,898. Each species participated in the decrease, except halibut and mackerel, though at Boston the amount of cod landed was in excess of the previous years.

Inquiries during the summer of 1896 confirm the previous reports that the shad and striped bass introduced on the Pacific coast continue to increase, the former being so plentiful as to retail at very low prices. The striped bass are specially numerous in the San Francisco Bay region, and their rate of increase is such that at present their artificial propagation need not be considered.

The regular annual investigations of the fur-seal rookeries, under the direction of this office, were carried on during the summer of 1896 in

connection with the special commission appointed by the President in accordance with the joint resolution of Congress approved June 8, 1896, to investigate into the condition of the fur-seal herd. The Fish Commission representatives on the fur-seal commission were Lieut. Commander J. F. Moser, U. S. N., and Mr. C. H. Townsend.

During the summer of 1896, the steamer *Albatross* was engaged in Alaskan waters, having been detailed by the President to the Treasury Department for the use of the special commission. The vessel returned via Japan and Honolulu, arriving at Sausalito, Cal., December 11. On the 15th she was relieved from further duty in connection with the Treasury Department, and, after pressing repairs had been completed, sailed for San Diego December 30.

The recent very marked development of the fisheries off the coast of southern California makes it desirable that the extent, resources, and location of the principal fishing-banks be ascertained, and during the early part of the year 1897 the *Albatross* was engaged in provisional examinations of the fishing-grounds off the coast of Los Angeles County, Monterey, and in the vicinity of the Farallone Islands, to discover the possibilities of a further extension of the off-shore fisheries. For the first time in many years the vessel was available for exclusive fishery work, and accordingly preparations were made for a systematic study of the streams of southeast Alaska, to determine their resources and the abundance, movements, and habits of their fishes.

The active prosecution of the fisheries in certain streams threatens to seriously reduce the supply unless effective measures are taken to offset the destruction. The conditions are so different along the 3,000 miles of Alaskan coast that no general law is applicable to all parts of the Territory. The *Albatross* was prepared for this cruise at Sausalito, Cal., and on May 8 set sail for the Straits of Fuca. Observations and dredgings were made off Cape Flattery and in the Puget Sound region, and on May 29 the vessel, having been docked, started on a northern cruise. Inquiries were begun at Mary Island, southeast Alaska, and at the close of the fiscal year were being systematically carried on along the coast.

In accordance with the act of Congress approved December 22, 1896, the United States Fish Commission took part in the Tennessee Centennial Exposition, which opened at Nashville May 1, and is now in progress. Mr. W. de C. Ravenel was appointed representative on the board of management having charge of the Government exhibit. Fifteen thousand five hundred dollars and 5,000 square feet of space were allotted for the exhibit of the Fish Commission, which was arranged to show the character of the work performed by each of its divisions, the methods and apparatus employed, and the results attained. The material was collected and installed by the time of opening of the Government building May 17, 1897.

An aquarium 120 feet long, containing 22 tanks, has been provided, with an equal number of tanks for salt and fresh water, respectively, arranged in an ornamental manner on each side of a grotto. The

live-fish exhibit is intended to show the food-fishes propagated by the Commission, as well as a large number of important economic fishes of the Mississippi River Valley and the Southern States.

In the section of scientific inquiry are exhibited models of the vessels of the Commission, models and types of apparatus for collecting, assorting, and preserving specimens, and samples of the various appliances used in physical observations. The results of the scientific work are shown by means of charts, specimens of corals, starfish, sea-urchins, and various invertebrate animals, besides an extensive collection of oysters.

Models of pound nets, seines, spears, hooks, trawls, etc., illustrate the methods employed in the fisheries of the Southern States, and a series of models of fishing vessels shows their development from the crude craft first used in this country to the vessels now employed.

In the fish-cultural section hatching apparatus has been erected to illustrate practical fish-culture, and during the summer eggs of various species will be sent to the exposition and hatched.

In the office of the architect and engineer various maps, charts, and illustrations have been made, and plans and specifications prepared for the alterations and additions authorized, and repairs necessary at the different stations. Work at the new stations in Texas, Montana, and Iowa, which was in progress at the beginning of the year, has been completed.

At San Marcos, Tex., contracts were given out during the summer for the various constructions necessary to complete the station, and by the middle of November the office and workshop were finished. During the fall and early winter a concrete basin was built around the well, 4,000 feet of pathways were laid out, a roadway 3,000 feet long was built, the grounds were graded and fenced, and a number of suitable ornamental trees were set out. Ponds were excavated and the station was in condition for fish-cultural work in December.

At Bozeman, Mont., the work was completed with the funds made available by the appropriation of June, 1896, and the station turned over to the superintendent on the 1st of January, 1897. The station consists of a hatchery with a capacity of about 500,000 eggs, an eight-room cottage for the superintendent, an ice-house, a barn, and other outbuildings. Four stock ponds, eight rectangular ponds for rearing yearling fish, and twelve nursery ponds were at this time ready for use.

Work on the Manchester Station was promptly begun after July 1, and a hatchery, superintendent's dwelling, mess-house, barn, and other necessary buildings were erected, and an old farm-house on the site remodeled for foreman's quarters. Twelve small rearing-ponds were completed and eight large ones excavated; a wagon bridge was built across the Spring Branch, the hatchery connected with the water supply by a 14-inch pipe, and, though the large ponds were not lined, the station was in condition to begin active work in January.

An act of Congress approved June 8, 1896, provided for improvements at Northville Station, Michigan, and in accordance therewith arrange-

ments were made for building a new hatchery and superintendent's residence; by December 1 both buildings were completed. The hatchery is a two-story building, 69 feet long by 40 wide. The first floor is utilized for hatching operations and is equipped with the Clark-Williamson and also with ordinary gravel troughs. It has a capacity for about 12,000,000 eggs. The cottage is a two-story frame structure with a cellar and attic, 40 by 31 feet, and contains four rooms and a hall on the first floor and six rooms on the second. Improvements to the water supply were made so that the flow from one spring was increased from 180 to 438 gallons per minute, and as it appeared that the rotting timber in the old rearing-house was injuriously affecting the water from the other spring, the building was torn down, the ground graded, and a stone wall built around the spring. Another artesian well was also driven, which furnishes 50 gallons of clear, cold water per minute, which will be of value in regulating the temperature of the creek water used for the ponds. The cottage formerly used as a superintendent's residence was moved to a new location and remodeled for foreman's quarters.

For the new station in Tennessee, authorized by act of Congress approved August 8, 1894, after an examination of various localities throughout the State a site was selected at Erwin, Unicoi County, which appeared to combine all the important features necessary for a fish-cultural station, there being an ample supply of cold spring water, railroad connections, and facilities for collecting brood fish and eggs. The property was surveyed and, as soon as a title was obtained, was transferred to the Fish Commission. Plans and specifications for the buildings, ponds, and water supply were made and a railroad siding arranged for. A telephone line was constructed, and at the close of the fiscal year contracts for the construction of the hatchery and buildings had been let and some progress made in excavating for the water supply and ponds.

Early in the summer steps were taken to have the station at Wytheville, Va., formally turned over to the Commission by the State of Virginia, the necessary appropriation having been secured for this purpose. Upon an investigation by the Department of Justice, however, it was found that the act passed by the Virginia legislature on March 2, 1894, was defective, and an arrangement was accordingly entered into between the Commissioner and the board of public works of the Commonwealth of Virginia, by which the Commission assumed control of the property pending the completion of the title.

The act approved June 11, 1896, provided for the establishment of a station in the Black Hills of South Dakota, and accordingly in December, 1896, a careful examination of a number of available localities was made, and a site in the vicinity of Spearfish was found to be most suitable. An abundant supply of clear, cold spring water, with a sufficient fall for a gravity system for the hatchery and ponds, is available. The point is close to a railroad line and easy of access, and the topography of the land is such that the necessary constructions can be economically made.

A further examination will be made during the dry summer season, to determine if the water supply will be sufficient at all times of the year.

Further investigations with reference to the selection of a fish-cultural station in the State of New Hampshire, authorized by an act approved March 2, 1895, were made in December and January, and as soon as an examination during the dry season can be completed a site will be definitely selected and the construction of the station begun.

Necessary alterations and additions to the machinery of the Commission have been made under the direction of the naval engineer, who also prepared drawings and specifications for new boilers for the steamer *Fish Hawk*. This office also prepared plans for the pumps and other machinery for the exhibit of the Commission at the Nashville Exposition and superintended the installation of the plant.

During the year the bound Bulletin for 1896, the bound reports of the Commission for the years 1893, 1894, and 1895, and the report for 1896 in pamphlet form were issued, and, in addition, the following pamphlet extracts from the Reports for 1893, 1894, 1895, and 1896, and the Bulletin for 1896:

- Report of the Commissioner for the fiscal year ending June 30, 1894, including the reports on the divisions of fish-culture, scientific inquiry, and fisheries, by Marshall McDonald. Report for 1894, xx, pp. 1-175. 1896.
- The Russian fur-seal islands, by Leonard Stejneger. Bulletin for 1896, xvi, pp. 1-148, plates 1-66. 1896.
- Remarks on the movements and breeding-grounds of the fur-seal, based on observations made while on the United States naval patrol of Bering Sea in 1894, by John J. Brice. Report for 1894, xx, pp. 573-577.
- A report upon salmon investigations in the headwaters of the Columbia River, in the State of Idaho, in 1895; together with notes upon the fishes observed in that State in 1894 and 1895, by Barton W. Evermann. Bulletin for 1896, xvi, pp. 149-202, plates 67-72.
- The artificial propagation of the rainbow trout, by George A. Seagle. Bulletin for 1896, xvi, pp. 237-256, plates 88-94. 1896.
- The artificial propagation of salmon on the Pacific Coast of the United States, with notes on the natural history of the quinnat salmon, by Livingston Stone. Bulletin for 1896, xvi, pp. 203-235, plates 73-87.
- Report upon the operations of the U. S. Fish Commission steamer *Albatross* for the year ending June 30, 1894, by Z. L. Tanner and F. J. Drake. Report for 1894, xx, pp. 197-278, plates 6-8. 1896.
- Description of a closing tow net for submarine use at all depths, by C. H. Townsend. Report for 1894, xx, pp. 279-282, plates 9, 10. 1896.
- The whitefishes of North America, by Barton W. Evermann and Hugh M. Smith. Report for 1894, xx, pp. 283-324, plates 11-28. 1896.
- A report upon the fishes of the Missouri River Basin, by Barton W. Evermann and Ulysses O. Cox. Report for 1894, xx, pp. 325-429. 1896.
- A review of the foreign fishery trade of the United States, by Charles H. Stevenson. Report for 1894, xx, pp. 431-571. 1896.
- The ichthyological collections of the U. S. Fish Commission steamer *Albatross* during the years 1890 and 1891, by Charles H. Gilbert. Report for 1893, xix, pp. 393-476, plates 20-35. 1896.
- An annotated catalogue of the fishes known from the State of Vermont, by Barton W. Evermann and W. C. Kendall. Report for 1894, xx, pp. 579-604.
- A report upon the fishes of southwestern Minnesota, by Ulysses O. Cox. Report for 1894, xx, pp. 605-616. 1896.
- List of publications of the U. S. Commission of Fish and Fisheries from its establishment, in 1871, to February, 1896, by Charles W. Scudder. Report for 1894, xx, pp. 617-706. 1896.
- Deep-sea explorations: A general description of the steamer *Albatross*, her appliances and methods, by Z. L. Tanner. Bulletin for 1896, xvi, pp. 257-428, plates I-XI. 1897.
- Report of the Commissioner for the fiscal year ending June 30, 1895, including the reports on the divisions of fish-culture, scientific inquiry, and fisheries, by Marshall McDonald. Report for 1895, xxi, pp. 1-123. 1896.

- Report upon the investigations of the U. S. Fish Commission steamer *Albatross* for the year ending June 30, 1895 (abstract), by F. J. Drake. Report for 1895, XXI, pp. 125-168. 1896.
- Notes on Biscayne Bay, Florida, with reference to its adaptability as the site of a marine hatching and experiment station, by Hugh M. Smith. Report for 1895, XXI, pp. 169-191. 1896.
- The transplanting of eastern oysters to Willapa Bay, Washington, with notes on the native oyster industry, by C. H. Townsend. Report for 1895, XXI, pp. 193-202, plate 1. 1896.
- Description of a new species of shad (*Alosa alabama*) from Alabama, by Barton W. Evermann. Report for 1895, XXI, pp. 203-205. 1896.
- A check-list of the fishes and fish-like vertebrates of North and Middle America, by David Starr Jordan and Barton Warren Evermann. Report for 1895, XXI, pp. 207-584. 1896.
- Report of the Commissioner for the fiscal year ending June 30, 1896, including the reports of divisions of fish-culture, scientific inquiry, and fisheries, by John J. Brice. Report for 1896, XXII, pp. 1-145, plates 1-10. 1897.
- Report of the representative of the U. S. Fish Commission at the Cotton States and International Exposition at Atlanta, Ga., in 1895, by W. deC. Ravenel. Report for 1896, XXII, pp. 147-167, plates 11-21. 1897.
- Notes on the extension of the recorded range of certain fishes of the United States Coast, by Hugh M. Smith and William C. Kendall. Report for 1896, XXII, pp. 169-176. 1897.
- Notes on the food of four species of the cod family, by William C. Kendall. Report for 1896, XXII, pp. 177-186. 1897.
- The fisheries of Indian River, Florida, by John J. Brice et al. Report for 1896, XXII, pp. 223-262, plates 22-60. 1897.
- Report on the fish and fisheries of the coastal waters of Florida, by John J. Brice. Report for 1896, XXII, pp. 263-342. 1897.
- Report of a survey of the oyster regions of St. Vincent Sound, Apalachicola Bay, and St. George Sound, Florida, by Franklin Swift. Report for 1896, XXII, pp. 187-221. 1897.

There have been distributed 4,340 bound and 11,473 pamphlet copies of the publications of this Commission.

The United States National Museum has published the following reports, based on collections of fish made by the Fish Commission steamer *Albatross*:

- Report on the fishes dredged in deep water near the Hawaiian Islands, with descriptions and figures of twenty-three new species, by Charles Henry Gilbert and Frank Cramer. Proceedings of the U. S. National Museum, vol. XIX, pp. 403-435 (with plates XXXVI-XLVIII).
- Descriptions of twenty-two new species of fishes collected by the steamer *Albatross*, of the U. S. Fish Commission, by Charles Henry Gilbert. Proceedings of the U. S. National Museum, vol. XIX, pp. 437-457 (with plates XLIX-LV).

Appropriations were made by Congress for the operations of the Commission for the fiscal year ending June 30, 1896, as follows:

Salaries.....	\$182,060
Miscellaneous expenses:	
Administration.....	9,000
Propagation of food-fishes.....	115,000
Maintenance of vessels.....	30,500
Inquiry respecting food-fishes.....	10,800
Statistical inquiry.....	5,000

A report, showing in detail the expenditures of these appropriations, was submitted to Congress December 6, 1897.

J. J. BRICE,
U. S. Commissioner of Fish and Fisheries.

REPORT ON THE PROPAGATION AND DISTRIBUTION OF FOOD-FISHES.

By W. DEC. RAVENEL, *Assistant in Charge.*

INTRODUCTION.

The work of the Division of Fish-Culture, prosecuted on the same general lines as in past years, is shown by the following abstracts of reports of the superintendents of the various stations. The same stations were operated as in 1896, with the addition of those at Manchester, Iowa, and San Marcos, Tex., which were completed in December. The output of salmon fry was largely augmented by the establishment of auxiliary stations at Battle Creek, Cal., on Salmon River, Oregon, and the Little White Salmon, Washington, which were operated in conjunction with Baird and Clackamas stations. During the year all the stations in New England and on the Great Lakes, as well as those at Wytheville and Quincy, were inspected by the Commissioner and the assistant in charge of the Division of Fish-Culture.

The shad work on the Atlantic Coast was also largely increased, and steps were taken to investigate the rivers along the South Atlantic coast with the view to the establishment of auxiliary stations. On the New England coast, in addition to the operations conducted at Woods Hole and Gloucester, the *Grampus* and *Fish Hawk* were utilized during May and June in collecting lobster eggs off the coast of Maine. The crew of the *Grampus* also rendered material assistance in the cod work, collecting eggs for Gloucester Station from fishing vessels at Kittery.

From the experience gained the past season it is believed that a cod-collecting station can be advantageously established at Plymouth, Mass., and if successful it will obviate the necessity of penning brood fish at Woods Hole, materially reducing the expense of that station.

During the fiscal year 586,144,000 fish and eggs, embracing 30 species and 1 crustacean, were distributed from the following stations:

Green Lake Station, Me.	Put-in Bay Station, Ohio.
Craig Brook Station, Me.	Northville Station, Mich.
St. Johnsbury Station, Vt.	Alpena Station, Mich.
Cape Vincent Station, N. Y.	Duluth Station, Minn.
Gloucester Station, Mass.	Manchester Station, Iowa.
Woods Hole Station, Mass.	Quincy Station, Ill.
Steamer <i>Fish Hawk</i> (Albemarle Sound, Delaware River, and Casco Bay).	Neosho Station, Mo.
Battery Island Station, Md.	San Marcos Station, Tex.
Bryan Point Station, Md.	Leadville Station, Colo.
Central Station, Washington, D. C.	Bozeman Station, Mont.
Fish Commission lakes, Washington, D. C.	Baird Station Cal.
Wytheville Station, Va.	Battle Creek Station, Cal.
	Fort Gaston Station, Cal.
	Clackamas Station, Oreg.

A comparison of this season's work with that of the previous year shows a gratifying increase in the output of fry of most of the important commercial species propagated, such as shad, salmon, lake trout, lake herring, cod, quinnat salmon, Atlantic salmon, flatfish, and lobsters. The distribution from the various stations was made as in past years by station employees in neighboring waters and by means of the four cars owned by the Commission. Owing to the increased output of the various species it became necessary during the spring to hire an additional baggage car from the Pennsylvania Railroad Company to assist in the distribution of shad.

The total mileage traveled by the cars and messengers while engaged in the distribution amounted to 206,615 miles, 84,892 of which were free. The only accident which occurred during the season was at San Francisco, where a freight train collided with car No. 3. The car was repaired free of expense to the Commission by the Southern Pacific Railroad Company.

Car No. 3 was utilized as a temporary hatchery on the St. Johns River, Florida, during February, March, and April. At the opening of the Nashville Exposition in May car No. 4 was detailed for the collection and transfer of marine specimens for the exposition.

Many changes occurred in the personnel of the messenger service during the year, the most important being the promotion of Capts. R. S. Johnson and G. H. Lambson to the superintendency of the stations at Manchester, Iowa, and Baird, Cal., respectively.

GREEN LAKE STATION, MAINE (E. E. RACE, SUPERINTENDENT).

The stock of fish on hand having been distributed during the month of June, the time of the station force during the summer was devoted to the improvement of the water supply, construction of ponds, and general repairs and improvements to the buildings and grounds. The main flume from Rocky Pond to the reservoir, 6,800 feet long, was thoroughly overhauled and arrangements were made to run the water from the flume direct to the hatchery instead of accumulating it in the reservoir as heretofore.

The old ponds between the hatchery and reservoir were condemned and partly refilled, the two back of the hatchery were rebuilt, and five new ones were constructed. The old ponds were 20 feet wide by 38½ feet long, the new ones 16½ feet by 38½ feet. A 2-inch pipe was laid from the hatchery to a spring on the side of the mountain, furnishing an increase of 25 gallons of water per minute during the dry season, at a temperature of 43°. During the spring months the amount obtained from this source is much larger.

The usual arrangements were made for collecting eggs from wild fish in Green Lake, Manns Brook, Great Brook, Winkempaugh Brook, Patton Pond, and Boggy Brook. The first landlocked salmon was captured September 17 at Manns Brook and the first brook trout September 29. The run of golden trout at Floods Pond commenced November 1

and continued until November 16. The fish taken were held in traps in Great Brook, Floods Pond, and Patton Pond until their eggs had matured. The brook trout commenced spawning October 17, the salmon on October 19, and the golden trout November 3. The last eggs secured from the salmon were on November 17 and from the golden trout on November 28. The following table shows the number of brook trout, landlocked salmon, and golden trout taken in the various traps and the number of eggs obtained from them:

Body of water.	Landlocked salmon.		Brook trout.		Golden trout.	
	Fish.	Eggs.	Fish.	Eggs.	Fish.	Eggs.
Green Lake.....	190	217,760	12	16,500
Wirkempangh Brook.....	49	91,500	211	147,202
Floods Pond.....	4	10,000	37	8,000	90	82,000
Patton Pond.....	4	5,200	110	114,000
Total.....	247.	324,466	370	285,702	90	82,000

In accordance with the usual custom, at the close of the season the adult fish were returned to the waters from which they were taken. A number of ripe female salmon collected at Floods Pond yielded 12,000 eggs, but as no males were captured an effort was made to fertilize them with milt forwarded from the Green Lake hatchery in an air-tight jar, which was held for thirty-six hours after its receipt. Fertilization was apparently accomplished and the eggs were forwarded to the hatchery, but after remaining in the troughs for some time they all turned white and were thrown away.

During the fall the following shipments of eggs were made from the station: Of the landlocked salmon, 82,000; quinnat salmon, 30,000; brook trout, 40,000; golden trout, 10,000.

The following consignments were received: From Battle Creek, Cal., 1,000,000 quinnat-salmon eggs; from Fort Gaston, Cal., 50,000 steelhead-trout eggs, and from Craig Brook, Me., 50,000 Atlantic salmon eggs.

The quinnat-salmon eggs arrived in excellent condition on December 17, and commenced hatching February 22. They finished by April 10, the total loss, including the number found dead on arrival, amounting to 75,500. The fry resulting from them were held until the absorption of the sac and then planted in the tributaries of Union River. The steelhead eggs arrived in very bad condition, and had finished hatching by May 18. Only 9,335 young fish remained on hand at the close of the year as a result of this shipment. The Atlantic-salmon eggs commenced hatching on March 20, and after a distribution of 33,000 of the fry during the month of June there still remained 16,220 at the close of the year. These were placed in the reservoir to be reared for brood stock. By April 25 all of the landlocked-salmon, brook-trout, and golden-trout eggs had hatched, the losses during incubation being comparatively small. A sudden rise in temperature during the month of June necessitated a partial distribution of the stock, and at the close

of the year there remained on hand 131,141 landlocked salmon, 16,220 Atlantic salmon, and 9,335 steelhead trout.

Having decided to discontinue the distribution of Von Behr trout, the 769 brood fish on hand in the fall were turned over to the fish commissions of Maine and Vermont. While the flume was being prepared during the summer it was found impracticable to provide ponds for the landlocked salmon that had been reared at the station, and, in view of the fact that they were about 6 years old and had never produced healthy eggs, it was determined to liberate them in Green Lake. There were 2,164 of these fish, varying from 1 to 3 pounds when liberated.

CRAIG BROOK STATION, MAINE (CHARLES G. ATKINS, SUPERINTENDENT).

During the year two large, deep ponds were constructed on the flat alongside Alamoosook Lake for the purpose of continuing the experiment of rearing Atlantic salmon under domestication and for domesticating such species as the steelhead trout, landlocked salmon, and quinnat salmon. These ponds are each about 3,750 feet in area, and the expense of building them was \$679. In addition to a number of minor improvements to the buildings and grounds, the old wagon-house was moved and repaired, a stone bridge was built across the brook, two gravel breakwaters were constructed to protect the boat-landing, the fly-house was transformed into a hatchery for the purpose of caring for the quinnat-salmon eggs transferred from the Pacific Coast, and a new stand of troughs was erected for holding the fry. An aqueduct 700 feet long was also constructed in order to convey the water supply from Craig Brook to the above-mentioned stands and hatchery.

At the beginning of the year there were on hand the following fry, hatched the previous spring:

Atlantic salmon	244,405	Swiss lake trout.....	46,796
Landlocked salmon	11,033	Von Behr trout.....	487
Quinnat salmon	7,796	Scotch sea trout.....	1,337
Brook trout.....	2,668	Steelhead trout	12,511
Rainbow trout	12,778		
American lake trout.....	38,965	Total	378,776

During July 3,315 steelheads were liberated; the remainder of the stock was carried through to October, when the fish were counted and distributed with comparatively small losses. The food given was the same material usually employed—chopped liver and other butchers' offal, the flesh of horses, and maggots reared at the station. A small quantity of herring roe was also used and appeared to be acceptable to the quinnats, though it was not readily taken by the Atlantic salmon. As in former years the food most readily eaten was the maggots, which were given alive. This year for the first time a large number of fry were kept in the ponds, and although the losses were slightly heavier than heretofore, these fry did remarkably well and outgrew the trough fish. In all, 102,265 Atlantic salmon and 8,122 steelhead trout were transferred to the ponds; three months later 91,017 Atlantic salmon and 7,398 steelheads were removed, showing a loss of 11 per cent on the

XXII REPORT OF COMMISSIONER OF FISH AND FISHERIES.

salmon and 8.9 per cent on the steelheads. The loss in the troughs amounted to 9.1 per cent, 143,374 salmon being taken out at the expiration of seven months. It is probable that the loss on the trough fish during the three months that the others were in the ponds did not exceed 3 per cent, but in point of growth the pond fish were far superior, the pond salmon in the fall averaging 101.1 grains against a mean of 45.8 for the trough fish. These figures were obtained by actually weighing the fish.

A summary of the result of rearing fry to the yearling stage from eggs collected in the fall of 1895 is presented below in tabular form:

Kind.	Number of eggs.	Number hatched.	On hand June 1, 1896.	On hand July 1, 1896.	Total remaining at fall count.	Percentage—		
						Of eggs laid out.	Of fish hatched.	Of fish remaining alive June 1.
Atlantic salmon.....	275,004	274,158	263,818	244,405	234,983	85.4	85.7	89.1
Quinnat salmon.....	8,345	8,248	7,061	7,796	7,407	88.7	89.7	95
Landlocked salmon....	18,883	18,730	12,464	11,033	10,889	57.7	58.1	87.3
Brook trout.....	7,120	6,304	2,726	2,668	2,219	31.2	34.8	81.4
Rainbow trout.....	25,485	25,377	13,303	12,778	11,651	45.7	45.9	87.6
Swiss lake trout.....	51,892	51,294	49,803	46,796	41,130	79.3	80.2	82.0
Von Behr trout.....	7,371	6,652	5,978	487	653	8.8	9.8	10.9
Lake trout.....	43,460	42,906	40,112	38,065	10,411	23.9	24.3	25.9
	437,560	433,735	396,165	364,928	319,343	72.9	73.6	80.6

Atlantic salmon.—During the previous June 677 brood salmon were collected and released in the inclosure at Dead Brook; and, with the view of increasing this stock, a trap was constructed early in August near the Bangor Dam in order to stop any salmon that might ascend the river to spawn in the fall. This dam, located below the natural head of tide water, is subject to partial submergence during periods of high water. It is also provided with a good fishway, but it forms a serious obstacle, nevertheless, to the ascent of fish, and considerable numbers were collected there during the season. They were especially noticed under the wheelhouse of the waterworks at the west end of the dam, where the trap was located. This trap was constructed of steel and wood, as offering the least resistance to the constant heavy current, being formed like a pound in an ordinary weir, with a V-shaped entrance and a wing running obliquely out into the river. It was secured by bolts and numerous guys in the ledge forming the bed of the river, and was provided with halyards by which it could be drawn up for inspection or hauled down for work. The trap proved to be well adapted for the purpose, as the salmon passed in readily and were removed without difficulty or serious injury. The work of construction was quite arduous and consumed more time than was anticipated, as it was not ready for operation until August 12, when the water temperature registered 79°. It had also become very muddy from the operations of a contractor who was putting in a cofferdam preliminary to some improvements to the waterworks. Under these adverse circumstances very few salmon were taken; but the conditions improved later on, and 8 were secured

on August 27, making a total of 33 captured by the trap. These were placed in the cars and towed to Orland, whence they were transferred to the Dead Brook inclosure, 26 of them being delivered alive.

It appears that salmon do not congregate in large numbers at mid-summer, and, moreover, it is very difficult to transfer them at that season to the inclosure, which is 30 miles distant, on account of the high temperature of the water. To obtain good results, the trap should be constructed early in the spring and a retaining pool provided in the immediate vicinity.

During the summer 109 dead fish were removed from the pools, which should have left 594 breeders, but as a matter of fact only 539 were found, indicating a loss of 25 per cent. Of these, 174 were males and 365 females, 12 of which yielded no eggs. From the others, the weight of which aggregated 1,050 pounds, 3,192,124 eggs were secured, of which the Maine Commission received 496,000. From the remainder, 490,000 were shipped as follows: To the New York Fish Commission, 100,000; to the Connecticut Fish Commission, 100,000; to U. S. Fish Commission stations, 100,000; to W. S. Hadaway, Plymouth, Mass., 25,000; to the Pennsylvania Fish Commission, 100,000; to the Adirondack League Club, 25,000; to Amos Ellis, Rangeley, Me., 40,000.

From the balance of the eggs 2,008,766 fry were hatched, all of which, with the exception of 390,000, were liberated in the tributaries of the Penobscot above Oldtown and in streams in the vicinity of the station; 150,000 were planted in the St. Croix River at Vanceboro, and 240,000 were retained for rearing. The loss on this stock to the close of the year amounted to 24,442. At the beginning of the year there were on hand 705 Atlantic salmon which had been hatched during the season of 1893-94; of these, 290 were distributed and the balance were placed in one of the new ponds and retained for domestication. In June, 1897, the usual arrangements were made for the collection of adult salmon, but owing to the late run only 595 were obtained. The losses during June were very light, and favorable results are expected in the fall.

From the two lots of domesticated salmon (descendants of parents reared in confinement in fresh water) 4,400 eggs of inferior quality were secured during November; these yielded 2,167 fry, but only 1,600 of them survived to the close of the year. Of the parent fish there now remain 41.

Landlocked salmon.—Late in October 10,889 yearling landlocked salmon were deposited in Toddy Pond. These fish resulted from a consignment of eggs delivered at the station by a number of citizens who were interested in keeping up the supply of fish in that pond. In November, 1896, the same parties furnished another consignment of 2,352, from which 2,129 fry were hatched.

Other species.—The brook, rainbow, lake, and von Behr trout were distributed with the other fishes in the fall, the losses being very slight, except in the case of the lake trout. On July 1 there were 38,965 lake trout on hand, as a result of the eggs shipped from North-

ville the previous winter. They appeared to be very healthy for a time, but later in the summer they were attacked by a parasitic trematode, which appeared in large numbers, especially on their fins and jaws. The mortality resulting aggregated over 26,000, leaving only 10,411 for distribution in November. No other species were attacked by this parasite, though all were kept in the same locality and under the same conditions. A large percentage of fish was hatched from the consignment of Swiss lake-trout eggs received from Switzerland in February, 1896. A few of these were held over and distributed in the spring of 1897, but the bulk of them were disposed of in the fall.

Steelhead trout.—The fish on hand at the beginning of the year were carried through the summer with small loss, and all of them with the exception of 200 were distributed during the fall. These were placed in one of the new ponds for domestication, and 191 of them survived to the close of the year. From a consignment of eggs received in April 94,811 fry were hatched; all but 10,000 of these, which have been retained for rearing, were distributed in local waters during May and June.

Quinnat salmon.—The quinnat salmon on hand at the beginning of the year were the result of a consignment of eggs received from Baird in December, 1895. They were carried through the summer without material loss, and in November 7,062 yearlings were liberated in local waters. During the fall 200 of them were transferred to the aquarium in Washington and held until the following spring, when they were sent to Nashville for exposition purposes. Another lot of 200 was retained at the station until the following June, when they were liberated, with a loss of only 4, in local waters. In December, 1896, a consignment of 1,440,000 eggs was received from Battle Creek, Cal. Some slight mishaps befell them and it became necessary to crowd them considerably on account of lack of space, but notwithstanding these adverse circumstances 1,255,594, or 87 per cent, of them hatched. Of these, 789,000 were deposited in the Penobscot and its branches above Oldtown, 77,449 were liberated in local waters, and 50,000 were transferred to the Maine Commission, making a total distribution of 916,449; 250,000 were reserved at the station to be reared and distributed in the fall, and at the close of the year they were in excellent condition.

The total amount of food used consisted of 42,746 pounds of butcher's offal, beef blood, and horse carcasses, the original cost of which was \$592.25, the additional expense of freight and drayage aggregating \$105.97. This large increase in cost and amount of food was due to the increased number of fish carried; and it was learned by experiment that quinnat salmon require a larger amount of food than Atlantic salmon and other fishes.

The stock of fry held for distribution in the fall consisted of 240,000 Atlantic salmon, 2,167 domesticated Atlantic salmon, 2,295 landlocked salmon, 250,000 quinnat salmon, 1,894 Scotch sea trout, and 10,000 steelhead trout.

Following is a record of the meteorological observations made at the station during the year:

Date.	Mean temperatures.						Rain-fall. Inches.	Snow. Inches.
	Air.		Water.					
			Hatchery. inside.		Head of feed- trough stand.			
	7 a. m.	2 p. m.	7 a. m.	2 p. m.	7 a. m.	2 p. m.		
1896—July	64.71	70.00	68.98	71.77	63.55	67.35	5.05
August	61.02	74.56	69.28	72.23	64.05	68.40	1.55
September	53.45	64.88	62.78	65.05	59.83	63.13	6.95
October	40.27	51.74	53.08	55.15	52.18	55.00	4.15
November	34.02	40.73	44.73	46.15	45.70	47.37	4.25
December	17.77	27.85	34.74	35.45	37.92	39.29	1.55
1897—January	13.81	26.02	33.56	34.19	36.65	38.18	1.65	18
February	15.09	30.62	33.06	34.82	35.34	38.02	1.65	9
March	24.55	35.13	34.11	35.77	35.87	38.87	2.30	14½
April	37.13	50.10	37.95	40.98	38.72	43.42	2.35
May	49.14	60.49	50.77	53.06	48.70	52.37	3.90
June	55.54	65.77	58.71	60.92	54.60	57.82	3.00

ST. JOHNSBURY STATION, VERMONT (J. W. TITCOMB, SUPERINTENDENT).

A special appropriation for increase of the spring water supply, construction of reservoir, and general improvement to the grounds having been provided, the work was undertaken early in the summer under the direction of the superintendent. In order to increase the water supply, the springs on the station property were developed by excavating ditches into the hillsides. These were lined with 3-inch land tile, laid on hemlock boards and covered with stones and gravel. Wooden boxes were set at the outlet of each ditch to catch the water, from which it is conveyed through pipes connecting with the main line to the reservoir. Much difficulty was experienced in making the excavations on account of the land containing quicksand and clay, which also made it impossible to obtain water free from sediment. The supply secured by this means was about double the amount obtained under the old system. During the rainy season the capacity of the springs has averaged about 80 gallons per minute.

In order to prevent the clogging of the intake at the dam in Sleepers River, a deflecting wall 30 feet long, 6 feet wide at base, 4 feet wide at top, and 6 feet high, was constructed. A framework of timber inserted in the wall on the east side near the lower end and fastened to the intake on the west side forms a recess for the water to pass through into the intake. This recess is protected by a grating formed of iron rods extending perpendicularly down through the framework. Below the grating, between the jetty and the crib, a piece of 10-inch cast-iron pipe was inserted, to be used for flushing during periods of high water, when the entrance to the crib becomes filled with sediment. The wooden gates connecting the two 8-inch pipe lines were replaced by iron ones.

A reservoir of 172,198 gallons capacity was constructed between Emerson Falls and the hatchery, at an elevation of 83 feet. A much

XXVI REPORT OF COMMISSIONER OF FISH AND FISHERIES.

larger one had at first been proposed, but it became necessary to reduce the size owing to the discovery of quicksand. The reservoir was surrounded by a wall made of local stone and Rosendale cement, the dimensions being 2½ feet thick at base, 2 feet at top, and 5 feet in height. The sides of the reservoir and the wall were covered with Portland cement and plastered with a mixture of 1 part cement to 2½ parts clear sand. The filter to the reservoir is so constructed that it can be cleaned by reversing the current. A roof was constructed over the reservoir, four doors being provided in it to permit access to the reservoir. On January 23 the overflow from the reservoir was broken by an earthquake, which interfered materially with its use until the weather permitted of its being repaired.

Considerable work was done in grading the grounds, building plank walks around the ponds, installing a steam-heating plant, and in repairing the ponds constructed the previous year, frost having injured them to such an extent that it became necessary to rebuild all of the supply and stand pipes. A large amount of work was also done in the interior of the hatchery, completing unfinished rooms, etc.

At the beginning of the year the stock on hand was as follows:

Species.	Calendar year in which hatched.	
	1896.	1895.
Brook trout.....	8,748
Rainbow trout.....	700
Atlantic salmon.....	1,753
Steelhead trout.....		90
Lake trout.....		5
Total.....	11,201	95

During the summer field stations for collecting brook-trout eggs from wild fish were established at Darlings Pond, Caspian Lake, Greensboro, Willoughby Lake, Groton, Fairbanks Pond, and Pico Pond.

Darlings Pond is about 36 miles from St. Johnsbury, 30 by rail and 6 by wagon road. The fish there were captured by means of a V-shaped slat trap or weir and held in retaining pens until ripe. A shanty was erected near the trap for the accommodation of the attendant. The first run of trout occurred on the 23d of August, 1,650 being taken in the brook during a heavy rain storm. Very few were captured from that time until September 6, when 1,000 more entered the trap. The fish continued to run in schools during the rainy weather, and on October 15, when the trap was removed, 7,138 had been captured. During the season it was discovered that large numbers of trout were ascending streams which dry up in summer. At the request of the owners of the pond they were not disturbed, but it is doubtful whether their spawn ever matured. The first eggs were taken on September 24 and the last on October 26, over 900,000 being secured. The loss in hatching was very heavy, only 25 per cent producing fry available for distribution; but these were vigorous, and no definite reason can be

ascribed for the large loss, though it has been attributed to confinement of the trout for a considerable period before they were ripe. Next year a temporary auxiliary hatchery will be constructed at this point.

At Caspian Lake, 32 miles from St. Johnsbury, the trout were collected by means of small-meshed gill nets and dip nets, the only improvement in the apparatus being the jack lights, which were constructed especially for the purpose. Most of the fish were caught between sunset and midnight. The first were captured October 29, and work continued until the lake froze over, on December 2. Long after the 1st of January the trout could be seen at work on their beds under the ice. The total number taken in dip nets amounted to 1,457, their average weight being a little over 1 pound. The season lasted one month, commencing November 10, and 97 per cent of the 500,000 eggs were good. For convenience and comfort while collecting the eggs a boat-house was constructed over the confining pen in the lake, with platform space for the spawn-takers. The eggs were placed in a small private hatchery located near the lake, and as soon as they had reached the eyed stage were transferred to St. Johnsbury. The hatching of the eggs taken at this point continued from January 17 to about the end of April.

Willoughby Lake (situated 26 miles from the station, 16 by rail and 10 by wagon road) was examined with the view to collecting eggs of the lake trout, but owing to pressure of other work the investigation was delayed until November 10, when it appeared that the fish had already deposited their eggs. From the extent of the spawning-grounds and the abundance of fish there seems to be little doubt that a large number might have been taken. Suitable facilities were found for the establishment of an auxiliary field station.

At Fairbanks Pond, 3 miles from St. Johnsbury, 31,500 eggs were collected. The work at Pico Pond proved unprofitable, and operations were discontinued after 12,000 eggs had been secured.

All of the fish were returned to the waters from which they were taken, the total loss on nearly 10,000 amounting to only 36. During the winter 140,000 eggs were shipped to the applicants mentioned below, and from the balance of the season's take 491,000 fry were hatched, a fair proportion of which were returned to the waters from which the eggs were collected:

S. M. Pearson, Stratham, N. H....	10,000	L. J. Johnson, Brattleboro, Vt...	15,000
Vermont Fish Commission	50,000	Clarence Brown, Toledo, Ohio...	15,000
Adirondack League Club, N. Y....	25,000	Connecticut Fish Commission ...	25,000

While there is a marked difference in the sizes of the trout eggs taken from different waters, they do not always vary according to the size of the fish, as was supposed. The sizes of eggs taken at three of the field stations were in the proportion of 34, 41, and 42 to the square inch. Those numbering 34 and 42 to the inch were taken from trout averaging 5 to the pound, while those numbering 41 were secured from fish weighing over a pound each.

Observations as to the effect of low temperature on trout eggs confirmed the experience of the previous season. Eggs eyed and hatched entirely in the spring water (ranging from 45° to 50°) yielded a larger percentage and better fish than those taken under the same conditions and at the same time which were hatched in water varying from 32° to 50° in temperature. The comparisons were made with eggs collected at Caspian Lake. It was also observed that eggs eyed in spring water before being subjected to colder water yielded a larger percentage than green eggs laid down in cold water. The investigations were carried still further by trying different temperatures during the period of incubation on various lots of eyed eggs, but these were not fully completed owing to an accident to the water supply during the critical period.

It was intended to carry all of the eggs after they were eyed in a mixture of the spring and river water, the spring-water supply being insufficient, but on the 4th of March, and periodically from that time to April 15, it became necessary to shut off the spring water entirely. The eggs were thus subjected to the reduced water temperature from 12 hours to 16 days at a time, the temperature during these periods ranging from $32\frac{1}{2}^{\circ}$ to 35° . After reaching $32\frac{1}{2}^{\circ}$ the development of the eggs was apparently suspended for several days, which accounts for the length of time between the commencement and the end of the hatching periods with the various lots. One lot of 35,000 was placed in water registering $32\frac{1}{2}^{\circ}$ as soon as eyed and kept there until they hatched, for the purpose of comparing the results with those obtained in hatching in spring and river water mixed. They commenced hatching March 15 and finished April 24, the total loss to May 30 amounting to 520 eggs and 1,435 fry. An equal number of the same lot of eggs placed in mixed water, but subjected to changes caused by shutting off the spring water periodically, began hatching February 26 and finished April 15, with a loss of 1,223 fry and 487 eggs to May 30. Better results would undoubtedly have been secured had it not been necessary to shut off the spring water.

In addition to the collections made in the vicinity of the station 300,000 quinnat-salmon eggs were received in December from Battle Creek, 5,000 landlocked-salmon eggs from Green Lake in February, and 100,000 steelhead-trout eggs from Fort Gaston in April. The quinnat-salmon eggs arrived in excellent condition and commenced hatching on April 3 in water of an average temperature of 34° , but during the hatching period it went down to $32\frac{1}{2}^{\circ}$ on several occasions. The fry resulting from them numbered 200,000 at the time of their distribution. They were deposited in tributaries of the Connecticut and Merrimack rivers during the month of July. During incubation whitespots appeared on some of the embryos, causing the loss of many. Those on which the spots were most noticeable were separated from the others and in a large number of instances they hatched, the spots disappearing with the absorption of the sac. The steelhead-trout eggs arrived during a period of unusually warm weather and were in very bad condition,

only 26,379 healthy fry resulting from them; 10,000 were distributed in New Hampshire waters and the balance were retained for rearing.

During the summer months observations were made in air and water temperatures at Caspian Lake, with the view to testing the qualifications of the lake water for use in operating a trout hatchery on a large scale. During November the surface temperature ranged from 45° to 33°. On the spawning-beds (from 1 to 6 feet in depth) it registered the same, whereas it varied from 45° to 38° when taken from a depth of 40 feet. In December and January, with an air temperature below zero, the water from 20 to 100 feet registered 37° and 38° above zero, indicating that an equable temperature of from 37° to 40° can be maintained throughout the year with water taken at a depth of over 20 feet.

A small sandpiper was killed on June 13 and in its gizzard were found the vertebral columns of several small fish about 1½ inches long.

In November the superintendent was instructed to make an investigation in New Hampshire respecting the advisability of establishing a station for the propagation of trout at some suitable point in that State. This work covered a period of two weeks in December and January.

CAPE VINCENT STATION, NEW YORK (H. D. DEAN, SUPERINTENDENT).

An appropriation of \$2,500 having been secured for the completion of the hatchery and grounds, the work of improvement was commenced early in July. The building was completed, the grounds graded, a wire fence constructed around the property, a walk laid from the street to the hatchery, and a gas plant installed.

Permission having been granted by the Canadian Government to collect whitefish eggs in Bay Quinte, under the supervision of the fishery overseers, the grounds between Belleville and Deseronto were examined and arrangements were made with the fishermen to operate four seines in the vicinity of Massassaga Point, the fishermen agreeing to pay all expenses of running the seines for the coarse fish and to allow the Commission to have the whitefish. The fish were penned in crates, under the supervision of one of the employees of the station. Of the 400 collected, only 25 per cent proved to be females, and a number of these were so bruised in handling that the eggs were worthless. As it was seen that very few eggs could be taken at this point, on November 13 four more seines were secured nearer Deseronto. Many fish were caught there, but only a few were females, and these yielded no eggs, though they were held in pounds for some time. Pound nets belonging to the Commission were also operated in Chaumont Bay without results, and at Three Mile Bay six or seven traps were operated and a good many fish captured, but owing to heavy gales the bulk of them died before the eggs could be taken.

As a result of the season's operations only 2,300,000 eggs of very poor quality were obtained from all sources, from which 750,000 fry were hatched and liberated in the St. Lawrence River. The total cost of the work with this species for the season was \$476.41.

XXX REPORT OF COMMISSIONER OF FISH AND FISHERIES.

As there seemed to be little prospect of securing a supply of lake trout eggs in the vicinity of the station, early in November arrangements were made to attend the tug fishermen at Dunkirk, and as a result nearly 1,000,000 eggs were secured, at an expense of \$141. In addition to these 145,000 were taken in the vicinity of Charity Shoals, and on November 24 a consignment of 1,000,000 was received from Northville Station, giving a total of 2,085,000. The hatching period extended from April 19 to May 8, and the 1,290,000 fry hatched were distributed in Lake Ontario and its tributaries.

In addition to the operations with lake trout and whitefish the following consignments of eggs from other stations were hatched and distributed. A shipment of 2,095,000 quinnat-salmon eggs arrived from Baird, Cal., on December 15 in excellent condition, and although much crowded in the troughs, 94 per cent of them were hatched and were planted in tributaries of Lake Ontario and in the Hudson and Delaware rivers. One thousand of these fry were retained at the station, and at the close of the year they had attained a length of over 3 inches. From the 50,000 Atlantic salmon eggs received from Craig Brook 48,000 fry were hatched, the period of incubation extending from March 19 to April 8. All of the fry were deposited in the Salmon River on May 17. Two consignments of steelhead eggs, aggregating 50,000, were received from Fort Gaston on April 24. As they were in very bad condition on arrival, only 10,600 fry were obtained from them for distribution. A shipment of 27,700 rainbow-trout eggs from Wytheville yielded 11,600 fry, which were distributed soon after hatching to applicants in the State of New York.

The following table gives the average, maximum, and mean temperatures of air and water at the station for the fiscal year, by months:

1896.	Air.			Water.			1897.	Air.			Water.		
	Min.	Max.	Mean.	Min.	Max.	Mean.		Min.	Max.	Mean.	Min.	Max.	Mean.
July	62	85	73.5	61	72	66.75	January ...	-9	57	24	33	36	33.6
August	56	88	74	68	76	72	February ...	0	44	25.75	33	33	33
September	39	80	62	58	69	64.33	March	6	49	33.66	33	33	33
October	34	68	47	47	59	52	April	23	69	47	34.5	43.5	38
November	25	63	43.66	42	51	45.3	May	44	77	57	42	51.5	47.5
December	-1	48	27.4	33	41	36.8	June	49	85	66.75	50	64	59

GLOUCESTER STATION, MASSACHUSETTS (C. G. CORLISS IN CHARGE).

Upon the appointment of E. F. Locke as superintendent at Woods Hole in October, C. G. Corliss, fish-culturist, was placed in charge of Gloucester Station. Repairs were made to the hatching-boxes, buildings, and machinery, and by November 13 the station was ready for operations.

Cod.—The crew of the *Grampus*, under the direction of Captain Hahn, was stationed at Kittery Point, Me., as heretofore, and commenced making egg collections for the station on November 19. The eggs were transferred to Gloucester, packed in closed jars, and surrounded with

crushed ice or snow to keep the temperature equable. Collections continued daily until March 26, the total take amounting to 113,000,000 eggs, from which 62,305,000 fry were hatched and planted. The meteorological conditions during the season were much more favorable than for several years previous, especially in the months of November and December, when 63,000,000 eggs were secured, from which 45,000,000 fry were hatched. The fish from which the eggs were taken were caught in gill nets and in trawls fished by vessels making their headquarters at Kittery.

It has been customary to fertilize cod eggs by what is known as the wet method, but this year the dry method was employed, and the increased percentage of fry hatched is thought to have been due to that fact. This percentage, though much smaller than is secured with the eggs of other species handled by the Commission, was remarkably good considering the conditions under which they were taken. Owing to heavy storms it is frequently necessary to allow the fish to remain in the nets for several days, and in such instances those captured in the gill nets perish. The fish taken by the trawl nets frequently live for several days, and for this reason the eggs secured from that source are superior to those obtained from the gill nets. Where the fish have been dead only a short time it is customary to save the eggs, and though they appear to be good when received at the station very heavy losses occur after they have been in the apparatus for some time. The principal losses with cod eggs occur during the earlier stages of development, and until the embryo is well formed great care must be taken in handling them; after that stage has been passed they are quite hardy and comparatively few are lost. During the early part of the season the temperature ranged from 47° to 40°, but after the 15th of December it fell gradually, reaching 35° on January 15. It having been found that the water on the spawning-grounds ranges from 37° to 38°, steam was employed from that time on for the purpose of maintaining about the same temperature in the boxes.

The experiment of hatching eggs by means of air circulation in the McDonald automatic jar was again tried, but the results did not indicate that this method could be successfully adopted. The temperature of the water in the jars was kept at 40° by packing them in salt and ice; the water was changed twice a day during the earlier stages and more frequently later on, as it became foul in a very short time. About one-third of the eggs which reached the hatching point were hatched in the jars; the remainder, though kept in circulation for several days, did not hatch until they were transferred to a McDonald tidal box, when the fry appeared within twenty-four hours, being strong and healthy, apparently. Instead of liberating them in Gloucester Harbor, as heretofore, they were taken out in a sailing boat to the natural spawning-grounds in Ipswich Bay and deposited at the point of collection. The loss in transportation was very small.

XXXII REPORT OF COMMISSIONER OF FISH AND FISHERIES.

The following table shows the daily collections of cod eggs lost during incubation, number of fry hatched, and period of incubation:

Cod season at Gloucester Station, 1896-97.

Date received.	Whence.	Eggs received.	Loss during incubation.	Fry hatched.	Period of incubation.
1896.					<i>Days.</i>
Nov. 19	Kittery Point, Me.	575,000	167,000	408,000	12
20	do	509,000	136,000	373,000	13
21	do	752,000	149,000	603,000	12
22	do	1,693,000	413,000	1,280,000	12
23	do	1,817,000	414,000	1,433,000	12
24	do	2,451,000	633,000	1,818,000	12
25	do	1,251,000	661,000	590,000	11
27	do	1,784,000	1,172,000	612,000	11
28	do	2,557,000	579,000	1,978,000	13
30	do	2,649,000	683,000	1,966,000	14
Dec. 1	Kittery Point and Rockport.	1,749,000	1,219,000	530,000	14
2	Kittery Point, Me.	3,759,000	1,669,000	2,090,000	14
4	do	2,119,000	888,000	1,231,000	14
5	do	3,102,000	1,874,000	1,228,000	14
7	do	3,708,000	470,000	1,786,000	15
8	do	2,559,000	969,000	1,590,000	15
10	Kittery Point and Rockport.	1,148,000	609,000	539,000	19
11	Kittery Point, Me.	1,121,000	858,000	263,000	20
12	do	985,000	610,000	373,000	20
13	do	3,327,000	1,654,000	1,673,000	21
14	do	1,733,000	708,000	1,025,000	24
18	Kittery Point and Gloucester.	181,000	37,000	124,000	24
20	Gloucester, Mass.	4,371,000	1,732,000	1,138,000	24
21	Kittery Point, Me.	4,022,000	1,177,000	2,845,000	24
22	do	2,185,000	679,000	1,506,000	24
24	do	785,000	388,000	397,000	24
25	do	949,000	436,000	513,000	24
27	do	963,000	158,000	805,000	23
28	do	840,000	301,000	539,000	23
29	do	3,572,000	1,880,000	1,692,000	23
30	do	726,000	573,000	153,000	22
31	do				
1897.					
Jan. 2	do	1,111,000	733,000	378,000	25
6	Kittery Point and Rockport.	437,000	247,000	190,000	22
7	Kittery Point and Gloucester.	1,153,000	700,000	453,000	21
12	do	1,708,000	646,000	1,062,000	22
13	Kittery Point and Rockport.	710,000	303,000	407,000	20
12	Kittery Point, Me.	758,000	471,000	287,000	20
14	Rockport, Mass.	1,299,000	477,000	822,000	10
16	Kittery Point, Me.	624,000	200,000	424,000	20
17	do	1,137,000	867,000	270,000	19
20	do	1,919,000	682,000	1,237,000	18
22	Kittery Point and Rockport.	2,387,000	655,000	1,099,000	19
23	do	4,185,000	2,891,000	1,294,000	21
27	Kittery Point, Me.	1,601,000	1,518,000	173,000	20
29	do	1,209,000	484,000	725,000	20
30	do	1,777,000	1,179,000	598,000	22
Feb. 1	do	885,000	571,000	314,000	20
2	Kittery Point and Rockport.	1,108,000	242,000	866,000	20
5	Kittery Point, Me.	2,828,000	1,148,000	1,080,000	22
6	Rockport and Kittery Point.	3,644,000	3,139,000	505,000	21
8	do	4,124,000	1,953,000	1,965,000	21
10	Kittery Point, Me.	1,705,000	573,000	1,132,000	20
11	do	1,695,000	1,312,000	383,000	19
12	do	1,646,000	1,021,000	625,000	18
13	do	482,000	74,000	408,000	20
14	do	997,000	558,000	439,000	19
17	do	1,167,000	869,000	298,000	16
18	do	368,000	332,000	36,000	19
20	Rockport, Mass.	192,000	179,000	13,000	18
26	do	398,000	94,000	304,000	20
27	Kittery Point, Me.	2,333,000	1,212,000	1,121,000	19
28	do	942,000	388,000	554,000	18
Mar. 5	Kittery Point and Rockport.	3,985,000	1,114,000	2,871,000	19
6	Kittery Point, Me.	643,000	127,000	516,000	18
8	Kittery Point and Rockport.	1,440,000	739,000	701,000	19
9	Rockport, Mass.	503,000	337,000	166,000	18
	Total	113,140,000	50,835,000	62,305,000	

Lobster work.—Arrangements were made for collecting berried lobsters from fishermen in the vicinity of Gloucester, Boston Bay, and Kittery Point, and with the view to further extending the work the schooner *Grampus* was detailed to make collections along the Maine coast from Portland to Rockland. Permission having been obtained from the commissioners of Maine, New Hampshire, and Massachusetts for holding egg lobsters in live-boxes for the use of the Commission, Captain Hahn visited the various fishing centers in March and made the necessary arrangements with the fishermen, who agreed to deliver large females for 15 cents each and small ones for 10 cents. A small steamer was chartered to make the collections in Boston and Gloucester harbors. The season extended from April 17 to July 19, the total collection amounting to 54,532,000, from which 47,869,000 fry were hatched and planted. These results, though not as good as had been expected from the extent of the territory covered, indicated that the work can be greatly extended under favorable conditions. The weather during the early part of the season was very bad, and as a large part of the territory covered was new, the fishermen did not take much interest in the work until the season was well advanced. The greater part of the lobsters from Boston Bay came from the dealers, and by employing two or three local agents instead of one next year it is probable that better results can be secured.

The collections by localities were as follows: Boston Bay, 23,687,000; Gloucester Harbor, 5,950,000; Kittery Point, 6,966,000; the schooner *Grampus*, in Maine, 17,370,000; Marblehead, 559,000. The egg lobsters collected on the Maine coast were transferred without difficulty in the well of the *Grampus* to Gloucester, where the eggs were stripped and placed in jars, the lobsters being liberated by the vessel's crew at points along the Maine coast on the return trip. Those collected in Boston Bay were transferred by steamer, and little difficulty was experienced in transporting them during the early part of the season. On the first five or six trips they were carried in hogsheads packed in seaweed, no water being used, but as the weather grew warmer it became necessary to use water and to change it frequently en route. Ice was used, but without any apparent effect. This failure late in the season was probably due as much to the condition of the lobsters when received as to the temperature, since many of them had been shipped to Boston, from distant points, packed in ice. A vessel with a well should be used for transporting them.

The eggs were developed as heretofore, in the McDonald jar. As the temperature of the water remained below 50° until June 1, the fry did not commence hatching until after that date, but from that time on they came out very rapidly, necessitating large plants each day. The bulk of them were distributed in Massachusetts waters between Marblehead and Rockport. By means of the *Grampus* 11,665,000 were shipped to Maine and planted in the localities from which the lobsters were col-

lected, little difficulty being experienced in the transfer. During the latter part of the season several shipments were sent by rail to Portland in charge of a messenger. The first two lots were planted without loss, as the weather was cool, but the third, shipped on a very warm day, suffered heavy losses, as it was impracticable to use ice on account of its freshening the water.

Mackerel.—Early in June steps were taken to secure eggs from the trap-net fishermen in the vicinity of the station, but no mackerel were caught until June 9, when the drag nets secured a small number 15 or 20 miles offshore. Spawn-takers were detailed to attend the drag nets, and the launch visited the traps in the vicinity of Magnolia and Manchester daily. The first eggs were collected June 16, and the last on July 12, the total collections amounting to 1,108,000, from which 652,000 fry were produced. From some of the eggs collected over 90 per cent were hatched. They were handled in the McDonald tidal box in the manner adopted for the cod eggs, except that the motion given was not so violent. This was regulated by setting the siphon high enough to allow the water to rise and fall not over an inch. By doing this the full strength of the current did not reach the surface where the greater part of the eggs were, and a gentle motion was secured, just sufficient to keep them in circulation. The eggs hatched in from 3 to 5 days and were cleaned only once. They should not be changed from one box to another during the first day or two.

The following table gives a summary of the work at the station:

Species.	Eggs collected.	Fry planted.
Cod	113,000,000	62,305,000
Lobster	54,532,000	47,869,000
Mackerel	1,108,000	652,000
Total	108,640,000	110,826,000

The hatchery and pumps were taxed to their utmost capacity many times during the season, and at its close arrangements were made to enlarge the plant so as to be able to meet all emergencies another year.

WOODS HOLE STATION, MASSACHUSETTS (E. F. LOCKE, SUPERINTENDENT).

The following statement shows the kinds of fish propagated, number of eggs collected, and fry hatched and distributed during the year:

Species.	Eggs collected.	Fry planted.
Cod	65,167,000	35,053,000
Lobster	74,152,000	64,419,000
Flatfish	84,591,000	64,095,000
Tautog	1,646,000	624,000
Sea bass	241,000	193,000
Mackerel	153,000
Total	225,950,000	165,284,000

The work at the station was directed by Alexander Jones until October 10, when he was relieved by E. F. Locke, who was appointed superin-

tendent of the station. With the view to increasing the output, additional live-cars for holding adult cod were constructed and arrangements were made with the commercial fishermen to supply the fish. The *Grampus* was also detailed during the latter part of September to make collections. The first consignment of cod was delivered at the station on October 3, and by the 4th of November 9,379 fish, averaging 4 pounds and more in weight, had been delivered; 2,910 were furnished by the *Grampus* and the balance were purchased. They were apparently in first-class condition when received, and no serious losses occurred until the middle of November, when the death rate became very heavy, as many as 200 dying in 24 hours. This loss was due to injuries received in capture and transportation from fishing-grounds and to the breaking out of sores, which formed just under the skin and spread over the entire body. Of the smaller fish, 2,-00 were transferred to a small pool near the residence, many of them being affected as described above, but after remaining in the pool a short time the sores healed and they apparently recovered.

The collection of eggs commenced November 9 and continued until January 25, during which time 50,914,000 were secured from 884 spawners. The results attained were very discouraging, as the number of brood fish secured was much larger than in past years. During the winter 2,350 of the smaller ones were released, as they gave no evidence of spawning. The experience of this season seems to show that no fish weighing less than 6 pounds should be retained for spawning purposes. On January 25 all of the stock on hand, amounting to 1,500, were killed by anchor frost. From the following table it appears that not only a much smaller percentage of the fish purchased this year were spawners, but the yield of eggs per fish was also much smaller than in past years:

Year.	Brood fish.	Eggs taken.	Ripe fish.	Eggs per fish.
1880-00.....	349	8,500,000	91	93,000
1890-91.....	3,000	97,600,000	587	115,000
1891-92.....	1,620	48,600,000	444	102,000
1894-95.....	3,320	85,500,000	1,107	71,000
1895-96.....	3,836	70,800,000	415	170,000
1896-97.....	9,379	50,914,000	884	57,000
Total.....	21,504	331,914,000	3,528	608,000

In addition to the eggs collected at the station, 5,606,000 were received from Kittery Point, Me., and 8,647,000 from the fishermen near Duxbury, Mass. It having been decided in January to attempt the collection of eggs at the latter point, the mate of the *Grampus*, Mr. J. C. Conley, was placed in immediate charge of the work with a small force, and, although the collection was undertaken at the time of year when the weather is most unfavorable, the results attained were gratifying, and it seems probable that about 75,000,000 eggs can be obtained from this source next season. The total output of fry from the eggs handled at the station amounted to 35,953,000, the hatching being done, as usual, in the McDonald tidal box. The temperature of the

water having fallen to 35° in January, it was raised and maintained at from 38° to 40° by introducing steam directly into the supply pipes.

The fry distributed during the month of November were deposited in the harbor, but all those hatching after December 1 were liberated on the spawning-grounds off No Man's Land and Gayhead, part of the plants being made by the steamer *Fish Hawk* and part by a small sloop chartered for the purpose.

The following table shows in detail the daily receipts of eggs, number of fry hatched, and period of incubation :

Date.	Number of eggs received.	Number of fry hatched.	Date of hatching.	Date of planting.	Date.	Number of eggs received.	Number of fry hatched.	Date of hatching.	Date of planting.
1896.			1896.	1896.	1896.			1897.	1897.
Nov. 9	337,000	235,000	Nov. 19	Nov. 20	Dec. 17	2,298,000	1,098,000	Jan. 14	Jan. 16
10	545,000	281,000	20	21	18	758,000	431,000	14	16
12	972,000	560,000	21	22	19	1,516,000	788,000	18	22
14	426,000	302,000	24	24	21	1,420,000	979,000	19	22
16	1,162,000	640,000	25	25	22	213,000	124,000	19	22
17	063,000	397,000	26	26	26	2,370,000	1,472,000	22	29
18	1,085,000	700,000	27	28	28	1,017,000	580,000	24	29
19	758,000	400,000	29	29	30	379,000	263,000	25	29
20	1,279,000	728,000	29	30					
21	1,943,000	1,138,000	30	30	1897.				
23	1,966,000	1,080,000	Dec. 2	Dec. 3	Jan. 1	1,720,000	1,844,000	27	25
24	1,160,000	594,000	3	4	4	948,000	654,000	29	Feb. 9
25	2,487,000	1,430,000	4	6	6	758,000	521,000	Feb. 2	5
27	2,842,000	1,760,000	8	8	8	237,000	102,000	2	5
28	2,038,000	1,400,000	8	9	10	1,801,000	1,320,000	8	8
30	2,131,000	1,319,000	12	12	11	5,070,000	1,844,000	8	8
Dec. 1	1,092,000	864,000	13	14	12	427,000	230,000	11	13
4	2,180,000	1,232,000	15	18	14	2,914,000	1,539,000	11	13
5	1,188,000	655,000	16	18	16	450,000	174,000	11	13
6	758,000	490,000	17	18	18	768,000	179,000	11	12
7	474,000	91,000	21	24	21	237,000	127,000	16	17
8	2,465,000	1,712,000	21	24	22	758,000	226,000	16	17
9	592,000	296,000	23	24	23	47,000	11,000	16	17
10	663,000	362,000	25	31	24	616,000	379,000	16	17
11	1,233,000	687,000	27	31	31	948,000	314,000	26	27
			1897.	1897.	Feb. 1	1,326,000	305,000	26	27
12	544,000	379,000	Jan. 6	Jan. 9	2	1,137,000	546,000	26	27
14	2,061,000	1,019,000	7	9					
						65,167,000	35,953,000		

Flatfish.—Early in February fyke nets were set in Woods Hole Harbor and Waquoit Bay, and the first ripe fish were captured on the 15th. From that time collections were continued daily until the 15th of April, 305 ripe females being secured from the seven nets operated. The take of eggs aggregated 84,591,000, or an average of about 277,000 per fish; the yield per fish varied with the size, one female, 3½ pounds in weight, producing 1,462,000. The fish captured in Waquoit Bay were much larger than those from Woods Hole Harbor. The hatching was done, as usual, in the modified McDonald box, the period of incubation varying from 7 to 22 days, according to the temperature of the water. By the close of the season 64,095,000 fry had been hatched and distributed on suitable grounds in Buzzards and Waquoit bays.

Lobsters.—While engaged in collecting lobsters for shipment to the Pacific Coast during October and November 887,000 eggs were collected and placed in hatching-jars. They did well throughout the winter, but the losses became very heavy about the 1st of April, and as a result only 385,000 fry were hatched from them. The regular spring collections commenced on April 7. The field of operations was enlarged by the employment of an agent at Plymouth, Mass., who purchased egg

lobsters from the fishermen operating between Green Harbor and Ship Pond, including Duxbury, Kingston Bay, and Plymouth Harbor. This territory proved to be very disappointing, as the entire number of eggs received during the months of April, May, and June amounted to only 5,335,000. Collections were made at the usual points in the vicinity of Woods Hole, and steps were also taken to secure the egg lobsters captured in the vicinity of Block Island and along the Connecticut coast, a small smack being chartered for the purpose of bringing them to the station and transporting the fry back to the spawning-grounds. The lobsters brought in by the smack were much larger than those obtained from the other points, hence the yield of eggs per lobster was greater. All of the adults handled were returned to the waters after the eggs had been stripped. The eggs were handled in the universal hatching-jar, and the losses were comparatively light, the total take of 74,152,000 yielding 64,419,000 fry. The planting of the fry was commenced on May 19, and during the season several shipments were sent by rail to Plymouth and Provincetown, being carried in the ordinary transportation can without serious losses. The last deposit was made on July 13. Experiments were tried during the latter part of the season in holding and feeding young lobsters in hatching-boxes containing sand, gravel, stones, and vegetable life. Collections of crustaceans and copepods were made daily, and microscopical examinations showed that these, together with some vegetable life, formed their principal food. In only a few instances was cannibalism observed.

Mackerel.—During May and June efforts were made to collect mackerel eggs from fish caught in pound nets in the vicinity of the station, but no ripe ones were captured, though the nets were visited daily from June 16 to the end of the month. Spawn-takers sent to Edgartown to make collections from the hand-line fishermen reported that all of the female mackerel were either spent or unripe, and the only eggs received were several small shipments, aggregating 153,000, sent by the spawn-taker stationed at Barnstable, Mass. These were collected between June 19 and 26, and were forwarded to the station in Mason jars, packed in an ordinary transportation can partly filled with ice water. They were apparently in good condition when received, but died on the second day, and it is thought that the change in temperature affected them, as the water inshore where they were packed was 6° higher than that at the point of collection.

Sea bass.—Efforts were made to secure eggs of the sea bass in connection with the collection of mackerel eggs, but only two ripe fish were found. The 241,000 eggs obtained from these produced 193,000 fry, which were planted in Vineyard Sound. As large numbers of these fish are usually taken off Cotuit and Hyannis by hand-line fishermen a spawn-taker was sent to those points, but he found that the fishery had been abandoned before the commencement of the spawning season.

Tautog.—At the approach of the spawning season of this fish arrangements were made for continuing the work begun last season, and on

the 29th of June fishermen were employed to capture brood fish. Many large ones were secured, but only 24 of them were ripe. These yielded 1,646,000 eggs, from which 735,000 fry were hatched and planted in Vineyard Sound. The last eggs were taken on July 9, and the average period of incubation was from two to three days.

STEAMER FISH HAWK (LIEUT. FRANKLIN SWIFT, COMMANDING).

With the view of determining the spawning-grounds and season of the shad on the St. Johns River and other southern streams, the steamer *Fish Hawk* proceeded to Florida in January to undertake the collection and hatching of shad eggs. Palatka was reached on January 16, and an investigation of the fishing-grounds between that point and the headwaters of the St. Johns was at once commenced. It was found that the majority of the shad taken in the upper part of the river were caught in haul seines; from Volusia Bar to Lake Monroe, a distance of 50 miles, 30 of them were operated, while above the lake there were only 3. The seines were of 3½-inch mesh, 300 yards long, and 40 meshes deep. No ripe shad were caught at Sanford and an examination of those taken indicated that they would not spawn for some time.

As the water at the mouth of the Ocklawaha River was found to be well adapted for hatching purposes, a suitable anchorage was found and the vessel was removed there on January 26. The water in this section of the river was found to be slightly brackish, and it continued so until February 17. This was attributed by the inhabitants to the presence of salt springs in the lakes and river, but it seems more probable that it was caused by the banking up of the sea water at the mouth of the river by easterly gales. Tide gauges were used and regular observations of density and temperature were kept during the time the vessel was stationed at this point. As operations were being conducted on a large scale at Volusia Bar, arrangements were made with the fishermen for collecting eggs, and through the courtesy of Capt. W. A. Shaw, commanding the steamer *City of Jacksonville*, free transportation was furnished the employees of the Commission engaged in the work. Volusia Bar is situated at the entrance of the St. Johns into Lake George, and is so narrow that a seine can be stretched across it, thus effectually stopping all fish. The seines are operated from sunrise to sunset, and as soon as one is laid out and ready to be hauled in another is run out behind it, so that the shad passing up the river have little chance to escape. The catch was large throughout the season, and at times amounted to over 1,000 per day.

Spawn-takers were stationed at this point and at Welaka on February 23 for the purpose of making regular examinations of the fish captured. The ship's nets were also set regularly, but the majority of the fish taken were gizzard shad. On the 3d of March 8,000 eggs were secured at Volusia Bar. They were hatched without loss, the mean temperature of the water during incubation being 73°. The fry were strong and healthy, and exhibited no signs of weakness, as might have been expected from the high temperature of the water. They were

liberated in the middle of Little Lake George. At the time these eggs were taken it was thought that the spawning season had at last arrived, but no more were secured, though operations were continued daily. In order that the entire field might be covered, car No. 3 was stationed at Sanford, Fla., in February, and a part of the crew of the *Fish Hawk* was detailed to assist Capt. T. C. Pearce in making collections in Lake Monroe and in the river above and below it.

From February 20 to the end of March the spawn-takers from the car attended daily the seines operated at Manuel Landing, between Lakes George and Monroe. The appearance of the shad in general remained the same to the close of the season, though several ripe ones were found early in March, from which 57,000 eggs were secured. The first two lots taken were placed in the hatching apparatus as usual, but inside of twenty-four hours they were all dead. This loss was attributed to the use of water from the city works, which contains tannin. The third lot of eggs was hatched without difficulty in water taken from Lake Monroe, and the 10,000 fry resulting from them were liberated in that lake.

At Volusia Bar observations continued until the close of the month, but though large numbers of shad were being taken in the various seines and gill nets fished on that river, no ripe ones were found.

About the close of March spawn-takers were sent to Lake Harney, 35 miles up the river, but they reported that there was no fishing for shad at that point. Again, in April, one of the men returned and made several hauls with a seine, capturing 1. He was informed that small numbers of spent shad had been caught there for the past three weeks. A third trip to that lake, on April 15, resulted in the capture of 5 spent fish. On April 5, after the close of the fishing season, a seine was hired and four hauls were made at Manuel Landing, resulting in the capture of 18 roe shad, none of which was ripe.

Trips were also made to Lakes Poinsett, Winder, and Washington, but from the information gathered it seems that very few shad go beyond Lake Harney.

Though much valuable information was obtained, the results as a whole were unsatisfactory, as the main object had been to locate the spawning-grounds and to determine definitely at what season eggs are deposited. The dealers stated repeatedly that spawning fish had been captured in January and February. It may be that the headwaters of the river and the lakes are the principal spawning-grounds, but as there is no commercial fishing in those waters this was not decided.

On March 25 the *Fish Hawk* sailed for Albemarle Sound, arriving at Mackey's Ferry on April 1. As soon as possible afterward the owners of the seines, pounds, and gill nets were interviewed and arrangements made for collecting eggs. Spawn-takers were sent out on April 2 and the first eggs were brought in on the 5th. From that time to April 27 eggs were taken every day except Sunday, when fishing is prohibited by law. On April 7 the eggs collected the previous day commenced

dying, and as their general condition before being placed in the jars was good, the loss was attributed to the water. An examination by the chemist failed to show any deleterious substances, but to avoid further losses the vessel was removed to Avoca, on Salmon Creek, where it remained to the close of the season. This location proved excellent, as it was within reach of the seines owned by Dr. Capehart and Mr. Hampton. The ship's launches and five spawning boats were in constant use, and by April 27 the collection from all sources amounted to 27,901,000; 22,540,000 of these were secured from the seines at Avoca and 3,965,000 from Mr. Hampton's seines on the Roanoke River; the balance were obtained from pound nets. As the result of the season's work 16,911,000 fry were hatched and planted in the Albemarle and its tributaries, under the direction of Dr. Kendall, who had been detailed to observe their habits after liberation. The temperature of the water during the season varied from 59° to 63°.

On April 27 the vessel proceeded to Delaware Bay, the 5,473,000 impregnated eggs still on hand having been turned over to Dr. Kendall, to be hatched in floating boxes anchored in the Salmon River. Owing to the very poor circulation of the water here the loss on these eggs was very heavy; the 750,000 fry resulting from them were liberated in the Chowan River. The vessel arrived in the Delaware on May 1, and remained at Howell Cove until May 28, when it removed to an anchorage off Gloucester. For the first time in the history of the shad work on this river the efforts to collect eggs from the fisheries above the city of Philadelphia met with success. Collections commenced at once and continued without interruption until June 11, during which time 66,708,000 eggs were obtained and 42,130,000 fry hatched. Over a third of the eggs were collected in Howell Cove; the balance were obtained from gill-net fishermen and from seines above Philadelphia.

The following table shows the daily collection, number of ripe fish used, fry hatched, and average temperature of air and water:

Date.	Female fish used.	No. of eggs obtained.	No. of fry hatched.	Average temperature each day.		Date.	Female fish used.	No. of eggs obtained.	No. of fry hatched.	Average temperature each day.		
				Air.	Water.					Air.	Water.	
May 1	2	04,000	° F.	° F.	May 23	Sunday	3,376,000	° F.	° F.	
				64	59.5					63	65.5	
2	Sunday	64	59	24	74	2,982,000	2,178,000	62.5	66	
3	24	1,214,000	55	60.5	25	58	2,325,000	60	67	
4	90	3,453,000	58	60	26	45	2,302,000	60	65.5	
5	61	2,927,000	63	61	27	63	3,110,000	62	65	
6	68	2,904,000	68	61	28	39	1,901,000	1,000,000	65	65	
7	51	2,206,000	63	60	29	3	142,000	1,155,000	61	66	
8	4	199,000	50,000	60	60	30	Sunday	1,680,000	64	66	
9	Sunday	500,000	62	62.5	31	54	2,767,000	2,000,000	66	66.5	
10	34	1,211,000	956,000	68	63.5	30	80	1,125,000	2,404,000	63.5	66	
11	82	3,369,000	1,994,000	66.5	64.5	June 1	2	23	1,025,000	1,726,000	61	66
12	40	1,550,000	2,800,000	71	65	3	46	2,054,000	72.5	66	
13	48	2,761,000	2,337,000	66	66	4	18	954,000	1,500,000	72	68	
14	46	1,942,000	273,000	67.5	66.5	5	1,409,000	69	69	
15	14	715,000	1,500,000	64	65	6	Sunday	649,000	68	69	
16	Sunday	1,851,000	62	64	7	10	613,000	1,191,000	69.5	68	
17	121	5,930,000	1,998,000	64.5	64.5	8	574,000	69	67	
18	87	4,297,000	1,076,000	65	64.5	9	6	255,000	61	66.5	
19	87	3,422,000	1,122,000	69	65	10	11	378,000	67.5	66	
20	93	3,611,000	670,000	68.5	65	11	16	547,000	380,000	70	67	
21	45	2,169,000	1,000,000	63	65							
22	7	294,000	3,597,000	64	65							
							1,511,06,708,000		43,046,000			

Several times during the season the capacity of the vessel was taxed to its utmost, and on two occasions it was found necessary to transfer eggs to other stations. In addition to the jar, various forms of apparatus, such as the Seth Green boxes, tidal boxes, and aquaria, were employed temporarily in hatching.

The shad work was discontinued on June 14 and the vessel proceeded to Woods Hole, arriving there June 16. It was the intention to remain here for a time, to cooperate in the collection of mackerel eggs near Edgartown, but after waiting for several days and failing to secure any eggs she proceeded on June 24 to Casco Bay and anchored in Orr Island Harbor. This location was selected as the base of operations on account of its being the headquarters of the mackerel fishermen; it was also in easy communication with Portland, where large numbers of lobsters are collected. Arrangements were at once made for the spawn-takers to attend the pound nets in the vicinity and to accompany the drag-net fishermen regularly on their trips. The weather at this time was so bad that the drag-netters were often prevented from going out, and on July 13 a southwesterly gale completely wrecked the pounds at two of the fisheries. As a result the total number of mackerel eggs secured amounted to only 999,880, most of which were taken from the pounds on Jaquish Island. The period of collection extended from June 25 to July 8.

In view of the difficulties experienced the past season in hatching eggs of the mackerel, Dr. J. P. Moore was employed to make a special study of the development of the egg, with the view to suggesting some practical improvements in the hatching methods.

The following are the most important of the hatching processes experimented with: Increase of density from the normal 1.0224 to 1.0252 by the addition of salt; floating box in supply tank; McDonald jar with supply covered; inverted cod-jar with tidal flow; jar with bottom feed and cheese-cloth top; jar containing salt water to which new water was added from time to time; and, finally, the tidal-box system. There appeared to be no marked improvement in any of the methods over that of the tidal-box system, which last year hatched over 70 per cent in one instance. As far as could be observed the difficulty appeared to be with the egg and not with the hatching apparatus. Many fish were found to be spent soon after the commencement of operations, and eggs were found in all stages of development throughout the season. At the end of July fish were noticed that had not yet spawned. There is no difficulty in fertilizing the eggs, as all taken appear to be impregnated.

It has been stated in previous reports that the eggs lacked sufficient vitality to produce healthy fry, and it was thought that the good eggs were given up while the fish were endeavoring to escape from the net. Nothing occurred during the season to disprove this, but from further investigations it would seem that the greater number of the mackerel spawn offshore. This view is substantiated by the condition of the fish when taken, and by the fact that only with offshore winds

were eggs found in the surface tow net used. Before coming to any definite conclusions on this point, however, it would be necessary to conduct a series of offshore tows, and to carefully examine the eggs under a microscope in order to note their development, if impregnated, and to compare it with that of eggs artificially treated.

Lobsters.—The *Grampus*, which had been engaged in collecting seed lobsters and transferring them to Gloucester, was instructed to cooperate with the *Fish Hawk* on the arrival of the latter in Casco Bay. During the season 372 lobsters were received, from which 4,877,935 eggs were secured, and 4,616,065 fry hatched and liberated 2 miles offshore, directly in the center of the bay. The direction of the wind and the current were considered in making the plants, so as to provide against the fry being swept toward the shore.

Experiments were also conducted in the holding of lobster fry. They were placed in boxes with a good circulation of water, individually and in lots of fifty, rock, gravel, and rockweed being provided so as to imitate as nearly as possible the conditions of nature. They were fed with towings from the surface of the water in the vicinity of the ledges. It was soon found that they would not live under these conditions, and they were removed to floating boxes in the supply tank and overboard. Notwithstanding these efforts it was impossible to keep them alive longer than 13 days. Death was not caused by starvation, as their stomachs were found to contain such food as copepods, diatoms, vegetable debris, and fragments of algæ. In but few instances could the mortality be attributed to cannibalism, as only one specimen of the many examined was found to contain any portion of a lobster. It was also noticed that those confined separately lived no longer than those in lots of fifty.

Toward the end of the season young lobsters in the second, third, and fourth stages of molting appeared in the jars which contained eggs and fry in the first stages. Most of these when first noticed must have been three or four weeks old. As the increase in size became apparent they were placed in a jar by themselves and fed on lobster eggs. They were brought to Woods Hole on the return of the vessel on July 31, but they all died the night of the arrival, probably because of the change in the temperature of the water, which showed an increase of 10°. They had passed the fourth stage and taken on the characteristics of the adult; the largest were over five-eighths of an inch in length. Of adult lobsters handled during the season, 332 were liberated in open waters and 40 died in transportation.

BATTERY STATION, MARYLAND (ALEX. JONES IN CHARGE).

Ice disappeared from the Susquehanna early in March, and, as reports from the lower part of Chesapeake Bay indicated a very early season, the station was gotten ready for operations by April 1, and on April 8 the first lot of eggs were received. The weather turned cool, however, and the temperature of the water remained so low that the full force of employees was not taken on until April 19. From that date collections

REPORT OF COMMISSIONER OF FISH AND FISHERIES. XLIII

continued daily until June 5, the total take for the season amounting to 71,145,000, not including 3,000,000 received from the steamer *Fish Hawk*. From these eggs 50,682,000 fry were hatched and distributed. A shipment of 994,000 eggs was sent to Nashville during the season for exposition purposes.

The following table shows in detail the daily collections of eggs, fry hatched and planted, and average temperature of the air and water:

Date.	Eggs received.	Loss.	Hatching.		Number of fry planted.	Average temperature.	
			Date.	Number hatched.		Air.	Water.
						°F.	°F.
Apr. 8	35,000	35,000				59	53.4
14	60,000	60,000				58	54
15	58,000	58,000				58	54
16	279,000	149,000	Apr. 28	130,000	150,000	58	54.5
17	180,000	96,000	Apr. 29	84,000	84,000	55	54.0
18	388,000	172,000	Apr. 29	216,000	216,000	55	54.6
19	247,000	131,000	Apr. 29	116,000	116,000	55	54.6
21	321,000	213,000	Apr. 29	108,000	108,000	55	54.7
22	78,000	41,000	Apr. 29	37,000	37,000	55.3	55.7
23	1,725,000	645,000	May 1	1,080,000	1,080,000	56.7	55.7
24	2,938,000	973,000	May 1	1,965,000	1,965,000	57	55.7
25	420,000	218,000	May 2	202,000	202,000	57	55.7
26	1,254,000	1,184,000	May 3	70,000	70,000	58	50
27	2,395,000	973,000	May 4	1,422,000	1,422,000	58.3	56.2
28	1,219,000	298,000	May 6	914,000	914,000	58	56.4
29	4,729,000	1,457,000	May 7	3,272,000	3,272,000	59	56.4
30	6,902,000	2,207,000	May 8	4,695,000	4,695,000	60	57
May 2	428,000	185,000	May 9	243,000	243,000	60	57
3	2,018,000	687,000	May 11	1,321,000	1,321,000	60.4	58.1
4	1,270,000	401,000	May 14	869,000	869,000	60.7	59
5	894,000	103,000	May 15	791,000	791,000	60.7	59.3
6	448,000	132,000	May 16	316,000	316,000	61	60
7	550,000	155,000	May 16	395,000	395,000	61.3	60
9	951,000	126,000	May 17	825,000	825,000	61.3	60
10	1,301,000	841,000	May 18	960,000	960,000	61.5	61
11	1,142,000	843,000	May 18	799,000	799,000	61.5	61
12	929,000	252,000	May 19	677,000	677,000	61.7	61.1
13	1,609,000	389,000	May 19	1,220,000	1,220,000	65	63
15	636,000	196,000	May 21	440,000	440,000	65.9	64
16	203,000	71,000	May 21	139,000	139,000	65.9	64.3
17	1,189,000	280,000	May 23	900,000	900,000	66	64.7
18	2,004,000	650,000	May 23	1,354,000	1,354,000	66	65
19	2,377,000	636,000	May 25	1,741,000	1,741,000	66	65.6
20	5,888,000	1,149,000	May 26	4,739,000	4,739,000	66.3	65
20	1,800,000	684,000	May 26	1,116,000	1,116,000	66.3	65
21	2,898,000	760,000	May 27	1,638,000	1,638,000	66.3	65.2
21	*663,000	155,000	May 27	508,000	508,000	64.7	65.1
22	*198,000	32,000	May 28	166,000	166,000	65	65
22	1,764,000	678,000	May 28	1,086,000	1,086,000	65.7	65.3
23	816,000	320,000	May 29	496,000	496,000	65.7	65.3
24	45,000	10,000	May 30	35,000	35,000	66	65.7
25	346,000	34,000	May 30	312,000	312,000	66	65.6
26	340,000	30,000	May 30	310,000	310,000	66	65.7
27	1,544,000	362,000	May 31	1,182,000	1,182,000	66.3	65.9
28	3,416,000	816,000	June 1	2,600,000	2,600,000	66.3	65.9
29	2,580,000	618,000	June 2	1,962,000	1,962,000	66.3	66
30	1,432,000	513,000	June 3	919,000	919,000	67	66.1
31	3,667,000	704,000	June 4	2,449,000	2,449,000	67	66
June 1	2,260,000	415,000	June 5	1,845,000	1,845,000	67.3	66.7
2	1,030,000	178,000	June 7	861,000	861,000	68	67.8
3	1,574,000	623,000	June 8	951,000	951,000	68.3	67.8
4	805,000	325,000	June 9	480,000	480,000	68.3	67.2
5	400,000	95,000	June 11	305,000	305,000		
May 3	Total	74,145,000		50,682,000	50,682,000		
		†1,280,000		500,000	450,000	57	58

* Steamer *Fish Hawk*.

† Eggs of striped bass.

Storms were very frequent throughout the season, and as they usually occurred at slack water, between sunset and midnight, the daily collections were materially interfered with, though the total take exceeded that of any season since 1888. It is worthy of mention that 11,000,000

eggs were obtained between midnight and daylight, more than 3,000,000 between 8 a. m. and noon, and 6,000,000 between noon and night.

Contrary to past experience, the eggs collected during the day were of excellent quality and produced strong, healthy fry. This year the number of fry hatched amounted to 72 per cent of the total take of eggs. The fishermen in the neighborhood cooperated with the superintendent throughout the season, and furnished 26,000,000 eggs, or nearly three times the number furnished last year, at a rate of \$20 per 1,000,000.

Striped bass.—For several years the station force has been on the lookout for striped bass or rockfish eggs, and on May 3 the spawn-taker attending the Carpenter Point seine brought in 1,280,000, which he had collected from a fish weighing 12 pounds. The eggs were nearly transparent and measured one-seventh of a linear inch, or 24,552 to the quart. After attempting to hatch them in the McDonald jar it was found necessary to improvise a special form of apparatus somewhat similar to the McDonald tidal box, owing to the fact that there is very little difference between the specific gravity of the water and that of the eggs. The improvised form consisted of four bell aquaria inverted and placed in a box supplied with water through a $\frac{3}{4}$ -inch tube and discharged through a 1-inch tube, thus giving a rise and fall of $5\frac{1}{2}$ inches every 8 minutes. By the afternoon of May 6 the hatching was completed, the mean temperature during the period of incubation being 58°. The fry resulting from these eggs (estimated at 450,000) were liberated in the Susquehanna River near Port Deposit. The small percentage hatched was occasioned partly by the muddy condition of the water and partly by imperfect circulation due to the character of material used for covering the jars. For the purpose of closer observation during the period of incubation, two small glass jars were placed in a bell aquarium fitted with tidal motion. The water used was first run through a charcoal filter.

BRYAN POINT STATION, MARYLAND (S. G. WORTH, SUPERINTENDENT).

In August and September important improvements were made under the direction of the superintendent, embodying repairs to the boiler-house, seine-house, and boat-house; the wharf was repaired and protected against damage from ice by driving piles 20 feet away from the corners, on a line with the end, and a well 18 $\frac{1}{2}$ feet deep was excavated, which affords a copious supply of cold, clear water. The station has heretofore been dependent on a very unsatisfactory spring and upon river water, which caused sickness.

A large amount of worn-out property, including seines, seine boat, and other fishing apparatus, was condemned and sold at auction. A topographical survey of the station was made during the year, and an estimate was submitted by the superintendent for a large hatchery, where the entire product of the station can be cared for, thus obviating the necessity of transferring the eggs to Central Station.

In view of the receipt of large numbers of shad during March, 104,000 being received from the 14th to the 28th, preparations were made

to open the station two weeks in advance of the usual time. Mr. L. G. Harron was detailed to assist the superintendent in field work.

Special attention is called to the fact that although immense numbers of shad were taken in March, the catch during the spawning period (April 15 to June 30) was much smaller than that of any year since 1887, and this accounts for the poor results secured. A few ripe fish were found as early as April 2, but the regular collections did not commence until April 14. The following table shows the daily collections of eggs and the source of supply:

1897.	Haul seines.	Gilliers.	Daily total.	1897.	Haul seines.	Gilliers.	Daily total.
April 14	472,000	472,000	May 8	78,000	468,000	546,000
15	356,000	177,000	533,000	9	1,353,000	1,353,000
16	481,000	7,000	488,000	10	422,000	2,789,000	3,211,000
17	522,000	120,000	642,000	11	280,000	1,447,000	1,736,000
19	485,000	600,000	1,085,000	12	63,000	1,271,000	1,334,000
20	288,000	336,000	624,000	13	271,000	1,377,000	1,648,000
21	184,000	122,000	306,000	14	1,408,000	1,408,000
22	80,000	671,000	751,000	15	171,000	729,000	900,000
23	203,000	257,000	460,000	16	241,000	241,000
24	461,000	1,010,000	1,471,000	17	605,000	605,000
25	871,000	2,179,000	3,050,000	19	641,000	641,000
26	653,000	1,696,000	2,349,000	20	670,000	670,000
27	60,000	943,000	1,003,000	21	387,000	387,000
28	283,000	604,000	887,000	22	847,000	847,000
29	130,000	208,000	338,000	23	1,483,000	1,483,000
30	116,000	136,000	252,000	25	318,000	318,000
May 1	384,000	1,145,000	1,529,000	27	795,000	795,000
2	511,000	598,000	1,109,000	28	621,000	621,000
5	400,000	611,000	1,011,000	29	401,000	401,000
6	92,000	1,670,000	1,662,000	Total ...	8,471,000	31,230,000	39,707,000
7	145,000	386,000	531,000				

Over 90 per cent of the eggs were from the lower river, whereas only about 15 per cent were obtained from that field the previous year. As the daily collections were very small, half of the temporary employees were discharged on May 15, and most of the remainder on the 29th, sufficient force being retained to dismantle the station and care for the property. On April 20 the daily shipment to Central Station was frozen, though the eggs were closely covered with oil-cloth and placed on the forward deck of the launch, where they were exposed to sunlight. This is the first instance of shad eggs freezing on the trays during the spawning season. A system of temperature observations, embracing 25 miles of spawning territory, was inaugurated on April 20, and it is thought, by continuing the work from season to season, that valuable deductions may be made as to the spawning habits of the shad. During May an effort was made to ascertain the extent to which young shad were frequenting the spawning-grounds at Stony Point. The station was closed on June 7.

Following are the mean temperatures of air and water for March, April, and May:

Month.	Air.	Water.
March	48.25	45.25
April	55.76	54.50
May	60.38	64.73

XLVI REPORT OF COMMISSIONER OF FISH AND FISHERIES.

The following table shows the temperatures of water by weeks, during the shad season, from 1887 to 1897. It will be found of interest in connection with the table on the opposite page:

Year.	Week ending Feb. 7.			Week ending Feb. 14.			Week ending Feb. 21.			Week ending Feb. 28.			Week ending Mar. 7.		
	Max.	Min.	Mean.	Max.	Min.	Mean.	Max.	Min.	Mean.	Max.	Min.	Mean.	Max.	Min.	Mean.
1887	39	30	39	42	40	40.80	43	41	42.17	44	40	43.37	42	40	41
1888	35	35	35	35	35	35	36	35	35.28	39	36	37.07	38	37	37.53
1889	40	36	38.07	39	36	36.32	37	36	36.21	36	36	36	37	36	36.60
1890	46	42	44.07	45	41	42.28	48	42	44.42	48	42	44.35	48	42	44.67
1891	43	40	41.14	46	40	41.66	47	41	44.57	47	42	45.38	42	40	41.42
1892	42	35	38.50	44	37	39.21	44	38	39.35	47	39	42.85	46	41	42.90
1893	36	34	34.85	36	34	34.80	37	34	35.57	38	34	35.42	40	35	36.80
1894	40	38	38.28	40	38	39.58	44	38	39.32	42	37	38.32	46	38	41.75
1895	36	34	34.35	35	34	34.17	35	34	34.82	36	35	35.17	40	36	38
1896	40	39	39.92	40	40	40	40	36	38.32	38	36	36.50	40	38	38.96
1897	36	34	35.03	36	36	36	38	36	36.78	40	38	39.10	42	39	41.03

Year.	Week ending Mar. 14.			Week ending Mar. 21.			Week ending Mar. 28.			Week ending Apr. 4.			Week ending Apr. 11.		
	Max.	Min.	Mean.	Max.	Min.	Mean.	Max.	Min.	Mean.	Max.	Min.	Mean.	Max.	Min.	Mean.
1887	43	41	42.21	43	41	41.71	44	41	42.71	44	42	42.30	52	43	47.17
1888	39	34	37.21	40	34	36.21	40	38	39.07	48	40	44.14	52	48	50.02
1889	40	37	39.07	45	41	43.39	48	45	46.82	50	48	48.02	52	50	50.50
1890	48	41	42.67	48	44	45.85	49	45	47.17	50	47	48.10	53	50	51.46
1891	42	39	40.38	42	39	41.33	40	41	44.04	40	42	44.42	40	44	45.04
1892	46	41	43.60	44	39	41.04	40	40	43.14	52	45	47.28	56	52	53.80
1893	44	37	40.64	44	40	41.53	46	42	44.14	54	45	48.64	54	52	53.21
1894	50	46	48.35	54	50	51.35	56	49	52.42	50	46	48.03	52	48	50.17
1895	48	40	41.82	43	41	42.32	46	42	43.71	48	45	47.14	54	48	59.14
1896	41	38	39.71	41	38	39.50	43	40	41.03	46	44	45.17	47	45	46.07
1897	45	42	43.32	50	44	46.21	51	48	49.80	52	48	50.14	53	52	52.21

Year.	Week ending Apr. 18.			Week ending Apr. 25.			Week ending May 2.			Week ending May 9.			Week ending May 16.		
	Max.	Min.	Mean.	Max.	Min.	Mean.	Max.	Min.	Mean.	Max.	Min.	Mean.	Max.	Min.	Mean.
1887	55	52	54.30	55	54	54.21	57	55	55.71	66	57	62.55	68	66	67.28
1888	52	50	51.22	52	50	50.55	58	51	55.55	64	58	60.64	68	63	64.53
1889	55	52	52.64	58	52	55.67	58	56	57.71	62	54	57.84	68	61	65.64
1890	58	51	54.60	60	56	57.35	62	58	59.42	64	60	62.07	65	60	62.53
1891	58	46	52.28	64	58	61.33	64	62	63.04	64	60	62	65	60	62.28
1892	52	50	50.85	53	50	51.85	62	52	56.23	68	60	65.09	68	64	65.52
1893	56	52	54.53	55	50	53.36	56	50	53.09	60	56	58.14	66	58	62.47
1894	54	48	50.50	60	54	58.35	66	60	62.29	70	64	68.32	70	68	69.64
1895	54	52	53.32	61	53	58.67	62	57	59.57	70	58	63.39	73	62	67.35
1896	62	56	59.84	66	62	64.56	64	62	63	62	64.64	73	67	70	
1897	56	52	53.96	59	54	56.03	62	60	60.64	63	60	61.60	66	63	64.30

Year.	Week ending May 23.			Week ending May 30.			Week ending June 6.			June 6 to 10.		
	Max.	Min.	Mean.	Max.	Min.	Mean.	Max.	Min.	Mean.	Max.	Min.	Mean.
1887	72	68	70.35	73	72	72.67	72	72	72	72	70	71.17
1888	63	61	62.14	65	61	62.75						
1889	70	66	68.64	69	64	65	70	65	67.92	69	65	67.25
1890	68	64	65.92	68	64	66.45	73	69	70.14	74	72	73.61
1891	68	61	64.61	66	62	64.42	70	62	67.42	73	66	68.42
1892	69	65	67.33	66	62	64.57	74	62	68.66	74	70	72.19
1893	69	60	63.57	70	66	69.09	75	68	71.23	76	74	75
1894	70	67	69.10	68	64	65.71	69	62	65.07	77	68	72.71
1895	62	60	61.28	72	62	65.32	82	70	76.28	80	75	77.50
1896	75	72	73.28	72	70	71.78	73	71	72.03	76	73	75.21
1897	67	66	66.14	68	67	67.76	71	68	69	71	70	70.12

The following table shows the receipts of shad from the Potomac River, at Washington, D. C., by weeks during the season, from 1887 to 1897. The data were furnished by Mr. Gwynn Harris, inspector of marine products:

Year.	Non-spawn fish.									
	Week ending Feb. 7.	Week ending Feb. 14.	Week ending Feb. 21.	Week ending Feb. 28.	Week ending Mar. 7.	Week ending Mar. 14.	Week ending Mar. 21.	Week ending Mar. 28.	Week ending Apr. 4.	Week ending Apr. 11.
1887.....			2	2	64	208	464	3,325	4,811	26,038
1888.....					2	1			2,963	25,922
1889.....						1	221	3,020	16,802	42,463
1890.....		4	15	19	292	391	4,103	15,916	43,520	97,375
1891.....			2	12	38	53	491	2,447	7,070	15,761
1892.....				4	2	52	132	1,442	16,493	71,056
1893.....						38	477	5,914	48,170	58,115
1894.....	3	2	5	15					23,631	67,325
1895.....						89	1,897	15,743	70,352	134,800
1896.....	1	3	1	2		39	101	3,642	23,338	49,450
1897.....				16		25	1,060	24,986	80,120	84,373

Year.	Spawn fish.									Total.
	Week ending Apr. 18.	Week ending Apr. 25.	Week ending May 2.	Week ending May 9.	Week ending May 16.	Week ending May 23.	Week ending May 30.	Week ending June 6.	June 6 to June 10.	
1887.....	50,045	48,634	33,655	49,921	22,951	17,921	5,760	3,881	1,398	209,110
1888.....	61,611	61,611	53,302	51,363	23,442	14,307	7,790	5,237	893	308,444
1889.....	88,832	110,254	56,130	72,066	31,979	14,886	8,002	2,308	1,544	448,577
1890.....	97,070	71,895	45,580	24,328	11,822	3,261	1,369	1,481	337	419,390
1891.....	87,341	97,600	53,918	21,211	15,194	10,920	3,412	2,061	258	317,789
1892.....	60,592	38,753	28,173	22,285	8,468	4,655	3,476	8,961	1,355	260,882
1893.....	55,431	55,392	35,963	18,029	15,220	9,520	3,820	1,514	375	307,978
1894.....	83,859	79,067	55,870	22,470	20,165	9,044	7,234	12,410	2,777	383,507
1895.....	126,290	106,501	38,123	56,874	28,642	20,449	13,112	8,826	1,612	623,310
1896.....	128,050	53,300	32,852	22,973	13,218	7,937	3,307	4,346	592	313,160
1897.....	60,250	24,079	18,568	10,230	7,273	3,400	1,882	1,151	210	396,899

CENTRAL STATION, WASHINGTON, D. C. (S. G. WORTH, SUPERINTENDENT).

During the summer the superintendent was detailed to make an investigation in the neighborhood of Weldon, N. C., with the view to determining the extent to which the river shrimp, *Palamonetes exilipes*, enters into the food of the bass and crappie, and to arrange for the extension of its geographical range as a natural food for trout and other edible fishes. They were found in many of the ponds and streams of Halifax and Northampton counties, and shipments were sent to Washington, D. C., Wytheville, Va., and Neosho, Mo. It was learned that they form an important part of the natural food of bass, crappie, and other predaceous fishes, and that they can be successfully shipped in pails of water by express for distances requiring not over seven hours time. Part of the consignment sent to Washington were put in a trout stream near Leesburg, Va. An examination of the pond in Washington during the month of May showed the presence of egg-bearing shrimp.

As in former years, the fish-cultural work included the distribution of the year's production of fish from the Fish Commission ponds, the hatching of shad eggs collected on the Potomac River, and of a few eggs of the quinnat salmon, brook, rainbow, Loch Leven, and lake trouts, which had been transferred from other stations during the winter for the purpose of illustrating fish-cultural methods.

XLVIII REPORT OF COMMISSIONER OF FISH AND FISHERIES.

The following table shows the number of eggs received and the fish distributed:

Species.	Eggs received.	Fry distributed.
Brook trout.....	3,000	2,202
Lake trout.....	5,000	4,338
Loch Leven trout.....	3,000	2,200
Rainbow trout.....	10,000	7,479
Quinnat salmon.....	10,000	7,516
Shad.....	40,350,000	25,346,000
Total.....	40,390,000	25,369,744

The first consignment of shad eggs was received from Bryan Point on April 14, and shipments continued uninterruptedly from that time until the 29th of May, 31,877,000 of the 39,719,000 shipped being received in good condition. A consignment of 640,000 was also received from the Delaware River on May 22.

During the season 25,346,000 fry were hatched and distributed, and 2,070,000 eggs were shipped to Nashville for exposition purposes; the balance were lost during incubation. The eggs were transferred from Bryan Point by means of the Fish Commission launch instead of by passenger boat, as in past years.

At the close of the year the superintendent was detailed for duty in connection with the construction of the station at Erwin, Tenn.

AQUARIUM AT CENTRAL STATION (L. G. HARRON, IN CHARGE).

In October arrangements were made to restock the aquarium with salt-water fishes from Chesapeake Bay, but owing to the prevalence of heavy gales it was impossible to obtain good collections. Fresh-water fishes were collected from time to time in the Potomac River, and consignments of trout and salmon were received from the New England stations.

Comparatively little difficulty was experienced during the year with fungus or disease of any kind.

During March and April 19 yellow perch spawned in the aquarium, but efforts to hatch their eggs were unsuccessful; this was attributed to the presence of alum in the filtered water. Two rainbow trout spawned early in March and another on May 12; none of the eggs hatched, though efforts were made to save them. The goldfish spawned in April and May and the eggs were placed in a separate aquarium in the greenhouse, where they were hatched.

The fresh-water fishes, with the exception of the lake trout, were held without loss until May 6, when a part of the steelhead trout and quinnat salmon were transferred to Nashville. The balance were retained with comparatively light losses until June 18, when they were liberated in a small spring fed pond about 10 miles from Washington. Several adult rainbow trout, weighing from 1½ to 2 pounds, a number of 2-year-olds, and a few steelheads were retained in the aquarium for experimental purposes, and lived until July 4, when they died at a temperature of 82°.

REPORT OF COMMISSIONER OF FISH AND FISHERIES. XLIX

From June 18 to July 4 the water temperature was as follows:

Date.	6 a. m.	Noon.	6 p. m.	Date.	6 a. m.	Noon.	6 p. m.
1897.				1897.			
June 18.....	°F. 74	°F. 74	°F. 74	June 27.....	°F. 77	°F. 77	°F. 77
19.....	74	75	75	28.....	77	77	77
20.....	75	75	76	29.....	77	77	77
21.....	75	75	75	30.....	77	78	78
22.....	75	75	75	July 1.....	78	78	78
23.....	75	75	75	2.....	78	80	80
24.....	75	76	76	3.....	80	81	81
25.....	76	76	76	4.....	81	81	82
26.....	77	77	77				

The following shows the number and kind of salt and fresh water fishes exhibited during the year:

Species.	No.	Species.	No.	Species.	No.
Fresh water:		Fresh water—Continued.		Salt water—Continued.	
Large-mouth black bass..	295	Pickeral.....	5	Pinfish.....	3
Small-mouth black bass..	32	Channel cat.....	10	Scup.....	30
Rock bass.....	100	Yellow cat.....	30	Cronker.....	20
Crappie.....	120	Chub sucker.....	6	Pigfish.....	4
White bass.....	3	Red stoker.....	4	Striped mullet.....	9
Yellow bass.....	1	Leather carp.....	6	Flounder.....	8
Rainbow trout.....	165	Shad.....	2,700	Mummichog.....	20
Brook trout.....	175	Sunfish.....	120	Tautog.....	24
Lake trout.....	193	Mill roach.....	20	Toadfish.....	12
Swiss lake trout.....	150	Common eel.....	12	Hog-choker.....	14
Steelheads.....	300	Lacepede dace.....	25	Moonfish.....	4
Quinnat salmon.....	174	Fresh-water shrimp.....	200	Swolfish.....	19
Atlantic salmon.....	29	Bullfrog.....	12	Striped bass.....	6
Yellow perch.....	66	Crawfish.....	100	Black drum.....	3
White perch.....	40	Fresh-water terrapin.....	4	Shoepshead.....	3
English perch.....	12	Snapping turtle.....	2	Skate.....	2
Paradise fish.....	12	Salt water:		Sting-ray.....	1
Golden tench.....	300	Sea trout.....	19	Lobster.....	4
Goldfish.....	65	Sea bass.....	40	Hermit crab.....	12
Golden ide.....	5	Sea robin.....	2	Blue crab.....	15
Pike.....	1	Spot or goody.....	32	Medusa.....	1

FISH COMMISSION LAKES, WASHINGTON, D. C. (RUDOLPH HESSEL IN CHARGE).

During the fall months the following fish, resulting from the crop of the previous spring, were distributed: Large-mouth black bass, 38,492; small-mouth black bass, 2,688; rock bass, 5,070; shad (estimated number), 1,500,000.

At the close of the previous fiscal year 12,270 young large-mouth black bass had been transferred from the breeding-ponds to the tanks and the small rearing-ponds. This work was continued during the summer, a total of 48,822 large-mouth and 2,976 small-mouth bass being secured.

The losses up to the time of distribution amounted to 11,410, of which 1,080 were the small-mouth species. The heaviest mortality occurred in June, caused by the high temperature and the muddy condition of the water. Their food during the early summer consisted of chopped fish (carp and tench reared at the station), and when the supply was exhausted, fishes purchased from the market were substituted. The bass refused to take the fresh-water species, but the various salt-water fishes, particularly the butter-fish and the sea trout, proved very accept-

able. These were purchased at a rate of 3 cents per pound. In preparing fish as food the scales and gills should be carefully removed.

With the view to enlarging the output of bass, spawning-ponds were constructed along the south banks of the north and south ponds during the winter, and the stock was increased by the transfer of several hundred large-mouth breeders from Quincy and small-mouth breeders from Lake Erie. On the 15th of April 20 adults were placed in each of the partitions of the north pond and the same number of small-mouth bass were placed in the various partitions of the south pond. Spawners were also placed in Pond No. 6 and in a number of the small ponds on the terrace in front of the cottage.

As good results had been attained at Wytheville Station the previous year by the use of artificial nests, all of the ponds were provided with them, in addition to piles of gravel. The nests used were of two forms, one being simply a cement plate 20 inches in diameter, covered with coarse gravel; the other, the Seagle nest, described in the Report for 1896, page 48. The fish commenced spawning on April 18, and it was noticed that they deposited their eggs on the artificial nests quite as readily as on the natural nests of gravel.

The temperature of the water at the opening of the spawning season was 45°. Fungus developed after a few days on the first eggs deposited in partitions 1 and 2 of the north pond and Pond No. 6, but the others did well, and on April 26 young fish were seen in both the north and south ponds.

Owing to the fact that the ponds were not dried during the winter, there was an immense growth of algæ, which not only interfered materially with the removal of the fry, but prevented close observation of their movements. As an examination of the ponds showed them to be abundantly stocked with microscopic food, artificial feeding was not commenced until the bass were about two weeks old.

During the month of May there was every reason to expect a large crop of both species, but late in June a small bug belonging to the family of *Notonectidae* made its appearance and destroyed large numbers of the young fish.

An insect which belongs to the *Dytiscidae* family appeared later and caused even greater damage. It attacked the young bass in large numbers, killing and eating in a few minutes a fish 1½ inches long, nothing remaining but the skeleton. Though little is known of the natural history of this insect, it has heretofore been thought that its food consisted solely of dead flesh. The pests fly over into the ponds at night from the river, and the only way to prevent their ravages is to cover the ponds with very fine meshed netting.

At the close of the year, owing to heavy losses caused by the insects referred to, very few of the young fish remained in the small ponds.

Crappie.—As the demand for this species is constantly increasing, a supply of adults was brought to the station from Quincy in the fall, and early in April 23 of them were placed in Pond No. 5 and the remainder

in the acclimatization pond, No. 20, which has an area of 17,500 square feet. In Pond No. 5, where there was very little vegetation, a close watch was kept, with the view of noting the spawning habits of the fish, but in no instance were they observed to nest, though a few fry appeared in June. The vegetation in Pond No. 20 is very dense, and the results attained were apparently much better, as hundreds of fry an inch in length were observed during the latter part of June. The crappie are so delicate that it is impracticable to handle them during warm weather, and no effort was made to remove the young brood, but the old fish were taken out and placed in a smaller pond.

Golden ide.—A part of the stock of golden ide was placed in Pond No. 4 and commenced spawning on April 21. The temperature of the water at that time was 54°, but it fell to 41° on the 24th, causing the loss of all the eggs. A few days later 16 specimens which had been set aside for shipment to Nashville spawned, the temperature at the time being 58°. These eggs were successfully hatched within 10 days, and at the close of the year there were several hundred of the young fish on hand. Their food consists of cornmeal and flour.

All of the spotted catfish and rock bass on hand were shipped to Nashville for exhibition purposes. As usual, large numbers of carp and tench were hatched to be used as food for the bass, and a sufficient number of goldfish were reared for stocking the public parks.

During the winter the old tool-house, the fences, and the partitions around the ponds were removed; a driveway was constructed from Executive avenue to the office, and the grounds were further improved by the planting of ornamental flower beds.

WYTHEVILLE STATION, VIRGINIA (GEORGE A. SEAGLE, SUPERINTENDENT).

The condition of the ponds and buildings was such that it became necessary to expend \$800 in improvements during the fall. These consisted of the subdivision of the bass ponds into 9 spawning-ponds by the construction of wooden and earthen partitions, and the painting and repairing of the hatchery and superintendent's residence.

The stock of fish on hand at the beginning of the year is shown in the following table:

Species.	Calendar year in which fish were hatched.				
	1896.	1895.	1894.	1893.	1892 or before.
Rainbow trout	117,300	1,400	560	805	1,830
Black bass					24
Rock bass					140
Total	117,300	1,400	560	805	1,994

At the time of distribution in the fall the trout numbered 81,954; 2,200 of these were retained for breeding purposes and the remainder were planted in public and private waters. Very few black bass were reared at the station, owing to the condition of the ponds, but the out-

put was increased by the transfer of 13,562 from Central Station and 234 from Quincy, Ill. The output of rock bass was 11,485 yearlings and 70 adults reared at the station and 2,550 yearlings transferred from Neosho.

Rainbow trout.—The brood stock at the station in November consisted of 1,623 fish from 4 to 8 years old, 700 three-year olds, 515 two-year olds, and 1,200 yearlings. The spawning season commenced on November 6 and continued until February 5, during which time 770,440 eggs were collected from 984 fish, 620 males being used to fertilize them. Of these eggs 245,000 were assigned to State fish commissions, foreign societies, and private applicants; 52,000 were transferred to other stations of the Commission; and from the balance 365,000 healthy fry were hatched. During March and April 120,000 of these were distributed to applicants in Virginia and Tennessee; the remainder were placed in troughs in the hatchery and in outside ponds to be reared for the fall distribution, the losses to the close of the fiscal year amounting to 63,038.

During the early stages of the existence of the fry their diet consisted entirely of canned herring roe and salted cod roe, but from May 1 to the close of the year a mixture of liver and mush was given to them. After an experience of two years, fish roe, either salted or canned, is considered far superior to the usual liver diet for small fry. Of the two preparations the canned roe is preferable.

There were no unusual casualties until June 23, when the water supply to one of the ponds was obstructed for several hours, resulting in the loss of 327 two-year old fish.

Quinnat salmon.—On December 31, 5,000 quinnat salmon eggs were received. They hatched between January 8 and 12 with slight loss, and on May 28, when the fry were transferred to the ponds, the loss from the time of hatching amounted to less than 200. They grew very rapidly after being released in the ponds, and at the close of the year were about 4 inches long.

Black bass.—To increase the output of the station, 59 adult small-mouth black bass were transferred from Put-in Bay in October. They were kept in one of the spring-fed ponds until April 14 when they were transferred to the spawning-ponds, which had been prepared with artificial nests. Owing to the unusually cool and cloudy weather they did not commence nesting until late in May, and at the end of June only two nests containing eggs had been found.

Rock bass.—Early in April 145 adult rock bass were placed in the spawning-ponds. These were also affected by cool weather, and though they commenced nesting early in May very few eggs were noticed at the close of the year.

Crappie.—Of 104 crappie transferred from Quincy Station in October, there remained but 46 the following spring. These were in excellent condition, apparently, but so far they have shown no indications of spawning.

PUT-IN BAY STATION, OHIO (J. J. STRANAHAN, SUPERINTENDENT).

The following important improvements were made at the station during the year: A frame storehouse 15 by 20 feet, 1½ stories high, was erected on the southwest corner of the station grounds; the old dock was replanked throughout and supplied with new timbers where needed; a rowboat dock, 40 feet by 9 feet, was built at the southeast corner of the building, running parallel to and 20 feet away from the main dock; a 30-foot channel, 260 feet long and 7½ feet deep, was dredged from the dock outward to deep water; retaining walls were built on the north and the west sides of the main building and on the northeast of the grounds on the lake front; the grounds were graded and seeded and walks were built; a 60-light gas plant was installed in the hatchery, and to obviate the possibility of the water supply being cut off, the suction pipe at the end of the dock was placed in deep water in the new channel.

During October the usual arrangements were made for collecting whitefish and herring eggs at various points on Lake Erie, but owing to the exceedingly bad weather during the spawning season the total take was less than half that of the previous year.

The first eggs were obtained on November 4, but a violent storm commenced November 6 and lasted for several days, causing great destruction to the nets, and breaking up and driving the schools of whitefish and herring out into deep water. Scarcely a pound net escaped injury, and it was estimated that over one-third of the gill nets in the western end of the lake were destroyed; 21 pounds belonging to a firm in Toledo were so injured that they were not fished again during the season.

At the close of operations, on November 26, the total collections amounted to 86,139,000 whitefish and 11,725,000 lake-herring eggs, secured from the following fields:

Collecting field.	Whitefish.	Herring.
Port Clinton.....	45,513,000	5,225,000
Put-in Bay.....	12,218,000	3,200,000
North Bass Island.....	12,159,000	1,100,000
Toledo.....	7,137,000	2,200,000
Kelly Island.....	4,617,000
Middle Bass Island.....	2,439,000
Catawba Island.....	2,061,000
Total.....	86,139,000	11,725,000

Owing to the unfavorable conditions under which the eggs were collected, their quality was not so good as in former years. The first fry were planted on March 26, and deposits were continued to April 29, during which time 60,309,000 whitefish, and 7,299,000 lake herring were liberated.

For the purpose of experiment, 2,000,000 fry hatched early in April were held in four tanks and were fed on fine middlings prepared by

LIV REPORT OF COMMISSIONER OF FISH AND FISHERIES.

the roller process. They commenced to take food on April 8, and were apparently healthy and vigorous until April 17, when a considerable number of dead ones were discovered at the bottom of the tanks. The death rate continued to increase from this time until about the 28th, when it had become so large that it was decided to plant half of them. The balance were held for experimental purposes, and various kinds of food were tried, but they all died on the night of May 6.

The temperature of the water during this period was as follows:

Date.	Air.			Water.			Date.	Air.			Water.		
	Max.	Min.	Mean.	Max.	Min.	Mean.		Max.	Min.	Mean.	Max.	Min.	Mean.
Apr. 8	43	41.5	42.25	40.5	40	40.25	Apr. 23	73	64	68.5	46	45	45.5
9	35	34	34.5	40	40	40	24	74	59	66.5	48	47	47.5
10	41	33	37	40	39	39.5	25	61	54.5	57.75	48	48	48
11	38	35	36.5	40	40	40	26	54	54	54	48	47.5	47.75
12	44	38	41	41	40	40.5	27	44.5	40	42.25	47.5	47	47.25
13	50	49	54	41	40.5	40.75	28	59.5	53.5	56.5	48	48	48
14	49	42	45.5	42	41.5	41.75	29	54	51	52.5	48	48	48
15	52	45	48.5	42.5	42	41.75	30	48	48	48	49	47.5	48.25
16	48	44	46	42.5	42	42.25	May 1	41	41	41	48.5	48.5	48.5
17	37.5	37	37.25	43.5	43	43.25	2	42	40	41	48	47.5	47.5
18	58	40	49	43	42	42.5	3	56	47	51.5	48	47.5	47.75
19	36	34	35	43	43	43	4	55	47	51	51.5	51	51.25
20	33	29	31	43	42.5	42.75	5	56	52	54	52	51	51.5
21	50	41	45.5	43.5	43.5	43.5	6	69	57	63	52	51	51.5
22	72	57.5	64.75	44	43.5	43.75							

From a consignment of 1,000,000 lake-trout eggs shipped from Northville Station 794,000 fry were hatched and liberated in the vicinity of the station, on North Bass Island and Peach Point Reef.

Another attempt was made to collect black-bass eggs by setting out artificial nests in the vicinity of the hatchery. Over 100 were prepared and placed in shallow places, but owing to the very high winds and low temperature prevailing during the spawning season only three broods of young fish were hatched.

In the spring the superintendent made an investigation of the sturgeon fisheries at the west end of the bay, with the view to taking up the propagation of that species, but it was found that the conditions would not warrant it.

Following is a record of the maximum, mean, and minimum temperatures of air and water, by months:

Month.	Air.			Water.			Month.	Air.			Water.		
	Max.	Min.	Mean.	Max.	Min.	Mean.		Max.	Min.	Mean.	Max.	Min.	Mean.
1896.							1897.						
July	90	60	76.51	74	64	70.60	January...	55	-13	29.56	35.5	32.5	32.84
August	92	65	77.09	80.50	68	73.67	February...	44	6	29.47	34.5	32.5	32.63
September	86	54	65.01	70	56.5	66.25	March.....	56.5	21.5	35.12	38	32.5	33.70
October	67	36	51.48	59	46	51.82	April	74	33	46.51	49	37	42.03
November	66	21	43.05	52.5	38.5	44.30	May	77	40	58.84	62	47.5	55.12
December	51	17	31.85	37	32.5	39.74	June	86	52	68.05	73	56	64.85

NORTHVILLE STATION, MICHIGAN (FRANK N. CLARK, SUPERINTENDENT).

The regular force of the station was employed during the summer in assisting in the various constructions, repairs, and improvements. The stock of fish on hand at the beginning of the year was as follows:

Species.	Calendar year in which fish were hatched.				
	1896.	1895.	1894.	1893.	1892.
Brook trout.....	17,000	90			
Wild brook trout.....				075	215
Von Behr trout.....					230
Loch Leven trout.....				512	85
Black bass.....					20
Total.....	17,000	90		1,187	550

The fish continued to do well until the excavations for the new hatchery were commenced, when it became necessary to cut off a large part of the water supply. This resulted in heavy losses, and by the close of summer there remained on hand only 1,600 yearling fish.

Lake trout.—The collection of eggs on Lake Superior commenced on October 9, and was continued without interruption until November 26, the total take amounting to 12,277,000. Of these, 1,330,000 were obtained in the vicinity of Caribou Island, Lake Superior; 2,174,000 near Alpena, Lake Huron, and the remaining 8,773,000 in Lake Michigan, near Epoufette, Beaver Island, and Charlevoix. The eggs were shipped as usual, on canton-flannel trays incased in wooden boxes, and arrived at the station in excellent condition. During the months of November, December, and January 3,487,000 eyed eggs were transferred to other stations of the Commission, State fish commissions, and private applicants, including one shipment to Germany.

The fry commenced hatching early in January, and the distribution was continued from January 29 to March 21, during which period 50,000 were furnished to private applicants, 1,400,000 were planted in Lake Huron, 1,000,000 in the Straits of Mackinac, 2,350,000 in Lake Michigan, and 480,000 in Pine Lake, Michigan. Over 500,000 were placed in tanks in February and fed, and 400,000 were liberated at Beaver Island, Lake Michigan, on April 28. The balance of the stock was retained for distribution in the fall, and at the close of the year the 141,000 on hand in the rearing ponds and troughs were doing well.

Brook trout.—Very few of the wild brook-trout spawners captured in the Au Sable in 1895 remained this season, as most of them died from lack of water at the time the improvements were being made. Between October 17 and November 25, 81,000 eggs were collected from the stock at the station, and 100,000 eggs were purchased. Excellent results were obtained in hatching, and during March and April 97,500 fry were distributed. Two shipments of eggs were made in December, one consignment of 12,000 being furnished to M. A. Bigelow, Evanston, Ill., and one of 3,000 to Central Station.

Loch Leven trout.—The spawning season commenced October 17 and was continued to November 25, but as the eggs were of very poor quality and the hatchery was crowded, operations were discontinued at that time. From the 129 ripe females handled 130,575 eggs were obtained; from these, 5,000 eggs were transferred to other stations and 15,000 fry were distributed.

Rainbow trout.—The consignment of eggs shipped from Neosho yielded 16,000 fry; 6,500 of these were distributed to applicants in Ohio during the spring, and on June 30 there remained at the station 9,000 healthy fingerlings.

Steelhead trout.—On April 27 a consignment of 41,000 steelhead eggs was received from Fort Gaston Station, and 32,000 of the fry resulting from them were planted in May in streams crossed by the Detroit and Mackinac and the Flint and Père Marquette railroads. The remaining 5,000 were held for rearing.

The following shows the number of fry on hand at the close of the year, the age, and the weight of fish per 1,000:

Species.	Age.	Number.	Weight per 1,000 fish.	
			Pounds.	Pounds.
Brook trout	4 months	15,000	7	105
Lake trout.....	4 months	141,000	4	564
Loch Leven trout.....	3½ months	17,000	3	51
Rainbow trout.....	2½ months	9,000	2½	22½
Steelhead trout.....	1½ months	5,000	1½	7½

ALPENA STATION, MICHIGAN, (FRANK N. CLARK, SUPERINTENDENT).

Early in the summer the superintendent and foreman visited the important fishing centers on Lakes Huron, Michigan, and Superior, and made arrangements for the lake-trout and whitefish work. On September 15 the spawn-takers, under the direction of Mr. George Platts, proceeded to Lake Superior and commenced the collection of trout eggs at Spruce Harbor and Michipicoten Island, Ontario, and at the close of the season there they were transferred to various points on Lakes Michigan and Huron. The first whitefish eggs were received at the station on October 27, having been collected at Scarecrow Island, Lake Huron.

The collections continued until December 14, and a total of 35,800,000 were secured from the following points:

Point of collection.	Number secured.	Point of collection.	Number secured.
Warehouse, Lake Michigan.....	1,300,000	Traverse Bay (tributary), Lake Michigan	600,000
Epoufette, Lake Michigan.....	650,000	Hammond Bay, Lake Huron.....	900,000
Naubinway, Lake Michigan.....	650,000	Rogers City, Mich., Lake Huron.....	800,000
Manistique, Lake Michigan.....	10,000,000	Lixey's Fishery (Oscoda), Lake Huron	300,000
Seulchoix Point, Lake Michigan.....	600,000	Alpena and vicinity	7,000,000
Beaver Island, Lake Michigan.....	10,000,000		
Manitou Island, Lake Michigan.....	3,000,000		

REPORT OF COMMISSIONER OF FISH AND FISHERIES. LVII

The eggs arrived at the station in excellent condition. They commenced hatching on March 28 and 32,000,000 were planted during the months of April and May, as follows:

Waters.	Point of deposit.	Number planted.	Waters.	Point of deposit.	Number planted.
Lake Michigan	North Shore	2,000,000	Lake Huron	Hammond Bay	2,000,000
Do.....	Frankfort	2,500,000	Do.....	Scarceow Island	4,000,000
Do.....	Manistique	4,000,000	Do.....	Miller Point.....	4,000,000
Do.....	Beaver Island	3,000,000	Do.....	East Tawas	2,000,000
Do.....	Straits of Mackinac	2,500,000	Thunder Bay	Whitefish Point	2,000,000
Lake Huron...	North Point.....	4,000,000			

After completing the distribution and placing the station in order, Mr. Downing, the foreman, was detached and ordered to Woods Hole, and Mr. Thayer, fish-culturist, to Northville. The station was placed in charge of a watchman to the close of the year.

QUINCY STATION, ILLINOIS (S. P. BARTLETT, SUPERINTENDENT).

Indications in June seemed favorable for a successful season's work, as the winter had been an open one and the bass and crappie spawned early. Three carloads of fish were distributed between July 6 and 22 to applicants in Minnesota, Dakota, Pennsylvania, Ohio, and Mississippi, but heavy rains occurred on July 25, which stopped all work until September 10, when it was resumed and continued until November.

In addition to the fishes furnished to applicants, collections of breeders were made for the Wytheville and Neosho stations and for the Fish Commission ponds, Washington, D. C. During the year the station furnished for distribution the following adults and yearlings: 32,375 black bass, 3,418 crappie, 1,025 yellow perch, and 1,700 pickerel. In addition to this output, immense numbers of the common fishes, such as yellow perch, catfish, sunfish, and other indigenous species were collected from overflowed lands and returned to the Mississippi and Illinois rivers.

During the winter the boiler-house built the previous year was enlarged, all of the buildings were painted, and the boats and seines were overhauled. Owing to continued high water during the spring no collections of fry were made.

MANCHESTER STATION, IOWA (R. S. JOHNSON, SUPERINTENDENT).

The superintendent assumed charge of the station in January. As the work of construction had not advanced sufficiently during the fall to permit of the collection of trout eggs, consignments of lake and rainbow trout eggs were sent from Northville and Neosho during the winter. All of the fry resulting from them, with the exception of 2,500 of the rainbows, were distributed in the spring. These were reserved to be reared for brood stock. Efforts were made to secure a stock of bass as soon as the ponds were ready, but the first consignment of brood fish received from Quincy developed fungus shortly after their arrival

and died. Fifty adults were then collected from the Maquoketa River and placed in Pond X, but they were captured too late in the season to spawn.

On March 9 unusually high water in the spring branch flooded the lowlands east of the superintendent's residence. The water rose a foot above the floor of the wagon bridge, doing considerable damage to the stone abutments and causing numerous washouts along the pond site. The water supply to the hatchery and ponds was cut off by the washing out of the 14-inch pipe, but the eggs and fry were saved by promptly repairing it. Later in the season considerable work was done with the view to protecting the supply pipe and ponds from damage by future freshets. Owing to changes in the plans and to damage done by the freshet and the cyclone of the previous year, the appropriation for the construction of the station proved inadequate, hence work had to be stopped in the spring, pending an additional appropriation of \$4,200, submitted in the deficiency bill.

DULUTH STATION, MINNESOTA (S. P. WIRES, SUPERINTENDENT).

Early in the summer the usual arrangements were made for collecting lake-trout and whitefish eggs from the waters of Lake Superior. The lake-trout season commenced September 15 and closed November 7, resulting in a collection of 5,874,000 eggs from the following points: Ross Port, Ontario, 2,203,000; St. Ignace Island, Ontario, 800,000; Isle Royale, Mich., 1,701,000; Grand Portage, Minn., 410,000; French River, Minn., 40,000; Bayfield, Wis., 690,000; Pueblo River, Ontario, 30,000. They were transferred to the station and 4,768,000 fry were hatched from them and distributed during April, May, and June.

The whitefish collections commenced at Basswood Lake, Minn., on October 17 and the total take of eggs during the season amounted to 4,200,000. The loss during incubation was very heavy, owing partly to unfavorable weather conditions which prevailed during the collecting season and partly to the fact that it was necessary to transport the eggs long distances over rough roads by wagon from the fishing-grounds to the railroad station. As the result of the season's work 1,990,000 fry were deposited at Grace Harbor, Isle Royale, Michigan, on April 29.

In addition to the collections made by the station force 25,000 brook, 21,450 rainbow, and 100,000 steelhead trout eggs were transferred from other stations to be hatched and distributed from Duluth. The brook-trout eggs yielded 15,400 fry, which were furnished to applicants in Minnesota and North Dakota during May and June. The rainbow eggs were in excellent condition when received, but they proved almost a total loss, probably because of the difference in the temperature of the water at Neosho, where they were eyed, and Duluth. The temperature at Duluth during the hatching period was below 34° F., whereas at Neosho it is 57°. The steelhead eggs produced 75,000 fry, which were deposited during July in tributaries of Lake Superior. A number of specimens of that species have been captured in French and Lester

rivers, Minnesota, which indicates that the plants heretofore made in those streams have been successful.

The station force was occupied as usual during the summer months in overhauling the apparatus and painting the buildings. The low, marshy land at the south of the building was also filled in with gravel and stone, and protected from encroachments of the lake by a crib 198 feet long, 6 feet wide, and 3½ feet deep.

NEOSHO STATION, MISSOURI (WILLIAM F. PAGE, SUPERINTENDENT).

The work of the station was directed by W. F. Page until April 4, when the foreman, L. E. Baldrige, was placed in charge. A special appropriation of \$1,000 having been provided in the deficiency bill for 1896, the money was expended in building an addition to the hatchery 18 feet by 18 feet, similar in style to the main building, and equipped with 6 hatching-troughs. By this change the capacity of the hatchery has been increased over 50 per cent. Bass ponds Nos. 11 and 12 were improved by substituting brick and cement standpipe and kettles in place of old wooden ones, and the wooden outlet flumes were replaced by terra-cotta pipe. The trout pools, formerly constructed of wood, were remodeled and rebuilt with brick walls and concrete flooring.

The regular force was utilized in making various other improvements, including repair and painting of the annex, graveling the walks, miscellaneous repairs to the remainder of the ponds, and the construction of a blind ditch from the cellar of the superintendent's residence to the branch. This ditch was rendered necessary by the frequent flooding of the cellar during the fall and winter after heavy rains.

At the beginning of the fiscal year there were on hand at the station the following fish:

Species.	Calendar year in which fish were hatched.			
	1896.	1895.	1894.	1892 or before.
Rainbow trout.....	87,448	2,000	487	336
Black bass.....	20,000			80
Rock bass.....				82
Strawberry bass.....				46
Tench.....	110			23
Total.....	107,558	2,000	487	547

The fry were held through the summer in troughs and ponds, as heretofore, and distributed during September and October.

Rainbow trout.—The stock of breeders on hand at the opening of the spawning season consisted of 1,700 two-year-old trout derived from eggs shipped from California and 790 fish hatched in 1892 and 1894. The spawning season extended from December 17 to February 11, and resulted in the collection of 578,460 eggs, 509,557 of which were from the old breeders. Only 58 per cent of the eggs from the California fish were fertilized, but this is not surprising, as experience has shown that only about half the eggs taken from very young fish are of value.

The shipments of eggs aggregated 229,125, of which 96,200 were

donated to the Nevada and Wyoming commissions. The balance were transferred to the Duluth, Manchester, Leadville, and Northville stations, and with the exception of one consignment to Duluth they were received in excellent condition. In shipping eggs hay was used for the outside packing around the crates, owing to the scarcity of sphagnum moss in the vicinity of the station. The rest of the season's take were hatched and 27,000 fry were distributed during the month of May; the remainder were retained for distribution in the fall, and at the close of the year they numbered 90,725. A slight epidemic occurred among them in May, but it was checked by the liberal use of salt.

Black bass.—The output of yearling bass in the fall, amounting to 15,660, exceeded that of any previous year by 36 per cent. The fry were reared in troughs and fed on finely grated crawfish collected from the ponds at the station. The brood stock of this species was increased to 134 by the transfer of two consignments from Quincy—one in November and one in March—and on April 6 they were distributed in four of the ponds, which had been provided with gravel for nest-building. On April 20 evidences of nesting were observed, and the first fry appeared May 19. Owing to the unusually cool weather prevailing during the spawning season and to an insufficient amount of natural food in the ponds, the crop of fry at the close of the year is very small.

Rock bass.—The rock bass were also reared in troughs and fed on crawfish through the summer, and the output in the fall amounted to 33,390. Early in the spring artificial nests, similar to those in use at Wytheville, were introduced in the rearing-ponds, but the fish refused to occupy them. On April 20 they commenced nesting in the gravel, within a few feet of the artificial nests, and continued until June.

Crappie and strawberry bass.—As a result of the previous spring's spawning 10,000 young fish were collected from the breeding-ponds early in the fall. They were very small and weak, however, and, though great care was exercised in handling them, the majority died, leaving only 3,129 available for distribution. Experience has shown that the young of this species can not be handled with the same freedom as can the young of the black and rock bass.

On the 30th of August 80 adult crappie were transferred to the station from Quincy, but a number of them died during the winter, and by April only 73 breeders remained. These were placed in the ponds on April 16, and at the close of the year a number of fry were observed, though no nesting or spawning had been noticed among them.

The following table shows the maximum, minimum, and mean temperatures to which the various species were subjected during the year:

Species.	Maxi-	Mini-	Mean.	Remarks.
	mum.	mum.		
	° F.	° F.	° F.	
Rainbow trout.....	78	46	58.2	
Black bass.....	94	38	59.2	Ico in December.
Rock bass.....	82	41	58.2	
Strawberry bass.....	89	46	61	
Tench.....	88	57	70	

The following table shows the air temperatures and the amounts of rain and snow, as recorded by months:

Month.	Mean.	Max.	Min.	Pre- cipita- tion.	Snow.	Month.	Mean.	Max.	Min.	Pre- cipita- tion.	Snow.
1806.						1897.					
July	78.4	94	53	3.61		January	32.9	69	-4	4.20	2
August	79	102	50	2.20		February	31.3	73	11	3.47	Trace.
September	68.9	93	39	4.44		March	51.5	93	22	5.65	
October	57.9	83	29	3.63		April	57.5	81	30	3.58	
November	59.3	77	10	3.70	Trace.	May	62.6	85	32	1.73	
December	41.5	70	12	.44	Trace.	June	73.8	92	41	5.38	

In addition to thousands of pounds of crawfish removed from the ponds, the following enemies of fish were killed: 35 snakes, 18 turtles, 1 egret, 12 kingfishers, 1 grebe, 10 ducks, 2 fishhawks, 7 bitterns, 9 muskrats, 6 water-rats, and 2 water-hens.

SAN MARCOS STATION, TEXAS (JOHN L. LEARY, SUPERINTENDENT).

Work on the ponds was sufficiently advanced to permit of the reception of brood fish in December. From December 12 to March 23 collections of crappie, black bass, and rock bass were secured from the surrounding streams, 200 rock bass being taken from San Marcos River, and 281 large-mouth black bass from the San Marcos and the Blanco River, 3 miles distant. The crappie were obtained from York Creek and from the Colorado River near Austin. Several hundred of these fish were secured; but as it was necessary to haul them over 18 miles of rough road, thence 36 miles by rail, all but 199 of them perished before reaching the station. The muddy state of the water also augmented the loss.

The black bass were placed in three ponds and commenced spawning on February 10, the time when they were seen nesting in the river. Nesting continued at intervals until June 1. Contrary to their habits in the Eastern States, the large-mouth black bass in Texas deposit their eggs on the clay, first sweeping away the moss and weeds with their tails. To thoroughly test this matter, patches of gravel and artificial nests were placed in the ponds, but in no instance were they accepted, and observations disclosed the fact that all of the bass in the San Marcos River deposit their eggs on clay bottom.

As soon as the fry had attained sufficient size they were transferred from the breeding to the rearing ponds by the use of dip nets and of small seines made of mosquito netting. The food furnished consisted of crawfish, the flesh and roe of the mullet, and beef liver finely chopped. An experiment was made in feeding the salted roe of the cod, but it was not readily taken. As they increased in size the fish were fed on such minnows as could be captured in the vicinity; the young of the mud shad seemed to be the most acceptable. With the view to providing a supply of live food an attempt was made to rear young carp. As only a small number could be secured, however, 42 buffalo-fish were substituted, but the results were not successful. Mud shad proved better adapted for

this purpose, and as they are vegetable feeders they can be placed in the nursery ponds to spawn, thus obviating the necessity of transferring the young. In addition to this they give up their eggs freely and can be hatched artificially if necessary.

The heaviest losses from cannibalism occur during the first four weeks of the life of the young bass. This is probably due to an insufficient amount of natural food, such as minute crustaceans and insects, as it is impossible to provide them in adequate quantities where large numbers of fry are confined in a limited area, though they thrive in abundance under natural conditions. As soon as a length of 2 or 3 inches has been attained this difficulty is partially overcome, as they can be readily fed on the fry of other fishes or on chopped food. To show the extent of loss by cannibalism the following illustration is given: 5,000 bass less than an inch long were placed in a pond 16½ feet by 50 feet and given careful attention. In 20 days 90 per cent of them had disappeared. This loss must be ascribed solely to cannibalism, as, the water being perfectly clear, the destruction of the fish by such insects as the boat-fly could not have escaped observation.

The growth of the young bass was very rapid, all of them averaging 3 inches and a number 5 inches in length by May 1; 100 of them, retained until the following October, measured over 8 inches. Their rapid growth and the difficulty of securing a sufficient supply of food rendered it necessary to commence distribution in May, and by the end of June 11,700 had been furnished to applicants in Texas.

The rock bass and crappie have shown no signs of spawning up to the close of the year, and it is doubtful whether any results will be realized from them this season. It is probable that they were transferred too late in the year for spawning.

On June 30 the following fish remained on hand:

Species.	Adults.	Year- lings.	Fry.
Black bass	101	180	12,000
Crappie	99	105	
Rock bass	200		
Carp (scale and mirror)	24	400	
Mud shad	8		
Total	432	685	12,000

During the excavation of the ponds many human and animal bones were unearthed. These were found in heaps in many instances, and when exposed to the air they crumbled to pieces. Many implements of stone were found, but none of metal. The bulk of this material has been forwarded to the U. S. National Museum, Washington, D. C.

The artesian well maintained a steady flow of over 1,000 gallons per minute throughout the year, at a regular temperature of 72°. The minimum temperature of the water in the ponds during the winter was 61°, in summer 76°. The minimum temperature of the air, in January, was 18°; the maximum, in August, was 101°.

REPORT OF COMMISSIONER OF FISH AND FISHERIES. LXIII

LEADVILLE STATION, COLORADO (E. A. TULIAN, SUPERINTENDENT).

At the beginning of the fiscal year the stock of fish on hand was as follows:

Species.	Calendar year in which fish were hatched.		Eggs.
	1896.	1897.	
Brook trout	137,000	566
Loch Leven trout	11,780	118
Rainbow trout	24,500		44,900
Black-spotted trout	29,000	40	57,900
Yellow-finned trout			15,100

The fish were held in the troughs and rearing-ponds until fall, when the following distribution was made: Brook trout, 94,000; Loch Leven trout, 500; black-spotted trout, 42,200; native or yellow-finned trout, 7,931; rainbow trout, 25,500.

Besides caring for the fish on hand, the employees of the station were engaged during the summer in making a number of improvements, embracing the construction of a flume between the middle and lower lakes, installing troughs in the northern half of the hatchery, which had not previously been in use, and making a number of minor repairs to the various cabins and log buildings.

Brook trout.—Prior to the opening of the spawning season arrangements were made as usual with the owners of Uneva, Wellington, Young, and Decker lakes, Gale and Smith ponds, for the collection of eggs on shares. Lower and Middle Evergreen lakes were also drained and the fish belonging to the Commission removed and placed in ponds near the hatchery. The first eggs were obtained from them on October 7 and the last on December 24, the total take aggregating 418,000. The large loss on these during incubation, amounting to 174,000, or nearly 42 per cent, was attributed to the removal of the fish from the lakes to the ponds too early in the season. The eye-spots appeared within 50 days and the first fry hatched at the end of 93 days. The season at Uneva Lake extended from October 21 to December, and resulted in a collection of 186,600, 6 per cent of which were lost in hatching. The spawning season at Gales Pond covered the same period, and 281,900 eggs were secured. The loss during incubation was 34 per cent, which, though large, was smaller than that of the previous year, when the fish were overfed. In addition to this, a spawning-house had been provided, so that the eggs were not subjected to intense cold, as heretofore.

At Smith Pond the collections aggregated 109,700, and the loss in hatching was 11 per cent. At Ridgeway the fish had to be stripped out of doors during very cold weather, and as a result only 74,000 eggs, of very poor quality, were obtained.

The season at Wellington Lake opened November 5 and continued to the middle of December. The difficulties previously encountered at that point were largely overcome by the erection of suitable shelter and the

exercise of great care in the transportation of the eggs over the rough mountain roads from the lake to the railroad station. Only 13 per cent of the 493,700 taken were lost. At Decker Lake 511,500 eggs were taken, but, owing to the fact that the fish were very closely confined in retaining vats during extremely cold weather, 55 per cent of the eggs and 20 per cent of the fry were lost. At the time the last lot of eggs were taken the thermometer registered 20° below zero in the cabin where operations were being conducted; the eggs froze to the pans and the fish died within a few minutes after being handled. The eggs taken at Young Lake yielded 57,615 fry, or 80 per cent of the number collected.

During the winter 190,000 trout eggs were shipped to the various State fish commissions, private individuals, and stations of the United States Commission. The balance were hatched, and on May 1 there were at the station 1,021,200 fry, 479,000 of which belonged to private parties. Owing to very cold weather throughout the spring, they did not commence taking food until they were about 80 days old.

In order to make room for the eggs of the rainbow, black-spotted, and yellow-finned trout, 287,000 of the fish belonging to the Commission were distributed in May and June to applicants in Colorado. The losses during this period amounted to less than 2½ per cent, and at the close of the year there were 241,465 on hand.

Rainbow trout.—The stock on hand at the beginning of the year was derived from collections made at Twin and Uneva lakes during the previous spring, and in September, when the fish were distributed, the output amounted to 25,500. In February a consignment of 44,000 eggs was received from Neosho. The loss during incubation was only 10 per cent, but the fry were very weak and such large numbers of them died during the sac stage that there were only 2,000 available for distribution in the spring. Collections of eggs were again made at Twin and Uneva lakes in May and June, 54,000 being secured from both sources. The spawning season opened on May 10, and the eggs commenced hatching in 27 days, the eye-spots appearing in 13 days. The losses during incubation amounted to 27 per cent, and at the close of the year there were 25,370 fish and 8,000 eggs on hand.

Yellow-finned trout.—When the general distribution was made in September the output of the species amounted to 7,931. Collections of eggs were made during the following May at Twin Lakes, and as a result there were 8,480 fry on hand at the close of the year. The losses during incubation amounted to 3,920.

Black-spotted trout.—The use of the State trap and hatchery at Twin Lakes having been tendered the Commission by the State authorities, arrangements were made to conduct operations there on a larger scale than heretofore, but as it was necessary to keep a man on watch constantly to prevent the theft of the fish and the destruction of the trap, the results were not commensurate with the expense involved, though they were better than in previous years. A collection of 167,000 eggs was made at Freeman Lake in June, and 5,200 were secured from the

fish at the station. These, with the take at Twin Lakes, made an aggregate of 498,900. A consignment of 5,000 of these eggs was sent to Nashville in June and arrived in excellent condition, only 9 of them being dead when unpacked. They were hatched at the exposition during July with comparatively no loss. The losses on the balance of the stock amounted to 39,300, or nearly 8 per cent, and on June 30 there were 164,780 fry and 289,820 eggs on hand. In view of the poor results attained at Twin Lakes this year it has been decided to depend on Freeman Lake and on such collections as can be made from the stock at the station, for the supply of black-spotted eggs in future.

. BOZEMAN STATION, MONTANA (JAMES A. HENSHALL, SUPERINTENDENT).

This station is located on Bridger Creek, in the Gallatin Valley, and is 3½ miles from the city of Bozeman. Its water supply is obtained from two springs, the combined volume of which varies from 1,200 gallons in wet weather to 500 in the dry season; the temperature of the water is 45°, and it is always clear. The superintendent, James A. Henshall, was appointed on the 1st of January and reported for duty on the 11th of that month.

During the winter 25,000 brook trout eggs were received from Leadville and 100,000 steelhead eggs from Fort Gaston. The fry resulting from them were transferred to the rearing-ponds in April and May, and at the close of the fiscal year the brook trout numbered 14,111 and the steelheads 84,858. Besides caring for the eggs and fry, the station force was employed during the winter and spring in completing the roadways, repairing damage done to the ponds by frost, grading around the buildings, and other miscellaneous work.

In the spring arrangements were made to collect eggs from wild black-spotted trout, which were said to spawn during June and July. From information gathered from residents in the locality it was believed that large numbers could be secured at Mystic Lake (about 16 miles from Bozeman, in the mountains), but owing to the impassable condition of the roads the superintendent was delayed until June 12 in making the inspection. This lake is 30 acres in area, has a depth of 100 feet, and is fed by two ideal spawning-streams with gravelly bottoms. Numbers of spawning-beds were found, and it was decided to return at once with the necessary outfit. Owing to heavy rains, however, the return trip was not made until June 17, when it was found that the spawning-beds had been flooded through the raising of a dam by an irrigating company. A few fish were taken in the small holes near the outlet of the lake, and 10,000 eggs were secured.

As trout were reported to occur in great numbers in Soda Butte Lake, in the northwestern section of the Yellowstone Park, an effort was made to collect eggs there in July, but none were obtained, as it was found that the fish there, as in Mystic Lake and other waters in the vicinity, spawn much earlier than has been commonly believed. It is thought that large numbers of eggs can be obtained at both these

LXVI REPORT OF COMMISSIONER OF FISH AND FISHERIES.

points in future, but it will be necessary to construct temporary hatcheries, so that eggs may be eyed before being transferred to the station.

BAIRD STATION, CALIFORNIA (LIVINGSTON STONE, SUPERINTENDENT).

Early in July the rack to prevent the ascent of the salmon was completed and a wagon and foot bridge was built across the river. A new current-wheel, spawning-house, salmon corrals, etc., were constructed by the station force.

The first ripe salmon were captured on August 21, and eggs were taken daily from that time to September 16, the total collection aggregating 5,000,000. These were held until the eye-spots appeared, when they were shipped to the State hatchery at Sisson, Cal. The last of them were disposed of by October 20, and as it had been decided not to make collections from the late run of salmon arrangements were made for the transfer of a large part of the equipment and the force to Battle Creek Station. During December over 2,000,000 salmon eggs were forwarded to Baird from that station, to be hatched and liberated in McCloud River. To prevent the crowding of the troughs, 1,000,000 of the fry were liberated in January; the remainder were divided into four lots and experiments were tried for the purpose of determining what preparation of food would produce the best results. The first lot was fed on liver exclusively, the second on a mixture composed of three parts liver to one of mush, the third on equal parts of mush and liver, and the fourth on three parts mush to one of liver. The fish fed on liver exclusively were found to exhibit a marked superiority in size and strength over those fed on the mixtures, but there was very little difference in the condition of the three lots fed on liver and mush in varying proportions.

Early in June the work of commencing a new rack and bridge for the coming season was undertaken, and the indications point to a very large run of salmon.

The following tables show the daily take of salmon, the daily collection of eggs, and the maximum, minimum, and mean temperatures of air and water, by months:

Date.	No. of eggs taken.	No. of males taken.	No. of females taken.	Ripe females.	Date.	No. of eggs taken.	No. of males taken.	No. of females taken.	Ripe females.
1897.					1897.				
Aug. 22	-----	204	75	36	Sept. 6	277,500	62	68	54
23	184,000	107	109	29	7	221,000	73	72	58
24	81,000	162	98	33	8	211,900	56	63	46
25	320,000	158	102	24	9	212,100	61	52	43
26	120,100	123	66	13	10	198,700	75	74	43
27	50,400	106	70	17	11	182,000	50	76	46
28	144,650	185	107	35	12	171,350	26	33	20
29	227,550	253	176	52	14	160,325	43	54	41
30	154,300	156	72	10	15	125,075	13	18	15
31	185,200	258	138	40	16	144,900	22	31	14
Sept. 1	198,200	166	98	56	17	-----	24	27	24
2	318,950	153	120	70	18	-----	3	5	5
3	351,700	141	135	70	20	183,000	-----	-----	-----
4	445,000	134	131	96	Total..	5,106,700	2,989	2,170	1,063
5	377,400	115	83	66					

REPORT OF COMMISSIONER OF FISH AND FISHERIES. LXVII

Temperatures.

1896.	Air.			Water.			1897.	Air.			Water.		
	Max.	Min.	Mean	Max.	Min.	Mean		Max.	Min.	Mean	Max.	Min.	Mean
July	99	53	66.9	60	55	58	January ..	69	24	44	47	42	44.6
August	96	50	74.8	58	53	56.5	February ..	71	26	44.3	49	41	45.4
September ..	94	45	68.6	58	48	53.3	March	62	22	44.4	49	41	42.2
October	91	38	60.6	54	45	50.4	April	85	29	58.9	52	45	50.1
November ..	62	24	47.8	52	41	46.1	May	96	45	67.8	57	49	53.3
December ..	71	32	46.3	49	43	44	June	94	43	64.1	59	50	56.2

BATTLE CREEK STATION, CALIFORNIA (JOHN P. BABCOCK IN CHARGE).

Recognizing the necessity for increasing the output of quinnat salmon on the Pacific Coast, the Commissioner arranged to erect a hatchery on lands controlled by the California Commission on Battle Creek; also to take charge of and operate the hatchery erected by the State commission the previous year, in accordance with the following agreement:

This agreement, made this 20th day of October, A. D. 1896, by and between J. J. Brice, of Washington, D. C., acting for and in behalf of the United States Commission of Fish and Fisheries, of the first part, and H. F. Emeric, of San Francisco, Cal., acting for and in behalf of the Board of Fish Commissioners of the State of California, of the second part, witnesseth:

That the said party of the second part does hereby agree to take charge of and assume the entire control and management, under the personal supervision of Chief Deputy Babcock, of the spawning station located on the land of F. R. Love, at Battle Creek, State of California; and, in the name of the United States Commission of Fish and Fisheries, operate the hatcheries at said Battle Creek to their fullest capacity.

The said party of the first part does hereby agree to pay all the operating expenses, including the salaries and wages of all men employed, from October 1, 1896, until the close of the season's operations at said Battle Creek.

The said party of the first part also agrees to deliver to the said party of the second part that amount of eyed salmon spawn which the said party of the second part may be able to hatch at the Sisson hatchery.

The hatchery built by the United States Fish Commission has a capacity for about 18,000,000 eggs, and is a one-story frame building, 144 feet long by 40 feet wide, lighted by skylights in the roof and shuttered windows in the sides and ends. It contains two distributing-troughs and 92 hatching-troughs, one-half of which are 16 feet long by 16 inches wide and 6½ inches deep and the other half 16 feet long by 12 inches wide and 6½ inches deep. The troughs are arranged in sections of four, securely bound together, two of them abutting against the distributing boxes, from which they take their supply of water and carry it to the two below. At the head of each hatching-box is a tin aerator, 10 inches by 4½ inches, with perforated bottom. Each trough has a capacity for 200,000 eggs, and the supply of water admitted to each is 24 gallons per minute.

Mr. J. P. Babcock, of the California Commission, was placed in charge of the work, and arrangements were made to operate the station to its fullest capacity. The first eggs were taken October 20 and the collection continued till November 23, when the retaining-racks were carried

With the view to testing the advantages to be derived from planting fry near the ocean, arrangements were made for hatching 750,000 of the eggs collected at the State experimental station at Olema, Cal. They were shipped on December 31, and the resulting fry were planted during February and March in Dutch Bill, Boccacio, Olema, and Bear Valley creeks. Their movements were carefully noticed by Messrs. A. B. Alexander and N. B. Scofield.

CLACKAMAS STATION, OREGON (W. F. HUBBARD, SUPERINTENDENT).

The superintendent was occupied during a portion of the summer in examining a number of tributaries of the Columbia River, with the view to establishing auxiliary stations, to be operated in connection with the station on the Clackamas. As a result of his investigations, arrangements were made for the collection of eggs on the Salmon River, a tributary of the Sandy, and on the Little White Salmon, emptying into the Columbia above the Cascades, in the State of Washington. The collections on the Snake and Sandy rivers the previous year were so small that it was decided not to operate at those points again.

Early in July the station force commenced the construction of a rack 330 feet long across the Clackamas River. Great difficulty was experienced in this undertaking on account of the extensive rafting of logs and wood from points above, but arrangements were finally made with the lumbermen to provide a boom, and a gate was built in the rack to permit of the passage of the material. The rack was completed on July 18, and the force was utilized during the remainder of the summer in making repairs to the boats and fishing apparatus, building a trap for the capture of spawning fish, and laying a new floor in the hatchery. The collection of eggs from the fish below the rack was commenced on September 11, and operations were continued until October 31, the total take amounting to 1,062,500. On that date a part of the rack was carried away by a rise in the river, and, as it was late in the season and there appeared to be very few fish below the rack, no attempt was made to repair it.

The results of the season's work were very discouraging, as the traps and seines had been worked night and day, and gill nets had also been fished on the riffles below, where a few salmon were observed spawning.

Early in November the volume of the spring brook was so increased by heavy rains that the pumps were discontinued and the supply for the hatchery taken from that source. Considerable damage was done to the station during the month by high water. The bridge across Clear Creek was carried away on the night of November 8, and on the 13th the river rose 13 feet above its normal level, carrying away the plank breakwater built in 1877, covering and greatly damaging the land about the station, and flooding the hatchery so that a boat could be brought into the door.

Shipments of eggs aggregating 2,340,000 were received from the Salmon River station between September 11 and October 6. The fry

resulting from them appeared strong and healthy until they were about two weeks old, when a large number of them were affected by a disease which had never occurred at the station before. Its first indication was the appearance of a small white spot on the yolk-sac, followed by an unnatural position of the fish in swimming, the body being held perpendicular with the head near the surface of the water. As soon as death resulted the yolk-sac would burst. All the fish affected in this way were liberated as soon as possible.

About the middle of December a consignment of 3,000,000 salmon eggs was transferred from Battle Creek, California, being shipped by rail to Oregon City and thence to the station by wagon. The eggs arrived in excellent condition, and by January 25 they had finished hatching. All but 500,000 of the fry were liberated, just before the absorption of the sac, in Clear Creek and on the natural spawning-grounds of the salmon in the Clackamas River, within a range of 2 miles up and down stream. Those retained at the station were fed on finely chopped beef liver and on chopped fish when liver could not be obtained. The rate of growth was rapid. On March 10 the total weight of 1,000 of them was $1\frac{1}{2}$ pounds, and on May 31, when the last of them were planted, the weight of the same number was 3 pounds. They were liberated in small lots from time to time during the month of May, and the total loss on the 500,000 retained amounted to 11,400.

The only serious loss in addition to the mortality resulting from the disease referred to above occurred on November 26. There were in the hatchery at that time 600,000 fry in excellent condition when the watchman left the building at 5 p. m. On the arrival of the superintendent two hours later all of them were dead. As no one had access to the building and as the water supply was in free operation it was evident that some poisonous substance had been introduced into the water before it entered the hatchery, by some ill-disposed person.

Specimens of the dead fish examined by a chemist in Portland showed the presence of lime and salt. Salt, except in large quantities, is not injurious to fry, but experiments by the superintendent proved that young salmon in flowing water can be killed in a very short time by the introduction of limewater or small pieces of fresh lime.

During the spring the wagon bridge across Clear Creek was rebuilt, and the mess-house and fences, which had been damaged by high water during the previous winter, were repaired.

SALMON RIVER STATION.

The site selected for the establishment of the auxiliary station was on a small island in the middle of the Salmon River, about 35 miles from Clackamas Station by wagon road. As the salmon spawn in that river much earlier than in the Clackamas, the rack was put in during the latter part of June and arrangements were made with Mr. J. J. Pankey to furnish ripe salmon at 50 cents each. Immediately after the completion of the rack an open shed was erected, the necessary

troughs were provided, the trap was built below the rack for the capture of the fish, and a flume was laid from a small brook near by, from which the water supply was obtained by gravity. Salmon appeared in large numbers in July, and a few were observed spawning the latter part of the month. The first eggs were obtained on August 11, and the collections were continued until September 12, during which time 2,600,000 were secured from 492 females; 2,340,000 of them were transferred to Clackamas, and the remainder were hatched and liberated in the Salmon River during the month of November. The supply of water failed during the season, and it became necessary to place part of the hatching-troughs in a narrow channel, where they were supplied with water conducted through a short flume from the bottom of the river. Wooden covers were provided for each trough to protect the eggs, and canvas, stretched on poles, shaded them from sunlight. The heavy rains in November caused a freshet in the river, which necessitated the removal of the hatching apparatus to higher ground.

LITTLE WHITE SALMON RIVER STATION, WASHINGTON.

After the examination of a number of localities on the Columbia and its tributaries by Prof. B. W. Evermann, two sites were recommended for establishment of auxiliary stations, one on the Washington shore of the Columbia opposite the Cascades, and the other just below Celilo, on the Oregon side. At the Cascades Mr. George Stevenson, of Vancouver, offered to furnish all the fish required free of charge, with the free use of the land and water controlled by him, and a house for the employees. It was proposed to capture the fish by means of scow wheels and hold them until ripe in a narrow channel between the island on which the wheels are located and the main shore. The superintendent was instructed to make the necessary arrangements, but before undertaking the work an attempt was made to transfer the fish from the wheels to the channel. The results attained were so poor that the site was abandoned. The question of establishing a station at the other site, near Celilo, was also considered, but it was given up as impracticable, in view of the fact that it would be necessary to transfer the fish some distance from the seines to the retaining pond.

As it was believed that the streams in the vicinity of the Cascades afforded the principal spawning-grounds of the quinnat salmon, further investigations were made, and as a result the Little White Salmon was favorably reported on by the superintendent and Mr. Evermann. This stream empties into the Columbia about 14 miles above the Cascades, and the point selected for the establishment of the station is about a half mile from its mouth. Immediately after the site had been chosen, steps were taken to erect a rack across the river and to construct a hatchery and a mess-house for the men. Mr. W. P. Sauerhoff, who had been detailed to assist the superintendent, arrived on the grounds by September 21, and by September 26 work had progressed far enough to commence the collection of eggs. Eggs were taken daily

from that time to October 14, a total of 2,179,000 being secured from the 427 females handled. During the season the salmon appeared in such large numbers below the rack that the Indians often captured two and three at one cast of the spear; many were also observed above the rack, having ascended before it was constructed.

In view of the fact that the work of construction at this point was not undertaken until September 15, when the spawning season had already commenced, the results secured were considered excellent. Had the station been established earlier in the season, there seems little doubt but that seven or eight million eggs might have been collected. The lands on which the station is located are owned by an Indian, Joe Thomas, and steps are now being taken by the Government to lease it. The total cost of operating at this point, including construction of hatchery and outbuildings, amounted to \$2,288.27. The hatchery was a rough wooden structure without a floor, lighted by skylights above and unglazed windows in the sides and ends. It was equipped with 50 troughs, and the water supply was obtained from a brook a short distance away. The other buildings consisted of sleeping quarters and a mess-house for the employees. At the close of the collecting season the trough room was found to be insufficient, and additional troughs were erected outside for holding the fry.

Owing to heavy rains on November 15, the water in the brook from which the supply was obtained became so muddy that it was necessary to discontinue using it and to take the supply from the lumber company's flume. During this time the men were obliged to work night and day to keep the screens open and a supply of water flowing through the troughs. Snow commenced falling early in November, and by the 28th the thermometer had fallen to 13° above zero.

Mr. Sauerhoff was detached from the station on January 18 and J. A. Tolbert left in charge. The fry were all liberated between January 7 and February 15 in the Little White Salmon near Chenowith, Wash. At the close of the season the apparatus was stored in the bunk-house, and, as the grounds on which the station is located are liable to floods, the hatchery was weighted down with stone and placed in charge of a watchman, who was permitted to occupy the mess-house.

SIUSLAW RIVER STATION, OREGON (L. E. BEAN IN CHARGE).

Upon the recommendation of Dr. S. E. Meek, who was engaged in investigating the salmon streams in western Oregon, the Commissioner authorized the reopening of the hatchery on the Siuslaw River at Mapleton on a small scale. The owner tendered its use to the Commission without rental, and the fishermen agreed to furnish the necessary adult salmon on the fishing-grounds, about 26 miles below Mapleton, free of expense. An effort had been made to operate this station in 1895, but no results were secured, as the fish were all captured several miles below the rack by seines and gill nets. This season it was deter-

mined to transfer a stock of brood fish in live-boxes from the seining-grounds and hold them at the hatchery until they ripened. Several hundred salmon were collected at the seines and floated up to the station in this way, and from them 44 ripe females and 42 ripe males were saved. Between October 26 and November 16, 217,000 eggs were secured from these fish, and during the month of February plants of fry aggregating 180,000 were made on the spawning-grounds in the immediate vicinity of the station. The fry were observed from time to time during the spring by Mr. Bean, and numbers of small schools could be seen in the creeks where the deposits had been made as late as May. They appeared to be from 1 to 1½ inches long—not quite as large as a few which had been retained at the hatchery and fed. Observations were continued throughout the spring, but in June all of the fry disappeared from the upper parts of the creeks, and were apparently moving toward the mouth of the river.

FORT GASTON STATION, CALIFORNIA (CAPT. W. E. DOUGHERTY, SUPERINTENDENT).

This station was operated, as usual, for the collection of eggs of the chinook and silver salmon and the steelhead trout. A rack was constructed in Redwood Creek, and the first eggs were obtained on December 17. As a result of the season's work, 406,000 eggs of the chinook and silver salmon were secured, from which 405,000 fry were hatched and liberated in Redwood Creek during April and May. The spawning season of the steelhead trout commenced on February 7 and continued until April, 805,000 eggs having been secured from 179 brood fish. Of these, shipments aggregating 550,000 were sent to Bozeman, Craig Brook, Cape Vincent, St. Johnsbury, Northville, and Duluth stations, and one consignment of 50,000 was furnished to the New York Fish Commission. From the remainder of the collection 202,000 fry were hatched and liberated in Redwood Creek in June.

Owing to the increased demand for steelhead trout eggs in the East, the Korbelt Station, which had been closed the preceding year, was reopened. The results attained at this point were very unsatisfactory, as work was seriously interfered with at the very height of the spawning season by high water, which did considerable damage to dams and racks. From the eggs collected 337,600 salmon and 55,640 steelhead trout fry were hatched and liberated in the Mad River during the month of June.

LXXIV REPORT OF COMMISSIONER OF FISH AND FISHERIES.

Résumé, by States and Territories, of the distribution and assignment of fish and eggs.

State or Territory.	Species.	Eggs.	Fry.	Adults and yearlings.
Alabama.....	Rainbow trout.....			2,190
	Black bass, large-mouth.....			680
	Rock bass.....			975
Arizona.....	Rock bass.....			300
Arkansas.....	Rainbow trout.....			11,750
	Brook trout.....	5,000		
California.....	Black bass, large-mouth.....			350
	Rock bass.....			650
	Quinnat salmon.....	17,982,500	3,056,701	
	Ladlocked salmon.....	10,000		
	Silver salmon.....		298,137	
	Steelhead trout.....		257,000	
	Loch Leven trout.....	20,000		
	Rainbow trout.....		22,000	30,000
Colorado.....	Von Behr trout.....		22,100	275
	Lake trout.....	125,000		
	Loch Leven trout.....			500
	Rainbow trout.....		14,000	
	Black-spotted trout.....		42,200	
	Brook trout.....		288,700	53,200
	Yellow-fin trout.....		7,830	
Connecticut.....	Rock bass.....			200
	Shad.....		5,480,000	
	Atlantic salmon.....	100,000		
	Rainbow trout.....	50,000		
	Brook trout.....	25,000	204,168	
Delaware.....	Lake trout.....	100,000		
	Lobster.....		2,234,000	
	Shad.....		9,850,000	
District of Columbia.....	Rainbow trout.....			1,000
	Shad.....		4,025,000	1,500,000
	Rainbow trout.....		7,479	200
Florida.....	Black bass, large-mouth.....			2,500
Georgia.....	Shad.....		2,017,500	
	Shad.....		2,400,000	
	Rainbow trout.....		10,000	3,425
Idaho.....	Black bass, large-mouth.....			1,510
	Rock bass.....			2,300
	Rainbow trout.....		1,500	
	Brook trout.....	5,000		7,500
Illinois.....	Loch Leven trout.....	2,000		
	Brook trout.....	12,000	1,000	
	Lake trout.....	2,000		
	Yellow perch.....			1,025
	Pickereel.....			1,700
	Black bass, large-mouth.....			3,280
	Crappie.....			275
	Rock bass.....			100
	Black bass, large-mouth.....			4,400
	Crappie.....			1,800
Indiana.....	Rock bass.....			65
	Rainbow trout.....			7,073
	Rock bass.....			300
Iowa.....	Rainbow trout.....		41,222	
	Brook trout.....		14,700	
	Lake trout.....		158,000	
	Black bass, large-mouth.....			3,716
	Crappie.....			125
Kansas.....	Rock bass.....			1,000
	Rainbow trout.....			6,200
	Black bass, large-mouth.....			5,825
	Crappie.....			1,750
Kentucky.....	Rock bass.....			6,525
	Rainbow trout.....			895
	Black bass, large-mouth.....			5,585
	Rock bass.....			1,535
Maine.....	Quinnat salmon.....	30,000	1,810,936	7,198
	Atlantic salmon.....	40,000	1,055,071	234,790
	Ladlocked salmon.....	20,000	61,050	11,050
	Steelhead trout.....		55,745	10,545
	Rainbow trout.....			7,402
	Von Behr trout.....			569
	Brook trout.....	30,000	50,000	519
	Lake trout.....			3,211
	Swiss lake trout.....			18,982
	Golden trout.....	10,000	35,000	
Maryland.....	Black bass, large-mouth.....			500
	Lobster.....		15,389,360	
	Shad.....		30,586,000	
	Quinnat salmon.....		7,516	
	Loch Leven trout.....		2,209	

REPORT OF COMMISSIONER OF FISH AND FISHERIES. LXXV

Résumé of the distribution and assignment of fish and eggs—Continued.

State or Territory.	Species.	Eggs.	Fry.	Adults and yearlings.
Maryland.....	Rainbow trout.....			2, 234
	Brook trout.....		2, 202	25
	Lake trout.....		4, 338	
	Striped bass.....		450, 000	
	Black bass, large mouth.....			3, 300
Massachusetts.....	Rock bass.....			950
	Shad.....		450, 000	
	Atlantic salmon.....	25, 000		
	Rainbow trout.....			500
	Brook trout.....		25, 600	
	Lake trout.....			6, 200
	Black bass, large-mouth.....			3, 000
	Black bass, small-mouth.....			1, 800
	Codfish.....		98, 258, 000	
	Flatfish.....		64, 095, 000	
	Lobster.....		95, 418, 705	
Michigan.....	Tautog.....		624, 000	
	Mackerel.....		652, 000	
	Sea bass.....		193, 000	
	Landlocked salmon.....	5, 000		
	Steelhead trout.....		32, 000	
	Loch Leven trout.....		15, 000	
	Brook trout.....		21, 500	
	Lake trout.....		5, 743, 000	
	Whitefish.....		33, 990, 000	
	Steelhead trout.....		64, 000	
Minnesota.....	Rainbow trout.....		200	
	Brook trout.....	25, 000	7, 400	
	Lake trout.....		1, 408, 000	
	Black bass, large-mouth.....			400
Mississippi.....	Rainbow trout.....			500
	Black bass, large-mouth.....			658
	Crappie.....			50
Missouri.....	Rock bass.....			2, 142
	Rainbow trout.....		27, 000	15, 655
	Black bass, large-mouth.....			1, 710
	Crappie.....			500
Montana.....	Rock bass.....			2, 050
	Strawberry bass.....			120
	Rainbow trout.....		1, 500	
Nebraska.....	Brook trout.....			5, 500
	Lake trout.....	25, 000		1, 000
	Black bass, large-mouth.....	200, 000		
	Rock bass.....			700
Nevada.....	Rainbow trout.....			1, 000
New Hampshire.....	Quinnat salmon.....	50, 375		
	Landlocked salmon.....		49, 000	
	Steelhead trout.....		10, 000	
	Rainbow trout.....			1, 000
	Brook trout.....	50, 000		
New Jersey.....	Shad.....	10, 000	20, 000	
	Steelhead trout.....	2, 819, 000	26, 609, 000	
	Rainbow trout.....		3, 000	
	Brook trout.....	25, 000	2, 000	2, 840
	Black bass, large-mouth.....	10, 000		
	Rock bass.....			2, 100
	Landlocked salmon.....	3, 000		180
	Rainbow trout.....			3, 252
	Black bass, large-mouth.....			150
	New York.....	Shad.....		8, 925, 000
Quinnat salmon.....			1, 950, 000	
Atlantic salmon.....		125, 000	48, 000	
Landlocked salmon.....		18, 000		
Steelhead trout.....		50, 000	7, 300	100
Rainbow trout.....			16, 000	1, 000
Brook trout.....		25, 000		500
Lake trout.....		400, 000	1, 290, 000	
Swiss lake trout.....				11, 100
Whitefish.....			750, 000	
Black bass, large-mouth.....				600
Rock bass.....				180
Shad.....			17, 861, 000	
Rainbow trout.....			14, 000	6, 815
Black bass, large-mouth.....			5, 300	
Rock bass.....			1, 500	
North Dakota.....	Brook trout.....		8, 000	
	Rainbow trout.....		6, 500	
Ohio.....	Brook trout.....	15, 000	8, 000	
	Rainbow trout.....		794, 400	
	Lake trout.....			60, 300, 000
	Whitefish.....			

LXXVI REPORT OF COMMISSIONER OF FISH AND FISHERIES.

Résumé of the distribution and assignment of fish and eggs—Continued.

State or Territory.	Species.	Eggs.	Fry.	Adults and yearlings.
Ohio	Lake herring		7,299,000	
	Black bass, large-mouth			3,055
	Black bass, small-mouth			31
Oklahoma	Rock bass			950
	Rainbow trout			8,541
	Black bass, large-mouth			200
Oregon	Rock bass			2,300
	Quinnat salmon		4,922,634	
	Brook trout			2,500
Pennsylvania	Shad		12,100,000	
	Quinnat salmon	100,000		
	Atlantic salmon	100,000		
	Landlocked salmon	3,000		
	Rainbow trout			28,250
	Black bass, large-mouth			3,750
Rhode Island	Rock bass			200
	Landlocked salmon	3,000		
	Brook trout		16,000	
	Black bass, large-mouth			3,515
South Carolina	Lobster		2,564,000	
	Shad		1,975,000	
	Black bass, large-mouth			2,100
South Dakota	Rock bass			1,800
	Rainbow trout		900	3,400
	Brook trout			3,500
	Black bass, large-mouth			1,075
	Rock bass			2,500
Tennessee	Rainbow trout		10,000	6,625
	Black bass, large-mouth			1,750
	Crappie			475
	Rock bass			1,025
Texas	Rainbow trout			1,650
	Black bass, large-mouth			19,300
	Rock bass			7,120
	Rainbow trout		2,500	
Utah	Brook trout	55,000		400
	Quinnat salmon		188,714	
Vermont	Atlantic salmon		1,330	
	Landlocked salmon			1,516
	Rainbow trout	50,000		1,000
	Von Behr trout			836
	Brook trout	65,000	223,704	4,362
	Lake trout	200,000		
	Swiss Lake trout			6,000
	Black bass, large-mouth			1,200
	Shad		7,842,000	
	Rainbow trout		71,500	14,375
Virginia	Black bass, large-mouth			10,575
	Crappie			50
	Rock bass			3,800
	Quinnat salmon		1,848,760	
	Brook trout			1,000
Washington	Rainbow trout			3,750
	Black bass, large-mouth			1,974
	Black bass, small-mouth			888
	Rock bass			140
Wisconsin	Steelhead trout		10,000	
	Brook trout		52,000	
	Lake trout		2,610,000	
	Black bass, large-mouth			600
Wyoming	Loch Leven trout	10,000		
	Rainbow trout	45,825	500	
	Brook trout	25,000		4,500
	Lake trout	200,000		
FOREIGN COUNTRIES.				
France	Quinnat salmon	100,000		
	Rainbow trout	70,000		
Germany	Quinnat salmon	50,000		
	Lake trout	25,000		
Italy	Landlocked salmon	10,000		
Canada	Lake trout		240,000	
Total		23,565,790	542,360,000	2,218,252

REPORT OF COMMISSIONER OF FISH AND FISHERIES. LXXVII

Details of distribution.

Species and disposition.	Eggs.	Fry and fingerlings.	Adults and yearlings.
Shad:			
Connecticut River, Deep River, Conn.....		1,540,000	
State Fish Commission, Gillhill, Conn.....		1,440,000	
State Fish Commission, Joshuatown, Conn.....		2,500,000	
Brandywine Creek, Wilmington, Del.....		4,606,000	
Appoquinimuk Creek, Middletown, Del.....		720,000	
Smyrna River, Clayton, Del.....		960,000	
St. Johns River, Dover, Del.....		660,000	
Murderkill Creek, Feltou, Del.....		780,000	
Mispillion River, Milford, Del.....		750,000	
Blackbird Creek, Middletown, Del.....		240,000	
Little Duck Creek, Cheswald, Del.....		180,000	
Indian River, Millsboro, Del.....		960,000	
Eastern Branch of Potomac River, Bennings, D. C.....		4,090,000	
Potomac River, Long Bridge, D. C.....		535,000	
Potomac River, opposite Fish Ponds, D. C.....			1,500,000
Lake Monroe, Sanford, Fla.....		2,010,000	
St. Johns River, Little Lake George, Fla.....		7,500	
Savannah River, Augusta, Ga.....		1,200,000	
Ogeechee River, Midville, Ga.....		500,000	
Ocmulgee River, Macon, Ga.....		500,000	
Flint River, Reynolds, Ga.....		200,000	
Chesapeake Bay, Havre de Grace, Md.....		13,562,000	
Bush River, Bush River Station, Md.....		3,150,000	
Gunpowder River, Gunpowder Station, Md.....		2,700,000	
Pataasco River, Relay, Md.....		900,000	
Patuxent River, Laurel, Md.....		886,000	
Potomac River, Point of Rocks, Md.....		3,139,000	
Wicomico River, Salisbury, Md.....		900,000	
Tuckahoe Creek, Queen Anne, Md.....		900,000	
Chester River, Chestertown, Md.....		900,000	
Susquehanna River, Port Deposit, Md.....		1,425,000	
Susquehanna River, on Susquehanna Flats, near Havre de Grace, Md.....		750,000	
Potomac River, Moxley Point, Md.....		781,000	
Potomac River, Fort Foote, Md.....		239,000	
Potomac River, Bryan Point, Md.....		354,000	
Wankinquoit River, Wareham, Mass.....		450,000	
Rancoocas Creek, Burlington, N. J.....		1,800,000	
Cohansey Creek, Bridgeton, N. J.....		900,000	
Timber Creek, Gloucester, N. J.....		6,011,000	
Woodbury Creek, Woodbury, N. J.....		3,000,000	
Delaware River, Lambertville, N. J.....		3,142,000	
Delaware River, off Howell Cove, N. J.....		3,837,000	
Delaware River, near Billingsport, N. J.....		5,669,000	
Delaware River, Milford, N. J.....		2,250,000	
Delaware River, near Gloucester, N. J.....	761,000		
Delaware River, off Howell Cove, N. J.....	1,609,000		
Delaware River, near Billingsport, N. J.....	449,000		
Delaware River, Callicon, N. Y.....		900,000	
Delaware River, Port Jervis, N. Y.....		900,000	
Hudson River, Kingston, N. Y.....		450,000	
Hudson River, Cornwall, N. Y.....		450,000	
Hudson River, Newburg, N. Y.....		450,000	
New York State Fish Commission, Albany, N. Y.....		5,775,000	
Albemarle Sound, off Edenton, N. C.....		15,014,000	
Albemarle Sound, Ayoca, N. C.....		400,000	
Roanoke River, Plymouth, N. C.....		1,497,000	
Six Run, Six Runs, N. C.....		450,000	
Juniata River, Millerstown, Pa.....		400,000	
Susquehanna River, Fites Eddy, Pa.....		3,150,000	
Susquehanna River, Columbia, Pa.....		2,700,300	
Susquehanna River, Peach Bottom, Pa.....		2,700,000	
Delaware River, Delaware Water Gap, Pa.....		2,250,000	
Delaware River, Lackawaxen, Pa.....		900,000	
Pee Dee River, Florence County, S. C.....		300,000	
Santee River, Williamsburg, S. C.....		300,000	
Goose Creek, Mount Holley, S. C.....		275,000	
Edisto River, Jacksonboro, S. C.....		300,000	
Ashpoo River, Ashepoo, S. C.....		275,000	
Salkelutchie River, Salkelutchie, S. C.....		275,000	
Coosawhatchie River, Coosawhatchie, S. C.....		250,000	
Chappawanatic River, Quantico, Va.....		900,000	
Ocoquan River, Woodbridge, Va.....		745,000	
Tye River, Tye River Station, Va.....		452,000	
Rapidan River, Rapidan, Va.....		453,000	
Rappahannock River, Fredericksburg, Va.....		853,000	
Rockfish River, Rockfish, Va.....		452,000	
Cedar Run, Catletts, Va.....		830,000	

NOTE.—3,036,000 shad were released in the fish ponds, Washington, D. C., for rearing, but these are not to be included in the summation. There were lost en route by messengers 1,012,000.

LXXVIII REPORT OF COMMISSIONER OF FISH AND FISHERIES.

Details of distribution—Continued.

Species and disposition.	Eggs.	Fry and fingerlings.	Adults and yearlings.
<i>Shad</i> —Continued.			
Little River, Taylorsville, Va.		841,000	
Potomac River, Wide Water, Va.		902,000	
Mattaponi River, Millford, Va.		904,000	
Nansemond River, Suffolk, Va.		450,000	
Total	*2,819,000	130,226,500	1,500,000
<i>Quinnat salmon:</i>			
McCloud River, near Baird, Cal.		1,078,086	
Mad River and North Fork, near Korbek, Cal.		145,385	
Minor and Redwood creeks, near Fort Gaston, Cal.		280,250	
Pit River, near Baird, Cal.		20,000	
South Fork of Bear Valley Creek, near Olema, Cal.		35,000	
Bear Valley Creek, near Olema, Cal.		100,000	
Paper Mill Creek, near Masza Ranch, Cal.		50,000	
Paper Mill Creek, near Codoni Ranch, Cal.		50,000	
Paper Mill Creek, near Jewell Ranch, Cal.		50,000	
Dutch Bill Creek, near Olema, Cal.		100,000	
Nicasio Creek, near Gonzoli Ranch, Cal.		50,000	
Olema Creek, near Crossroads, Cal.		50,000	
Olema Creek, near Blumo's Ranch, Cal.		100,000	
Olema Creek, near Abbott's Ranch, Cal.		50,000	
California Fish Commission, Sisson, Cal.	17,982,590		
Maine Fish Commission, Monmouth, Me.	5,000		
Commodore Club, Hartland, Me.	25,000		
Williams Brook, Bucksport, Me.		19,995	3,597
Heart Pond, Orland, Me.			2,892
Toddy Pond, Orland, Me.		7,994	513
Branch Pond Stream, Ellsworth Falls, Me.		420,000	
Union River, Ellsworth Falls, Me.		379,500	
Pattons Pond Stream, Ellsworth Falls, Me.		95,000	
Penobscot River, Brewer, Me.		12,500	
Penobscot River, Millford, Me.		51,660	
Penobscot River, Costigan, Me.		53,400	
Penobscot River, Greenbush, Me.		29,400	
Penobscot River, Passadumkeag, Me.		106,800	
Penobscot River, Lincoln Center, Me.		77,400	
Penobscot River, Winn, Me.		106,800	
Penobscot River, Mattawamkeag, Me.		192,010	
Meadow Brook, Orland, Me.		22,200	
Lake Cochnewagon, Monmouth, Me.		50,000	
Port Stream, Orland, Me.		11,998	
Alamoosook Lake, Orland, Me.		15,249	196
Pleasant River, Milo Junction, Me.		30,000	
Pleasant River, Milo, Me.		30,000	
Pleasant River, Brownville, Me.		30,000	
Pleasant River, Brownville Junction, Me.		15,000	
Pleasant River, Katahdin Iron Works, Me.		54,000	
Cabin John Run, Cabin John Bridge, Md.		7,516	
Suncook River, near Concord, N. H.		49,000	
Salmon River, Pulaski, N. Y.		138,000	
Salmon River, Richland, N. Y.		225,000	
Salmon River, Altmar, N. Y.		52,500	
Spring Brook, Pulaski, N. Y.		112,000	
Spring Brook, Richland, N. Y.		225,000	
Reservoir, Richland, N. Y.		50,000	
Clendon Brook, Glens Falls, N. Y.		193,000	
Whipple Creek, Marlon, N. Y.		200,000	
Bragdon Creek, Altmar, N. Y.		52,500	
John Abbott Creek, Altmar, N. Y.		52,500	
Blakeman Creek, Altmar, N. Y.		52,500	
Lake Ontario, off Tibbetts Point, N. Y.		375,000	
Trout Brook, Limerick, N. Y.		20,000	
Fall Mill Creek, Delhi, N. Y.		40,000	
Elk Creek, Delhi, N. Y.		40,000	
Peck Brook, Delhi, N. Y.		40,000	
Steel Brook, Delhi, N. Y.		40,000	
Hong Brook, Delhi, N. Y.		40,000	
St. Lawrence River, Cape Vincent, N. Y.		2,000	
Clackamas River and Clear Creek, Stone, Oreg.		3,706,502	
Clackamas River, Stone, Oreg.		471,132	
Clear Creek, Stone, Oreg.		375,000	
Salmon River, Salmon River, Oreg.		100,000	
Spring Creek, Mapleton, Oreg.		35,000	
Knowles Creek, Mapleton, Oreg.		145,000	
Pennsylvania State Fish Commission, Allentown, Pa.	100,000		
Sleepers River, near St. Johnsbury, Vt.		40,600	
Sleepers River, Goss Hollow, Vt.		24,000	
Sleepers River, North Danville, Vt.		16,000	

* These eggs were impregnated and deposited in the Delaware River, New Jersey.

REPORT OF COMMISSIONER OF FISH AND FISHERIES. LXXIX

Details of distribution—Continued.

Species and disposition.	Eggs.	Fry and fingerlings.	Adults and yearlings.
<i>Quinnat salmon</i> —Continued.			
Sleepers River, Fairlee, Vt.....		1,500	
Spring Brook, St. Johnsbury, Vt.....		1,000	
Moore Brook, St. Johnsbury, Vt.....		10,000	
Moose River and tributaries, St. Johnsbury, Vt.....		28,000	
Tributaries of Connecticut River, St. Johnsbury, Vt.....		57,444	
Passumpsic River, St. Johnsbury, Vt.....		4,000	
Wells River, Groton, Vt.....		2,970	
Lake Morey, Fairlee, Vt.....		3,200	
Little White Salmon River, near Chenoweth, Wash.....		1,848,760	
Société de Acclimation, Paris, France.....	100,000		
S. Jaffe, Sauffort, Germany.....	50,000		
Total.....	18,262,500	*18,834,261	7,198
<i>Atlantic salmon:</i>			
Connecticut State Fish Commission, Windsor, Conn.....	100,000		
Amos Ellis, Rangely, Me.....	40,000		
Alamooseok Lake, near Orland, Me.....		9,246	41,001
Whites Pond, Penobscot, Me.....			6,200
Toddy Pond, near Orland, Me.....		65,725	46,083
Toddy Pond Tributary, Bluehill, Me.....			7,572
Toddy Pond, near Surry, Me.....			21,104
Toddy Pond, near Bluehill, Me.....			9,100
Heart Pond, near Orland, Me.....		8,000	8,000
Long Pond Tributary, Bucksport, Me.....			6,850
Hancock Pond, near Bucksport, Me.....			8,232
Brewer Pond Tributary, Bucksport, Me.....			8,396
Narramissic River, near Bucksport, Me.....			14,099
Narramissic River, near Orland, Me.....			21,188
Moosehorn River, near Bucksport, Me.....			10,183
Williams Brook, Bucksport, Me.....			1,551
Gardner Meadow Brook, Brewer, Me.....			2,500
Baker Brook, Millford, Me.....			2,500
Penobscot River, Castigan, Me.....		52,500	2,500
Penobscot River, Greenbush, Me.....		55,000	2,500
Penobscot River, Olamon, Me.....			2,500
Penobscot River, Passadunkang, Me.....		155,000	6,750
Penobscot River, Millford, Me.....		50,000	
Penobscot River, Lincoln Center, Me.....		83,000	
Penobscot River, Winn, Me.....		155,000	
Penobscot River, Mattawamkeag, Me.....		482,000	
Great Brook, Otis, Me.....		33,000	
St. Croix River, Vancelboro, Me.....		150,000	
Piscataquis River, Milo Junction, Me.....		27,000	
Piscataquis River, South Sebec, Me.....		54,000	
Piscataquis River, East Dover, Me.....		54,000	
Piscataquis River, Dover and Foxcroft, Me.....		178,200	
Lake Harriman Brook, Orland, Me.....		20,000	
Wardwell Brook, Orland, Me.....		20,000	
Tucker Brook, Orland, Me.....		4,000	
W. S. Haddaway, Chiltonville, Mass.....	25,000		
New York State Fish Commission, Cold Spring Harbor, N. Y.....	100,000		
Adirondack League Club, Fulton Chain, N. Y.....	25,000		
Bragdon Creek, Altmar, N. Y.....		12,000	
John Abbott Creek, Altmar, N. Y.....		12,000	
Salmon River, Altmar, N. Y.....		12,000	
Blakeman Creek, Altmar, N. Y.....		12,000	
Pennsylvania State Fish Commission, Corry, Pa.....	100,000		
Peacham Pond, Peacham, Vt.....		1,350	
Total.....	390,000	1,705,010	†234,790
<i>Landlocked salmon:</i>			
California Fish Commission, Sisson, Cal.....	10,000		
Commodore Club, Hartland, Me.....	5,000		
Caleb Gilman, Eastport, Me.....	5,000		
Parmachenee Club, Camp Caribou, Me.....	10,000		
Great Brook, near Otis, Me.....		35,000	
Winkemphugh Brook, Hancock County, Me.....		20,000	
Patton Pond, near Ellsworth Falls, Me.....		3,000	
Floods Pond, near Ellsworth Falls, Me.....		3,000	
Toddy Pond, near Surry, Me.....			5,313
Toddy Pond, near Orland, Me.....			3,573
Green Lake, near Green Lake, Me.....			2,164
Michigan State Fish Commission, Detroit, Mich.....	5,000		
New Hampshire State Fish Commission, Ashland, N. H.....	5,000		
A. M. Bigelow, Branchville, N. J.....	3,000		
Ed. Hayes, Buffalo, N. Y.....	3,000		
Adirondack League Club, Fulton Chain, N. Y.....	5,000		

* Lost en route, fry 8,343; yearlings 203.

† Lost en route, fry 31,002; yearlings 373.

LXXX REPORT OF COMMISSIONER OF FISH AND FISHERIES.

Details of distribution—Continued.

Species and disposition.	Eggs.	Fry and fingerlings.	Adults and yearlings.
<i>Landlocked salmon—Continued.</i>			
Tuxedo Club, Tuxedo Park, N. Y.	10,000		
Wm. J. Coon, Glensyre, Pa.	3,000		
Rhode Island State Fish Commission, Providence, R. I.	3,000		
Peacham Pond, Lanesboro, Vt.			1,516
<i>Foreign countries:</i>			
Royal Geographical Society, Rome, Italy	10,000		
Total	77,000	61,000	* 12,566
<i>Silver salmon:</i>			
Mad River and North Fork, near Korbek, Cal.		173,387	
Redwood Creek, near Blair's Ranch, Cal.		124,750	
Total		298,137	
<i>Steelhead trout:</i>			
Redwood Creek, Blair's Ranch, Cal.		202,000	
North Fork, Korbek, Cal.		15,000	
Mad River, Korbek, Cal.		40,000	
Turner Pond, Isle au Haut, Me.			3,000
Silver Lake, Katahdin Iron Works, Me.		25,000	
Smith Brook, Bucksport, Me.		24,989	
Craig Brook, Orland, Me.		2,000	
Heart Pond, Orland, Me.		3,750	1,700
Craig Pond, Orland, Me.			1,800
Tributaries of Hothole Pond, Orland, Me.			1,682
Long Pond, Bucksport, Me.			2,083
State Fish Commission, East Auburn, Me.			200
Smith Creek, Emery Junction, Mich.		6,000	
Silver Creek, East Tawas, Mich.		6,000	
Pine River, West Harrisonville, Mich.		5,000	
Pere Marquette River, and tributaries, Baldwin, Mich.		15,000	
State Fish Commission, St. Paul, Minn.		20,000	
Stewart River, Two Harbors, Minn.		6,000	
Eagle Nest Lake, Tower, Minn.		3,000	
Cross River, Lutsen, Minn.		5,000	
Poplar River, Lutsen, Minn.		5,000	
Devils Track River, Grand Marais, Minn.		10,000	
Sucker River, Duluth, Minn.		15,000	
Lovells and East Lakes, Sanbornville, N. H.		10,000	
White Lake, Franklin Junction, N. J.		3,000	
State Fish Commission, Caledonia, N. Y.	50,000		
Tuxedo Club, Tuxedo Park, N. Y.		5,300	
Lake Ontario, off Grandier Isle, N. Y.		2,000	
Battery Park Aquaria, New York City, N. Y.			100
Brule River, Brule, Wis.		10,000	
Total	50,000	† 439,045	10,645
<i>Loch Leven trout:</i>			
California State Fish Commission, Sisson, Cal.	10,000		
Col. S. B. M. Young, Sisson, Cal.	10,000		
Applicants in Colorado			500
M. A. Bigelow, Evanston, Ill.	2,000		
Shipley Branch, Towson, Md.		2,209	
Sturgeon River, Wolverine, Mich.		5,000	
Sturgeon River, Gaylord, Mich.		10,000	
State Fish Commission, Laramie, Wyo.	10,000		
Total	32,000	17,209	500
<i>Rainbow trout:</i>			
Little River, Dekalb, Ala.			800
Applicants in Alabama			1,300
Prairie Creek, Rogers, Ark.			1,000
Cave Spring, Rogers, Ark.			1,000
Flint Creek, Siloam Springs, Ark.			4,000
Ballard Creek, Ballard, Ark.			4,000
Applicants in Arkansas			1,750
Supply Creek, Hoopa, Cal.			5,000
Hostler Creek, Hoopa, Cal.			10,000
Mill Creek, Hoopa, Cal.		10,000	15,000
Pine Creek, Cal.		12,000	
South Platte River, near Buffalo, Colo.		5,000	
Pine River, Pine River, Colo.		5,000	
Lake Loveland, Loveland, Colo.		3,000	
Applicants in Colorado at Leadville			8,000
State Fish Commission, Hartford, Conn.	50,000		
Brandywine Creek, Wilmington, Del.			1,000

* Lost en route, 484 yearlings.

† Lost en route, 625 yearlings and 311 fry.

REPORT OF COMMISSIONER OF FISH AND FISHERIES. LXXXI

Details of distribution—Continued.

Species and disposition.	Eggs.	Fry and fingerlings.	Adults and yearlings.
<i>Rainbow trout</i> —Continued.			
Pond in Zoological Park, District of Columbia			200
Rock Creek in Zoo and Rock Creek Parks, District of Columbia		7,479	
Little River, Gainesville, Ga.			425
Star Creek, Mineral Bluff, Ga.			425
Hemptown Creek, Mineral Bluff, Ga.			850
Young Stone Creek, Mineral Bluff, Ga.			425
Sawmill Creek, Mineral Bluff, Ga.			425
Hothouse Creek, Mineral Bluff, Ga.			425
Panther Creek, Fannin County, Ga.		10,000	
Applicants in Georgia			450
Lake Cliff, Beaver Canyon, Idaho		1,500	
Applicants in Indian Territory			200
Evans Lake, Rush Springs, Indian Territory			500
Barren Fork off Illinois River, Indian Territory			4,000
Sallisaw River, Sallisaw, Indian Territory			2,973
Applicants in Iowa		3,000	
Lakes Okoboji, Spirit Lake, Iowa		15,000	
Spring Brook, Moutezuma, Iowa		3,000	
Cedar River, Cedar Rapids, Iowa		7,000	
Spring Branch, Manchester, Iowa		5,000	
Trout Run, Decorah, Iowa		8,222	
Applicants in Kansas			5,200
Chikaskia River, Drury, Kans.			1,000
Applicants in Kentucky			395
Fern Lake, Middleboro, Ky.			500
Applicants in Maine			281
Cargill Pond, Thorudike, Me.			1,000
Alamoosook Lake, Orland, Me.			6,121
Applicants in Maryland			484
Mosners Brook, Reisterstown, Md.			500
Western Run, Reisterstown, Md.			500
Little Elk Creek, Cherry Hill, Md.			500
Jackson Run, Lonaconing, Md.			250
Nine Mile Pond, Centerville, Mass.			500
Deer Creek, Spring Valley, Minn.		200	
Applicants in Mississippi			500
Elk Creek, Elk Creek, Mo.			2,000
Roubivoux Creek, Crocker, Mo.			1,000
Ebb and Flowing Springs, Crocker, Mo.			500
James River, Turner, Mo.			2,000
Justice Branch of Piney Creek, Cabool, Mo.			1,000
Jacks Fork of Current River, Mountain View, Mo.			3,700
Piney Creek, Cabool, Mo.			2,000
Hickory Creek, Neosho, Mo.			275
Five Mile Creek, Hornet, Mo.			275
Applicants in Missouri		19,000	2,980
Spring Lake, Springfield, Mo.		8,000	
Agnes Lake, Browus, Mont.		1,500	
State Fish Commission, Elko, Nev.			
State Fish Commission, Ashland, N. H.	50,375		
Crystal Lake, Enfield, N. H.	50,000		1,000
A. M. Bigelow, Branchville, N. J.			
Lebaun Stream, Gronlock, N. J.	25,000		500
Black and Beaver Brooks, Newton, N. J.			900
Deep Run, Old Bridge, N. J.			700
Back Run, Back Run, N. J.			400
Tributary of Walkkill River, Sparta, N. J.			340
Black Creek, Franklin Junction, N. J.			
Applicants in New Mexico		2,000	1,000
Baldoss and Eaglecreeks, White Oaks, N. Mex.			1,752
Pecos River, Ribera, N. Mex.			500
West Branch of Unadilla River, Bridgewater, N. Y.			
Shinglekill and Catskill creeks, Catskill, N. Y.		4,000	
Tiquin and Lathrop brooks, Sherburne, N. Y.		4,000	
Houghtaling Brook, Oneonta, N. Y.		4,000	
Lake George, Lake George, N. Y.			1,000
Applicants in North Carolina		14,000	550
Chetola Lake, Lenoir, N. C.			400
Tuckaseigee River, Sylva, N. C.			400
Crabtree Creek, Raleigh, N. C.			485
Ivy Creek, Asheville, N. C.			400
Canyfork Creek, Sylva, N. C.			400
Nantihala River, Andrews, N. C.			1,000
Banner Elk Creek, Elk Park, N. C.			400
Dicks Creek, Dillsboro, N. C.			400
Little Creek, Mars Hill, N. C.			400
Laurel Creek, Mars Hill, N. C.			400
Middle Fork of French Broad, Brevard, N. C.			380
Base Lake, Biltmore, N. C.			300
East Fork of Pigeon River, Canton, N. C.			500

LXXXII REPORT OF COMMISSIONER OF FISH AND FISHERIES.

Details of distribution—Continued.

Species and disposition.	Eggs.	Fry and fingerlings.	Adults and yearlings.
<i>Rainbow trout</i> —Continued.			
Cranberry Creek, Cranberry, N. C.			400
Crystal Lake, Twinsburg, Ohio		1,500	
Hoover Lake, Akron, Ohio		3,000	
Applicants in Ohio		2,000	
Applicants in Oklahoma			7,591
Cacho Creek, Chickasha, Oklahoma			950
Applicants in Pennsylvania			1,800
Jones Creek, Ebensburg, Pa.			175
West Branch of Quecus Run, Lockhaven, Pa.			2,000
Falling Spring, Chambersburg, Pa.			900
Bently Creek and Pond, Tioga, Pa.			900
Hammer Creek, Lebanon, Pa.			400
Killinger Creek, Lebanon, Pa.			300
Mancils Run, Norristown, Pa.			600
Rapid Run, Montandon, Pa.			600
Piney Creek, Altoona, Pa.			300
White Deer Creek, Milton, Pa.			300
Bloody Run, Gaines, Pa.			300
Laurel Run, Nicholson, Pa.			400
Long Run, Gaines, Pa.			600
Gall Run, Gaines, Pa.			300
Pike Creek, Wyoming, Pa.			300
Mill Run, Gaines, Pa.			1,200
Tumbling Run Lake, Pottsville, Pa.			300
Letort Creek, Carlisle, Pa.			300
Smethers Creek, Beachhaven, Pa.			300
Shickshinny Creek, Shickshinny, Pa.			300
West Branch of Shickshinny Creek, Shickshinny, Pa.			300
Stony Brook, Moosic, Pa.			300
North Branch of Tobys Creek, Dallas, Pa.			300
Silver Lake, Pottsville, Pa.			300
Baker Creek, Coudersport, Pa.			300
Mill Creek, Coudersport, Pa.			300
Alleghany River, Coudersport, Pa.			900
Sinking Run, Tyrone, Pa.			300
Chaffee Run, Gaines, Pa.			300
Bowman Creek, Dallas, Pa.			300
Huntington Creek, Shickshinny, Pa.			400
Bear Creek, Bear Creek, Pa.			300
Spring Cabin Run, Tobyhanna Mills, Pa.			400
Tobyhanna Creek, Tobyhanna Mills, Pa.			600
Harvey Creek, Wyoming, Pa.			300
Mill Creek, Miners Mills, Pa.			300
Framo Cabin Creek, Scranton, Pa.			400
Spring Run, Altoona, Pa.			300
Clover Creek, Altoona, Pa.			300
Bengully Creek, Gaines, Pa.			300
Phoenix Creek, Gaines, Pa.			300
Thompson Run, Gaines, Pa.			300
Shinhollow Run, Gaines, Pa.			300
Lick Run, Gaines, Pa.			300
Black Rock Run, Gaines, Pa.			300
Blue Run, Gaines, Pa.			300
Four Mile Run, Gaines, Pa.			300
Painter Run, Gaines, Pa.			300
Spring Run, Greencastle, Pa.			300
South Branch of Wallenpaupac Creek, South Sterling, Pa.			300
Black Lick Creek, Ebensburg, Pa.			175
Trout Run, Shippensburg, Pa.			300
Clover Creek, Martinsburg, Pa.			600
Toms Creek, Muddy Creek Forks, Pa.			300
Mill Creek, Lebanon, Pa.			300
Nescoopeck Creek, Tunnel, Pa.			300
Lick Run, Lockhaven, Pa.			1,000
Beek Creek, Lebanon, Pa.			400
Stone Creek, Lebanon, Pa.			400
Trout Run, Bedford, Pa.			300
Wyomissing Creek, Reading, Pa.			300
Dunning Creek, Bedford, Pa.			300
Spring Run, Brookville, Pa.			300
North Branch of Little Conemaugh River, Wilmore, Pa.			500
Applicants in South Dakota			600
Sioux River, Brookings, S. Dak.			1,000
Gould Lake, Rapid City, S. Dak.		900	
Split Rock River, Garretson, S. Dak.			800
Split Rock Creek, Brandon, S. Dak.			900
Wall Lake, Sioux Falls, S. Dak.			100
Applicants in Tennessee		1,000	775
Emory River, Harriman, Tenn.			500
Indian Creek, Erwin, Tenn.			500

REPORT OF COMMISSIONER OF FISH AND FISHERIES. LXXXIII

Details of distribution—Continued.

Species and disposition.	Eggs.	Fry and fingerlings.	Adults and yearlings.
<i>Rainbow trout—Continued.</i>			
Big Creek, Newport, Tenn.			500
Big Pigeon River, Newport, Tenn.			1,000
Gap Creek, Johnson City, Tenn.			500
Red River and tributaries, Gloucelen, Tenn.			750
Big Stony Creek, Elizabethton, Tenn.			400
Cedar Creek, Lebanon, Tenn.			200
Laurel Fork and Doo River, Hampton, Tenn.			1,000
Barren Fork of Collins River, McMinnville, Tenn.			500
Little River, Maryville, Tenn.		5,000	
South Indian Creek, Erwin, Tenn.		5,000	
Laurel and Big creeks, Delrio, Tenn.		5,000	
Applicants in Texas			1,050
Applicants in Utah		1,500	
Jordan River, Salt Lake City, Utah		1,000	
State fish commissioners, Roxbury, Vt.	50,000		
Beaver Pond, Proctor, Vt.			1,000
Applicants in Virginia		2,000	3,550
Four Mile Creek, Richmond, Va.			1,000
Spring Fork of Clinch River, Pounding Mill, Va.			400
Forest Hill Park Lake, Richmond, Va.			500
Clinch River, Tazewell, Va.			800
Peerys Branch, Tazewell, Va.			400
Moormans River, Charlottesville, Va.			1,000
Shoomaker River, Wythoville, Va.			500
Spring Branch, Preconion Springs, Va.			400
Opequan Creek, Lenora, Va.			500
Smith and Wilson creeks, Clifton Forge, Va.			450
Clear Fork Creek, Tazewell, Va.			400
Stock Creek, Horton Summit, Va.			500
Little Ogles Creek, Dunlap, Va.			475
Chestnut Creek, Gossan, Va.			1,000
Scotts Run, Lewinsville, Va.			500
Four Mile Run, Glencarlin, Va.			500
Calvin Run, Wiehle, Va.			500
Big Spring, Leesburg, Va.			1,000
Powell River, Bigstone Gap, Va.		20,000	
Irish Creek, Cornwall, Va.		5,000	
Beaver Dam Branch, Springwood, Va.		10,000	
Mill Creek, Christiansburg, Va.		10,000	
Callahan Creek, Stonoga, Va.		10,000	
Orix Creek, Evington, Va.		8,500	
St. Clair Creek, St. Clair Bottom, Va.		1,000	
Mason Creek, Salem, Va.		5,000	
Applicants in West Virginia			1,175
Lake Terra Alta, Terra Alta, W. Va.			400
Big Stony Creek, Lowell, W. Va.			475
Long Run, Douglas, W. Va.			500
Lake Ford, Cranesville, W. Va.			500
Decker Creek, Morgantown, W. Va.			200
Cascade Brook, Millville, W. Va.			500
State Fish Commission, Laramie, Wyo.			
Dome Lake, Sheridan, Wyo.	45,825	500	
Jules de Guerne, Paris, France	50,000		
Fécamp, France	20,000		
Total	341,200	254,801	* 172,122
<i>Von Behr trout:</i>			
Country Club, San Francisco, Cal.		8,000	
Summit Lake and Fishtang Creek, Trinity Summit, Cal.		7,500	
Trinity Lake, Hoopa, Cal.		6,600	275
State Fish Commission, Holden, Mo.			569
Blake Pond, Sutton, Vt.			836
Total		22,100	1,680
<i>Black-spotted trout: †</i>			
Mammoth Creek, Mammoth Lakes, Colo.		21,100	
Twin Lakes, Twin Lakes, Colo.		17,600	
Froeman Lake, Wolcott, Colo.		3,500	
Total		42,200	
<i>Brook trout:</i>			
A. A. Bartlett, Rogers, Ark.	6,000		
Applicants in Colorado		21,000	3,000
Catch in Poudre Creek, Fort Collins, Colo.			5,000
South Platte River, between Webster and Buffalo, Colo.			10,000

* Lost en route, 9,309 yearling and 14,100 fry; 1,000 fry and 5,000 eggs sent to Nashville, Tenn.
 † 5,000 eggs sent to Nashville, Tenn.

LXXXIV REPORT OF COMMISSIONER OF FISH AND FISHERIES.

Details of distribution—Continued.

Species and disposition.	Eggs.	Fry and fingerlings.	Adults and yearlings.
<i>Brook trout</i> —Continued.			
Pino River, Pino River, Colo.			5,000
Lake Creek Lake, Cotopaxi, Colo.			2,000
Crystal River, Carbondale, Colo.			5,000
Middle Lake, Lake County, Colo.			1,000
Eagle River, Berry Station, Colo.		20,000	3,000
Upper Evergreen Lake, Colo.			6,000
Lower Evergreen Lake, Lake County, Colo.			11,200
Lake San Cristobal, Colo.		5,000	
Fish and Spring Creek, Virginia Dale, Colo.			2,000
Silver Lake, Monte Vista, Colo.		5,000	
Silver Lake, Montrose, Colo.		3,000	
Geneva Creek, Grant, Colo.		12,000	
Silver Lake, Dillon, Colo.		3,000	
Buzzards Bay Lake, Thomasville, Colo.		5,000	
Gray Gables Lake, Thomasville, Colo.		5,000	
Box Creek Lake, Leadville, Colo.		2,000	
Tumbling Rock Creek, Woodland Park, Colo.		5,000	
Lake Loveland, Loveland, Colo.		2,700	
Elk Creek, Pine Grove, Colo.		10,000	
North Fork of Frying Pan Creek, Norrie, Colo.		23,000	
Limo Creek, Thomasville, Colo.		15,000	
South Platte River, Hartsel, Colo.		10,000	
Craig Creek, Eatabrook, Colo.		5,000	
North Fork of Platte River, Bailey, Colo.		5,000	
Lower Craig Creek, Eatabrook, Colo.		5,000	
North Fork of South Platte River, Grant, Colo.		5,000	
North Fork of South Platte River, Eatabrook, Colo.		5,000	
North Fork of South Platte River, South Platte, Colo.		5,000	
North Fork of Platte River, Ferndale, Colo.		5,000	
Platte River, Ferndale, Colo.		5,000	
South Fork of Platte River, South Platte, Colo.		5,000	
Buffalo Creek, Buffalo, Colo.		5,000	
Carbon and Castle creeks, Gunnison, Colo.		5,000	
Gunnison River, Gunnison, Colo.		5,000	
Blue River, Breckenridge, Colo.		5,000	
Clear Creek, Empire, Colo.		5,000	
Clear Creek, Idaho Springs, Colo.		10,000	
Clear Creek, Dumont, Colo.		5,000	
Chicago Creek, Idaho Springs, Colo.		5,000	
South Platte River, Cliff, Colo.		5,000	
Rouring Fork River, Aspen, Colo.		10,000	
Straight Creek, Dillon, Colo.		5,000	
Willow Creek, Dillon, Colo.		5,000	
Platte River, between Grant and South Platte, Colo.		25,000	
State Fish Commission, Windsor, Conn.	25,000		
Applicants in Connecticut.		5,000	
East River, New Hartford, Conn.		10,000	
Tributaries of Nachang River, Hartford, Conn.		5,000	
Spring Brook, Bridgeport, Conn.		5,000	
Stillman Brook and Reservoir, Bridgeport, Conn.		10,000	
Tuttle Brook, New Haven, Conn.		5,000	
Five Mile River, South Norwalk, Conn.		15,000	
Spring Branch, Roxbury Falls, Conn.		31,000	
Cold Spring Brook, South Norwalk, Conn.		10,000	
Rowayton Brook, South Norwalk, Conn.		5,000	
Barnum Brook, South Norwalk, Conn.		8,000	
Silver Mine Brook, South Norwalk, Conn.		10,000	
Chestnut Hill Brook, South Norwalk, Conn.		5,000	
Tower Brook, South Norwalk, Conn.		5,000	
Horse Swamp Brook, South Norwalk, Conn.		5,000	
Guthrie Brook, South Norwalk, Conn.		5,000	
Comstock and Barretts Brook, Wilton, Conn.		5,000	
Norwalk Stream, Norwalk, Conn.		5,000	
Cold Spring Brook, Wilton, Conn.		10,000	
Wilton Brook, Wilton, Conn.		5,000	
Brewers Creek, Bridgeport, Conn.		5,000	
Mill River, Bridgeport, Conn.		10,000	
Peck Spring Brook, Bridgeport, Conn.		5,000	
Spring Brook, Cannon, Conn.		2,000	
Spring Brook, Wilton, Conn.		5,000	
Clark Brook, Hartford, Conn.		5,000	
Norwalk River, South Wilton, Conn.		5,000	
Horseneck Brook, Greenwich, Conn.		3,198	
Geo. W. Rea, Beaver Canyon, Idaho.	5,000		
Beaver Canyon Creek, Beaver Canyon, Idaho.			1,000
Willow Creek, Beaver Canyon, Idaho.			1,000
Sheridan Creek, Beaver Canyon, Idaho.			1,000
Sheridan Lake, Beaver Canyon, Idaho.			3,000
Lost River, Lost River, Idaho.			500
Smith Creek, Bliss, Idaho.			

REPORT OF COMMISSIONER OF FISH AND FISHERIES. LXXXV

Details of distribution—Continued.

Species and disposition.	Eggs.	Fry and fingerlings.	Adults and yearlings.
<i>Brook trout</i> —Continued.			
M. A. Bigelow, Evanston, Ill.	12,000		
Applicants in Illinois		1,000	
Applicants in Iowa at Cedar Rapids		4,700	
Clear Creek, Lansing, Iowa		10,000	
Parmachence Club, Camp Caribou, Me	30,000		
Applicants in Maine			519
Green Lake, Otis, Me		5,000	
Winkempanugh Brook, Hancock County, Me		25,000	
Pattons Pond, Ellsworth Falls, Me		17,000	
Floods Pond, Ellsworth Falls, Me		3,000	
Applicants in Maryland			25
Offuts Branch, Towson, Md		2,202	
Bakers Trout Pond, Hanover, Mass		4,000	
Chelmsford Brook, Lowell, Mass		4,000	
Tributaries of Assonet River, Taunton, Mass		4,000	
Mashpee Lake, Sandwich, Mass		4,000	
Garretts and Hadway Pond, Hyannis, Mass		5,630	
Applicants in Massachusetts at Green Lodge		4,000	
Champion Brook, Tecumseh, Mich		5,000	
Cedar and Glass creeks, Hastings, Mich		2,500	
Hayward Lake, Casnovia, Mich		5,000	
Bietner Creek, Grand Rapids, Mich		5,000	
Applicants in Michigan		4,000	
Deer Creek, Spring Valley, Minn		1,800	
Poplar River, Lutsen, Minn		3,000	
Applicants in Minnesota		2,000	
State Fish Commission, St. Paul, Minn	25,000		
Applicants in Montana			1,500
Spring Creek, Livingston, Mont			2,000
Box Elder Creek, Havre, Mont			2,000
Applicants in Nebraska			1,000
State Fish Commission, Southbend, Nebr	25,000		
Samuel M. Pearson, Stratham, N. H.	10,000		
Winnicut Lake, Dover, N. H.		4,000	
Crystal Lake, Enfield, N. H.		4,000	
Saucook River, Concord, N. H.		8,000	
Spring Brook, Grafton, N. H.		4,000	
A. M. Bigelow, Branchville, N. J.	10,000		
Adirondack League Club, Old Forge, N. Y.	25,000		
State Fish Commission, ColdSpring Harbor, N. Y.			500
Struly Lake, Oaks, N. Dak		4,000	
Forest River, Larimore, N. Dak		2,000	
Applicants in North Dakota		2,000	
Castalia Club, Castalia, Ohio			
Slippery Rock Creek, Mahoning, Ohio	15,000		
Applicants in Ohio		5,000	
Crater Lake, Medford, Oreg		3,000	
Lake Whoahink, Ada, Oreg			1,000
Applicants in Oregon			1,000
Queens and Beaver rivers, Kingston, R. I.		8,000	500
Applicants in Rhode Island		8,000	
Sylvan Lake, Custer, S. Dak			1,500
Spearfish Creek, S. Dak			2,000
George A. Trumbo, Salt Lake City, Utah	5,000		
C. E. Tullhurst, Salt Lake City, Utah	5,000		
Grant Hampton, Salt Lake City, Utah	10,000		
L. C. Miller, Salt Lake City, Utah	10,000		
A. M. Musser, Salt Lake City, Utah	25,000		
Jordan River, Salt Lake City, Utah			400
L. J. Johnson, St. Johnsbury, Vt	15,000		
State Fish Commission, Vermont	50,000		
Lakota Lake, Woodstock, Vt.		1,405	
Mount Pulaski fish ponds, Newbury, Vt.		2,985	
Darling Pond, Groton, Vt.		90,870	1,500
Lake Mitchell, Norwich, Vt.		1,490	
Fairbanks Pond, St. Johnsbury, Vt		11,000	
Haystack Brook, Wilmington, Vt		10,000	
Dream Lake Pond, St. Albans, Vt		5,000	
Crystal Pond, West Hartford, Vt.		1,990	
Pico Pond, Pico Pond, Vt.		24,075	
Lake Griffith, Dauby, Vt		4,990	
Caledonia Club Pond, St. Johnsbury, Vt.		10,000	
Caspius Lake, Greensboro, Vt		49,900	2,100
Beaver Pond, Proctor, Vt.			762
Fish Lake, Cheney, Wash			1,000
Big Spring Brook, Cumberland, Wis		5,000	
Trappe Creek, Monico, Wis		7,000	
North Branch of Oconto River, Ellis Junction, Wis		15,000	
Crystal Lake, Dodgeville, Wis		5,000	
Bass Lake, Gordon, Wis		10,000	

LXXXVI REPORT OF COMMISSIONER OF FISH AND FISHERIES.

Details of distribution—Continued.

Species and disposition.	Eggs.	Fry and fingerlings.	Adults and yearlings.
<i>Brook trout</i> —Continued.			
Applicants in Wisconsin		10,000	
State Fish Commission, Laramie, Wyo	25,000		4,500
Dome Lake, Sheridan, Wyo			
Total	332,000	* 943,004	84,506
<i>Lake trout:</i>			
California Fish Commission, San Francisco, Cal	100,000		
Col. S. B. M. Young, Wawona, Cal	25,000		
State Fish Commission, Hartford, Conn	100,000		
M. A. Bigelow, Evanston, Ill.	2,000		
Storm Lake, Storm Lake, Iowa		50,000	
Lakes Okoboji, Spirit Lake, Iowa		55,000	
Clear Lake, Clearlake, Iowa		53,000	
Alamosook Lake, Orland, Me.			3,211
Applicants in Maryland (Carroll County)		4,338	
Nine Mile Pond, Centerville, Mass.			3,000
Long Pond, Falmouth, Mass.			3,200
Baubees Lake, Hillsdale, Mich.		20,000	
Lake Huron, Alpena, Mich.		900,000	
Lake Huron, Cheboygan, Mich.		500,000	
Marble Lake, Quincy, Mich.		10,000	
Lake Michigan, Charlevoix, Mich.		1,010,000	
Lake Michigan, Frankfort, Mich.		495,000	
Pine Lake, Charlevoix, Mich.		480,000	
Lake Huron, East Tawas, Mich.		500,000	
Straits of Mackinaw, Mackinaw, Mich.		480,000	
Little Traverse Bay, Potosky, Mich.		28,000	
Spider Lake, Traverse City, Mich.		20,000	
Lake Michigan, Beaver Island, Mich.		330,000	
Lake Superior, Long Point, Mich.		120,000	
Lake Superior, Washington Harbor, Mich.		120,000	
Lake Superior, Wright Island, Mich.		120,000	
Lake Superior, Fishermans Home, Mich.		120,000	
Lake Superior, Rock Harbor, Mich.		120,000	
Lake Superior, Chippewa Harbor, Mich.		120,000	
Lake Superior, Fish Island, Mich.		120,000	
Lake Superior, Tobins Harbor, Mich.		120,000	
Deer Creek, Spring Valley, Minn.		3,000	
Lake Lizzie, Pelican Rapids, Minn.		50,000	
Lake Superior, Grand Portage, Minn.		240,000	
Lake Superior, Chicago Bay, Minn.		240,000	
Lake Superior, off Poplar River, Minn.		240,000	
Lake Superior, off French River, Minn.		120,000	
Lake Superior, Two Harbors, Minn.		120,000	
Lake Superior, Beaver Bay, Minn.		120,000	
Lake Superior, Grand Marais, Minn.		125,000	
Lake Superior, Duluth, Minn.		30,000	
State Fish Commission, St. Paul, Minn.			
State Fish Commission, Southbend, Nebr.	200,000		
State Fish Commission, Fulton Chain, N. Y.	200,000		
Adirondack League Club, Old Forge, N. Y.	200,000		
Reservoir, Purdy's, N. Y.		* 40,000	
Otsego Lake, Cooperstown, N. Y.		40,000	
Trout Lake, St. Regis Falls, N. Y.		25,000	
Lake Ontario, Grenadier Isle, N. Y.		635,000	
Lake Ontario, head of Galloo Isle, N. Y.		200,000	
Lake Ontario, head of Stony Isle, N. Y.		200,000	
Lake Ontario, Pillar Point, N. Y.		150,000	
Lake Erie, North Bass Island Reef, Ohio		352,000	
Lake Erie, Peuch Point Reef, Ohio		442,400	
State Fish Commission, Vermont	200,000		
Lake Michigan, Sheboygan, Wis.		450,000	
Lake Superior, off Sand Island, Wis.		240,000	
Lake Superior, off Magdalena Island, Wis.		480,000	
Lake Superior, off Basswood Island, Wis.		240,000	
Lake Superior, off Rice Island, Wis.		120,000	
Lake Superior, off Wilkeys Island, Wis.		240,000	
Lake Superior, Oak Island, Wis.		120,000	
Lake Superior, Raspberry Island, Wis.		240,000	
Lake Superior, Bark Point, Wis.		240,000	
Lake Superior, off Cranberry River, Wis.		240,000	
State Fish Commission, Laramie, Wyo	200,000		
Onabruck, Germany	25,000		
Lake Superior, near Port Arthur, Canada		240,000	
Total	1,252,000	† 12,247,738	9,411

* Lost en route, 11,713 yearlings and 4,498 fry.

† Lost en route, 1,000 yearlings, 47,000 fry.

REPORT OF COMMISSIONER OF FISH AND FISHERIES. LXXXVII

Details of distribution—Continued.

Species and disposition.	Eggs.	Fry and fingerlings.	Adults and yearlings.
<i>Swiss lake trout:</i>			
Moose Pond, Hartland, Me.....			3,600
Phillips Lake and Holbrook Pond, Bangor, Me.....			3,400
Micatons Lake, Enfield, Me.....			1,937
Alamoosook Lake, Orland, Me.....			10,045
Adirondack League Club, Old Forge, N. Y.....			1,000
State Fish Commission, Glen Falls, N. Y.....			9,000
Battery Park Aquaria, New York City, N. Y.....			100
Lake George, Lake George, N. Y.....			1,000
Caspian Lake, St. Johnsbury, Vt.....			750
Willoughby Lake, St. Johnsbury, Vt.....			750
Big Fish Pond, St. Johnsbury, Vt.....			500
Fairlee Lake, Fairlee, Vt.....			4,000
Total.....			* 36,082
<i>Yellow-fin trout:</i>			
Mammoth Creek, Mammoth Lakes, Colo.....		3,965	
Twin Lakes, Twin Lakes, Colo.....		3,965	
Total.....		7,930	
<i>Golden trout:</i>			
State Fish Commission, Monmouth, Me.....	10,000		
Winkempangh Brook, Hancock County, Me.....		15,000	
Floods Pond, Ellsworth Falls, Me.....		20,000	
Total.....	10,000	35,000	
<i>Whitefish:</i>			
Lake Michigan, Frankfort, Mich.....		2,500,000	
Lake Michigan, Manistique, Mich.....		4,000,000	
Lake Michigan, Warehouse Fishery, Mich.....		1,000,000	
Lake Michigan, Epoufette, Mich.....		1,000,000	
Lake Michigan, Beaver Island, Mich.....		3,000,000	
Lake Michigan, Mackinaw, Mackinaw City, Mich.....		2,500,000	
Straits of Mackinaw, Mackinaw City, Mich.....		6,000,000	
Lake Huron, North Point, Mich.....		2,000,000	
Lake Huron, Oscoda, Mich.....		2,000,000	
Lake Huron, East Tawas, Mich.....		2,000,000	
Lake Huron, off Scarecrow Island, Mich.....		4,000,000	
Lake Huron, off Alpena, Mich.....		2,000,000	
Lake Superior, Grace Harbor, Mich.....		1,990,000	
Hammond Bay, Hammond Bay, Mich.....		2,000,000	
St. Lawrence River, Cape Vincent, N. Y.....		750,000	
Lake Erie, Ballast Island Reef, Ohio.....		4,200,000	
Lake Erie, Green Island Reef, Ohio.....		6,040,000	
Lake Erie, Peach Point Reef, Ohio.....		5,800,000	
Lake Erie, North Bass Reef, Ohio.....		10,300,000	
Lake Erie, Rattlesnake Reef, Ohio.....		2,400,000	
Lake Erie, Lighthouse Point Reef, Ohio.....		3,250,000	
Lake Erie, Niagara Reef, Port Clinton, Ohio.....		4,920,000	
Lake Erie, Middle Bass Reef, Ohio.....		8,200,000	
Lake Erie, Kelley Island Reef, Ohio.....		3,000,000	
Lake Erie, Loonst Point Shoals, Port Clinton, Ohio.....		3,950,000	
Lake Erie, Cone Reef, Toledo, Ohio.....		2,130,000	
Lake Erie, West Sister Reef, Ohio.....		2,400,000	
Lake Erie, Put-in Bay, Ohio.....		2,015,000	
		924,000	
Total.....		85,049,000	
<i>Yellow perch:</i>			
Fox River, McHenry, Ill.....			1,000
Wabash Railroad Pond, Pittsford Junction, Ill.....			25
<i>Pickrel:</i>			
Fox River, McHenry, Ill.....			1,700
<i>Striped bass:</i>			
Susquehanna River, Port Deposit, Md.....		450,000	
<i>Lake herring:</i>			
Lake Erie, North Bass Reef, Ohio.....		2,660,000	
Lake Erie, Peach Point Reef, Ohio.....		1,400,000	
Lake Erie, Port Clinton, Ohio.....		3,239,000	

* Lost en route, 260 yearlings.

LXXXVIII REPORT OF COMMISSIONER OF FISH AND FISHERIES.

Details of distribution—Continued.

Species and disposition.	Adults and year-lings.	Species and disposition.	Adults and year-lings.
<i>Black bass, large-mouth:</i>		<i>Black bass, large-mouth—Continued.</i>	
Big Mill Creek, Gadsden, Ala.	180	Applicants in Maryland	300
Dog River, Vinegar Bend, Ala.	200	Thompsons Pond, North Abington, Mass.	500
Buck Creek Mill Pond, Dadeville, Ala.	200	Black Pond, Bourne, Mass.	800
Applicants in Alabama at Verbena ..	100	White Island Pond, Bourne, Mass. ...	1,200
Blackfish Lake, Earle, Ark.	350	Applicants in Massachusetts	500
Potomac River, Chain Bridge, D. C. ...	500	Bass Lake, Battle Lake, Minn.	200
Rock Creek, Zoological Park, D. C. ...	2,000	Chicago Lake, Lindstrom, Minn.	200
Ostanaula River, Rome, Ga.	180	Twin Sisters Lake, Canton, Miss.	100
Totterpoll Creek, Pine Mountain, Ga. ...	230	Applicants in Mississippi	558
Mill Pond, Vidalia, Ga.	200	Big River, Irondale, Mo.	300
Little Swift Creek, Higgston, Ga.	200	Five Mile Creek, Hornet, Mo.	210
Little River, Washington, Ga.	200	Applicants in Missouri	1,200
Flint River, Zenith, Ga.	200	Uni n Creek, Madison, Nebr.	300
Applicants in Georgia	300	Applicants in Nebraska	400
Miles Lake, Carlyle, Ill.	200	Silver Lake, Blairtown, N. J.	400
Fox River, McHenry, Ill.	500	Bridgewood Lake, Lucaston, N. J.	200
Pecan River, Kilbourne, Ill.	250	Passaic River, Paterson, N. J.	300
Rock River, Oregon, Ill.	500	Spring Lake, Spring Lake, N. J.	800
Wabash Railroad Pond, Pittsfield Junction, Ill.	30	Sunset Lake, Sowell, N. J.	200
Wood River, Woods, Ill.	100	Green Lake, Hutzville, N. J.	200
Applicants in Illinois	1,700	Mill Pond, Burlington, N. J.	300
Lake James, Angola, Ind.	125	Avis Pond, Sowell, N. J.	200
Pine Lake, Laporte, Ind.	200	Hanna's Reservoir, N. Mex. (Raton). ..	150
Eagle Lake, Warsaw, Ind.	125	Indian River Lake, Sing Sing, N. Y. ...	300
Zachariah Lake, Covington, Ind.	100	Reservoir, Purdy, N. Y.	300
White River, Bedford, Ind.	100	Cub Creek, Wilkeshoro, N. C.	200
Manlove Lake, Cambridge, Ind.	100	Roaring River, Traphill, N. C.	200
Bear Lake, Albion, Ind.	125	Water Works Pond, Charlotte, N. C. ...	200
White River, Mitchell, Ind.	100	Mill Pond, Oxford, N. C.	200
Kingsbury Creek, Kingsbury, Ind.	125	Big Jay River, Mars Hill, N. C.	200
Long Lake, Miller, Ind.	100	Tar River, Oxford, N. C.	200
Simonton Lake, Elkhart, Ind.	125	Little River, Hendersonville, N. C. ...	200
Indian Creek, Crandall, Ind.	150	Applicants in North Carolina	3,900
Porter Lake, Cayuga, Ind.	100	Commet Mill Pond, Canal Fulton, Ohio.	200
Upper Salt Creek, Hiltonville, Ind.	100	Westboro Reservoir, Midland, Ohio. ...	150
White River, Williams, Ind.	100	Muskingum and Tuscarawas Rivers, Coshocton, Ohio.	200
White River and Indian Creek, Shoals, Ind.	100	Chippewa Lake, Ohio.	200
Lake Maxinkuckee, Marmont, Ind.	2,200	Tuscarawas River, Zoar, Ohio.	200
Applicants in Indiana	325	Mosquito Creek, Bristolville, Ohio. ...	100
Nobles Lake, Council Bluffs, Iowa. ...	250	Grand River, Leetonia, Ohio.	200
Nobles Lake, Missouri Valley, Iowa. ...	150	Crystal Lake, Akron, Ohio.	200
Little Iowa River, Lime Springs, Iowa. ...	300	Stone Lake, North Bend, Ohio.	200
Creston Reservoir, Creston, Iowa.	200	Tinkers Creek, Bedford, Ohio.	100
Iowa River, Iowa City, Iowa.	1,100	Applicants in Ohio	1,305
Cedar River, Cedar Rapids, Iowa.	800	Applicants in Oklahoma	200
Cedar River, Vinton, Iowa.	600	Sugar Lake, Wilson's Mills, Pa.	200
Applicants in Iowa	16	Allegheny River, Oil City, Pa.	300
State Fish Commission, Spirit Lake, Iowa.	500	Loyalhanna Creek, Latrobe, Pa.	150
Mill Creek, Maple Hill, Kans.	200	Coninauga Creek, Warren, Pa.	150
Duck Creek, Dodge City, Kans.	500	Tributaries of Monongahela River, Uniontown, Pa.	200
Minnesota River, Wellington, Kans. ...	200	Clarion River, Clarion, Pa.	200
Little Blue River, Eldorado, Kans.	500	Mill Pond, Driftwood, Pa.	100
Cow Creek, Wilson, Kans.	200	Clearfield Creek, Cresson, Pa.	300
Bull Creek, Paoli, Kans.	50	Red Bank Creek, Brookville, Pa.	200
Spillman Creek, Lincoln, Kans.	200	Two Lick Creek, Indiana, Pa.	200
Applicants in Kansas	3,975	Mahoning Creek, Punxsutawney, Pa. ...	200
Lake Ellerslie, Lexington, Ky.	200	Susquehanna River, Selinsgrove, Pa. ...	131
Rolling Fork of White River, Lebanon, Ky.	460	Conodoquinot Creek, Carlisle, Pa.	300
Salt River at Crooks Station, Ky.	100	Susquehanna River, Shickshinny, Pa. ...	131
South Licking River, Cynthiana, Ky. ...	550	Allegheny River, Tidioute, Pa.	150
Green River, Greensburg, Ky.	200	Muddy Creek, Carmichael, Pa.	200
Tygart Creek, Olive Hill, Ky.	500	Applicants in Pennsylvania	638
Hickman Creek, Lexington, Ky.	600	Chapman Pond, Westerly, R. I.	800
Crystal Lake, Covington, Ky.	300	Lilly Pond, Newport, R. I.	515
Lynn Camp Creek, Corbin, Ky.	600	Yorckes Pond, Kingston, R. I.	400
Brashear Creek, Shelbyville, Ky.	100	Pawcatuck River, Westerly, R. I.	2,000
Southside Lake, St. Charles, Ky.	100	Edisto River, Jacksonboro, S. C.	100
Applicants in Kentucky	1,875	Reservoir at Sheldon, S. C.	200
Forbes Pond, Sullivan, Me.	500	Congaree and Gill creeks, Columbia, S. C.	500
Lake Ellerslie, Upper Marlboro, Md. ...	200	Applicants in South Carolina	1,800
Youghiogheny River, Oakland, Md.	500	Big Sioux River, Canton, S. Dak.	100
Patuxent River, Sandy Springs, Md.	300	James River, Mitchell, S. Dak.	50
Potomac River, Hancock, Md.	1,000	Vermilion River, Centerville, S. Dak. ...	100
Potomac River, Lexington, Md.	1,000	Vermilion River, Vermilion, S. Dak. ...	100

REPORT OF COMMISSIONER OF FISH AND FISHERIES. LXXXIX

Details of distribution—Continued.

Species and disposition.	Adults and year-lings.	Species and disposition.	Adults and year-lings.
<i>Black bass, large-mouth—Continued.</i>		<i>Black bass, small-mouth:</i>	
Sioux River, Dell Rapids, S. Dak.....	100	Spectacle Pond, Sandwich, Mass.....	1,300
Sioux River, Sioux Falls, S. Dak.....	150	Big Sandy Pond, Buzzards Bay, Mass.....	500
Applicants in South Dakota.....	475	Applicants in Ohio.....	31
Oconee River, Parksville, Tenn.....	150	Potomac River, Great Cacapon, W. Va.....	888
Little River, Notime, Tenn.....	150	Total.....	2,719
Duck River, Columbia, Tenn.....	350		
Sequachee River, Sequachee, Tenn.....	100	<i>Crappie:</i>	
Smith Fork and Dry Creek, Water-town, Tenn.....	200	Fox River, McHenry, Ill.....	200
Big Pigeon River, Newport, Tenn.....	100	Wabash Railroad Pond, Pittsfield Junction, Ill.....	25
Big Flat Creek, Luttrell, Tenn.....	75	Applicants in Illinois.....	50
Applicants in Tennessee.....	625	Lake Maxinkuckee, Marmont, Ind.....	1,900
Lake McDonald, Austin, Tex.....	900	Iowa River, Iowa City, Iowa.....	125
Russell Creek, Miami, Tex.....	200	Applicants in Mississippi.....	50
Lee Creek, Miami, Tex.....	300	Big Harpeth River, Franklin, Tenn.....	200
Shelton Mill Pond, Athens, Tex.....	150	Sequachee River, Sequachee, Tenn.....	200
Kidd Springs Lake, Dallas, Tex.....	200	Applicants in Tennessee.....	75
Reservoir, Brownwood, Tex.....	200	Applicants in Virginia.....	50
Clear Fork of Trinity River, Fort Worth, Tex.....	200	Total.....	†2,875
McDonald Lake, Neches, Tex.....	300		
Spring Creek, Amarillo, Tex.....	300	<i>Rock bass:</i>	
West Amarillo Creek, Amarillo, Tex.....	300	Buck Creek Mill Pond, Dadeville, Ala.....	50
Crystal Lake, Palestine, Tex.....	300	Mill Creek, Dixons Mills, Ala.....	200
Spring Creek, Miami, Tex.....	200	Applicants in Alabama.....	725
Lake View, Brownwood, Tex.....	200	Applicants in Arizona.....	300
Highland Lake, Marshall, Tex.....	400	Auchita River, Arkadelphia, Ark.....	500
Wendomoyer Lake, Waco, Tex.....	500	Applicants in Arkansas.....	150
Elm Lake, Cameron, Tex.....	200	Applicants in Colorado.....	200
Lee Creek, Marshall, Tex.....	200	Chautauqua Lake, Lithia Springs, Ga.....	100
Highland Lake, Fairbank, Tex.....	200	Lake Wildwood, Columbus, Ga.....	75
Doudy Lakes, Hutchins, Tex.....	900	Little Swift Creek, Higgston, Ga.....	100
Mendow Brook Farm Lake, Waco, Tex.....	500	Little River, Washington, Ga.....	100
Lake Eloise, Waco, Tex.....	500	Applicants in Georgia.....	1,925
Wood Lake, Marshall, Tex.....	200	Applicants in Illinois.....	100
Marcado Creek, Victoria, Tex.....	500	Applicants in Indiana, at Raub.....	65
Hillsboro Park Lake, Hillsboro, Tex.....	500	Applicants in Indian Territory.....	300
City Lake, Ennis, Tex.....	500	Crane Creek, Chester, Iowa.....	200
Fountain Lake, Waco, Tex.....	400	State Fish Commission, Spirit Lake, Iowa.....	500
Silver Lake, Arlington, Tex.....	400	Applicants in Iowa.....	300
Dallas Fishing Club Lake, Hutchins, Tex.....	500	Forest Lake, Bonner Springs, Kans.....	300
Palestine Fishing Club Lake, Palestine, Tex.....	200	Spring Creek, Jetmore, Kans.....	100
Applicants in Texas.....	8,950	Buckner Creek, Jetmore, Kans.....	300
Derby Pond, Derby, Vt.....	200	Hull Creek, Paola, Kans.....	100
Derby Pond, Newport, Vt.....	500	Middle Creek, Ottawa, Kans.....	200
Salem Pond, Newport, Vt.....	500	Applicants in Kansas.....	5,525
Pigg River, Sandy Lovel, Va.....	200	Lake Ellerslie, Lexington, Ky.....	200
Cow Pasture River, Millboro, Va.....	600	Middle Fork of Rock Castle River, Livingston, Ky.....	200
Rappahannock River, Horners, Va.....	400	Applicants in Kentucky.....	1,135
Buffalo Creek, Lexington, Va.....	200	Patuxent River, Sandy Springs, Md.....	200
Dan River and tributaries, Danville, Va.....	400	Applicants in Maryland.....	750
Tye River, Massies Mills, Va.....	200	Twin Sisters Lake, Canton, Miss.....	50
South Mayo, Martinsville, Va.....	200	Applicants in Mississippi.....	2,092
Marrowbone Creek, Martinsville, Va.....	200	Morgan Springs, Osceola, Mo.....	500
Lake Drummond, Drummond Lake, Va.....	700	Indian Creek, near Neosho, Mo.....	250
Shenandoah River, Riverton, Va.....	500	Reservoir, Moberly, Mo.....	200
Rappahannock River, Elkwood, Va.....	400	Applicants in Missouri.....	1,100
Jackson River, Cedar Creek, Va.....	400	Lodge Pole Pond, Sydney, Nebr.....	500
Rappahannock River, Warrenton, Va.....	400	Applicants in Nebraska.....	90
Powell Run, Freestone, Va.....	200	Cedar Lake, Blairtown, N. J.....	90
Little River, Dover, Va.....	1,075	Bridgewood Lake, Lucaston, N. J.....	180
Reed Creek, Wytheville, Va.....	500	Reservoir, Pardy, N. Y.....	200
James River, Balcony Falls, Va.....	1,000	Mill Pond, Stokesdale, N. C.....	200
Gresham Pond, Reams Station, Va.....	800	Granite Falls Pond, Hickory, N. C.....	100
Applicants in Virginia.....	2,400	Rocky Creek, Wilkesboro, N. C.....	1,000
Potomac River, Great Cacapon, W. Va.....	1,104	Applicants in North Carolina.....	100
Deepers Creek, Morgantown, W. Va.....	100	Park Lake, Columbus, Ohio.....	850
Greenbrier River, Hinton, W. Va.....	300	Applicants in Ohio.....	2,300
Gauley River, Camden on Gauley, W. Va.....	70	Applicants in Oklahoma.....	200
Applicants in West Virginia.....	400	Applicants in Pennsylvania.....	1,800
Lake Beulah, Lake Beulah, Wis.....	800	Applicants in South Carolina.....	200
Total.....	*85,358	Choteau Creek, Springfield, S. Dak.....	200
		Wall Lake, Sioux Falls, S. Dak.....	200
		Electric Light Pond, Rapid City, S. Dak.....	200
		Applicants in South Dakota.....	1,900

* Lost in transit, 2,974.

† Lost in transit, 543.

XC REPORT OF COMMISSIONER OF FISH AND FISHERIES.

Details of distribution—Continued.

Species and disposition.	Adults and yearlings.	Species and disposition.	Adults and yearlings.
<i>Rock bass</i> —Continued.		<i>Rock bass</i> —Continued.	
Mouse Creek, Mount Verd, Tenn.....	200	Applicants in Virginia.....	3,200
Pistol Creek, Maryville, Tenn.....	200	Big Stony Creek, Lowell, W. Va.....	40
Doe River, Elizabethton, Tenn.....	200	Applicants in West Virginia.....	100
Applicants in Tennessee.....	1,325	Total.....	* 42,687
Bipalanco Creek Lake, Channing, Tex.....	200	<i>Strawberry bass:</i>	
Mineva Creek, Channing, Tex.....	200	Duck Creek, Dodge City, Kans.....	1,000
Tomero Creek, Channing, Tex.....	200	Stillman Creek, Lincoln, Kans.....	150
Crystal Lake, Palestine, Tex.....	300	Applicants in Kansas.....	600
Punta de Ayna Creek, Channing, Tex.....	200	Reservoir, Moberly, Mo.....	300
Silver Lake, Pittsburg, Tex.....	100	Applicants in Missouri.....	329
Zimmerman Lake, Washburn, Tex.....	120	Total.....	12,379
Applicants in Texas.....	5,800		
Clinch River, Tazewell, Va.....	200		
Rappahannock River, Elkwood, Va.....	200		
Ocotink River, Fairfax, Va.....	200		

Species and disposition.	Fry and fingerlings.	Species and disposition.	Fry and fingerlings.
<i>Codfish:</i>		<i>Lobster</i> —Continued.	
Vineyard Sound, Woods Hole, Mass.....	10,231,000	Casco Bay, off Jaquish Island, Me.....	2,050,000
Vineyard Sound, west from Quicks Hole Buoy, Mass.....	3,327,000	Gulf of Maine, off Richmonds Island, Me.....	500,000
Gloucester Harbor, Mass.....	4,097,000	Kittery Point Harbor, Kittery Point, Me.....	1,100,000
Atlantic Ocean, Gloucester, Mass.....	3,020,000	Muscle Ridge Sound, off Muscle Ridge Island, Me.....	1,840,000
Atlantic Ocean—		Harpwell Sound, between Harpwell Harbor and Reeds Cove, Me.....	200,000
Southwest of No Man's Land, Mass.....	4,075,000	Atlantic Ocean, between Portland and Orr Island, Me.....	300,000
Off Browns Ledge, Mass.....	4,282,000	Atlantic Ocean, off Monhegan Island, Me.....	1,225,000
Off Eastern Point, Mass.....	31,591,000	Atlantic Ocean, off Cape Elizabeth, Me.....	1,200,000
Gay Head Light House, Mass.....	9,877,000	Atlantic Ocean, off Matinicus Isle, Me.....	2,750,000
Off Thatcher Island, Mass.....	13,886,000	Harpwell Sound, off Stovers Point, Me.....	24,360
Off Devils Bridge Buoy, Mass.....	2,034,000	Casco Bay, off Marsh Island, Me.....	1,000,000
Boston Bay, off Baker Island, Mass.....	2,459,000	Woods Hole Harbor, Woods Hole, Mass.....	2,332,000
Boston Bay, off Eastern Point, Mass.....	3,042,000	Vineyard Sound.....	15,921,000
Atlantic Ocean, Vineyard Sound, Mass.....	1,527,000	Vineyard Sound, Gosnold, Mass.....	7,200,000
Massachusetts Bay, off Baker Island, Mass.....	4,210,000	Vineyard Sound, North Tisbury.....	3,687,000
Total.....	98,258,000	Vineyard Sound, Gay Head, Mass.....	1,710,000
<i>Flatfish:</i>		Buzzards Bay, Gosnold, Mass.....	9,024,000
Woods Hole Harbor.....	53,993,000	Buzzards Bay, South Dartmouth.....	3,210,000
Waquoit Bay, Waquoit, Mass.....	10,102,000	Buzzards Bay, Quissett, Mass.....	4,009,000
Total.....	64,095,000	Buzzards Bay, Woods Hole, Mass.....	3,705,000
<i>Tautog:</i>		Buzzards Bay, New Bedford, Mass.....	1,847,000
Woods Hole Harbor.....	287,000	Plymouth Bay, Plymouth, Mass.....	931,000
Barnyard Sound, Woods Hole.....	242,000	Massachusetts Bay—	
Vineyard Sound, Gosnold, Mass.....	52,000	Off Salem, Mass.....	250,000
Buzzards Bay, Quissett, Mass.....	43,000	Off Gloucester, Mass.....	15,710,000
Total.....	624,000	Off Manchester, Mass.....	345,000
<i>Maackerel:</i>		Off Marblehead, Mass.....	5,245,000
Massachusetts Bay, off Gloucester, Mass.....	588,000	Off Magnolia, Mass.....	2,010,000
Massachusetts Bay, Magnolia, Mass.....	64,000	Southeast of Cape Ann, Mass.....	100,000
Total.....	652,000	Southeast of Great Eastern Point, Mass.....	241,705
<i>Sea bass:</i>		Off Halfway Rock, Mass.....	1,225,000
Barnyard Sound, Woods Hole.....	193,000	Atlantic Ocean, off Rockport, Mass.....	3,620,000
<i>Lobster:</i>		Atlantic Ocean, off Gloucester, Mass.....	4,830,000
Fisher Island Sound, Noank, Conn.....	1,248,000	Atlantic Ocean, off Vineyard Light-ship, Mass.....	309,000
Fisher Island Sound, Stonington, Conn.....	980,000	Provincetown Harbor, Provincetown, Mass.....	1,877,000
York Harbor, York, Me.....	500,000	Plymouth Harbor.....	1,072,000
Casco Bay, off Brown Cow Island.....	1,500,000	Barnstable Bay, Sagamore, Mass.....	1,016,000
Casco Bay, off Brown Bull Island.....	150,000	Gloucester Harbor, Gloucester, Mass.....	2,969,000
Casco Bay, between Mark Island and Bald Head, Me.....	100,000	Narragansett Bay, Newport, R. I.....	2,564,000
Casco Bay, between Mark Island and Flag Island, Me.....	350,000	Total.....	115,606,065

* Lost in transit, 6,938.

† Lost on route, 750

; Lost en route, 1,208,000 fry.

REPORT OF THE DIVISION OF SCIENTIFIC INQUIRY.

BY HUGH M. SMITH, *Assistant in Charge.*

Up to December 31, 1896, this division was under the charge of Mr. Richard Rathbun, who resigned to take effect on that date, when Dr. Hugh M. Smith was appointed to the vacancy. Other changes in the personnel of the division consisted in the promotion of Dr. H. F. Moore, scientific assistant, to the position of naturalist on the steamer *Albatross*, vice Mr. Charles H. Townsend, appointed assistant in charge of Division of Fisheries, and Mr. F. M. Chamberlain, scientific assistant, promoted to the position of general assistant on *Albatross*, vice H. B. Miller, deceased. Mr. M. C. Marsh, of Cornell University, was appointed a scientific assistant in conformity with civil-service regulations.

FIELD INVESTIGATIONS.

During the year numerous field inquiries were conducted in different parts of the country. Besides the usual investigations of fishes of the interior waters, which have been regularly carried on for a long series of years, many special inquiries of a diverse character were undertaken.

Extensive investigations in the waters of Idaho, Washington, and Oregon were prosecuted. These had for their object the study of the distribution, abundance, habits, and spawning of the salmon, trout, and other native fishes; the examination of various lakes with reference to the introduction of the common eastern whitefish, and the survey of streams with a view to ascertain their advantages and facilities for fish-cultural operations. The investigations were in immediate charge of Prof. Barton W. Evermann, who was assisted by Mr. A. B. Alexander, Dr. Seth E. Meek, Prof. Ulysses O. Cox, and Mr. A. G. Maddren.

A systematic examination of the short coast rivers of the Pacific Coast from San Francisco northward was begun. A number of interesting inquiries in Florida, Mississippi, Louisiana, and Texas were made pursuant to special requests.

Outlines of the more important inquiries are here given. Detailed accounts of some of them will be found in special printed reports.

LOWER COLUMBIA RIVER BASIN.

It being the intention of the Commission to establish a salmon hatchery on one of the tributaries of the Columbia River, in order to supplement the fish-cultural operations of the hatchery on Clackamas River, extensive investigations were made in August and September.

The streams visited were Lewis, Toutle, Hood, Big White Salmon, Little White Salmon, Des Chutes, and John Day rivers; the Columbia River at the Cascades and Celilo; Hamilton and Rock creeks near the Cascades, and Tanner and Eagle creeks.

The examinations were in the main limited to the lower parts of the streams on account of their greater accessibility, a reasonably close proximity to the railroad being a desirable feature of the proposed station. During the visits made to these streams early in August the inquiries consisted chiefly in determining their physical characters, the examination of possible sites for hatchery buildings, and the collection of information concerning the abundance of salmon. At that time the run of fish had not begun, and no authentic information regarding the spawning time and condition could be obtained. It was therefore necessary to revisit the different localities in September, when salmon were arriving upon the spawning-beds and it was possible by personal observation to determine the relative advantages of the different sites and streams for fish cultural purposes.

Salmon were found in some numbers in Big White Salmon and Little White Salmon rivers and in Tanner and Eagle creeks. No salmon were observed in Des Chutes, John Day, and Hood rivers, and it is doubtful whether, at the present time, these rivers contain any important spawning-grounds of the chinook salmon. Salmon were observed in greatest abundance in Little White Salmon River, and this stream was selected as the most desirable site for the contemplated hatching-station. Temporary buildings were hastily constructed and the station operated during the same fall. The number of eggs collected was comparatively large and warrants the belief that this is one of the best sites in the lower Columbia basin for fish-cultural work.

In September and October, 1896, Mr. A. B. Alexander spent considerable time at the canneries of Mr. I. H. Taffe and Messrs. Seufert Bros., at Celilo, Oreg., inspecting the catch of salmon made in their wheels and nets. Important data were obtained as to the relative abundance of chinook salmon, silver salmon, and steelheads, their sizes, spawning condition, relative numbers as to sex, and the time of run.

WALLOWA LAKE, OREGON.

A brief visit was made to this lake in August, 1896, by Messrs. Meek and Maddren for the purpose of ascertaining what facilities existed in that region for the study of the blueback salmon or redfish and the quinnat salmon, more especially their spawning habits and grounds and their condition after spawning. No large redfish were seen, but it was learned that this species formerly spawned in large numbers in an inlet of Wallowa Lake; the run has been rapidly decreasing in recent years. This region is also a spawning-ground of the small redfish, but they had not arrived at the time of this visit. Important spawning-grounds of the chinook salmon formerly existed in the west and main forks of Wallowa River, but during the last few years not many of this species have been seen.

LAKE PEND D'OREILLE, IDAHO.

The investigations begun on this lake in the latter part of June, 1896, by Messrs. Alexander and Cox were continued until July 16, when the requirements of the work on Puget Sound necessitated the suspension of the inquiries. The visit to this lake had for its object the search for survivors of the plant of whitefish made by the Commission in 1889, and the determination of the physical characters and the nature of the aquatic fauna. The results of the inquiries were not altogether satisfactory, owing to the shortness of the time devoted to them and to the unfavorable conditions then prevailing. The melting snows and heavy rains caused the water in the lake to rise from 10 to 17 feet higher than normal, and retarded the work.

An abundance of small crustaceans and insect larvæ suitable for fish-food was found, and the indications are that the lake is well adapted to the common whitefish. Although no specimens of this species were seen, and no reliable evidence was obtained showing that it has succeeded in establishing itself, further inquiries will be necessary in order to settle the matter conclusively. A party could profitably devote an entire summer and fall to an examination of this important lake.

THE REDFISH LAKES, IDAHO.

The studies of the spawning habits of the redfish or blueback salmon and the chinook salmon begun in these lakes in 1894 and continued in 1895 were resumed in the present year by Messrs. Evermann, Meek, and Maddren. The observations were confined chiefly to Alturas Lake, its inlet and outlet, and the upper course of Salmon River, although some examinations were made at Pettit and Big Redfish lakes. The work began July 10 and continued until October 5, the observations after August 15 being made by Mr. F. C. Parks, of Sawtooth, Idaho.

Among the most important facts established by the investigations of 1895 were the following: (1) Both the redfish and the chinook salmon reach these spawning-grounds in excellent condition, showing no mutilations or sores of any kind; the mutilations appear later, and are due to injuries received on the spawning-beds. (2) All of the fish of these two species coming to the headwaters of Salmon River for spawning purposes die immediately after spawning. (3) The young of each of these species remain in the vicinity of the spawning-beds for about one year. (4) The eggs of the redfish laid in September hatch in the following March.

The inquiries carried on in 1896 were, in the main, a repetition of those of 1895, and resulted in a complete verification of the more important points established that year. The season was unfavorable, however, for the study of the chinook salmon and the large redfish; only a few of the former and none of the latter were seen. This is doubtless to be attributed, in part at least, to their wanton destruction in these waters by men and boys. The small redfish were even more numerous than

in 1895. Upward of 2,000 were observed on their spawning-ground in the inlet to Alturas Lake. They were closely watched through the season and it was found that all died at the close of the spawning period. These fish were already in Alturas Lake when the observations began, July 10, and it is not yet certainly known whether they are anadromous or remain permanently in the lake.

TRIBUTARIES OF PUGET SOUND.

In 1889 a large plant of fry of the eastern whitefish (*Coregonus clupeiformis*) was made in Lake Washington, near Seattle, by the United States Fish Commission. In June, 1896, Mr. A. B. Alexander devoted a short time to a series of examinations to determine whether any of these fry have survived. No whitefish were found. Investigations were again taken up in November and December, 1896. Various tests were made with appropriate kinds of apparatus in different parts of the lake, but no evidence was obtained that any of the whitefish remained. The physical features of the lake were carefully studied, soundings were made, a valuable series of temperature observations was recorded, and collections of the fishes, crustaceans, and other inhabitants of the lake were obtained.

Connected with Lake Washington, and distant only a few miles, are Lakes Union and Sammamish. Mr. Alexander conducted similar investigations in these waters, studying the physical conditions and making collections of the fishes and crustaceans.

During July and August, 1896, Messrs. Alexander and Cox carried on studies of the blueback or sockeye salmon (*Oncorhynchus nerka*) in certain streams flowing into Puget Sound from the east. One object of the investigation was to obtain information desired by the International Joint Fishery Commission as to whether any large numbers of blueback salmon entering Puget Sound ascend Washington rivers for the purposes of spawning. The movements of the bluebacks in the region of the San Juan Islands were studied, and the more important rivers were visited and examined, among them being the Skagit, Nooksack, and Stilligumish. It was ascertained that the blueback enters only the Skagit River in noteworthy numbers, and that important spawning-beds occur in Baker Lake and Baker River, one of the principal tributaries of the Skagit.

TSILTCOOS, WHOAHINK, AND TAHKENITCH LAKES, OREGON.

These are small lakes situated near the coast a few miles south of the mouth of the Siuslaw River. A number of persons living in the vicinity had requested the Commission to stock Tsiltcoos Lake with black bass and Whoahink Lake with brook trout. Dr. Meek, who was engaged in experimental fish-cultural work on the Siuslaw River, was detailed to report on the advisability of complying with the requests. The biological and physical features of the lakes were studied and large collections were made of the native fishes and the various kinds

of fish-food found. It was learned that a considerable number of salmon run into one or more of these lakes; and that all of them, but particularly Whoahink, are well supplied with the native black-spotted trout, which attains a large size and possesses excellent game qualities. The planting of black bass in Tsiltcoos Lake would, in all probability, prove detrimental to the native trout and the salmon, while the eastern brook trout would probably never become so well established as to render these lakes more attractive to anglers than they now are.

UPPER KLAMATH LAKE, OREGON.

In 1889 the Fish Commission planted 400,000 fry of the common whitefish (*Coregonus clupeiformis*) in Upper Klamath Lake. Sufficient time having elapsed to enable the species to become established if the conditions were favorable, investigations were made to determine the result of the plant. Messrs. Meek and Alexander reached the lake October 31, and continued their observations until November 7. The parts of the lake which were most carefully examined were Pelican Bay and vicinity, and the extreme southern end, near Klamath Falls. The lake was found to be comparatively shallow, the greatest depth in the places where soundings were taken being 17 feet, while the usual depth did not exceed 6 or 7 feet. The bottom consists largely of a loose layer of decaying vegetation from the extensive tule marshes adjoining the lake. Fish-food, chiefly small crustaceans and insect larvæ, was found to be very plentiful. Trials were made with seines, gill nets, set lines, and other apparatus, but no whitefish were taken, nor did inquiry among the people on the shores of the lakes elicit any information showing that the fry have survived. The general physical characteristics of the lake hardly warrant the expectation that the common whitefish can be acclimatized.

The lake is, however, well supplied with one of the largest and best species of American trout. It attains a weight of 17 pounds and is easily captured by trolling, and is so abundant as to attract many anglers to the lake each season. The lake is also inhabited by four or five species of suckers, several of which are exceedingly numerous, of large size, and constitute an important part of the food supply of the Indians upon the Klamath Reservation.

CRATER LAKE, OREGON.

In response to the request of citizens of Klamath Falls, Ashland, and Medford, Oreg., and of the Mazamas, an association of mountain climbers with headquarters at Portland, Oreg., the Commission sent Messrs. Evermann and Cox to Crater Lake to determine whether it was advisable to plant trout in the lake, which now contains no fish whatever. Six days in August were devoted to an examination of the physical and biological features of the lake.

This lake is on the crest of the Cascade Mountains, about 100 miles east of Ashland. It is unique in character and ranks among the most

wonderful of the natural attractions of America. It is approximately circular in shape and about 5 miles in diameter. It lies in the top of Mount Mazama, and is completely encircled by a bold escarpment rising from 500 to 2,000 feet almost vertically from the water's edge. So steep are the walls that in only a few places is it possible to descend to the lake. Crater Lake is the deepest American lake, and one of the deepest in the world. The greatest ascertained depth is 2,000 feet, a large part of the bottom being practically a level floor of this depth. With a few limited exceptions there is practically no shore and scarcely any shallow water, the surrounding walls extending vertically beneath the water to a depth of several hundred feet. In Eagle Cove on the south side of the lake, in Cleatwood Cove on the north side, and about Wizard Island are found the only considerable areas of shallow water, the depth ranging from 2 to 100 feet; and, in the absence of streams flowing into the lake, the best conditions required for spawning-beds would probably be furnished at these places.

The water was ascertained to be sufficiently pure and of proper temperature for trout, and to contain a fairly abundant supply of fish-food, consisting chiefly of small crustaceans, insect larvæ, and mollusks. While the conditions do not seem favorable for the existence of an abundant fish life in this lake, it is probable that a limited number of trout would be able to maintain themselves in it, especially the species of black-spotted trout found in Lake Tahoe (*Salmo mykiss henshawi*).

COAST RIVERS OF CALIFORNIA.

In May, 1897, Dr. Charles H. Gilbert, with four assistants from Leland Stanford Junior University, was engaged to make an ichthyological canvass of the coastal streams of California, and at the close of the year the inquiry was still in progress. The object of the investigation was to study the fishes of the different streams with reference to their distribution, abundance, spawning habits and grounds, etc., particular attention being paid to the species of economic value.

FLORIDA.

In October and November, 1896, certain investigations were carried on in the coastal waters of Florida in response to a resolution of the United States Senate, dated February 15, 1895, requiring the Commissioner to make an inquiry as to the extent, methods, and present condition of the coast fisheries of the State, especially the sponge and oyster fisheries. Prof. B. W. Evermann and Dr. W. C. Kendall represented this division in the party sent by the Commissioner to make the necessary examinations. Special inquiries were made at Key West, Biscayne Bay, Tampa, Tarpon Springs, and other places, having for their object a study of the natural history of the various species of commercial sponges with reference to the causes of the decrease in their abundance and the possibilities of artificial propagation; also a deter-

mination of the abundance, size, spawning, food, etc., of the commercial salt-water fishes.

The sponge industry received much attention. It was ascertained that the methods employed are seriously affecting the permanency of the industry and that important modifications in the regulations governing this fishery are much needed. The inquiries led to the view that the lawful minimum size of sponges should be increased, the law forbidding the sale of undersized sponges should be enforced, arrangements should be brought about by which any given ground should be fished over only once in any period of two years, and provision should be made for the protection of those desiring to undertake the artificial propagation of sponges, a new field that gives promise of results of great economic importance.

The number of species of salt-water food-fishes in Florida is perhaps larger than in any other State. The fishes are especially numerous, as regards both individuals and species, among the Florida Keys. The species handled for food at Key West exceed 100, many of which are of much commercial importance. If to these are added those of no direct food value, the total number of fishes inhabiting the Key West region is found to be about 225. The investigations indicate that there has been no noteworthy diminution in the abundance of any of the food-fishes of this part of the State. The present methods followed in fishing are such as will conserve the fisheries to the fullest extent. While much information was obtained regarding the fishes, there is yet a great deal to be learned. The fishermen are, as a rule, poorly informed on the habits and spawning of even the common species, and their opinions can not be relied on. The most satisfactory way to gain a knowledge of the life-histories of these fishes is to station at Key West a trained observer, who will continue his observations during one or two entire seasons.

Large and important collections of fishes were made at the different places visited. These are now being studied, and will, in conjunction with other collections from Florida, serve as the basis for a comprehensive report on the fishes of the State. The general information collected was utilized in a report submitted to the Senate by the Commissioner in January, 1897.

MISSISSIPPI.

At the request of prominent citizens of New Orleans, an examination of certain waters about the mouth of Pearl River, Mississippi, was made in April, 1897, for the purpose of determining if anything could be done to increase the abundance of game and food fishes in that region. The locality is an important resort for New Orleans anglers, who are desirous that additional species of game fishes be introduced if the waters should prove suitable. The examinations, which were conducted by Messrs. B. W. Evermann, H. R. Center, and F. M. Chamberlain, were

carried on chiefly in the vicinity of Baldwin Lodge, located on Campbell Bayou. The water in this locality consists of two mouths of Pearl River and a large number of lagoons, bayous, and lakes. At the time of the visit these waters were almost fresh, being slightly brackish only in the portions nearest the Gulf of Mexico. During the dry season, however, it is likely that brackish water extends several miles above Baldwin Lodge. The lagoons and lakes are shallow, and the water in summer doubtless becomes quite warm. In April the temperature at the surface was found to vary from 68° to 76°, and at the bottom, in 10 feet of water, was 65°.

The large-mouthed black bass (*Micropterus salmoides*) is the principal fresh-water game fish in this region, though the goggle-eye (*Chenobryttus gulosus*) and several other species of sunfishes and catfishes are also abundant. During the dry season various salt-water fishes, such as sheepshead, redfish, drum, etc., appear in large numbers. The fishes which can be introduced into these waters to the best advantage are the crappie and the calico bass. It is very probable that both of these would thrive very well in the lagoons, lakes, and channels farthest from the Gulf.

SOUTHEASTERN TEXAS.

In the latter part of April a few days were spent by Messrs. Evermann and Chamberlain on the Sabine and Neches rivers, in southeastern Texas, for the purpose of determining whether these streams are suitable for stocking with shad. Inquiries were conducted at Orange, Beaumont, Lufkin, and Logansport. Considerable collections of fishes were obtained at these places, and inquiries were made of various people acquainted with the rivers, but no evidence was obtained indicating that the shad planted here several years ago have ever been seen since. The character of these streams does not indicate that they would prove suitable for shad. The water would probably be so muddy during the spawning season as to prove fatal to a large percentage of the eggs and fry.

LOUISIANA.

It having been represented to the Commission that the catch of catfish in the Atchafalaya River, Louisiana, has been rapidly decreasing during the last two or three years, a brief investigation was made during the latter part of April, 1897, to determine the cause of the decrease and the remedy therefor. The inquiries were carried on by Messrs. B. W. Evermann, F. M. Chamberlain, and H. R. Center.

The catfish industry of the Atchafalaya River centers chiefly at Morgan City, and is a very important one, the three firms doing business there shipping more than a million pounds of dressed fish annually.

During ordinary stages of water the fishing is prosecuted chiefly in the regular waterways or channels, and set lines of various lengths are used; but when the country becomes flooded in spring, the fishing is done in the woods. Instead of trot lines, a single short line is used,

one end of which is tied to a limb and the other allowed to hang 12 to 18 inches under water. The hooks are baited with "shad" (*Hiodon, Dorosoma, Signalosa*, etc.) or crawfish. The fisherman visits his lines twice a day if possible, takes the fish off the hooks and puts them in live-boxes, where he keeps them until the collecting tug from the company to which he sells comes along. The fish are then transferred to the live-cars of the tug and towed to Morgan City. The Morgan City tugs ascend the Atchafalaya River and its connecting lakes and bayous for 75 to 100 miles north of Morgan City. When the fish are brought to Morgan City, they are dressed, barreled in ice, and shipped to various points in Texas, Indian Territory, Kansas, Colorado, and elsewhere west and northwest. The principal species handled are the blue cat (*Ictalurus furcatus*) and the goujon or yellow cat (*Leptops olivaris*). A small percentage of the catch consists of the spotted or channel cat (*Ictalurus punctatus*) and the eel cat (*Ictalurus anguilla*).

The blue cat and the goujon reach a very large size. Formerly individuals of each weighing 75 to 110 pounds were not infrequent, but now one weighing more than 50 pounds is not often seen. The flesh of these fish is of excellent flavor and finds a ready sale wherever its good qualities are known.

The statistical inquiry very soon developed the fact that there has been a very great decrease in the catch during the last few years, and a careful inspection of the fish in the live-boxes of the fishermen and again in the companies' houses at Morgan City suggested the causes for the decrease. Overfishing and fishing during the spawning season are doubtless the principal causes.

A law fixing a minimum size of the fish which it is lawful to sell, and a close season during the height of the spawning period, would doubtless do much toward the rebuilding of the industry.

During the inquiries valuable collections of the different species of catfishes and other fishes of the region were made.

LAKE SUPERIOR.

In April, 1897, Mr. A. J. Woolman was detailed to make some inquiries in Lake Superior during the subsequent spring and summer months, relative to the food of the principal fishes found in the lake, including the common whitefish, the lake herring, other species of whitefishes, the lake trout, the siscowet, the wall-eyed pike, and the sturgeon. Besides enumerating the food-objects of each species, the inquiries were intended to bring out the variations in the character of the food dependent on age, size, season, spawning condition, etc.; the distribution, abundance, and habits of the food-organisms were also topics to be studied. A knowledge of the food of the predaceous species involves a study of the food of the fishes on which they subsist, and the investigation is therefore thrown back on a study of the minute life of the lake, the most important forms probably being the entomostraca.

The consideration of the food of very young fishes received special attention because of its bearing on fish-cultural work. It is important to determine whether the places in which whitefish and other fry are planted are provided with suitable food-organisms; and if not, the inquiries were intended to show the most favorable localities for the liberation of young fish. By the close of the fiscal year the work was progressing satisfactorily and gave evidence of important practical results.

STUDIES OF YOUNG FISH.

During the year some important studies of the movements, habits, food, growth, etc., of young shad and Pacific salmon were begun, and resulted in a considerable addition to existing knowledge. These will be extended so as to embrace most of the fishes cultivated by the Commission.

In association with the work of propagating shad on the steamer *Fish Hawk* in St. Johns River, Florida, in January and February, 1897, Dr. W. C. Kendall was detailed to conduct systematic observations relative to young shad in that stream. Later he accompanied the vessel to Albemarle Sound, North Carolina, and continued his inquiries in that region. On the completion of the shad-hatching there in March, the investigations were transferred to Potomac River, where arrangements were made for an active study of the young fish during the following months, at a number of points on fresh, brackish, and salt water.

In February, 1897, Mr. A. B. Alexander, fishery expert of the *Albatross*, was detailed to make studies of the movements and habits of young quinnat salmon. The Commission had under consideration the advisability of liberating artificially hatched salmon fry at points near salt water, instead of in the upper courses of the streams where they are naturally hatched, in order that they may have a better chance of escaping from their numerous enemies in the rivers and reaching the ocean. The tributaries of Tomales Bay, California, were selected for the experiments and observations. About 700,000 recently hatched fish were transferred to Olema, on a tributary of the bay, and were subsequently distributed in suitable lots to Bear Valley Creek, Paper Mill Creek, Dutch Bill Creek, and Olema Creek. Mr. Alexander began his observations on February 25 and continued till April 1, when he was relieved by Mr. N. B. Scofield, of Leland Stanford Junior University, who was employed until May 20. The inquiries consisted in noting the behavior of the young fish after planting; their movements to and from the salt water; their growth, food, and enemies; the influence of temperature and rains on their movements; and the length of their sojourn in the creeks.

The Tomales Bay region is made up of low lines of hills running north and south, barren on their western slopes, but heavily wooded on their eastern side. The bay itself, which is quite shallow, 2 or 3 miles wide and 30 miles long, occupies the space between two ridges.

Towards its upper end, it gradually grows very shallow and at low tide leaves a large mud flat; at high tide the water backs up in Paper Mill Creek for about 3 miles. Paper Mill Creek and Olema Creek are favorite angling resorts. The two streams are much alike, but the former is larger. Its banks from tide water to the source are heavily wooded, keeping the water cool. The upper half has considerable fall and descends over rocky cascades, but there are no places that fish can not get over. There are many broad and quiet pools and places where the current runs through narrow channels between the rocks; there are also broad riffles where the water runs over gravelly beds. The stream is regarded as an ideal spawning-ground for the steelhead.

None of the creeks tributary to the bay becomes dry in summer; all are quickly swollen by rains, and quickly subside again.

The reports of Messrs. Alexander and Scofield show that up to the time of the discontinuance of the inquiries most of the young salmon planted were still in the streams. The observations showed that some of them at least had run into salt water and that they probably go out at intervals in small schools. The movements of the fish in the streams are regulated primarily by the food supply, which in its turn may be affected by temperature or rains. When the food supply grows short, the young fish instinctively move downstream. In the fresh water they show no tendency to congregate in schools. Their numbers in any given locality are determined by how many the place will accommodate and give each an equal chance to secure its food. They prefer to scatter and shift for themselves. Young salmon in tide water, especially those in brackish water, seem to move in schools.

The inquiries indicated that the salmon are not preyed on by any of the fish in these streams, and that the number caught by snakes and birds must be very small. In the systematic seining done to obtain specimens for comparison, all of the salmon taken were strong and robust, and apparently no place could have been better suited to their development. The few fish taken in salt water were healthy-looking and had been eating young smelt; there are large quantities of young smelt in the bay, which would probably form suitable food for the salmon, and are of a size adapted to their needs.

Before the planting of the young salmon, there were no fish of this species in these streams. This fact, combined with the circumstance that they have done so well, makes it an exceptionally fine opportunity to determine how long such fish will remain in the streams. A person stationed at Olema can easily observe the salmon in the streams named from their source to salt water. To get the best results, observations should be carried on at least a year. By engaging the services of some of the fishermen, and attaching a minnow-seine to the center of their nets, young salmon can be collected in the bay at intervals and many of their habits in salt water learned.

INVESTIGATIONS OF THE ALBATROSS.

COASTS OF CALIFORNIA AND WASHINGTON.

The recent marked development of the fisheries of southern California, more especially those carried on with lines for bottom fish like the rock-cods, made it desirable that the location, extent, and resources of the principal fishing-banks should be determined, and the *Albatross* was assigned to the work. About eight years ago the vessel spent a few months on a preliminary examination of the fishing-grounds off the southern coast of the State, but has done practically nothing of a like nature since that time. The grounds then surveyed were principally off Santa Barbara, Ventura, and San Diego counties. The territory selected for the present inquiry comprised grounds off Los Angeles and Orange counties, particularly the vicinity of Santa Catalina Island. The investigation, which was carried on during part of the month of April, was curtailed by the necessity of preparing the vessel for the inauguration of inquiries in Alaska about June 1. A renewal of this work is contemplated. The examination of the waters consisted of the usual hydrographic work and the setting of various appliances to show the abundance and nature of the animal life. Trials for fish were made with trawl lines, hand lines, deep-water gill nets, beam trawls, seines, and dip nets in combination with electric light.

On the way to San Francisco after the conclusion of the foregoing work the vessel spent a short time in setting deep-sea gill nets and beam trawls off Monterey Bay and in the vicinity of the Farallone Islands, with a view to ascertain the presence of salmon or other anadromous fishes. Similar experimental trials for salmon were made off Cape Flattery and in the Straits of Fuca as the vessel was on the voyage to Alaska.

A detailed account of the foregoing work will be found in Lieut. Commander Moser's report of the operations of the *Albatross*.

SOUTHEASTERN ALASKA.

In the spring of 1897 arrangements were made to have the *Albatross* visit southeastern Alaska for the purpose of conducting fishery investigations. The vessel started north from San Francisco on May 8, arrived in southeast Alaska on June 6, and immediately began inquiries.

The principal subjects determined on for investigation were the salmon industry and the halibut fishery. The magnitude of the salmon fishery in Alaska and the absence of accurate information concerning the various streams made it very desirable that the Commission should begin a systematic survey of the waters frequented by the salmon. This fishery is prosecuted along 3,000 miles of the Alaska coast. Inasmuch as the regulation of the fisheries of the Territory is vested in the general government, an important object of the investigation is to ascertain the conditions prevailing in the different sections, in order that suitable protective laws may be provided, since no general law will meet all the conditions or be applicable to all regions.

It is thought that two or three years will be required to complete this work, which was in active progress at the close of the year. The inquiries will extend to each stream in or near which fishing is done or in which salmon are found, and will relate to the physical characters of the stream; the species of salmon entering it, the time and duration of their run, their relative abundance; the spawning time, habits, and grounds of each species; natural and artificial obstructions to the passage of fish upstream; the methods of fishing in their relation to the maintenance of the supply; the general fish-fauna in each stream and its relations to salmon, and the extent of the fishing, canning, and salting business.

INQUIRIES AND EXPERIMENTS RELATIVE TO OYSTERS.

Among the questions of vital interest to oyster-growers in the United States are the following: (1) Under the prevailing economic conditions, is it possible to profitably fatten oysters in artificial ponds or claires? (2) Is it commercially practicable to breed oysters in ponds so as to furnish a supply of seed in regions where it can not be raised with regularity by the ordinary means now employed? These subjects the Commission had under consideration during the fiscal year, but it was not possible to take up both, owing to the limited force available for such inquiries. The question of the feasibility of breeding oysters in inclosed or semi-inclosed ponds was deferred for the present, and the matter of fattening oysters was taken up because of its more widespread and immediate importance.

Observation and inquiry have shown that in a number of localities planters have encountered yearly increasing difficulty in bringing their oysters to such a condition as to yield the best financial returns. This difficulty is especially manifested in regions in which there has been a heavy increase in the area of the planted beds, and is apparently due to the inadequacy of the water to support the luxuriant micro-vegetation which is necessary to supply oysters with food. The problem for the oyster-grower, therefore, is to increase the oyster-food-producing powers of the water. It is evident that this can not be undertaken to advantage in the open waters of bays and bayous in which the oysters are grown, and the question resolves itself into the feasibility of some method of pond culture. Recognizing this, experiments were begun in May, 1897, in Lynnhaven River, Virginia, under the charge of Dr. H. F. Moore. A cove having an area of over an acre was inclosed by a substantial dam, so as to exclude the tides, and three small ponds were constructed for the conduct of check experiments. Tests are being made, by varying the temperature, density, and the chemical composition of the water, to determine the most favorable conditions for the development of the microscopic organisms upon which the oysters feed. At the close of the fiscal year the actual experiments had been in operation but a short time and the results can not yet be stated.

During the year a paper entitled "Oysters and methods of oyster-culture" was prepared by Dr. Moore. It aims to bring together, for the information of oyster-growers, the more important facts relating to the life-history of the oyster, and to furnish to those lacking experience the information necessary to enable them to carry on successful oyster-culture.

There have been the usual complaints of the destruction of oysters in Long Island Sound by starfish, but this enemy is now less feared and more successfully combated than in former years. The tangle seems to be the most effective appliance used in its capture.

In April Mr. Fred Mather sent to this office specimens of a small crustacean which is said to feed upon the starfish. It is an isopod of the family *Cirolanida*, hitherto undescribed, and is the subject of a paper to be hereafter published.

In Long Island Sound, in various parts of New Jersey, and in some other localities there has been more or less trouble with "green gills." Late in the month of June a few affected oysters were observed in Lynnhaven River, and during the summer all of the beds were more or less affected. It is notable that oysters placed in the experimental claire were wholly untinged by the green coloration. After all that has been written on this subject it should be unnecessary to point out the vegetable origin and harmlessness of the "green gills," but there is still much reluctance on the part of consumers to purchase green oysters, great loss being thereby entailed upon the growers.

During May, 1897, it was reported in the press that the oyster set in the vicinity of New Haven was dying of a mysterious malady, but no complaints were received at this office. It is probable that this trouble was local and not serious, as the seed-growers in other parts of Long Island Sound appear to have had a very successful season.

The oyster season of 1896-97 is generally reported to have been unsatisfactory to the dredgers of Chesapeake Bay, owing in part to the depletion of the natural beds, and also, it is stated, on account of the competition of planted oysters, which each year are occupying a more important place in the markets. The conflict between the natural-bed and the planting interests of Delaware Bay has resulted in legal and legislative warfare in New Jersey, a contest which has been waged with more or less energy for several years. The net results of such disputes elsewhere has generally been to liberalize the laws relating to planting, in consequence of which that branch of the industry is exciting much interest. An evidence of this is seen in the increased sales of seed oysters in Connecticut during the spring of 1897 and in the purchase of seed in the Chesapeake region by the oystermen of New Jersey and Delaware.

During the spring of 1897 arrangements were made to have Prof. F. L. Washburn, of the University of Oregon, make a study of the bays of the west coast to determine those possessing conditions favorable to the introduction of the eastern oyster. At the end of the fiscal year

this investigation was in progress. In November, 1896, 25 barrels of eastern oysters were planted in Humboldt Bay, California, and an equal quantity in Yaquina Bay, Oregon. Both lots were planted under the immediate supervision of Mr. C. H. Townsend. Specimens of those planted at Yaquina Bay were received at this office during the summer and exhibit an encouraging growth, and those at Humboldt Bay are also reported to be doing well. It is still too soon to say whether self-perpetuating beds can be established at these places. No spat has yet been found in either place, but Professor Washburn reports copious spawning during the past summer.

INVESTIGATION OF CONTIGUOUS WATERS OF UNITED STATES AND CANADA.

Under the provisions of an agreement, dated December 6, 1892, between the Governments of Great Britain and the United States, having for its object the investigation of the fisheries in the waters adjacent to the American-Canadian boundary, Mr. Richard Rathbun, of the United States Fish Commission, and Dr. William Wakeham, of the Canadian Department of Marine and Fisheries, conducted extensive inquiries during the years 1893, 1894, 1895, and 1896, with the aid of assistants from the respective departments. On December 31, 1896, the commissioners submitted their report, which was transmitted by the President to Congress on February 24, 1897, and printed as House Document No. 315, Fifty-fourth Congress, second session.

The report deals fully with the conditions prevailing in each of the international waters involved in the agreement; considers the physical and ichthyological features; discusses the relations of the fisheries, of obstructions, and of pollutions to the fish supply; and makes numerous recommendations concerning the preservation of the fisheries. The mackerel fishery, to which much attention was given by the commissioners during the past four seasons, was not considered in the report.

In view of the magnitude of the fisheries covered by the investigations, and of the importance to the fishing interests of the conclusions reached by the commissioners, their general recommendations, as well as those for the different waters, are here given in full:

On account of the diversified characteristics of the waters investigated, the variety of their products, and the magnitude of the industries to which the latter give rise, we have found it impossible to consider fully all of the questions which the subject presents, and have therefore been unable in many cases to reach more than general conclusions, leaving the matter of details to be settled by further and more complete inquiries. Our observations, moreover, have clearly demonstrated the inexpediency of attempting to regulate any of the fisheries herein discussed by a rigid code of enactments, owing to their constantly changing character and conditions, and we would therefore urge, in the event of joint action by the two Governments, that a permanent joint commission, to be composed of competent experts, be provided for, which shall be charged with the direct supervision of these fisheries, and shall be empowered to conduct the necessary investigations and to institute such modifications in the regulations as the circumstances may call for from time to time.

CVI REPORT OF COMMISSIONER OF FISH AND FISHERIES.

That a uniform system of regulations common to the entire extent of each body of water along the boundary line is required to insure the protection of its resources, is fully shown by the conditions which we have found to exist in nearly all of them, whether bordered on the side of the United States by a single State or by several States. The failure to secure adequate results in that direction has naturally been due to the diversity of legislation, but it has resulted in large part from the general lack of accurate information regarding the habits of the several fishes to serve as a basis for intelligent action. While we have been able to establish some important facts respecting the natural history of the commoner market species, much more remains to be accomplished in that regard, and the subject should be given due prominence in the future.

All questions, outside of navigation, with which we have had to deal have been considered solely from the standpoint of the preservation of the several fisheries, and we have endeavored in each instance to provide for the most liberal amount of fishing which, in our judgment, is warranted by the circumstances. In so doing we have been led to suggest greater license in some regions than is granted by existing laws, but wherever a State on the one side or the Dominion Government on the other would impose greater strictures than are here recommended we see no objection thereto.

We are convinced that no system of regulations can be properly administered except by the registration or licensing of the fishermen, as a basis for restricting the character and amount of apparatus employed in each locality, while, on the other hand, we feel confident that the fishermen themselves would be greatly benefited by such a measure, through the protection of individual rights thereby assured them.

Much of the irritation occasioned from time to time, especially in the region of the Great Lakes, through the fishermen of one country extending their operations into the territory of the other, has undoubtedly resulted from the imperfect knowledge which prevails respecting the relations of the intervening water areas. In fact, the belief is widespread that wherever the lakes exceed 6 miles in width each country has jurisdiction only to a distance of 3 miles from its shores, leaving a neutral area or high sea between, to which the fishermen from both sides are privileged to resort in common.

On the official maps of the Great Lakes the boundary line is not shown, nor can its position be accurately marked in most places until new surveys shall be made conjointly by the two Governments. It would be greatly to the advantage of the fishing interests in that region, and much annoyance would be prevented in the future by having the boundary line redefined and appropriately located on a series of charts made available for distribution among the fishermen.

ST. JOHN RIVER SYSTEM.

In order to restore and protect the fishery resources of international interest in the St. John River system, the following measures seem to be demanded:

(1) That all dams throughout the system be provided with suitable fishways, except those used exclusively for log driving and containing gates, and that the latter shall be kept open at all times when the driving of logs is not actually in progress, and just previous thereto for the collecting of water.

(2) That the construction of all new dams be subject to governmental authority and conform to such requirements in each case as the circumstances may warrant.

(3) That the practice of throwing sawmill waste of any kind into the water be everywhere prohibited; and that all existing accumulations of such waste in streams where it may be detrimental to the movements or spawning requirements of useful fishes be removed. As the sawmills situated in the city of St. John have been able for many years to dispose of their rubbish without recourse to the adjacent river, it is not considered that this provision would work undue hardship in other places.

REPORT OF COMMISSIONER OF FISH AND FISHERIES. CVII

(4) That it be prohibited to throw or to allow to pass into the water any garbage, lime, waste from gas works, or other deleterious substances from manufacturing or other establishments.

(5) That commercial fishing be limited to tidal waters, and be so restricted therein as to insure an ample run of salmon and other anadromous fishes to their respective spawning-grounds.

(6) That uniform regulations be adopted for the protection of the salmon, trout, and other useful fishes throughout the fresh waters of the system.

(7) In case the measures above suggested are carried out, it is recommended that joint action be taken to increase the supply of salmon by artificial propagation.

(8) It is recommended that all natural obstructions which impede the passage of salmon to important waters adapted to their spawning, such as the fall near the mouth of the Aroostook River, be examined with reference to improving the conditions for the distribution of that species.

ST. CROIX RIVER SYSTEM.

(1) That the disposal, through the medium of the water, of all kinds of-sawmill refuse be prohibited throughout the entire river system. Sawdust is the only kind of such refuse now understood to be disposed of in this manner, and its retention on land can undoubtedly be provided for at comparatively slight expense, as has been done in other places.

(2) That all extraneous material encumbering the channel of the river in tidal water between the Calais-St. Stephen Bridge and The Ledge, and resulting from the deposition of sawmill refuse, be removed. This measure is requested in the interest especially of navigation, but there is no doubt that the fisheries would also be benefited thereby. We do not consider, however, that such a step would be justifiable while the practice of allowing said refuse to escape into the river still continues. It would also be of great advantage to the fisheries if the beds of sawmill refuse occurring between Union Dam and Fourth Dam, above tidal waters, could be removed to the extent of providing at least a wider and more direct channel for the passage of salmon.

(3) That the sewage from the St. Croix Cotton Mill be disposed of in such manner as to prevent any harmful influence upon the salmon in that vicinity during their ascent of the river.

(4) That the tanneries be prohibited from using the streams adjacent to them for the disposal of tan bark, tan liquor, fleshings, hair, or other refuse which may be deleterious to fishes. All liquids from the washings of the hides containing any harmful ingredients should be purified before being allowed to enter the stream.

(5) That all fishways and passageways through the several dams be placed in good repair and be modified where necessary to insure their greater efficiency, and that subsequently they be maintained in proper condition and their approaches kept clear of drift materials. The construction of all new dams should be subject to Government authority, and should conform to such requirements in each case as the circumstance may warrant.

(6) That in the case of all log-driving dams provision be made to keep one or more of the gates open at all times when their use is not actually required in connection with the driving of logs.

(7) That in those streams to which the salmon resort for spawning purposes all sources of pollution be restrained and all obstructions and existing impurities be removed as far as possible.

(8) That net fishing be prohibited throughout the fresh waters of the system.

(9) That the capture of salmon in the neighborhood of their spawning-grounds and in the approaches to fishways, or by any means except hook and line, be prohibited.

(10) That appropriate and uniform regulations be established with respect to all classes of fishing in the fresh waters of the system, the same having reference to methods and extent of fishing, close seasons, etc.

CVIII REPORT OF COMMISSIONER OF FISH AND FISHERIES.

(11) That in the event of the removal of all obstructions and polluting agencies and the establishment and enforcement of suitable regulations, the increase of the supply of both salmon and landlocked salmon by artificial means be attempted through the cooperation of the two governments.

PASSAMAQUODDY BAY AND VICINITY.

International fishery interests in Passamaquoddy Bay and its neighborhood are concerned chiefly with the preservation of the herring, and as no decrease of that species has been proved, beyond the disappearance of the winter school, which can not be attributed to overfishing, it is not considered necessary to suggest any changes in the methods employed, and the only recommendations made are as follows:

(1) As the present regulation providing for a close season on the principal spawning-grounds off Grand Manan has undoubtedly been a wise one, and may have, to some extent, aided in maintaining the supply of herring, it is recommended that it be continued and that a similar close season be adopted for a part of the herring spawning-grounds off Machias.

(2) It is recommended that a regulation be adopted prohibiting the use of herring for the manufacture of oil or fertilizer.

(3) It is recommended that the minimum size of lobster which may be taken be fixed at 10½ inches, and that all lobsters caught, by whatsoever means, under that size be returned alive to the water.

(4) It should be made unlawful to take berried lobsters at any time.

(5) With a view of protecting the smelt, a close season, extending from March 15 to July 1, is recommended, during which close season it should be unlawful to take smelt in any manner except with hook and line.

LAKE MEMPHRETAGOG.

The interests of this lake can undoubtedly best be served by fostering the game fishes, and, in our opinion, this should be done to the extent of prohibiting all net fishing. The lake has become an angling resort of much importance, and as long as its attractions in that respect are properly maintained, the local welfare will be benefited more materially through the influx of visitors than by the continuance of a commercial fishery dependent on so small a basis of supply as that furnished by these waters.

The use of spears, which are employed on the spawning-grounds, is also to be regarded as detrimental and should be stopped.

It is further recommended that the black bass and lake trout be protected by close seasons, extending from November 1 to June 15 in the case of the former species, and from September 1 to January 1 in the case of the latter.

LAKE CHAMPLAIN.

(1) That no net fishing other than by seines be permitted in waters adjacent to the boundary line or elsewhere in the lake where international interests would be affected thereby.

(2) That the use of seines be permitted from February 1 to March 31, inclusive, for the capture of wall-eyed pike and other associated species, but under such limitations as to localities and number of nets employed as shall amply provide against the decrease of the species named. Should further inquiry establish the fact that this fishery is proving harmful to the wall-eyed pike by materially reducing the supply, its abolishment is recommended.

(3) That the use of seines be permitted during the month of October for the capture of whitefish and other associated species under suitable restrictions as to localities and number of nets employed.

(4) That the length of any seine shall not exceed 40 rods; and that the mesh of the seines shall not measure less than 2½ inches in the bunt and 3 inches in the wings.

(5) That the capture of black bass be entirely prohibited from November 1 of each year to June 15 following; that angling methods only be allowed for this species and the catch by each angler be limited to 15 fish daily; and that all bass taken in nets, and all bass measuring less than 10 inches long taken by anglers be immediately returned alive to the water.

(6) That the capture of wall-eyed pike by any means be prohibited from April 1 to May 31, inclusive, of each year.

(7) That joint regulations be also adopted with respect to any game or other fishes not specifically mentioned which may require protection.

RIVER ST. LAWRENCE BETWEEN THE STATE OF NEW YORK AND THE PROVINCE OF ONTARIO.

As an arrangement approved of by the sporting community has already been entered into for the greater part of the waters under discussion between Canada and the State of New York and the necessary legislation provided for, we consider it unnecessary to suggest any other regulations than those already agreed to. We are, however, of the opinion that a small amount of commercial fishing, made with fyke nets, fished during the winter months in creeks or marshy places for such species as bullheads, perch, suckers, sunfish, etc., could do no harm. If such nets were allowed they should not be set before November 1, and they should be removed from the water by March 31. Fished during such a season, in suitable localities, there could be no risk of their taking bass, wall-eyed pike, or maskinongé. A set-line fishery might also be allowed for such fish as sturgeon, eels, ling, and channel cat, as the removal of some of these fishes would certainly be of benefit to sporting interests.

Under the arrangement made between Canada and the State of New York it was enacted:

(1) That no commercial fishing be permitted in the waters of the St. Lawrence between a line drawn from Cape Vincent, in the State of New York, to the city of Kingston, in the Province of Ontario, and a second line from the town of Prescott, in Ontario, to the city of Ogdensburg, in New York.

(2) That within the waters above included the close season for bass, maskinongé, wall-eyed pike, and grass pike be from the 1st day of January to the 9th day of June, inclusive, in each year.

(3) That the limit of the number of bass to be taken by each rod per diem be fixed at twelve, and that the number of rods to each boat be limited to two.

(4) That all undersized and immature fish be returned alive to the water, and that no bass under 10 inches in length be taken.

While we do not consider that the close season as enacted above by any means fully covers the spawning season of the bass, which in the region of the Thousand Islands extends from the 15th of May to the 1st of July, at least, yet when taken in conjunction with a size limit, a limit to the number taken by each rod per diem, and a further limit of the number of rods per boat, it may be allowed that the protection is ample for the present.

We would recommend a continuance of the above arrangement and would further suggest that it be extended so as to include the rest of the St. Lawrence from the lower limit above mentioned, between the cities of Ogdensburg and Prescott, to the point where the river ceases to be the boundary between the two countries, at the crossing of the line of 45° north latitude.

LAKE ONTARIO.

In view of the extent to which the supply of both whitefish and lake trout has become exhausted in Lake Ontario, any regulations looking to the protection and increase of those species, in order to be effective, should be decidedly stringent.

CX REPORT OF COMMISSIONER OF FISH AND FISHERIES.

With respect to the fisheries for them and for the other important fishes of the lake we recommend as follows:

(1) That a close season be adopted for both the whitefish and lake trout from the 15th day of October to the 31st day of December, between which dates they shall not be fished for or taken in any manner.

(2) That in the Bay of Quinte the close season for whitefish extend from the 1st day of October to the 31st day of December, and that the use of herring gill nets in that bay be prohibited during November.

(3) That the minimum size of mesh in the gill nets fished for whitefish and trout be fixed at 5 inches, in the herring gill nets at 2½ inches, and in the sturgeon gill nets at 11 inches.

(4) That the quantity of gill nets used in connection with each fishery be restricted within proper limitations.

(5) That the use of baited set lines for sturgeon be permitted, but that the capture of that species by means of naked hooks or grapplings be prohibited.

(6) That all sturgeon measuring less than 4 feet long, taken by any means, be returned alive to the water.

(7) That a close season be adopted for the black bass from May 1 to June 15; that all black bass measuring less than 10 inches long, by whatever means taken, be returned alive to the water; that the number of bass taken by each rod per diem be limited to 20, and that the number of rods to each boat be limited to 2.

(8) That it be permitted to fish fyke nets and trap nets in the inshore waters of the lake for the capture of the coarser fishes between the 1st of October and the 30th of April, within proper limitations as to number and under such restrictions as shall prevent their being set on the spawning-grounds of whitefish, trout, or herring, or in such manner as to interfere with the spawning movements of those species.

(9) That the mesh in the bag of all trap nets and fyke nets measure not less than 2½ inches in extension when in use.

(10) That the use of seines on or about the spawning-grounds of any of the important fishes during their spawning season be prohibited.

(11) That the joint efforts to increase the supply of whitefish and lake trout by artificial means be continued, and that the scope of that work be increased to the fullest extent possible. It is recommended that the planting of the fry be not restricted to one part of the lake, but be extended to as many of the important spawning areas as possible.

(12) That the throwing into the water of fish offal, including dead fish taken from the nets, of city garbage, and of all other substances deleterious to fish life be prohibited. That steps be taken to prevent injury by the waste from sawmills, gas works, oil refineries, etc., especially in tributary streams containing spawning-grounds of important fishes.

LAKE ERIE.

Pound nets.—It is imperative that the extent of the pound-net fishery, especially in the western part of the lake, be very materially reduced, and that the positions and distances apart of these nets be so regulated as to make ample provision for the free circulation of the several important fishes. Although further observations will be necessary before the limitations of so comprehensive a measure can be properly adjusted or its details perfected, we venture to offer the following suggestions respecting it:

That the total number of pound nets in the lake be limited to 1,000. The reduction in the number is intended to apply mainly to the United States waters from Vermilion westward.

That the number of such nets set in a string be restricted to 6 on the United States shore and to 3 on the Canadian shore.

That the length of the pound-net leaders be restricted to 50 rods.

That in all strings the individual pound nets be separated by gaps between each crib and the next succeeding leader, which gaps shall be at least 50 feet wide and shall extend to the bottom.

That all pound nets or pound-net strings be separated laterally by interspaces of at least 1 mile.

That no pound nets or strings of pound nets be allowed to begin in a less depth than 10 feet or to extend out into a greater depth than 40 feet.

That in the vicinity of the islands at the western end of the lake the length of pound-net strings be further regulated in accordance with local conditions, but in no case should these nets obstruct more than one-third the width of any channel or passageway.

That the use of pound nets be prohibited on any reef or ground on which whitefish or herring are known to spawn, or within a reasonable distance therefrom.

That the use of pound nets be prohibited in any locality where young whitefish may be taken in undue quantity.

That the mesh in all pound nets measure in extension at least $2\frac{1}{2}$ inches in the crib, after shrinkage.

That all pound-net stakes be removed from the water within thirty days from the close of the fall fishing season.

Gill nets.—The mesh in the gill nets used for the capture of herring, wall-eyed pike, blue pike, and saugers should measure at least $3\frac{1}{2}$ inches in extension, and the employment of any gill net having a smaller mesh should be prohibited.

A very large reduction is called for in the extent of fishing with the small-meshed gill nets, especially for the herring and wall-eyed pike. In case this can not satisfactorily be accomplished by reducing the amount of netting employed, practically the same result may be reached by instituting a close season, which should preferably occur at the time of year when the greater waste of fish takes place.

We recommend that the use of the small-meshed gill nets be entirely prohibited west of a line connecting Point Pelée with Vermilion Light between July 1 and January 1.

In any locality where the small-meshed gill nets are liable to take an undue quantity of undersized whitefish their use should be prohibited, at least during the period when such undersized fish are there present.

The mesh in the gill nets used for the capture of whitefish should measure at least $4\frac{1}{2}$ inches in extension, and it is considered that a 5-inch mesh would be preferable.

The quantity of whitefish gill netting now employed appears to be excessive, in view of the continued depletion of the whitefish, and it should be restricted unless the protection of the species can be better provided for by a close season.

The mesh in the gill nets used for the capture of sturgeon should measure at least 11 inches in extension.

It seems to us that the gill-net fishery for sturgeon at the eastern end of the lake is being conducted on too large a scale, and that a reduction should be made in the number of nets employed; but a special investigation will be required to determine the proper means of regulating this fishery. The hook-and-line fishery for the sturgeon also needs to be taken into consideration in the same connection.

The use of any gill net within one-fourth of a mile of any fixed net, such as a pound net or trap net, should be prohibited.

Fyke nets and trap nets.—The mesh of these nets should conform to the same regulations provided for the pound nets. Their number should be restricted in accordance with the capacity or requirements of each region in which they are fished. A great reduction in the number of the fyke nets is demanded in several places.

Seines.—The dimensions of seines and the size of mesh therein should conform in each instance to the conditions under which they are employed. The mesh should in all cases be sufficiently large to permit the escape of undersized fish, and the number of seines, as well as the manner of their use, should be properly restricted in all places.

CXII REPORT OF COMMISSIONER OF FISH AND FISHERIES.

It should be prohibited to fish seines on or about the spawning-grounds of the black bass, the pike-perches, or other important fishes during their spawning season or while the eggs and young fish continue to remain upon the grounds, and in all other places where the employment of this method would be unduly harmful.

Naked hooks for sturgeon.—It is recommended that the method of taking sturgeon by means of naked hooks or grapnels be prohibited.

Spears.—The use of spears for taking fish of any kind should be prohibited.

Whitefish.—This species is the one most urgently demanding protection, as well as efforts to rehabilitate the supply. A large reduction in the amount of apparatus used for its capture, accompanied by extensive fish-cultural operations, may be expected to aid materially in replenishing the stock; but we venture to suggest that, in our opinion, even greater benefits might be gained by the discontinuance of all fishing for the species during all or a part of its spawning season, as elsewhere explained.

Sturgeon.—All sturgeon measuring less than 4 feet long, taken by any means, should be returned alive to the water.

Black bass.—All fishing for black bass, including its capture by any means, should be prohibited from at least May 1 to June 15; and all bass which may be taken in the nets during that period should be returned alive to the water. No black bass measuring less than 10 inches, taken by any method, should be retained or sold.

Pollutions.—The throwing into the water of fish offal, including dead fish taken from the nets, of city garbage, and of all other substances deleterious to fish life should be prohibited. Steps should also be taken to prevent injury by the waste from gas works, oil wells, oil refineries, etc., especially in tributary streams containing spawning-grounds of important fishes. It is recommended that in connection with all harbor improvements and other work of that character due precautions be taken in disposing of the materials obtained by dredging, etc., to prevent injury to any fishing-grounds.

Propagation.—A continuance of the joint efforts to increase the supply of whitefish by means of artificial propagation is strongly recommended, and it is urged that the scope of this work be increased to the fullest extent possible.

DETROIT RIVER, LAKE AND RIVER ST. CLAIR.

(1) That the use of all nets, excepting seines employed in obtaining whitefish for the hatcheries and seines with not less than 4-inch mesh for catching sturgeon, be prohibited in the waters of the Detroit and St. Clair rivers.

(2) That all fishing with seines, traps, or other forms of nets be prohibited in Lake St. Clair north of a line drawn from the mouth of the Clinton River in Michigan to the mouth of the Thames River in Ontario.

(3) That the minimum size of mesh in the cribs of pound nets, trap nets, and fyke nets be not less than 2½ inches in extension.

(4) That no nets whatever be permitted to be used between the 31st day of October and the 1st day of December, excepting for the purposes of the hatcheries.

(5) That a close season be adopted for the black bass from May 1 to June 15; that all black bass measuring less than 10 inches long, by whatever means taken, be returned alive to the water; that the number of bass taken by each rod per diem be limited to 20, and that the number of rods to each boat be limited to 2.

(6) That all sturgeon less than 4 feet long be returned alive to the water.

(7) That all fishing with grapnels or naked hooks be prohibited, but that all other hook-and-line fisheries be permitted, except for black bass between May 1 and June 15.

(8) That the throwing into the water of fish offal, including dead fish taken from the nets, of city garbage, and of all other substances deleterious to fish life be prohibited. That steps be taken to prevent injury by the waste from sawmills, gas works, oil refineries, etc.

LAKE HURON.

Pound nets.—A reduction in the number of pound nets in some places, especially in the northern part of the lake, and probably also in Saginaw Bay, is called for.

The recommendations made under pound nets in Lake Erie with respect to the length of leaders, the separation of individual nets in the string by gaps, and their distance apart are considered to be applicable also to Lake Huron. It is recommended that in Saginaw Bay not more than 6 pound nets be allowed in a string, and elsewhere in the lake not more than 3.

North of a line drawn from North Point, Michigan, to Clark Point, Ontario, the mesh in the cribs of all pound nets should measure not less than 4 inches in extension after shrinkage, and south of said line not less than 2½ inches. This would provide for the use of only a large mesh in that part of the lake where the whitefish is the most important species and where the young are being captured in undue quantities, and would permit the taking of herring and other small species in those localities where they are now mainly fished for. In the latter case the proposed mesh is also larger than the one now employed, and would perhaps serve to liberate a certain proportion of the undersized wall-eyed pike, which are at present a conspicuous feature of the catch.

The use of pound nets during November should be prohibited north of the line above defined, in order to provide a close season for whitefish.

All pound-net stakes should be removed from the water within thirty days after the close of the fishing season.

Gill nets.—The mesh in all gill nets should measure at least 5 inches in extension, except that nets of 2½-inch mesh might be allowed to be fished on the Canadian shore between Sable River and Cape Hurd, from October 15 to November 1, for the capture of herring, which, at that season, do not appear to be associated with young whitefish in that locality.

During November it would be expedient to prohibit fishing by any gill net having a smaller mesh than 6 inches, which would serve in large measure to protect the spawning whitefish. The use of any gill net within one-fourth mile of any fixed net should be prohibited. The mesh in gill nets used for the capture of sturgeon should measure at least 11 inches in extension.

Fyke nets.—The mesh in the bag of fyke nets should measure at least 2½ inches in extension. The number of these nets should be restricted in accordance with the capacity or requirements of each region in which they are employed.

Seines.—The dimensions of seines and the size of mesh therein should conform in each instance to the conditions under which they are employed. The mesh should in all cases be sufficiently large to permit the escape of undersized fish, and the number of seines, as well as the manner of their use, should be properly restricted in all places. It should be prohibited to fish seines on or about the spawning-grounds of any of the important fishes, or in any place where their employment would be unduly harmful.

Naked hooks for sturgeon.—The method of taking sturgeon by means of naked hooks or grapnels should be prohibited.

Spears.—The use of spears for taking fish of any kind should be prohibited.

Sturgeon.—All sturgeon measuring less than 4 feet long, by whatever means taken, should be returned alive to the water.

Pollutions.—The throwing into the water of fish offal (including dead fish taken from the nets), of city garbage, and of all other substances deleterious to fish life should be prohibited. Steps should also be taken to prevent injury by the waste from sawmills and from manufacturing establishments of all kinds, both along the shores and in all tributaries containing spawning-grounds of important fishes. It is recommended that in connection with all harbor improvements and other work of that character, due precaution be taken in disposing of the material obtained by dredging, etc., to prevent injury to any fishing-grounds.

CXIV REPORT OF COMMISSIONER OF FISH AND FISHERIES.

Propagation.—A continuance of the joint efforts to increase the supply of whitefish and lake trout through the agency of artificial propagation is recommended.

LAKE SUPERIOR.

The remedial measures suggested for Lake Superior are as follows:

(1) In all localities where there is evidence of overfishing by the pound nets the number of the latter should be suitably restricted. These nets should be separated by an interval of at least 1 mile, and they should not be allowed to extend more than one-third the distance across any channel or passageway.

(2) Where young whitefish abound and may be captured by the pound nets in appreciable quantities, the use of such nets should be prohibited either entirely or during such periods as the young of that species may be so present.

(3) The mesh in the cribs of all pound nets should measure at least 4 inches in extension when in use.

(4) It would seem that the extent of gill-net fishing for whitefish and trout had reached, if not passed, a safe limitation, and that some restriction should be placed upon the quantity of gill nets to be fished hereafter. Further observations, however, are required to establish a satisfactory basis for action in this matter.

(5) The mesh in gill nets employed for the capture of the common whitefish and the lake trout should measure not less than 4½ inches, and we consider that a 5-inch mesh would be preferable.

(6) The herring gill nets and those used for the smaller varieties of whitefish require a smaller mesh than the above, but the conditions under which such nets may be employed should be explicitly defined.

(7) No restrictions appear to be called for at present in respect to the herring gill nets, except that their use should be prohibited wherever young whitefish would be taken in them.

(8) The number of seines employed at present is relatively small, and it should not be allowed to increase beyond a safe limitation.

(9) The mesh in whitefish seines should measure not less than 3½ inches in the bunt and 4½ inches in the wings.

(10) The use of all kinds of seines should be prohibited wherever the capture of young whitefish is involved, either entirely or during the seasons when the young are present.

(11) It is considered that it would be beneficial to institute a close season covering the spawning period of the whitefish, during which no fishing for the species should be permitted.

(12) All sturgeon measuring less than 4 feet long which may be taken by any means should be returned alive to the water.

(13) It may be found advisable to establish local regulations for the protection of the wall-eyed pike in places where they occur, but no information that would be serviceable in that respect has been collected.

(14) The throwing into the water of fish offal and of all other deleterious substances in places where it would be harmful to fish life should be prohibited.

(15) Joint efforts for the increase of the supply of both the whitefish and the lake trout by means of artificial propagation are recommended.

LAKE OF THE WOODS, RAINY LAKE, AND RAINY RIVER.

International interests on Lake of the Woods are concerned chiefly with the preservation of the sturgeon. Although the pound-net catch of scale fish is comparatively large and important, especially at certain seasons, should the capture of sturgeon become unprofitable at any time, that method of fishing would probably be mostly, if not entirely abandoned, and little else be done thereafter in waters closely adjacent to the boundary line. As both the scale fish and sturgeon, however, are taken together and under the same conditions, their preservation should and can be arranged for on a common basis.

The most effectual measure of relief, and one which we strongly urge be carried out, is a restriction on the extent of fishing, which undoubtedly already far exceeds a safe limitation. It is impossible to determine positively the maximum number of pound nets which could be fished without danger of depleting the supply, as the latter is an uncertain and fluctuating quantity, and the matter will therefore have to be settled arbitrarily; but we are convinced that within the small area to which this kind of fishing is confined the total number of pound nets in use should not exceed 150, to be divided between the two countries in proportion to the extent of shore line belonging to each. Even this number we regard as too large to insure the ultimate preservation of the sturgeon, but we have been constrained not to reduce it still further in view of the fact that the industry has already been firmly established on so large a basis.

Besides the limitation upon the number of pound nets to be employed, we would recommend that not over two such nets be allowed in any one string; that the leaders to the same be not over 50 rods long, each; that the inner end of any pound net or pound-net string be set in not less than 10 feet of water, and that the outer end of the same extend not over 1 mile from the shore; and that no pounds be fished within 1 mile of the mouth of any stream which the sturgeon are known to enter. The object of such provisions is to insure as much freedom of movement for the sturgeon as possible, both during and subsequent to the spawning run.

We also consider it advisable that no gill-net or trawl-line fishing be permitted in the pound-net region, or south of a line extending due east from American Point at the mouth of Northwest Angle Inlet to the Peninsula, except the use of gill nets by the Indians for supplying their own needs.

While a close time covering the spawning season of the sturgeon could not fail to be beneficial, in order to be effective it would require to begin at such a date and to be continued for so long a time as practically to interfere with the entire spring and early summer fishery, the most profitable of the year. A close season is, however, suggested for the wall-eyed pike and whitefish, by restricting the pound-net season to the period beginning May 15 and terminating October 31, which is essentially in accordance with the present custom.

Protection should be afforded the young sturgeon by requiring the return to the water alive, of all individuals taken in the nets which measure less than 4 feet long. At present they are retained when as small as about 3½ feet, the ordinary maximum size being 5½ to 6 feet. No caviare is said to be obtained from sturgeon under 4 feet long, and none of those containing caviare landed during our visit were less than 4½ feet.

The capture of small whitefish, wall-eyed pike, lake trout, etc., should be restricted by regulating the size of mesh, which should measure not less than 4½ inches in pound nets and 5 inches in gill nets.

No fish offal, garbage, sawmill waste, or other polluting agencies should be thrown or allowed to pass into the waters of the lake.

Fishing for sturgeon in Rainy River, except for domestic use, should be prohibited. Further inquiries require to be made in Rainy Lake and the more eastern waters of the system before deciding upon the measures necessary to protect their fishery resources.

WATERS CONTIGUOUS TO THE BOUNDARY LINE BETWEEN BRITISH COLUMBIA AND THE STATE OF WASHINGTON.

(1) The following recommendations are intended to apply only to those waters adjacent to the boundary line between British Columbia and the State of Washington which are traversed by the main body of the sockeye salmon, and to which our inquiries were chiefly restricted. This area may be roughly defined as comprising the Strait of Juan de Fuca and those parts of the Gulf of Georgia and Puget Sound (Washington Sound) lying between the parallels of 48° 10' and 49° 20' north latitude, together with their adjacent bays and tributary streams. We consider, however, that it would be advantageous to extend the scope of any joint regulations which

may be agreed upon to all parts of this inclosed sea, and the information necessary to accomplish that purpose satisfactorily could readily be obtained.

(2) In the salt waters comprised within the State of Washington we see no reason for prohibiting at present any of the kinds of apparatus now employed there, namely, trap nets, purse seines, drag seines, reef nets, and gill nets, the bulk of the sockeye catch being made in the form of net first mentioned.

(3) We are in accord with the Canadian regulation which restricts commercial fishing on the Fraser River and off its mouths to the use of drift gill nets, and recommend that the rivers in Washington be subject to the same regulation.

(4) Being uncertain as to the capacity of the contiguous waters in question in respect to fishing operations, we are not prepared to suggest a direct limitation upon the quantity of apparatus to be employed, but consider that the present requirements of the case will be met by the restrictive measures which follow.

(5) The mesh in trap nets to measure in extension not less than 3 inches in the crib and 6 inches in the leader when actually in use.

Trap-net leaders not to exceed 2,000 feet in length.

Not more than two traps to be placed in one continuous line, and when so arranged to be separated by a gap of at least 100 feet between the inner crib and the beginning of the outer leader. All traps or strings of two traps to be separated by lateral passageways of at least 2,500 feet. The inner end of all trap-net leaders to begin in a depth of not less than 1 fathom at low tide, and the space intervening between it and the shore to remain entirely unobstructed.

All trap-net stakes to be removed from the water, in the interest of navigation, within thirty days from the close of the fishing season.

(6) Drift gill nets not to exceed 150 fathoms each in length.

The drift gill nets employed for taking quinnat salmon to have not less than 7 $\frac{1}{2}$ -inch mesh extension measure, and to be used only from April 1 to September 15.

The drift gill nets employed for taking the sockeye and other smaller species of salmon to have not less than 5 $\frac{1}{2}$ -inch mesh extension measure, and to be used only from July 1 to October 1.

All drift nets when in use to be kept at least 250 yards apart, and to obstruct not more than one-third of the width of the river.

(7) We are not prepared to suggest any changes in the dimensions or in the manner of employing drag seines, purse seines, and reef nets, nor do we consider any such changes essential while the extent of fishing by these methods remains as small as at present.

(8) It is recommended that in all rivers commercial fishing with nets be restricted to the tidal part of the river.

(9) We consider it very important that the movement of the salmon toward their spawning-grounds be facilitated by weekly close times of thirty-six hours' duration, which we suggest extend from 6 a. m. on Saturday to 6 p. m. on Sunday of each week during the continuance of the fishing season.

(10) We also recommend an annual close season, extending from October 1 to April 1 of each year, during which all net fishing shall be prohibited.

(11) We recommend that the Indians be allowed to fish at all times by their customary methods, except the use of drift nets and spears on the rivers during the close seasons, during which periods, moreover, they should be permitted to take salmon only for the purpose of supplying themselves with food, and not for sale or barter.

(12) As no evidence of a decrease in the abundance of any of the salmon species has been obtained, we do not feel justified in recommending joint action at present in the matter of their artificial propagation. While we feel confident that the natural supply can best be maintained by early compliance with suitable protective measures, we found it generally admitted that the efforts made by the Canadian Government to increase the stock of sockeye salmon on the Fraser River by fish-cultural methods has been beneficial, the annual run of the fish being made more constant and the off seasons being improved. In view of the growing demand for

the shipment of quinnat salmon in a fresh condition, which may sooner or later come to exceed the supply, we venture to suggest the possibly greater advantages to be gained by the artificial hatching of that species.

(13) We are convinced that the remedial measures which have heretofore been adopted, although not enforced, for disposing of the fish offal from the canneries on the Fraser River are inadequate to accomplish the results intended, and are also to a large extent impracticable. The practice of throwing this waste material into the river is to be deprecated on general principles; but, except in respect to a few localities, no specific evidence has been presented to indicate that it may be detrimental either to the health of the community or to the welfare of the salmon, and there is no proof that the latter have suffered from this cause. It seems to us that as much, if not greater, harm would result from dumping the offal in the open waters off the entrance to the river as from its disposition in the customary manner in the vicinity of the canneries, providing the necessary precautions are taken. So far as we have been able to ascertain, when thrown into the current of the river in a fresh condition it is practically always dissipated, and produces a nuisance only when placed in quiet, shallow water, or in eddies, which tend to retain it along the shores or to carry it into the adjacent sloughs. Factories established for converting it into oil and fertilizer have failed of success, nor is there any apparent prospect of its extensive utilization in the immediate future.

While suggesting renewed inquiries for reaching a more satisfactory solution of this question, we are constrained to recommend that for the present the current practice be allowed to continue, under such restrictions as may be called for to prevent the accumulation of the offal in any situations where its effect can be shown to be prejudicial. The fishery officer of the district should be empowered to designate all places where the throwing in of this waste should not be permitted.

No complaints respecting the offal in the vicinity of the canneries in the State of Washington have been received from any source, nor do any regulations regarding the manner of its disposition in that region seem to be called for at present.

(14) Waste from sawmills and other substances deleterious to the salmon should not be allowed to pass into any streams which they frequent.

FUR-SEAL INVESTIGATIONS.

The Fish Commission steamer *Albatross* was detailed by the President for duty in connection with the investigation of the fur-seal question in Bering Sea. The inquiries, which were, by act of Congress, placed under the direction of the Secretary of the Treasury, were addressed to the condition of the seal herds on the Pribilof, Commander, and Kuril islands, and were conducted by a scientific commission appointed by the President, consisting of Dr. D. S. Jordan, in charge; Mr. Leonhard Stejneger and Mr. F. A. Lucas, of the U. S. National Museum; Lieut. Commander Jeff. F. Moser, U. S. N., commanding steamer *Albatross*; Mr. C. H. Townsend, naturalist of the *Albatross*; Col. Joseph Murray, special agent of the Treasury Department, and Mr. G. A. Clark, secretary. A similar commission was appointed by the British Government, the members being Prof. D'Arcy W. Thompson of University College, Dundee, Scotland; Mr. James M. Macoun, of the Geological Survey of Canada; Mr. G. E. H. Barrett-Hamilton, and Mr. A. Marett, photographer.

As stated in the last report, the *Albatross* left Seattle on June 24, 1896, having on board all the United States representatives and all the British representatives except Mr. Barrett-Hamilton. The party was

landed at the Pribilof Islands on July 8 and spent the ten days following in observations on the condition of the rookeries. On July 18 the *Albatross* proceeded westward with Dr. Stejneger for the purpose of making similar investigations respecting the seal herds on the Commander and Kuril islands; the rookeries of the Commander Islands being inspected from July 30 to August 9, those of the Kuril Islands from August 22 to August 26, and the herd on Robben Island from August 28 to September 2. The *Albatross* then proceeded to Hakodate, Japan, to refit and to enable Dr. Stejneger to make further inquiries regarding the seals of the Asiatic herd. The vessel then sailed for San Francisco, touching at the Hawaiian Islands.

The commissioners remaining on the Pribilof Islands were engaged in studying the conditions of seal life, in mapping and photographing the rookeries, and in making inquiries as to the methods of the sealing fleet in the adjacent waters. The last-named work was assigned to Messrs. Townsend and Lucas, who cruised among the pelagic sealing vessels on the U. S. revenue cutter *Rush*, examining their catch, noting the sexes of the seals killed, and making dissections intended to throw light on the feeding and breeding habits of the seals. Other investigations relating to pelagic sealing were made later in the season by Messrs. Lucas, Macoun, and Barrett-Hamilton. On August 16 Dr. Jordan and Professor Thompson sailed in the British vessel *Satellite* to make a further examination of the rookeries on the Commander Islands, then returned to the Pribilofs September 1, bringing with them Mr. Barrett-Hamilton. Mr. Townsend returned to San Francisco on August 23 for the purpose of collecting statistics relative to pelagic sealing.

Messrs. Jordan, Thompson, and Lucas started home from the Pribilofs on September 8, the other commissioners remaining on the islands until October 22, with the object of ascertaining the effect of pelagic sealing on the young seals born during the summer.

The result of the season's investigations of the fur-seal fisheries have been published in a preliminary report.* A further decrease in the number of breeding seals on the rookeries of the Pribilof and Commander islands was disclosed, additional evidence on the destructiveness of pelagic sealing was procured, and the resulting starvation of young seals was observed at the close of the season by representatives of both governments.

During the time that the *Albatross* remained at the Pribilofs Captain Moser was engaged in making a survey of the different rookeries, with a view to test the correctness of the maps that had been prepared by earlier investigators. During the cruise from the Commander Islands to Japan the *Albatross* took many soundings in the little-known waters about the Kuril Islands and in Okhotsk Sea and secured at some of the more remote localities a number of hitherto unknown fishes.

* Observations on the fur-seals of the Pribilof Islands, Treasury Document 1913.

THE LABORATORY AT WASHINGTON.

A large amount of miscellaneous investigation and experimentation is carried on at the Washington laboratory. In its relation to the fish-cultural branch of the service the work consists in the examination of specimens of diseased fishes or fishes infested with parasites forwarded from the various stations and in microscopic studies of the food of artificially-hatched fishes. Many specimens of fishes from all parts of the country are sent to the Commission for identification by private individuals, associations, and institutions. The duty of studying and labeling natural-history collections and of preparing sets of same for distribution also falls to the laboratory assistants.

Collections of fishes and other animals made by the vessels and field parties of the Commission are sent to the laboratory of this division to be studied, labeled, and distributed. The collections in a given year are usually larger than can be critically studied and reported on in detail during the same time. During the present year reports on the following collections have been either completed or well advanced: (1) A large series of fishes and crustaceans from the basin of the Columbia River and elsewhere on the Pacific Coast; (2) fishes obtained in the Klamath Lakes basin in 1894; (3) fishes of Vermont collected in 1894; (4) large series of salt-water fishes from Indian River, Biscayne Bay, Key West, Tarpon Springs, and other points in Florida; (5) fishes of the Missouri River basin; (6) very extensive assortment of fishes of the Great Lakes obtained in 1893, 1894, and 1895; (7) fishes from the interior of Florida collected in the winter of 1896-97; (8) miscellaneous fishes secured at points in Alabama, Mississippi, Louisiana, and Texas in 1897; (9) fishes from the interior of New York.

In accordance with the custom long prevailing, collections of fishes and other natural-history specimens were sent to the United States National Museum. The material consisted of (1) a collection of marine invertebrates obtained in the course of oyster investigations in Long Island Sound in 1890 and 1892; (2) a quantity of stomach contents and ovaries of fur-seals secured by the *Albatross* in Bering Sea during several recent years; (3) collections of mollusks from the Pacific Ocean taken by the *Albatross* during the years 1887 to 1896; (4) miscellaneous collections of fresh-water and salt-water mollusks obtained by various field parties during the years 1888 to 1896; (5) collections of mollusks obtained by the *Fish Hawk* in Long Island Sound and on the coast of South Carolina; (6) collections of reptiles and batrachians, containing about 500 specimens, obtained in various parts of the United States by field expeditions; (7) types of 41 new species of fishes collected by the *Albatross* in Bering Sea and the North Pacific Ocean in 1889, 1890, and 1891, and by field parties in Upper Klamath Lake, Oregon, in 1894 and 1896.

The collections of cephalopods, that had been accumulating in the Commission for a long time and included several thousand specimens

from the Atlantic and Pacific oceans, were prepared and shipped to Prof. William E. Hoyle, of Owen's College, Manchester, England. Professor Hoyle is a recognized authority on this group of mollusks, and kindly agreed to study and report on the Commission's collections.

Tow-net collections of small crustaceans from lakes in Idaho, Washington, and Oregon, obtained by assistants of the Commission in the course of ichthyological explorations, were, by request, transmitted for study to Prof. S. A. Forbes, director of the State Laboratory of Natural History, Urbana, Ill., who had previously given the Commission several valuable reports on this class of animals.

A lot of sea-weeds collected by the *Albatross* in Alaska was sent to Prof. W. A. Setchell, of the department of botany in the University of California, for examination and report.

A complete working series of American fishes is a great desideratum in the laboratory, and active measures have been taken to fill out the reserve collection and arrange it in a manner convenient for ready reference. While the small size of the laboratory precludes the possibility of having a large series of specimens on hand, there is ample room for typical examples of all the fresh-water species and the smaller salt-water ones.

A special collection of considerable importance has been begun, consisting of carefully identified immature fishes of various sizes and ages, more especially those which are propagated by the Commission or are related to those artificially cultivated.

THE WOODS HOLE LABORATORY.

The laboratory of the Commission at Woods Hole was operated in the usual manner during this year. The privilege of using the tables, equipment, and facilities was extended to a number of persons from various well-known educational institutions, who were given sleeping accommodations in the residence building. The laboratory was ready for occupancy July 1 and remained open till about October 1, Mr. Alexander Jones, the acting superintendent of the station, being in general charge.

The investigators who were granted the privileges of the laboratory, the institutions they represented, and the subjects of their studies were as follows: Mr. Ulric Dahlgren, Princeton University, nervous system of flounder; Mr. Alfred A. Doolittle, Princeton University, embryology of echinoderms and collecting; Mr. Leonard H. Robbins, Princeton University, anatomy of dogfish; Mr. F. C. Waite, Harvard University, development of green glands in decapoda; Mr. George Lefevre, Johns Hopkins University, budding of ascidians; Dr. Reid Hunt, Johns Hopkins University, stimulation of cardiac nerves of fishes; Prof. C. C. Nutting, State University of Iowa, description and classification of hydroids; Dr. William Patten, Dartmouth College, phylogeny of horse-shoe crab; Dr. J. H. Gerould, Dartmouth College, nervous system of

echinoderms; Mr. W. A. Redenbaugh, Dartmouth College, nervous system of horseshoe crab; Mr. H. M. Chase, Dartmouth College, anatomy of elasmobranchs; Mr. Ellis Kerr, Northwestern University, urogenital system of amphibia; Mr. H. B. Cragin, Northwestern University, development of olfactory nerve and histogenesis of nasal epithelium in *Amblystoma*; Mr. W. H. Dudley, anatomy and development of the lateral-line sense organs in killifish; Dr. H. V. Neal.

NOTES ON FISHES, FISH-FOOD, AND FISH DISEASES.

Reappearance of tilefish.—The history of the discovery of the tilefish (*Lopholatilus chamaeleonticeps*) in 1879, followed by its almost complete extermination from natural causes in 1882, forms one of the most interesting chapters in connection with the food-fishes of the Atlantic coast. In 1892 the *Grampus*, as a result of a special search, succeeded in taking 8 specimens between Marthas Vineyard and the capes of Delaware, the first that had been met with since the great mortality which befell the species ten years previously. In 1897 the tilefish was accidentally taken in such numbers as to suggest a considerable body of fish and to warrant the hope that the early expectations of its taking a place among the food products of the country may eventually be realized. The 78-ton schooner *Mabel Kenniston*, of Gloucester, Mass., was overtaken by a gale on Georges Bank on February 8, 1897, and was blown 120 miles to the westward. After the gale was over haddock trawls were set in 65 fathoms of water, and when the lines were hauled 30 tilefish were caught, weighing from 6 to 15 pounds apiece. Dogfish were very abundant and troublesome, otherwise the captain thought he would have taken fully 100 tilefish. They were landed at Gloucester February 16, and were all eaten locally and pronounced "better than salmon." The weather was very thick, and the vessel's position when fishing could not be definitely determined, but it was 104 miles southwest of No Man's Land, in latitude about 39° 40' and longitude about 72° 10'.

The bluefin whitefish in Lake Superior.—Up to a few years ago the bluefin or blackfin whitefish (*Argyrosomus nigripinnis*) was known only from Lake Michigan and some small lakes in Wisconsin and Minnesota. It has recently, however, come into prominence in Lake Superior, where, in some sections, it is now extremely abundant. Vague reports of the occasional capture of a "blackfin" in Lake Superior have reached the Commission from time to time, but it was not until 1897 that specimens of this species came into the possession of the office; these were three in number, and were sent by Mr. S. P. Wires, the superintendent of the Government hatching station at Duluth, Minn.

The coming into prominence of the bluefin in Lake Superior is analogous to that of the longjaw (*Argyrosomus prognathus*) in Lake Ontario. Both were brought to the notice of the fishermen after a very marked decrease in abundance of the common whitefish (*Coregonus clupeiformis*), whose place they seem, to a considerable extent, to have occupied.

The following interesting notes on the bluefin in this lake have been communicated by Mr. W. D. Tomlin, secretary of the Duluth Fisheries Association:

The coming of the bluefin into Lake Superior waters contiguous to the port of Duluth has been apparently recent. Twelve years ago (1885), when the fishermen here first combined to protect themselves, the bluefin or blackfin was very little known. The fishermen covered hundreds of miles with their fishing operations, leaving their homes very early in the spring and staying until the ice formed on the nets. Many of the present fishermen used to go out about 50 miles and get some fine catches of whitefish in their nets; and as soon as the fall fishing had ended the lake herring—always known as a prolific fish and easily found—was an object for consideration for some weeks until the winter set in. Occasionally one or two bluefins would be taken in a lift of nets. They had no sale, were not recognized as a herring, and could not be passed as a whitefish; so the fishermen used to take them from the nets and clean them at once and let the cook supply them as a pan fish. When thus taken fresh from the icy water and cooked as described they were fine eating, but if left over until the next day they were strong and insipid. When the whitefish began to go farther out into the lake the fishermen followed them, and very few bluefins were taken or even thought of.

As recently as 1894 or 1895 some fishermen, who have homes about 20 miles out from Duluth, on the Minnesota shore, began to set nets entirely for lake trout, because it did not pay them to run 150 miles for whitefish. Then in the fishing once in awhile the larger bluefins would be caught in the trout nets, and since that time the increase has been enormous, and during the past few years they have attained remarkable abundance. During last summer they were a positive drug on the market, and it was almost impossible to sell them, except to those ignorant of the true whitefish. As soon as the lake opens they can be caught by the ton. Booth & Co. state they will not agree to take any of them from the fishermen. They had nearly 20 tons of them in the refrigerator during last summer and could not dispose of them.

At the first appearance of the bluefins they frequented the grounds on which herring had always been caught, but later the schools have extended outward until they are caught on grounds formerly the feeding-grounds of the whitefish. The fishermen are now liable to find them anywhere within 30 miles of Duluth, principally along the Wisconsin shore. As a result of their migration from Lake Michigan they seem to have increased in weight. Some will be found at the 2-pound mark; and, as a result of the rich food supplies that can be obtained at this end of Lake Superior, it will be a matter of no surprise if these fish follow the course of the whitefish and the lake trout and take on bulk and weight. It is stated that Wisconsin will not place any restriction on the fishing for these fish, and Minnesota will possibly follow the same course.

It was at one time surmised that the bluefin or blackfin was a species of whitefish that had been introduced with the multitude of fry that had been turned into the lake by the Fish Commission. Considerable inquiry was made by the fishermen concerning the coming of these fish, and the rumor gained currency that bluefin eggs had been sent up with other eggs and had been hatched out and planted; but Mr. F. N. Clark, superintendent of the Michigan stations of the U. S. Fish Commission, assured me that no bluefins had been planted by the Commission in Lake Superior.

Food of artificially hatched fish.—In order to determine the natural food resources for young black bass of the fish ponds on the river front in Washington in which the propagation of bass has been carried on for a number of years, microscopic examinations of the water and of the stomach contents of recently hatched fry were made in May, 1897. The water was found to be extremely rich in entomostraca, rotifers, and other

animals suitable for bass food, and also in small vegetable and animal organisms on which the fish food subsists. The more abundant forms included species of *Cyclops*, *Daphnia*, *Alona*, *Scapholeberis*, *Amœba*, *Hydra*, *Bothrimonus*, several genera of infusoria, nematodes, *Volvox*, *Spirogyra*, *Micrasterias*, *Euglena*, and some other algæ. The stomach contents of the young bass from the same ponds showed that cladocera were being principally consumed. One small-mouth bass 4 days old contained 10 specimens of *Cyclops*, *Daphnia*, and other cladocera; one 2 days old had 8 specimens of the same animals; three large-mouth bass a few days old had been subsisting on *Daphnia*.

The possible use of finely powdered cereals as food for young whitefish has from time to time been suggested. At Put-in Bay, Ohio, station in 1897 Superintendent Stranahan fed wheat shorts to about 2,000,000 whitefish fry contained in tanks. They at first appeared to thrive, but by May 7 had all died, and specimens were forwarded to Washington for examination. In nearly every case the alimentary tract was well filled with granules of wheat starch, and it was apparent that the fry readily took the food. The nutritive value to fish, however, of such a substance is doubtful, and an examination of the condition of the granules in the hind gut, as compared with those in the anterior part of the alimentary canal, showed no evidence that they had undergone digestion to the slightest degree. The assimilative powers of the very short intestinal canal of the whitefish fry are not sufficiently active to utilize raw vegetable material of this nature. It is possible, however, that by cooking the shorts and diluting them with other food they may prove of service in rearing young whitefish.

Study of rainbow trout and steelhead trout in aquaria.—In the month of April, 1897, the aquaria at Washington contained a large number of artificially hatched rainbow trout (*Salmo irideus*) and steelhead trout (*Salmo gairdneri*). The fish were 4 inches in length and 12 months old, the rainbow trout having been hatched from eggs of domesticated fish at the Wytheville (Va.) station, and the steelheads from eggs of wild fish obtained at Fort Gaston (Cal.) station. Comparing the fish as they appeared in the aquaria, the rainbow trout were relatively shorter and deeper, darker in coloration, with more numerous spots, especially on the caudal fin; the under parts were darker, the middle of the side more rosy; the pectoral, ventral, and anal fins were darker, the white edges being made prominent by contrast. The rainbow trout have the spots on the back larger and more numerous. In the steelhead the spots on the top of head are very much smaller and more numerous. Comparative measurements showed no differences except that the rainbow is somewhat deeper than the steelhead (depth $4\frac{1}{2}$ in rainbow, $4\frac{1}{2}$ in steelhead). The scales in the lateral line are rather larger in the rainbow and the origins of the dorsal and anal fins are more anterior.

Fish parasites and diseases.—About May 15, 1897, a very destructive disease appeared among fresh-water fishes in the aquaria at Washington. The onset of the attack was very rapid, and in a short time spread

to a large number of fishes, young quinnat salmon and young Swiss lake trout being the species chiefly affected. The disease in its appearances and symptoms differed from any previously manifesting itself in the local aquaria, and on examination was found to be due to a protozoan parasite (*Ichthyophthirius multifiliis* Fouquet). This is the same animal that produced great mortality among fishes in the Fish Commission aquaria at the World's Columbian Exposition in 1893, and was there studied by Dr. Stiles, of the Department of Agriculture, whose report on the subject is printed in the Bulletin of the Commission for that year. It is noteworthy that at Chicago the disease first appeared in a lot of catfish (*Ameiurus albidus*) from the Potomac River.

The parasite thickly covers the entire surface of the body and also enters the mouth and gill-cavities and the intestines. The skin becomes coated with a thick mucus, the gills are matted together with slime, and the gill-coverings bulge. The infested fish abstain from eating and remain at or near the surface of the water. The respiratory movements are rapid and gasping. Death is gradual and seems due to a combination of starvation and asphyxiation.

From 60 to 70 per cent of the salmon and nearly all of the trout succumbed to the disease, which was arrested in the course of a month by thoroughly cleaning the aquaria and filling them with a strong salt solution. About the first of May some of the young salmon were sent from Washington to the aquaria at the Nashville Exposition. In a few weeks the disease appeared on them, but they were killed before the trouble had spread to other fishes. Brook trout in the same aquarium were not attacked.

In the spring of 1897 a diving beetle (*Laccophilus maculosus*) appeared in numbers in the fish ponds in Washington and proved destructive to young bass. Dr. H. F. Moore made some observations on its habits and ravages, and found it to be a very dangerous enemy of young fish, which it attacks savagely. Beetles in the larval stage were also discovered in the bass ponds. Suggestions were made as to expedients for preventing subsequent inroads on the young bass.

REPORT OF THE DIVISION OF STATISTICS AND METHODS OF THE FISHERIES.

By HUGH M. SMITH.

This division was under the direction of the writer until April 7, 1897, when Mr. Charles H. Townsend, formerly naturalist on the steamer *Albatross*, was appointed in charge.

The principal work of the division comprised a canvass of the shad and alewife fisheries of the entire Atlantic coast, a reconnaissance of the fishing industry of the Pacific States, inquiries relative to the fisheries of the coastal waters of Florida, and a study of the salmon fishery of Penobscot Bay and River. Besides the general investigation of the fisheries of the Pacific States, some special inquiries were made relative to the sardine industry, the abundance of the introduced shad and striped bass, and the transplanted eastern lobster.

SHAD AND ALEWIFE FISHERIES.

The extensive canvass of the important fisheries for shad and alewives, begun in May, 1896, and noticed in the last report of the division, was completed during the present year, and the Commission was put in possession of very complete and instructive matter regarding the condition of the industry in each stream. In view of the magnitude of the fish-cultural operations with the shad, the inquiries had a special value, because of the opportunity afforded for making comparisons with previous years. The canvass was, in some respects, the most thorough examination of the shad fishery ever undertaken. It included statistics of persons employed, apparatus and boats used, and products taken in each stream or water, the extent of the fishing with each kind of appliance, the number, weight, and value of the shad of each sex, and other special data.

The canvass disclosed the fact that in 1896 the number of persons engaged in the shad and alewife fisheries was nearly 27,000, including only those who used apparatus set especially for these fish or in which they constituted an important part of the catch. Fully 3,500 other persons took more or less shad and alewives incidentally in gill nets, pound nets, and seines operated primarily for other fish. Of the 24,800 persons who may be classed as fishermen, as distinguished from those who simply transported the catch or handled it on shore, over 6,100 persons were employed in North Carolina, more than 4,400 in Maryland, nearly 4,000 in Virginia, about 2,900 in New Jersey, 1,650 in South Carolina, 1,200 in New York, and 1,100 in Pennsylvania.

CXXVI REPORT OF COMMISSIONER OF FISH AND FISHERIES.

The following table shows the number of persons employed in each State:

Table showing by States the number of persons employed in the shad and alewife fisheries of the United States in 1896.

States.	Fisher- men.	Trans- porters.	Shores- men.	Total.
Connecticut.....	278			278
Delaware.....	904			904
Florida.....	487	5	31	523
Georgia.....	888			888
Maine.....	435		10	445
Maryland.....	4,418	17	385	4,820
Massachusetts.....	342		46	388
New Hampshire.....	10			10
New Jersey.....	2,037	38	35	3,010
New York.....	1,180		10	1,196
North Carolina.....	6,112	60	990	7,162
Pennsylvania.....	1,115	4	14	1,133
Rhode Island.....	66		18	84
South Carolina.....	1,646			1,646
Virginia.....	3,972	73	42	4,087
Total.....	24,706	197	1,581	26,574

The investment in vessels, boats, apparatus, and shore property used in these fisheries is very large, amounting, in 1896, to about \$2,172,000. This represented 56 vessels used in transporting the catch or in setting the nets, 12,400 boats, over 4,000 pound nets and similar nets, nearly 950 seines (with a combined length of 133 miles), 84,000 gill nets (aggregate length 1,970 miles), 800 fyke nets, and miscellaneous property.

In North Carolina \$623,000 was invested in these fisheries, the leading item of apparatus being 1,705 pound nets. Virginia is credited with \$442,000 devoted to this industry and with over 1,200 pound nets. In both New Jersey and Maryland more than \$300,000 is invested.

The details of the fishery property in each State are shown in the following table:

Table showing by States the vessels, boats, apparatus, and property employed in the shad and alewife fisheries of the United States in 1896.

States.	Vessels transporting.				Boats.		Pound nets, trap nets, and weirs.	
	No.	Tonnage.	Value.	Value of outfit.	No.	Value.	No.	Value.
Connecticut.....					132	\$3,113	3	\$1,400
Delaware.....	2	15.20	\$600	\$30	442	18,805	9	535
Florida.....					251	9,384		
Georgia.....					495	7,023	26	208
Maine.....	*1	51.85	4,000	408	379	8,527	178	25,255
Maryland.....	7	59.57	4,100	200	2,220	108,632	893	66,266
Massachusetts.....					88	2,974	1	150
New Hampshire.....					12	155	12	480
New Jersey.....	5	298.38	23,000	1,585	1,485	127,592		
New York.....					600	28,731	18	3,890
North Carolina.....	14	138.50	12,225	680	2,960	102,373	1,705	138,598
Pennsylvania.....					408	21,340		
Rhode Island.....					36	700	21	1,010
South Carolina.....					799	14,803		
Virginia.....	27	339.85	14,167	638	2,049	70,588	1,208	227,820
Total.....	56	903.41	58,092	3,631	12,422	530,540	4,074	460,502

* This vessel fished for shad, using a purse seine.

REPORT OF COMMISSIONER OF FISH AND FISHERIES. CXXVII

Table showing by States the vessels, boats, apparatus, and property employed in the shad and alewife fisheries of the United States in 1896—Continued.

States.	Seines.			Gill nets.			Fyke nets.	
	No.	Length (feet).	Value.	No.	Length (feet).	Value.	No.	Value.
Connecticut	47	19,131	\$3,718	80	60,704	\$4,285
Delaware	102	32,853	4,501	457	271,237	14,557	60	\$180
Florida	24	21,450	2,175	201	277,200	17,550
Georgia	428	132,845	13,080
Maine	7	2,562	627	228	56,298	2,870
Maryland	95	104,367	28,422	7,453	1,811,119	59,567	345	5,348
Massachusetts	45	17,739	3,075	10	2,250	120
New Hampshire	2	360	50
New Jersey	145	90,012	17,838	3,658	1,845,368	111,433	270	3,214
New York	67	35,450	7,220	1,870	670,949	34,727	54	955
North Carolina	232	232,740	56,971	58,234	3,417,263	80,062
Pennsylvania	96	67,015	12,285	170	217,770	11,968
Rhode Island	16	9,600	840
South Carolina	22	4,905	931	399	283,011	18,836
Virginia	44	75,183	19,230	10,024	1,253,575	40,131	72	1,032
Total	944	704,276	155,883	84,130	10,309,689	400,116	801	10,729

States.	Dip and other minor nets.		Spears.		Wheels.		Value of shore and accessory property.	Total value of investment.
	No.	Value.	No.	Value.	No.	Value.		
Connecticut	\$1,575	\$14,091
Delaware	10	\$40	13,467	52,715
Florida	4,349	33,458
Georgia	113	250	2,817	23,387
Maine	94	222	11,254	51,253
Maryland	128	625	54,140	925,299
Massachusetts	121	193	12,958	19,470
New Hampshire	355	1,040
New Jersey	90,228	374,890
New York	20	\$20	6,325	81,868
North Carolina	1,278	3,781	75	\$1,125	227,232	622,997
Pennsylvania	51	185	30	23	36,451	82,232
Rhode Island	1,170	4,620
South Carolina	450	1,162	80	2,178	2,645	40,355
Virginia	62,253	441,859
Total	2,245	6,407	50	43	155	3,303	527,248	2,171,554

* Includes fall traps.

The shad catch of the Atlantic coast in 1896 in apparatus set primarily for this fish was 12,940,000 fish, weighing 50,000,000 pounds and valued at \$1,637,000. The yield of alewives was 140,850,000 fish, weighing 58,703,000 pounds and worth \$435,000. The additional output of these fish in apparatus set primarily for other fish was 207,000 shad, with a weight of 775,000 pounds and a value of \$19,000, and 7,008,000 alewives, weighing 3,363,000 pounds and worth \$24,600; included in these figures is the incidental catch of shad on the Pacific coast.

The table which follows gives the results of these fisheries in each State. New Jersey is seen to take precedence in the number and the weight of shad, being credited with about 3,298,000 fish, weighing 13,746,000 pounds. Virginia ranks second, with 3,197,000 fish, with a weight of 11,146,000 pounds. In North Carolina, with a catch of 2,097,000 shad, weighing 8,843,000 pounds, the value is greater than in any other State, namely, \$417,000. Maryland is the foremost State in the yield of alewives; over 44,000,000 were taken, weighing 17,641,000 pounds and valued at nearly \$126,000. In North Carolina about 35,890,000 alewives were caught and in Virginia more than 30,000,000.

CXXVIII REPORT OF COMMISSIONER OF FISH AND FISHERIES.

Table showing the shad and alewife catch of the United States in 1896 by apparatus fished primarily for these fish.

States.	Shad.			Alewives.		
	Number.	Pounds.	Value.	Number.	Pounds.	Value.
Connecticut	67,746	251,810	\$13,486	2,257,798	812,119	\$10,498
Delaware	467,744	1,900,694	60,160	2,057,390	822,956	7,756
Florida	400,214	1,208,605	02,589	40,000	16,000	400
Georgia	143,974	536,627	49,289			
Maine	348,757	1,334,443	29,553	4,670,581	2,598,527	19,664
Maryland	1,542,869	5,540,224	166,464	44,103,306	17,641,322	125,870
Massachusetts	3,355	13,420	934	7,370,689	3,970,274	35,050
New Hampshire				479,500	269,734	2,795
New Jersey	3,297,593	13,746,298	333,188	5,610,990	2,859,200	14,157
New York	537,543	2,181,724	73,596	2,317,070	926,828	11,225
North Carolina	2,096,604	8,842,708	417,243	35,880,798	14,355,920	115,945
Pennsylvania	621,239	2,501,143	79,445	1,572,000	638,500	4,372
Rhode Island	9,258	36,534	2,408	4,364,120	1,745,648	24,333
South Carolina	146,627	671,513	33,430	30,300	12,200	463
Virginia	3,196,672	11,145,870	306,339	30,085,617	12,034,247	62,453
Total	12,940,395	50,091,613	1,637,130	140,849,350	58,703,574	434,981

The incidental catch of shad and alewives is shown by States in the following table. This represents the yield of nearly 800 pound nets, several thousand gill and trammel nets, and about 60 seines, whose individual take was too small to warrant their inclusion in the special statistics.

State.	Shad.			Alewives.		
	Number.	Pounds.	Value.	Number.	Pounds.	Value.
California	61,861	247,445	\$4,397			
Connecticut	2,542	9,380	596	472,625	189,069	\$1,533
Maine	18,169	70,486	1,235	1,567,258	789,790	5,072
Maryland	347	1,275	40	64,980	25,993	180
Massachusetts	30,460	100,712	2,300	2,675,237	1,386,215	10,074
New Hampshire	100	300	15	47,000	23,937	250
New Jersey	40,887	163,528	6,868	733,050	368,775	1,408
New York	5,271	18,822	1,237	211,470	84,588	1,378
Oregon and Washington	31,311	125,246	1,252			
Rhode Island	3,374	12,912	925	828,280	331,312	3,551
Virginia	6,831	24,649	716	408,400	163,360	571
Total	207,153	774,755	19,581	7,008,300	3,363,048	24,617

The extent of the shad and alewife fishing in 1896 is shown by rivers, bays, etc., in the appended tabulation. The large number of streams into which these fishes regularly run make them the leading river fishes of the Atlantic States, considered collectively, and also the principal river fishes in each State with only two or three exceptions.

The Delaware is shown by the table to have been the most important shad stream in 1896. Over 2,800,000 fish were taken, having a value to the fishermen of \$306,000. More than 1,000,000 additional shad were caught in Delaware Bay, this hydrographic area being credited with a catch of over 4,217,000 shad, valued at \$425,000. The second shad stream in 1896 was the Potomac, in which 684,000 fish were obtained. Next in order are the Hudson, with 589,000; the York, with 547,000; the James, with 496,000, and the Rappahannock, with 418,000. In Chesapeake Bay and its numerous tributaries, which constitute the most important shad-fishing ground in the United States, about 4,870,000 shad were taken; these were valued at \$491,000. The extensive fisheries in the basin of Albemarle Sound yielded 1,130,000 fish, worth \$203,000.

REPORT OF COMMISSIONER OF FISH AND FISHERIES. CXXIX

More than half the alewives taken in the United States in 1896 were caught in the Chesapeake basin, in which the run of these fish was phenomenally large. More than a third of the yield of Chesapeake Bay and its tributaries was taken in the Potomac River, which is now the principal alewife stream. In 1896 the fish were so abundant that at times there was no sale for them, and the average price for the season was less than \$1.20 per 1,000. The catch of 24,438,000 alewives credited to the Potomac was nearly equaled on the shores of Chesapeake Bay, where 24,112,000 were taken. The Albemarle region of North Carolina is the next important ground for alewives; 30,675,000 were secured there, of which 13,560,000 were obtained in the Chowan River. Other prominent alewife streams are the Damariscotta (2,472,000 fish), Connecticut (2,216,000 fish), Hudson (2,192,000 fish), Delaware (4,420,000 fish), Susquehanna (10,864,000 fish), and Roanoke (4,177,000 fish).

Statement by waters of the shad and alewife catch of the United States in 1896.

Waters.	State.	Shad.			Alewives.		
		Number.	Pounds.	Value.	Number.	Pounds.	Value.
St. Croix River	Maine				11,100	6,243	\$93
Dennys River	do				160,500	90,280	470
Maobias River	do				91,700	51,581	570
Penobscot River	do	114	421	\$27	617,608	308,844	3,028
Medomak River	do				73,800	41,512	417
St. George River	do				686,000	385,804	3,014
Pemaquid River	do				206,000	115,875	1,100
Damariscotta River	do				2,472,100	1,390,612	9,811
Kennebec River	do	290,122	1,160,488	26,257	494,781	277,726	2,739
Casco Bay	do	64,690	220,020	3,592	1,391,250	701,287	3,771
Shores of Maine	do	12,000	24,000	912	33,000	18,562	323
Piscataqua River	New Hampshire	100	300	15	47,000	23,937	250
Newmarket River	do				46,350	26,088	270
Exeter River	do				433,150	243,646	2,525
Merrimack River	Massachusetts				945,000	472,500	4,200
Cape Cod Bay	do	32,005	86,732	1,449	1,732,972	884,255	5,479
Taunton River	do	3,355	13,420	934	1,897,478	1,067,324	9,478
Ponds, small rivers, and creeks	do				4,528,211	2,480,450	21,372
Shores of Massachusetts	do						
Warren River	Rhode Island	3,555	13,980	851	942,265	501,960	4,595
Ponds and small rivers	do	9,258	36,534	2,408	4,023,200	161,280	692
Shores of Rhode Island	do				3,000,920	1,584,308	23,641
Connecticut River	Connecticut	3,374	12,912	925	828,280	331,312	3,551
Housatonic River	do	51,690	190,034	9,508	2,216,243	795,497	10,350
Shores of Connecticut	do	9,878	37,360	2,471	4,200	1,680	28
Shores of Long Island	do	8,720	32,800	2,103	509,980	204,011	1,653
Hudson River	New York	8,786	31,680	2,241	336,540	134,616	2,840
New York, Sandy Hook, and Raritan bays	N. Y. and N. J.	588,898	2,356,966	83,237	2,192,000	876,800	9,763
Shores of New Jersey	do	216,425	861,653	30,941	930,800	465,400	1,374
Delaware River	New Jersey	16,240	64,037	3,518	3,482,140	1,055,234	8,873
Delaware Bay	N. J., Pa., and Del.	2,833,101	11,752,369	306,536	4,420,700	1,812,980	11,044
Indian River	N. J. and Del.	1,183,761	5,075,801	119,870	221,490	88,596	1,589
Chesapeake Bay and tributaries:	Delaware				550,700	220,280	3,823
Bay shores:							
Susquehanna River	Md. and Va.	1,742,455	6,261,967	177,742	24,112,084	9,644,835	61,709
Northeast River	Md. and Pa.	140,087	505,037	20,153	10,864,000	4,345,600	48,983
Elk River	Maryland	47,205	176,215	5,138	587,400	234,960	929
Chester River	do	14,164	52,250	1,579	2,327,000	930,800	3,884
Choptank River	do	48,703	195,387	7,448	1,219,100	487,604	4,625
Nanticoke River	do	338,420	1,115,020	35,810	1,993,660	797,424	5,598
Patuxent River	do						
Potomac River	do						
Rappahannock River	Md. and Del.	216,324	723,026	20,669	1,527,000	610,800	4,339
York River and tributaries	Md. and Va.	68,015	227,563	8,480	173,300	69,320	628
James River and tributaries	Md. and Va.	29,752	95,482	4,304	32,730	13,092	223
Sassafraz, Transquaking, and Blackwater rivers.	do	52,354	199,200	5,867	1,474,330	589,732	4,008
	do	684,063	2,476,730	63,008	24,437,885	9,775,154	39,003
	do	417,789	1,442,505	35,371	2,798,828	1,119,530	6,411
	do	546,648	1,888,354	50,361	632,798	253,119	3,111
	do	495,762	1,657,203	51,247	528,230	211,292	2,539
	do	28,144	94,202	2,938	2,321,600	928,640	4,124
Total		4,869,785	17,170,741	400,710	75,029,903	30,011,962	190,064

CXXX REPORT OF COMMISSIONER OF FISH AND FISHERIES.

Statement by waters of the shad and alewife catch of the United States in 1896—Cont'd.

Waters.	State.	Shad.			Alewives.		
		Number.	Pounds.	Value.	Number.	Pounds.	Value.
Albemarle Sound and tributaries:							
Sound shores.....	North Carolina	735,192	3,050,809	\$140,159	11,447,204	4,578,882	\$34,671
Pasquotank River.....	do	8,757	30,015	1,599	829,000	331,600	4,167
Perquimans River.....	do	32,822	135,684	6,290	662,500	265,000	2,126
Chowan River.....	do	183,545	762,875	34,422	13,559,600	5,423,840	36,715
Roanoke River.....	do	169,409	678,553	20,489	4,177,000	1,070,800	10,982
Total.....		1,129,725	4,663,930	202,968	30,675,304	12,270,122	97,641
Croatan Sound.....	North Carolina	162,400	680,609	31,731	1,471,500	588,600	6,565
Roanoke Sound.....	do	7,081	30,878	1,470	19,400	7,760	81
Pamlico Sound.....	do	448,089	1,933,142	109,727	1,137,334	454,934	4,112
Pamlico River and tributaries.	do	67,082	289,421	13,316	501,204	200,482	2,374
Neuse River and tributaries.	do	207,052	905,217	39,067	2,085,056	834,022	5,172
Cape Fear River and tributaries.	do	75,315	339,505	18,964			
Winyah Bay and Waccamaw River.	South Carolina.	80,060	371,167	18,454			
Pee Dee River and tributaries.	do	11,071	49,303	2,065	10,100	4,040	167
Black River.....	do	5,825	24,432	1,439	17,600	7,040	264
Santee River.....	do	7,309	32,380	1,547			
Edisto River.....	do	28,273	130,933	5,843	1,800	720	22
Ashpeo River.....	do	6,880	30,335	1,381			
Combahle River.....	do	3,080	13,762	622			
Cooper River and Sampit Creek.	do	1,116	6,095	299	1,000	400	10
Savannah River.....	South Carolina and Georgia.	54,406	214,000	10,230			
Ogeechee River.....	Georgia.	55,425	210,725	10,514			
Altamaha River and tributaries.	do	29,377	95,624	10,090			
Satilla River.....	do	1,500	5,050	240			
St. Marys River.....	Georgia and Florida.	10,193	37,217	1,754			
St. Johns River.....	Florida	456,281	1,284,558	61,924	40,000	16,000	400
Columbia River*.....	Oregon and Washington.	31,311	125,240	1,252			
Sacramento River*.....	California	1,617	6,468	212			
San Pablo and San Francisco bays.*	do	51,894	207,577	3,492			
Monterey Bay*.....	do	8,350	33,400	693			
Total.....		13,147,548	50,866,368	1,656,711	147,857,658	62,066,622	459,598

* Figures are for 1895.

SALMON FISHERY OF PENOBSCOT BAY AND RIVER.

During August and September, 1896, the writer made a personal examination of the condition of the salmon fishery in Penobscot Bay and River. The Penobscot is now the only stream on the Atlantic coast of the United States having an important run of salmon, and it has been the scene of extensive artificial propagation of that species. Most of the salmon fishermen were interviewed for the purpose of securing an account of their fishing in 1895 and 1896 and an expression of their opinion as to the condition of the fishery and the results of fish-cultural work.

The outcome of the fishery was 4,395 salmon in 1895 and 6,403 salmon in 1896, valued at \$11,356 and \$12,716, respectively. As has been the case for many years, practically the entire catch is taken with weirs of various types. Of the 193 weirs set in 1895 and 184 in the next year,

162 were operated in both years. Of these, 90 per cent took more salmon in 1896. The persons engaged numbered 133 each year, and the value of the investment in boats, apparatus, etc., was upward of \$16,000 each season.

Notwithstanding the greatly increased catch in 1896, that season was behind a number of earlier years for which statistics are available. Thus, in 1880 about 10,000 salmon were taken in this region, and in 1887, 1888, and 1889 the catch was still larger. From 1892 to 1895 the output declined about 30 per cent, and the general tendency of late has been toward a decrease, 1896 affording a pleasing contrast.

The salmon fishermen are almost unanimous in the belief that the maintenance of the supply is dependent on artificial propagation. They think the opportunities for natural reproduction are so limited that only a few years would elapse before the supply would become exhausted without the planting of artificially hatched fry. All the eggs collected by the Commission are from fish caught for market, which eggs would otherwise be lost. There was in May and June, 1896, a noteworthy run of small salmon that had then entered the stream for the first time; a corresponding scarcity of large fish was observed. The fishermen refer to these small salmon as the hatchery school.

The interesting experiment is being tried of introducing the quinnat salmon and steelhead trout of the Pacific coast into the Penobscot and other Maine waters. Should it prove successful, two very valuable fishes will be added to the fishing resources of the region.

COASTAL FISHERIES OF FLORIDA.

In October and November, 1896, an investigation of the coastal fisheries of Florida was conducted by the writer and Mr. John N. Cobb, field agent, in conjunction with other Fish Commission representatives who were studying the natural-history features of the Florida fisheries. All the fishing communities on the west coast of the State were visited, and a number of places on the east coast. Most of the latter section, however, had recently been canvassed by agents of the division. The information thus obtained was incorporated in a report submitted to the Senate by the Commissioner on January 28, 1897.

Fishing is one of the principal industries of Florida, and the business is doubtless destined to undergo much further increase in certain lines. The approximate extent of the coastal fisheries at the present time is as follows: Persons employed, 6,100; capital invested, \$1,300,000; value of catch, \$1,200,000.

In this investigation special attention was given to the sponge, oyster, green turtle, and red snapper fisheries, as well as the Key West line fishing and the very extensive mullet fishing on the west coast. Florida is the only State having a sponge fishery, and surpasses all others in the yield of mullet, red snappers, green turtles, kingfish, pompano, and many other products.

The leading fishery is for sponges. It is prosecuted from Key West, Tarpon Springs, Cedar Keys, and Apalachicola, being most extensive at the first-named place. In 1895 the catch amounted to 306,120 pounds, valued at \$386,871, of which 231,272 pounds, valued at \$363,107, were sheepswool sponges.

The next fishery in importance is for mullets, which are caught in enormous quantities along the entire coast of the State, but are most numerous in Indian River and the southern part of the west coast. The yield of fresh and salted mullet and mullet roe in 1895 was about 20,734,000 pounds, having a value of \$311,000.

The red-snapper fishery, centered chiefly at Pensacola, produced 4,899,000 pounds of snappers and a large quantity of groupers incidentally taken. The value of the snappers was \$155,000. The yield and value of other important products in 1895 were as follows: Green turtles, 520,000 pounds, \$28,500; oysters, 270,000 bushels, \$61,723; squeteague, 1,380,000 pounds, \$30,700; redfish or channel bass, 722,000 pounds, \$13,900; grunts, 678,000 pounds, \$16,850; pompano, 615,000 pounds, \$41,000; sheephead, 1,180,000 pounds, \$19,300; Spanish mackerel, 520,000 pounds, \$24,000.

FISHERIES OF GLOUCESTER AND BOSTON.

The reports of the local agents of the Commission at Gloucester and Boston, Mass., show that during the calendar year 1896 the fisheries centering at those places were somewhat less extensive than in the previous year. The quantities of fish which were brought in by the American fishing vessels aggregated 130,673,766 pounds, having a value as landed from the vessels of \$3,286,898. The number of separate fares was 6,407.

Comparing these figures with those for 1895, it appears that there was a decrease of 19,765,774 pounds and \$264,794, with 1,084 fewer fares. The falling off in receipts was shared by both ports.

The vessel fisheries centering at Gloucester yielded 21,924,701 pounds of fresh fish and 45,672,713 pounds of salt fish, a total of 67,597,414 pounds, having a value of \$2,001,904. The aggregate receipts were 9,034,063 pounds less than in 1895, the decrease in value being \$203,715. The number of fares of fish brought into Gloucester was 2,220, of which 1,616 were from grounds off the New England coast, and 604 from the eastern banks, Gulf of St. Lawrence, Greenland, and Iceland. The former grounds yielded 33,604,727 pounds of fish, having a value of \$892,990, and the latter 33,992,687 pounds, worth \$1,108,914.

In the preceding year there were just 1,000 more fares, mostly from the banks lying off the coast of New England, which grounds yielded 38,531,754 pounds of fish, valued at \$894,068, while from the eastern grounds 38,099,723 pounds of fish were brought, having a market value of \$1,311,551.

In the following table the receipts of the different fishes from each ground are given.

REPORT OF COMMISSIONER OF FISH AND FISHERIES. CXXXIII

Summary by fishing-grounds of certain fishery products landed at Gloucester, Mass., in 1896 by American fishing vessels.

Fishing-grounds.	No of trips from each ground.	Cod.				Cusk.			
		Fresh.		Salted.		Fresh.		Salted.	
		Pounds.	Value.	Pounds.	Value.	Pounds.	Value.	Pounds.	Value.
East of 66° W. longitude:									
La Have Bank	89	313,640	\$4,594	1,647,772	\$44,694	47,660	\$617		
Western Bank	48			302,830	8,503				
Quereau Bank	75			77,840	2,188				
Green Bank	23			18,500	548				
Grand Bank	119			17,603,616	320,674				
St. Peters Bank	3			3,000	98				
Burgeo Bank	16			30,100	821				
Bacallou Bank	52	8,000	60	22,600	602				
Off Newfoundland	1								
Cape North	3			702,440	10,218				
Cape Shore	86	393,000	5,849	146,820	3,922	35,000	484	10,640	\$197
Gulf of St. Lawrence.	55			20,100	579				
Greenland and Iceland.	4								
Total	604	709,640	10,503	20,575,418	392,747	82,600	1,101	10,640	197
West of 66° W. longitude:									
Browns Bank	51	974,535	15,573	657,844	16,802	213,580	2,557		
Georges Bank	700	825,340	14,828	11,070,631	324,709	178,200	2,395	294,480	6,379
Cashes Bank	94	934,930	13,766			875,000	10,549		
Pippenies Bank	1					3,000	38		
Middle Bank	9	3,500	92						
Jeffreys Ledge	25	34,500	584	7,600	222	51,400	605		
Ipswich Bay	14	116,736	2,165	8,000	260				
South Channel	82	1,167,555	17,084	15,000	168	449,170	5,094		
Nantucket Shoals	62	40,000	540	1,705,495	34,975				
Off Chatham.	3								
General shore grounds.	585	889,775	7,845						
Total	1,616	4,486,871	72,467	13,404,570	377,136	1,770,350	21,238	294,430	6,379
Grand total	2,220	5,196,511	82,970	34,039,988	769,883	1,853,010	22,339	305,070	6,576

Fishing-grounds.	Haddock.		Hake.				Pollock.			
	Fresh.		Fresh.		Salted.		Fresh.		Salted.	
	Pounds.	Value.	Pounds.	Value.	Pounds.	Value.	Pounds.	Value.	Pounds.	Value.
East of 66° W. longitude:										
La Have Bank	10,000	\$42	190,480	\$940						
Cape Shore			30,000	130	10,000	\$85				
Total	10,000	42	220,480	1,070	10,000	85				
West of 66° W. longitude:										
Browns Bank	11,000	69	200,000	1,005			4,000	\$18		
Georges Bank	1,050,200	4,877	158,000	821	3,500	26				
Cashes Bank	92,000	403	2,034,100	10,338						
Pippenies Bank			3,000	21						
Middle Bank	7,300	222	20,800	100						
Jeffreys Ledge	11,400	436	245,500	1,377	2,500	25	50,860	182		
Ipswich Bay					2,000	20	18,000	81		
South Channel	40,000	154	1,102,240	4,924						
Nantucket Shoals									25,000	\$133
Off Chatham.									230,000	4,353
General shore grounds.	36,186	735	7,000	35			682,322	2,969		
Total	1,248,086	6,896	3,770,640	18,621	8,000	71	755,182	3,250	255,000	4,486
Grand total	1,258,086	6,938	3,991,120	19,691	18,000	168	755,182	3,250	255,000	4,486

CXXXIV REPORT OF COMMISSIONER OF FISH AND FISHERIES.

Summary by fishing-grounds of certain fishery products landed at Gloucester, Mass., in 1896 by American fishing vessels—Continued.

Fishing-grounds.	Halibut.				Mackerel.			
	Fresh.		Salted.		Fresh.		Salted.	
	Pounds.	Value.	Pounds.	Value.	Pounds.	Value.	Pounds.	Value.
East of 66° W. longitude:								
La Have Bank	812,405	\$23,952						
Western Bank	728,375	76,628		3,800	\$212			
Quereau Bank	984,747	77,391		20,080	831			
Green Bank	417,895	29,029						
Grand Bank	2,054,593	102,890	341,325	13,538				
St. Peters Bank	78,040	6,536						
Burgeo Bank	312,588	18,183		7,530	452			
Bacalieu Bank	2,493,209	102,967	494,400	20,425				
Cape North			5,430	326				
Cape Shore	96,007	7,635			4,375	\$520	2,852,000	\$158,550
Gulf of St. Lawrence	9,960	521					623,000	46,823
Greenland and Iceland			334,000	13,530				
Total	7,487,909	445,712	1,206,565	49,314	4,375	520	3,475,000	205,373
West of 66° W. longitude:								
Browns Bank	26,530	1,671						
Georges Bank	1,208,998	99,737			8,720	848	1,446,400	96,125
Cashes Bank	8,000	585					16,000	1,120
Middle Bank					875	92		
Jeffreys Ledge	4,080	234						
Ipswich Bay					1,425	228	1,600	96
General shore grounds					58,680	3,532	4,288,700	173,345
Total	1,248,208	102,227			69,700	4,700	5,752,700	270,686
Grand total	8,736,117	547,939	1,206,565	49,314	74,075	5,220	9,227,700	476,059

Fishing-grounds.	Other fish.				Total.			
	Fresh.		Salted.		Fresh.		Salted.	
	Pounds.	Value.	Pounds.	Value.	Pounds.	Value.	Pounds.	Value.
East of 66° W. longitude:								
La Have Bank					874,275	\$30,145	1,647,772	\$44,694
Western Bank					728,375	76,628	366,630	8,715
Quereau Bank					984,747	77,391	97,920	3,019
Green Bank					417,895	29,029	18,500	584
Grand Bank					2,054,593	102,890	17,944,941	334,112
St. Peters Bank					78,040	6,536	3,000	98
Burgeo Bank					312,588	18,183	37,630	1,273
Bacalieu Bank					2,498,209	103,027	517,000	21,027
Off Newfoundland			200,000	\$2,250			200,000	2,250
Cape North							707,870	10,544
Cape Shore					558,382	14,618	3,019,280	162,754
Gulf of St. Lawrence					9,960	521	643,100	47,402
Greenland and Iceland							334,000	13,530
Total			200,000	2,250	8,515,064	458,948	25,477,623	649,966
West of 66° W. longitude:								
Browns Bank					1,429,645	20,893	657,844	16,802
Georges Bank					3,429,458	123,500	12,814,961	427,239
Cashes Bank					3,944,930	35,641		
Fippenies Bank					6,000	59		
Middle Bank					32,475	506	16,000	1,120
Jeffreys Ledge					398,340	3,418	10,100	247
Ipswich Bay					136,161	2,464	11,600	376
South Channel					2,758,965	27,256	15,000	188
Nantucket Shoals					40,000	540	1,730,495	35,108
Off Chatham							230,000	4,353
General shore grounds	60,600	\$247	420,300	4,586	1,234,563	15,363	4,709,000	177,931
Total	60,600	247	420,300	4,586	13,409,637	229,046	20,195,000	663,344
Grand total	60,600	247	620,300	6,836	21,924,701	688,594	45,672,713	1,313,310

REPORT OF COMMISSIONER OF FISH AND FISHERIES. CXXXV

The quantity of fishery products landed at Boston by American fishing vessels in 1896 was 63,076,352 pounds, valued at \$1,284,994. Compared with 1895, there was a decrease in the receipts amounting to 10,731,711 pounds, worth \$61,079. This decrease was participated in by every important fish except cod and mackerel. The number of fares of fish landed was 4,187, which was 84 less than in the previous year. The following table shows, by fishing-grounds, the quantities of each species landed:

Summary by fishing-grounds of certain fishery products landed at Boston, Mass., in 1896 by American fishing vessels.

Fishing-grounds.	Number of trips from each ground.	Cod.		Cusk.		Haddock.	
		Pounds.	Value.	Pounds.	Value.	Pounds.	Value.
East of 66° W. longitude:							
La Have Bank	112	1,051,000	\$18,849	243,100	\$3,172	1,267,700	\$24,543
Western Bank	37	330,000	6,915	31,300	474	139,000	3,830
Cape Shore	75	604,500	13,203	72,500	875	853,500	10,570
Gulf of St. Lawrence	1						
West of 66° W. longitude:							
Browns Bank	51	495,000	9,605	187,300	2,342	640,000	9,507
Georges Bank	578	4,282,400	84,052	209,000	3,074	10,537,700	153,016
Cashes Bank	70	382,700	7,181	215,700	3,239	383,200	6,736
Clark Bank	6	68,000	1,043			47,000	818
Fippenica Bank	12	34,700	800	24,000	372	50,800	1,225
Ipswich Bay	4	33,000	700			8,000	90
Jeffreys Ledge	298	516,350	12,489	48,500	684	1,458,800	21,712
Middle Bank	377	652,500	13,760	30,000	537	1,648,000	37,104
Race Point	6	5,700	253			16,500	445
Off Highland Light	190	547,600	12,543	5,500	69	1,172,900	22,228
Off Chatham	115	375,300	7,720	8,000	101	1,016,400	17,033
South Channel	556	4,341,400	82,403	250,500	3,083	6,153,600	127,808
Nantucket Shoals	247	3,550,800	67,213			387,600	7,940
General shore grounds	1,452	2,940,210	68,265	83,700	1,012	3,133,500	60,981
Total	4,187	20,251,160	407,693	1,469,100	19,634	28,009,200	521,676

Fishing-grounds.	Hake.		Pollock.		Halibut.	
	Pounds.	Value.	Pounds.	Value.	Pounds.	Value.
East of 66° W. longitude:						
La Have Bank	319,000	\$2,022	53,700	\$344	160,450	\$16,547
Western Bank	100,000	680	14,500	158	133,270	11,687
Cape Shore	141,000	1,278	28,000	307	44,700	3,880
West of 66° W. longitude:						
Browns Bank	92,200	672	15,000	135	118,950	6,376
Georges Bank	547,000	5,098	45,100	389	363,825	30,153
Cashes Bank	345,000	3,611	65,300	231	4,500	623
Clark Bank	5,000	50			22,400	1,644
Fippenica Bank	41,000	563	14,000	70	2,600	321
Ipswich Bay	3,000	30	1,000	5		
Jeffreys Ledge	402,900	4,218	126,100	951	7,200	576
Middle Bank	566,700	6,175	122,200	930	2,500	294
Race Point	1,000	15				
Off Highland Light	240,600	1,653	25,700	220	200	22
Off Chatham	90,200	639	19,400	228	2,200	207
South Channel	2,848,600	19,106	202,700	1,265	60,950	8,408
Nantucket Shoals	13,000	65	135,500	1,077	1,500	90
General shore grounds	778,200	5,476	294,300	1,062	12,220	1,172
Total	6,535,300	52,251	1,162,500	8,272	952,465	85,000

CXXXVI REPORT OF COMMISSIONER OF FISH AND FISHERIES.

Summary by fishing-grounds of certain fishery products landed at Boston, Mass., in 1896
by American fishing vessels—Continued.

Fishing-grounds.	MackereL.				Other fish.		Total.	
	Fresh.		Salted.		Pounds.	Value.	Pounds.	Value.
	Pounds.	Value.	Pounds.	Value.				
East of 66° W. longitude								
La Have Bank							3,004,950	\$95,477
Western Bank							748,070	23,744
Cape Shore	79,450	\$7,140	248,200	\$14,439			2,131,850	57,692
Gulf of St. Lawrence			30,000	1,650			30,000	1,650
West of 69° W. longitude								
Browns Bank							1,543,450	31,637
Georges Bank	461,545	42,090	138,000	9,661	946,260	\$30,571	17,591,730	360,210
Cashes Bank							1,366,400	21,621
Clark Bank							142,400	3,555
Pippenies							107,100	3,351
Ipswich Bay							40,000	825
Jeffreys Ledge					1,200	86	2,561,050	50,716
Middle Bank	50,425	2,563			1,025	130	3,074,250	61,583
Race Point							23,200	713
Off Highland Light							1,992,500	30,735
Off Chatham	1,000	45					1,512,500	25,982
South Channel	53,900	4,770	12,000	780	15,400	375	13,959,050	248,088
Nantucket Shoals	3,150	315					4,091,650	76,700
General shore grounds	412,187	26,933	827,900	34,470	524,085	14,435	9,008,302	214,715
Total	1,061,657	83,862	1,250,100	61,009	1,488,870	45,597	63,070,352	1,284,994

Following is a condensed comparative statement of the fishery products brought into Gloucester and Boston by American fishing vessels in each of the four years ending 1896. Each important species is shown separately, the weights representing the fish as they are landed from the vessels, in a fresh or salted condition. The catch of cusk and hake was much less in 1896 than in any of the other years; that of cod was less than in 1894 or 1895, but more than in 1893; that of haddock was markedly less than in the two preceding years and somewhat less than in 1893. The yield of mackerel was larger in 1896 than in any of the other years shown, and that of halibut and pollock presented no special change. The aggregate catch in 1896 was nearly 12,000,000 pounds less than in 1893, over 36,000,000 less than in 1894, and nearly 20,000,000 less than in 1895, with a corresponding decrease in values.

Species.	1893.	1894.	1895.	1896.
	<i>Pounds.</i>	<i>Pounds.</i>	<i>Pounds.</i>	<i>Pounds.</i>
Cod	54,627,104	63,599,830	67,298,639	59,487,659
Cusk	9,283,370	10,645,640	6,821,320	3,627,180
Haddock	33,008,780	45,611,956	41,005,780	30,167,286
Hake	19,091,600	23,343,816	15,340,770	10,544,420
Pollock	3,614,626	2,181,221	2,478,324	2,162,082
Halibut	9,792,911	10,905,122	9,722,342	10,895,147
Mackerel	9,296,220	8,013,400	4,536,724	11,619,532
Other fish	1,881,837	2,824,033	3,565,635	2,169,860
Total	142,396,448	167,116,817	150,439,540	130,673,766
Total value	\$4,090,847	\$3,897,671	\$3,551,692	\$3,230,898

FISHERIES OF THE PACIFIC STATES.

A general canvass of the important commercial fisheries of this region, begun in May, 1896, was completed in February, 1897. Mr. W. A. Wilcox, the agent making the investigation, visited every fishing community in the coast regions and rivers (except remote points in their headwaters), and obtained statistical and other data which are embodied in an appendix to the report for 1896. The inquiry related chiefly to the calendar year 1895, but embraced a notice of the changes in the various branches of the fishing industry since the time of the last canvass, in 1892.

The extent of the industry, as determined by this investigation, is shown in the following tables. It appears that in 1895, 17,305 persons were engaged in various branches of the fisheries in California, Oregon, and Washington. Of these, over 2,000 were employed on vessels, about 11,500 in shore and boat fisheries, and 3,800 in canneries, fish-houses, etc. The investment in the fishing industry amounted to about \$7,275,000, of which \$1,380,000 represented vessels and their outfits, \$505,000 boats, about \$1,300,000 apparatus of capture, and over \$4,000,000 the shore property and cash capital. The first value of products was \$4,470,000, representing over 147,000,000 pounds of fish, crustaceans, mollusks, etc. The leading fishery product was the chinook salmon, of which 38,392,000 pounds, valued at \$1,682,000, were taken. The next in importance is the oyster, the product being valued at \$650,000.

Persons employed in the fishing industry of the Pacific States in 1895.

How engaged.	California.	Oregon.	Washington.	Total.
In vessel fisheries	1,451	92	515	2,058
In shore and boat fisheries.....	2,716	4,230	4,493	11,439
On shore.....	603	2,001	1,204	3,808
Total	4,770	6,323	6,212	17,305

Vessels, boats, apparatus, shore property, and cash capital employed in the fisheries of the Pacific States in 1895.

Designation.	California.		Oregon.		Washington.		Total.	
	No.	Value.	No.	Value.	No.	Value.	No.	Value.
Vessels	66	\$705,530	23	\$45,950	59	\$127,350	148	\$878,830
Tonnage	9,790.87		468.07		1,420.56		11,685.50	
Outfit.....		449,155		8,059		33,034		490,248
Boats.....	1,442	121,670	2,022	212,925	2,646	170,155	6,110	504,750
Apparatus:								
Seines.....	111	14,805	50	21,050	176	71,449	343	107,304
Gill nets and trammel nets.....	2,373	158,376	2,235	319,705	3,729	183,555	8,337	661,636
Pound nets and trap nets.....			178	127,700	245	181,975	423	309,675
Bag nets and paranzolla nets.....	139	5,380					139	5,380
Fyke nets.....	830	4,700					830	4,700
Keef nets.....					30	1,365	39	1,365
Minor nets and traps.....		3,898		1,255		470		5,623
Beam trawls.....	4	300					4	300
Wheels.....			33	92,800	25	71,800	58	164,600
Lines.....		18,192		8,397		22,583		49,132
Tongs, rakes, and hoes.....		558		150		2,861		3,569
Guns and spears.....		15,104		2,913		5,752		23,769
Shore property.....		659,830		803,048		473,020		1,936,498
Cash capital.....		454,800		993,500		678,500		2,126,800
Total.....		2,012,298		2,637,412		2,024,469		7,274,179

CXXXVIII REPORT OF COMMISSIONER OF FISH AND FISHERIES.

Products of the fisheries of the Pacific States in 1895.

Species.	California.		Oregon.		Washington.		Total.	
	Pounds.	Value.	Pounds.	Value.	Pounds.	Value.	Pounds.	Value.
Catfish.....	276,005	\$3,905	99,390	\$1,347			376,004	\$5,312
Cod.....	2,783,550	83,508			484,250	\$13,934	3,267,800	97,440
Cultus-cod.....	139,495	4,213	6,000		223,278	4,193	368,773	8,646
Flounders.....	3,308,334	69,095			106,850	1,502	3,415,184	71,497
Halibut.....			5,000	400	1,714,815	39,418	1,719,315	39,818
Herring.....	3,180,960	24,360			344,670	2,201	3,525,630	26,561
Rockfish.....	1,527,344	31,033	37,000	1,780	38,420	798	1,602,764	33,600
Salmon, blueback.....	192,000	4,800	565,913	18,315	7,292,588	166,818	8,050,501	189,933
Salmon, chinook.....	4,398,044	126,601	21,056,926	977,001	12,936,888	574,975	38,391,856	1,079,477
Salmon, dog.....			2,125,115	10,627	5,471,897	28,956	7,597,012	39,583
Salmon, humpback.....					2,269,768	15,326	2,269,768	15,326
Salmon, silver.....	164,413	4,403	9,457,355	142,143	12,361,721	141,460	21,883,489	288,006
Salmon, steelhead.....	461,225	18,449	3,220,324	80,825	4,071,385	135,040	8,652,934	234,314
Smelt.....	1,739,600	53,303	31,125	1,245	528,455	7,709	2,299,180	62,254
Striped bass.....	252,454	13,037					252,454	13,037
Sturgeon.....	299,729	8,393	956,236	23,707	1,883,543	47,834	3,139,511	80,094
Other fish.....	4,781,467	86,144	125,246	1,252	245,480	6,983	5,152,193	93,379
Oysters.....	14,727,240	539,497	88,800	2,220	6,484,035	109,232	21,300,075	650,949
Clams.....	1,582,859	15,457	280,700	2,475	1,405,000	8,550	3,268,959	26,482
Abalones.....	302,292	7,173					302,292	7,173
Other mollusks.....	520,500	5,531			23,650	208	544,240	6,739
Crabs.....	2,565,000	11,750	23,520	637	163,000	4,241	2,751,520	66,628
Spiny lobster.....	558,054	12,575					558,054	12,575
Crawfish.....			58,970	3,369			58,970	3,369
Shrimp and prawn.....	5,425,000	162,749			30,088	1,804	5,461,088	164,553
Terrapins, turtles, and frogs.....	144,566	21,606	4,000	400			148,566	22,006
Fur-seal, sea-lion, and sea-otter pelts.....		120,091		13,093		86,201		219,445
Whale oil.....	549,517	19,944					549,517	19,944
Other oil.....	4,500				104,250	4,865	108,750	5,045
Whalebone.....	98,517	287,227					98,517	287,227
Algae.....	20,565	531					20,565	531
Total.....	50,010,020	1,786,463	38,141,632	1,282,036	59,089,527	1,401,433	147,241,179	4,469,952

Comparing the extent of the fishing industry in 1895 with that in 1892 (the year covered by the previous canvass), it appears that 3,260 more persons were engaged, \$881,515 more capital invested, and \$357,012 less products taken. Notwithstanding the decrease in the output, the canvass of 1895 showed a substantial gain in the fisheries for food products. In Washington and Oregon there was an increase of more than 1,900 persons engaged and over \$400,000 in the value of the catch in each State, with a corresponding increase in capital. This gain was chiefly in the salmon fishery. The building of cold-storage plants has also largely increased the utilization of fresh salmon, of which extensive shipments have been made to Eastern States as well as to European countries.

In the varied fisheries of California there have been more marked changes. In some sections the food-fish fisheries show large gains, San Diego and Los Angeles counties especially having greatly increased their fishing business by building up a trade with the interior States of the Southwest. San Francisco continues to be the chief center for the reception and distribution of a vast amount of canned, dried, pickled, and fresh fish, besides the products of the whale and seal fleets. The decline in the yield of whales and seals has been marked, amounting to nearly \$1,000,000 compared with 1892; the number of vessels engaged becomes less yearly; some vessels are lost, some are not put in commission, and there are no new additions to the fleet. This branch may be expected to still further decline.

REPORT OF COMMISSIONER OF FISH AND FISHERIES. CXXXIX

The canning of salmon is the most important industry depending on the fisheries. In 1895 there were 47 establishments in operation. These employed over 33,300 persons, and represented an investment of more than \$2,760,000. The fresh salmon utilized amounted to 64,648,000 pounds, for which \$1,968,000 was paid. The canned goods comprised 955,000 cases, holding 48 one-pound cans or the equivalent, the market value of which was \$4,224,000. The extent of this industry in each State is outlined in the following table:

Summary of the salmon-canning industry of the Pacific States in 1895.

States.	Persons employed.	No. of canneries.	Value.	Cash capital.	Total investment.	Salmon utilized.		Salmon canned.	
						Pounds.	Value.	Cases.	Value.
California....	198	4	\$62,000	\$94,000	\$126,000	1,906,525	\$52,091	29,035	\$128,632
Oregon.....	1,960	26	719,225	942,500	1,061,725	35,299,241	1,184,029	525,839	2,458,698
Washington..	1,146	17	374,650	601,000	975,650	27,441,724	731,922	400,752	1,638,938
Total...	3,304	47	1,155,875	1,607,500	2,783,375	64,647,490	1,968,042	955,626	4,224,268

LOBSTER INQUIRIES ON THE PACIFIC COAST.

As noticed in the last report of the division, some special inquiries relative to eastern lobsters on the Pacific coast were begun by the writer in the latter part of the fiscal year 1895-96. The inquiries were especially addressed to the region of Monterey Bay, where the largest plants of adults, young, and eggs had been made in 1888.

The supposed capture of lobsters in this locality has from time to time been reported, but no specimens have ever been seen by persons competent to identify them. No apparatus adapted to the taking of the eastern lobster is used here or elsewhere on the western coast where lobsters have been planted, and the absence of results may represent simply a lack of knowledge.

There is a widespread belief on the Pacific coast, especially in California, that, through an oversight, the lobsters brought from the East were planted with their claws tied together, and that consequently all must have soon perished by starvation. This story, originally told as a joke at the expense of a member of the California Fish Commission, has by many come to be accepted as a fact. It is hardly necessary to say that there is absolutely no foundation for the rumor; the lobsters were not tied in any way whatever during transportation from the East, and they were deposited under the most favorable conditions.

While at San Pedro, Cal., in June, 1896, the writer secured 3 lobster traps that had been constructed by an eastern lobster fisherman some years before. These had been set for the spiny lobster, but had been discarded as being non-effective for that species. The traps were sent to Monterey for the purpose of setting them in that bay for eastern lobsters. After securing the services of a local boatman and fisherman, there was begun a series of trials for lobsters in various parts of the bay. Fresh rock-cod and flounders were used for bait and the lobster traps were rigged and set as on the New England coast. The experi-

ments were continued for seven days in June. During that time the traps were set once or twice daily in water from 18 to 125 feet deep, on rocky and sandy bottoms, at distances from the shore varying from 100 feet to $1\frac{1}{2}$ miles. The ground covered was from one-half mile off Pacific Grove to the Hotel Del Monte wharf. The conditions seemed favorable for the existence of lobsters, the bottom consisting of rocky ledges, loose rocky patches, and hard sand, with giant kelp and other vegetation. Sometimes the traps were left down 24 hours; sometimes they were lifted in 7 to 12 hours. The results, so far as lobsters were concerned, were entirely negative. Sometimes the traps were empty, with bait unmolested; sometimes the bait would be taken, with no clew to the animal removing it; but generally the traps contained starfish, rock-crabs, and spider-crabs, often in large numbers. On one occasion a trap was completely filled by an octopus, which had insinuated its body between the slats and whose arms projected from the sides of the trap.

As much time was given to the experiment as could then be properly devoted to it, but the trials should be continued with more traps and in other parts of the bay before the absence of lobsters is conceded. No evidence of the presence or absence of lobsters in the region may be expected of the fishermen, as they set no apparatus in which a lobster is apt to be caught.

Several other reports of the capture of lobsters in Monterey Bay have been made to the writer. Mr. R. Duarte, a fish-dealer of Monterey, states that about January, 1896, while in the Chinese village near Monterey, he saw a large lobster that a Chinese fisherman had snagged on a trawl line. He engaged to take it for 25 cents, but during a short absence the Chinaman became suspicious that it was unlawful to sell it and made away with it. It weighed between 5 and 7 pounds, and Mr. Duarte is confident it was an eastern lobster. No spiny lobsters are caught here. Mr. James McMann, superintendent of a fish-cannery at San Pedro and formerly of Maine, states that in 1893 he saw a lobster at Monterey that he is confident was a genuine eastern lobster; it was 6 inches long.

Inquiries relative to the lobsters planted off the Oregon and Washington coasts elicited only negative information.

In July, 1896, the Canadian Fisheries Department had a consignment of eastern lobsters planted on the coast of British Columbia. The shipment was in charge of Mr. C. A. Stayner, inspector of lobster fisheries, and consisted of 600 adults and 2,000,000 eggs; some of the lobsters weighed 10 pounds. All but 196 died in transit; the survivors were deposited in deep water at Nanaimo, Vancouver Island, on the Strait of Georgia, the eggs being planted near Vancouver, on the mainland. Mr. Stayner reports that about September 1 a lobster was caught at Victoria and fully identified. Victoria is on Fuca Strait, on the southern side of Vancouver Island, and about 80 miles from Nanaimo. The opinion of the local government fishery inspector is that the lobster was a representative of plants made by this Commission in Puget Sound in 1889, but the matter can not be definitely decided.

STRIPED BASS IN CALIFORNIA.

In the summer of 1896 the writer made some special studies of the striped bass in the waters of California, supplemental to the inquiries carried on in 1894, an account of which has been published by the Commission.*

Distribution.—The striped bass continues to be most numerous in San Francisco Bay and its tributaries; it is also taken in small numbers in Monterey Bay, and regularly ascends the coast as far as Russian River, which stream it enters. A few have been taken as far south as Los Angeles County. Up to 1896 Russian River was the supposed northern limit of its range, but in February of that year two medium-sized bass were taken in the Gualala River, which divides Sonoma and Mendocino counties and is nearly 100 miles north of Russian River. From time to time in 1896 small shipments of striped bass reached the San Francisco market from Alviso, in Santa Clara County; these were taken in the sloughs which connect with the extreme southern end of San Francisco Bay, into which they are supposed to run for the purpose of spawning. This is the first year the species has been reported from this locality. Very few are caught at Sacramento, and none in salmon gill nets; the few obtained are taken in seines hauled on the bars for catfish. They are found from June to October. In weight they range from 4 to 10 pounds, no large fish being observed.

Abundance.—The abundance of this fish in the San Francisco Bay region is remarkable and shows no signs of diminution; in fact, the receipts in the markets have been steadily increasing from year to year, and 1896 showed a large gain over 1895. The increased catch is due entirely to increased abundance, and does not represent more active fishing operations or the employment of more apparatus; on the contrary, it is probable that less fishing is now done than formerly, when the good prices received for bass were an incentive that is now lacking.

In April, 1896, a deputy of the California Fish Commission seized a lot of nets that had a mesh below the size permitted by law. They had been set in Honker Bay, an arm of Suisun Bay, and consisted of 200 fathoms of 5-inch gill net and about 180 fathoms of trammel net, all belonging to one fisherman. The nets, when seized, had a large number of striped bass in them, weighing from $7\frac{1}{2}$ to 25 pounds, and averaging 10 or 12 pounds. The deputy making the seizure reports that about 465 fish were taken out and given away, the total catch thus being not less than 5,000 pounds.

So abundant was the fish in the Sacramento-San Joaquin delta in the spring of 1896 that one salmon fisherman reported that "the spring run of salmon this year was all striped bass." In the fall of 1895, while fishing for salmon off Sherman Island, in the San Joaquin River, this fisherman had the following experience: He had set a large-

* A review of the history and results of the attempts to acclimatize fish and other water animals in the Pacific States. By Hugh M. Smith, M. D. Bull. U. S. F. C. 1895, pp. 379-472.

meshed salmon gill net near one of the breaks in the island, through which the water pours from a tule lake. No salmon had been caught, and he was taking the empty net into his boat (having stowed fully half of it), when suddenly the water was churned into foam near his boat and around his net by a school of striped bass that had evidently just come out of the tule lake. He realized that a large number of fish had struck his net and set about to secure them. One end of his net was close to shore, and he hailed some fishermen on the bank, who began to lift that end of the net, throwing the fish on land, while he emptied the other end into his boat. The catch consisted of 700 fish of nearly uniform size, and averaged 30 pounds each. This fisherman states that if his whole net had been out he would probably have lost all or part of it from the weight of the fish. This catch of 21,000 pounds was sold at less than 5 cents a pound, in San Francisco.

Grounds, movements, spawning, etc.—Evidence is accumulating to show that the striped bass remain in the tule lands for long periods, or, at least, do not move to and from salt water, as they do on the Atlantic coast. Schools are often found in the delta, and large catches are made without any fish having been caught below, and the fishermen think the fish have suddenly emerged from some tule lake. The opinion is entertained that the striped bass often become landlocked in the tule lakes, to be liberated by some freshet or high tide, thus explaining their sudden occurrence in a certain place when nets above and below have taken none. Above the Strait of Karquines the fish are usually of uniform size in the different schools, while in the straits they are apt to vary. Large catches are often made at the outlets of the tule lakes.

With few exceptions, the food of the striped bass in the fresh waters consists of carp.

Additional information has been obtained indicating a protracted spawning period for the fish on the California coast. On June 4, 1896, a 15-pound striped bass, examined by the writer in the San Francisco market, was found to be a nearly spent male from which ripe milt was running. On July 3 both male and female ripe fish (sent from Benicia) were observed in the San Francisco market. In October, 1895, a San Joaquin River fisherman, while taking a bass from a salmon net, observed a large quantity of ripe eggs to fall into the bottom of his boat.

The present abundance and rate of increase of striped bass in California render almost unnecessary at this time the consideration of the question of their artificial propagation. It can not be said that those now taken form a large part of the run. Few persons fish especially for them, the largest part of the catch being taken incidentally in salmon nets. When the conditions change, as they probably will in time, the artificial propagation of striped bass in California may become desirable.

Striped bass trade of San Francisco.—Practically the entire catch of striped bass is consigned to the San Francisco dealers, whose receipts afford an accurate basis for determining the catch. Their receipts during recent years have increased almost 100 per cent annually, and in 1896 amounted to about 364,000 pounds.

REPORT OF COMMISSIONER OF FISH AND FISHERIES. CXLIH

The following table shows the number of pounds of striped bass handled in San Francisco in 1893, 1894, 1895, and 1896:

Statement by months of the pounds of striped bass handled by San Francisco dealers in 1893, 1894, 1895, and 1896.

Months.	1893.	1894.	1895.	1896.
January	3, 448	14, 177	28, 328	27, 179
February	3, 087	12, 572	15, 611	36, 107
March	5, 403	9, 002	11, 281	38, 340
April	8, 351	9, 638	22, 000	41, 740
May	7, 232	9, 413	12, 659	45, 903
June	4, 353	4, 820	11, 532	15, 047
July	2, 950	7, 521	13, 782	13, 531
August	2, 655	6, 863	12, 419	15, 574
September	8, 507	10, 218	21, 063	24, 214
October	6, 820	23, 192	28, 724	40, 704
November	10, 473	17, 950	50, 245	40, 089
December	17, 514	24, 631	24, 653	25, 319
Total	80, 793	149, 997	252, 177	363, 747

Receipts in 1890, 5,000 pounds; in 1891, 25,000 pounds; in 1892, 50,000 pounds (estimated).

The prices received by the fishermen did not average more than 5 cents per pound in 1896, and at times were much lower. In April, for instance, only 3 cents a pound could be obtained.

SHAD ON THE PACIFIC COAST.

Distribution, abundance, etc.—Inquiries by the writer in 1896 disclosed the fact that the shad is becoming more evenly distributed along the Pacific coast of the United States, although the San Francisco Bay region and the Columbia River are still the centers of greatest abundance. The fish seems to range regularly as far south as Los Angeles County, Cal., and as far north as Stikine River, in southeast Alaska. Following are a few special notes regarding the shad's distribution and abundance supplemental to the information given in the report* based on an examination of this subject in 1894:

In April, 1895, a 5-pound shad was caught in a seine in San Pedro Bay, Los Angeles County, Cal., and three or four others were taken during the same year at San Pedro. In Monterey Bay this fish is found from August to December. It is taken chiefly in gill nets having a 3 to 4 inch mesh set for perch and horse-mackerel (*Trachurus*). Shad are very abundant in the bay and are increasing yearly. In that part of the bay adjacent to Santa Cruz and Capitola they are more numerous than at Monterey. There are some small fresh-water streams near Santa Cruz which may attract them. It is reported that a good many 7 to 9 pound fish are taken in that section, while the average for the bay is only 5 pounds.

In the vicinity of Sacramento, shad are taken mostly in April and May, although some are caught in June and a few throughout the summer and fall months. The heaviest run is in May, which is the

* Bull. U. S. F. C. 1895, pp. 379-472.

spawning time; after that the fish are of poor quality. The largest shad taken in this vicinity weighed 8 pounds, and 5 to 7 pound fish are not rare. The fish-dealers of Sacramento obtain all the shad they can handle from salmon fishermen, in whose nets the shad are snagged by being caught by their maxillary bone, the mesh of the nets being too large for the shad to gill. Shad now ascend the Sacramento as far as Chico, about 120 miles above Sacramento. They were caught there in large numbers in dip nets in June, 1896, and it is probable that they have pushed their way for a considerable distance beyond Chico.

In the Columbia River the shad is extremely abundant, and was perhaps more numerous in 1896 than in any previous year. Its movements in this river conform with those on the Atlantic coast; that is, there is a definite run into the river for spawning purposes. The fish are in greatest numbers in May and the first half of June. In the region of the Cascades but few are caught in July, and none in August. Here, in the season of 1896, the fish was more abundant and larger than ever before.

Shad are taken in salmon wheels in the vicinity of the Cascades. In May, 1896, 200 were caught in one wheel in a single day. The largest ever seen here weighed 7 or 8 pounds, the usual weight being from 4 to 6 pounds.

Near the mouth of the river shad are taken in salmon traps from early spring to the end of the fishing season, probably more being caught in June than in any other month. Examples weighing as much as 7 pounds are not infrequently taken, although the average in trap nets is only about 4 pounds. Usually only 3 or 4 are taken at each lift of the net, but sometimes 30 or more are obtained. A great many shad too small to mesh are seen in the traps. In May, 1896, 7 of the largest brought in by the Ilwaco trap fishermen on one day ranged in weight from 7½ to 11 pounds. The 11-pound shad was the largest ever observed on the Columbia of which any record may be had.

In a salmon seine at Wallace Island, Columbia River, in May, 1896, from one to two thousand shad were sometimes caught daily in six or eight hauls, and in another seine operated 15 miles below Mapledell, Oreg., 15,637 pounds were caught and marketed in the same month. In 1895, between April 25 and July 13, a salmon seine at Quinn, Oreg., took 25,791 pounds of shad, that were shipped to Portland, and in the following year, between April 13 and June 17, the same seine took 22,792 pounds.

The monthly catch was as follows:

Months.	1895.	1896.
April.....	1,304	2,630
May.....	14,070	15,335
June.....	9,807	4,818
July.....	1,110	
Total.....	25,791	22,792

Shad are numerous in most of the rivers and bays on the coast of Washington. Many have been taken in Chehalis River, in tributaries of Willapa Bay, and in Grays Harbor. Mr. A. B. Alexander reports that shad have made their appearance in considerable numbers in the vicinity of Point Roberts. At almost every lift of the salmon traps during the summer of 1896 from 30 to 40 shad were taken. One trap lifted in Mr. Alexander's presence in July contained 55; their average size was about 3½ pounds, but several weighed fully 5 pounds apiece. There is little or no demand for them, and those caught are returned to the water. At the present rate of increase it will be only a short time when the waters of Puget Sound will teem with this fish.

In July, 1887, Capt. D. Markham, of Ilwaco, Wash., while experimenting with salmon traps just below the mouth of the Stikine River, Alaska, caught a dozen shad.

Commercial value of shad.—The prices received for shad by the California fishermen in 1895 and 1896 rarely reached 5 cents a pound, and were usually much lower. In April, 1896, many hundred pounds consigned to the San Francisco market brought only $\frac{1}{10}$ cent or 1 cent a pound, and even these prices were maintained only by restricting the catch. In Monterey Bay about 75 per cent of the catch goes to San Francisco. The fish sold locally bring the fishermen 3 to 6 cents a pound, but sometimes the prices fall very low, and a box of 100 or 125 pounds of shad will often yield only \$1. At Sacramento there is little sale for shad. They bring the fishermen only 2 to 2½ cents a pound at the height of the season, and retail for 4 or 5 cents a pound.

The quantity of shad handled by the San Francisco dealers in 1894 was much less than in 1893. The receipts in 1895 were but little more than half those in 1894, but 1896 showed a large gain over both 1894 and 1895. Mr. John P. Babcock, the chief deputy of the California Fish Commission, thinks that the decline noted between 1893 and 1895 was more apparent than real, owing to the fact that in recent years the practice has been growing among dealers of buying directly from the fishermen at the city wharves, of which receipts no full account is kept.

The following statement, taken from the books of the San Francisco dealers who purchased directly from the fishermen, shows by months the quantities of shad handled in 1893, 1894, 1895, and 1896:

Months.	1893.	1894.	1895.	1896.
January	<i>Pounds.</i> 6, 588	<i>Pounds.</i> 41, 266	<i>Pounds.</i> 369	<i>Pounds.</i> 4, 800
February	19, 185	11, 707	2, 196	8, 090
March	19, 546	17, 747	14, 257	14, 353
April	32, 389	39, 115	23, 960	65, 625
May	80, 557	57, 823	36, 729	85, 392
June	30, 184	22, 027	26, 787	38, 020
July	3, 319	7, 941	3, 213	18, 151
August	2, 796	2, 020	805	3, 527
September	698	475	3, 317	9, 264
October	53, 052	24, 229	5, 788	5, 383
November	96, 340	38, 110	23, 534	24, 926
December	77, 882	8, 278	0, 534	20, 404
Total	420, 136	270, 807	140, 309	306, 246

In the Columbia River shad will bring the fishermen 3 or 4 cents a pound early in the season, but in the middle of the season the price drops to 1 cent, and even at that price the demand is limited. The absence of a good market necessitates the throwing away of far the larger part of the catch. The fishermen save a few for home consumption and for the use of their neighbors. The shad is regarded as a good fish and is much liked, but it can not compete with salmon as a marketable species.

A few shad have been canned on the Columbia River for experimental purposes and home consumption. Mr. M. J. Kinney, of Astoria, in 1895 canned shad for winter use on his own table. He states that they were very good, but of course lacked the color and oil which add to the value of the canned salmon.

REPORT ON THE WORK OF THE STEAMER ALBATROSS.

[Abstract.]

BY LIEUT. COMMANDER J. F. MOSER, U. S. N.

During the first part of the fiscal year, until December 15, the *Albatross* was employed in fur-seal investigations, under direction of the Treasury Department. After an extensive cruise in the North Pacific Ocean, Bering Sea, visiting the different seal islands, she returned via Japan and Honolulu. The vessel was relieved from duty under the Treasury Department December 15, and the latter part of the year was engaged in fishery investigations off the coast of southern and central California until May, when preparations were made for an examination of the streams of southeast Alaska, to determine their fishery resources.

During the year there were 153 days spent at sea underway and in open anchorages, and 13,925 miles were steamed by log. The want of reliable charts for navigation on the Asiatic coast was felt, and, incidentally to the regular work of the vessel, many hydrographic omissions and errors were noted and corrected. Attention is called, in the report of the vessel work, to the many doubtful islands, reefs, and shoals on or near the regular tracks of vessels between Yokohama, Honolulu, and San Francisco. Hydrographic notes and observations, particularly of the Robben and Kuril islands, were compiled which, accompanied by photographs and sketches, have been transmitted to the office of the U. S. Coast and Geodetic Survey.

The itinerary of the vessel was as follows:

Dutch Harbor, Unalaska.....	July 2-6	Honolulu Harbor, Oahu Island, Hawaii, Nov. 7-30	
Pribilof Islands.....	July 8-19	Sausalito Harbor, California.....	Dec. 11-30
Dutch Harbor, Unalaska.....	July 20-23	San Diego Bay, California.....	Jan. 1-Apr. 5
Commander Islands.....	July 30-Aug. 9	Santa Catalina Island, California.....	Apr. 6-10
Petropaulski Harbor, Kamchatka.....	Aug. 11-10	Monterey Bay, California.....	Apr. 11-24
Kuril Islands.....	Aug. 22-26	Sausalito Anchorage.....	Apr. 25-May 8
Robben Island, Okhotsk Sea.....	Aug. 28-Sept. 1	Ports on Puget Sound, Washington....	May 14-30
Shana Anchorage, Kuril Islands.....	Sept. 4-6	Ports and anchorages in British Colum-	
Hakodate Harbor, Yezo Island, Japan, Sept. 10-19		bia and southeast Alaska.....	June 1-30
Yokohama Harbor, Japan.....	Sept. 22-Oct. 22		

The commission appointed by the President in June, 1896, to investigate the condition of the fur-seal herds of the Pribilof, Commander, and Kuril islands consisted of Dr. David Starr Jordan, of Leland Stanford Junior University; Mr. Leonhard Stejneger and Mr. F. A. Lucas, of the United States National Museum; Lieut. Commander Jeff. F. Moser, U. S. N., commander of the steamer *Albatross*; Mr. O. H. Town-

send, naturalist; Col. Joseph Murray, special agent of the Treasury, and Mr. G. A. Clark, secretary. The report covering their work will be made by that commission. All the commissioners visited the Pribilof Islands, and Dr. Stejneger and Lieut. Commander Moser were instructed to visit the Asiatic side, the former being detailed to make the report.

Submitted herewith are extracts and tables from the report of Lieut. Commander Moser covering the subsequent work of the vessel:

PACIFIC COAST FISHERIES.

In summing up the work of this vessel for the six months ending June 30, 1897, that part relating to the salmon and halibut fisheries of Alaska, which commenced June 6, forming part of the work for the summer and fall, will not be referred to, but left for the full report for the six months ending December 31, 1897. The fisheries in the vicinity of Santa Catalina Island and the salmon trials with deep-sea gill nets will here be chiefly considered.

Under instructions of March 24, the *Albatross* was directed to examine the shelf surrounding the island of Santa Catalina with reference to its fishing resources. This island lies 18 miles south of Point Fermin (San Pedro) and is separated from the mainland by the San Pedro Channel. Its extreme length is $18\frac{1}{2}$ miles in a general east-and-west direction, extreme breadth 7 miles, average width 4 miles, and length of shore line about 45 miles. It is mountainous, with precipitous slopes, the highest peak reaching an altitude of 2,109 feet. About 6 miles from the extreme western end a break occurs in the mountain system connecting the two parts by a very narrow isthmus about one-half mile long, which gives it the appearance of two islands when approaching from the northward. There are several coves in which large vessels may find a lee, but no harbors for an all-around protection. The precipitous character of the shore line is sufficient indication that the shore shelf is narrow. The 50-fathom curve is nowhere more than $2\frac{1}{2}$ miles from shore, and generally within a mile, while the greatest distance of the 100-fathom curve, so far as the hydrography has been developed, is less than 4 miles.

The character of the bottom generally is mud, with areas of mud and sand, or mud and shells, or all combined. At a few points outside of the immediate shore line and off the eastern and southeastern parts of the island small areas of rocky bottom are found.

The visit of the *Albatross* during the first part of April was at a period when the migratory fishes had not yet appeared, or at least the advance guard of a few species had only commenced to run. I can therefore only speak of what might be termed the winter or early spring fishing. From the morning of our arrival at Isthmus Cove, April 6, to the morning of departure, April 10, the drag seines, gill nets, trawl lines, hand lines, and beam trawl were constantly used whenever practicable, in depths varying between a few fathoms to 130 fathoms. The principal stations were made at Isthmus Cove and vicinity, in Catalina

Harbor—in the vicinity of Dakin Cove (Avalon) to 86 fathoms, off the southeast end to 50 fathoms, and off the south end to 132 fathoms. The results are appended in detail by stations. The largest catches were made with the drag seine, large numbers of smelt and small herring being taken; with other gear the results were disappointing.

At Avalon, one morning, some 25 or 30 wall-eyed mackerel (*Scomber colias*) and about a dozen rockfish (*Sebastes*) were taken with the triple mesh gill-net; a few yellow-tails had also recently been taken. Hand-line fishing off the eastern end of the island did not meet with much success, but south of the island, off what is known locally as Silver Cañon, where the chart has character of bottom marked "rocky," we took by hand lines, in depths ranging from 90 to 132 fathoms, a large number of rockfish (*Sebastes*), the largest weighing 8 pounds.

The fishing here is entirely in spots: As the vessel drifted over a favorable locality, probably a small, exposed rock area, as many as five rockfish would be taken on one line. A few minutes afterwards the place would be passed, and then a long wait until we drifted over another spot. All the places were visited that are known locally as good fishing-grounds around the island, but so far as could be ascertained there are no large fishing-banks on the shore shelf of this island. On the south and southeast sides are a few small, rocky patches in deep water, 80 to 130 fathoms, where if one knows the exact ranges—a ship's length makes a difference—a person desiring to handle 100 or more fathoms of line can obtain several varieties of fish in large numbers. The visitor to the winter resort at Avalon can go to these spots and get a "good day's fishing," and the small village at that point can also be supplied, but the grounds could not be relied upon for large markets.

Migratory fishes come to these shores during the spring and summer in large numbers for spawning, and the summer visitor finds many different species in abundance. During our visit, smelt, small herring, and anchovies were plentiful, the seine bringing in large numbers; and the local authorities stated that a little later all the fishes so well known in these waters would be abundant, such as mackerel (*Scomber colias*), yellow-tail (*Seriola dorsalis*), bonito (*Sarda chilensis*), albacore (*Germo alalunga*), barracuda (*Sphyrna argentea*), etc.

The fisheries around Santa Catalina Island are not vigorously prosecuted; there are a few fishermen at Avalon who supply the local demands, and a few more at Isthmus Cove who ship occasionally to San Pedro. These latter were engaged in setting pots for the spiny lobster during our visit, and making some preparations for summer fishing. The demand for fresh fish by neighboring cities on the mainland is easily met by local fishermen, and as the demands become greater this island may supply a larger amount during the summer season. When the sardine cannery at San Pedro is running, large hauls are made on this side of the channel, and no doubt fish of different species can be taken here in sufficient numbers for canning or salting, but the supply near the large cities is ample to meet their wants.

The fishing methods in this vicinity have been fully described in previous publications of the Fish Commission, and therefore need not be referred to again.

The *Albatross* arrived at Santa Cruz, Monterey Bay, at midnight of April 11, and commenced a series of investigations off Monterey Bay and the Golden Gate with a view of determining the grounds resorted to by salmon while at sea, and all the attending conditions. The stations were selected with special reference to the character of the bottom, and as net setting in such great depths was experimental, the work was commenced under 100 fathoms depth. Seven stations were made, and while the catch at each station, together with the beam-trawl hauls, is appended in detail, it may not be uninteresting to add a few remarks relating to our trials.

The stations were first selected on the chart, but before setting the nets the depth was ascertained by sounding, and, if satisfactory, one or more hauls of the beam trawl were made to test the bottom life. The first station was selected near the 100-fathom curve on the south side of the submarine gorge which penetrates the central portion of Monterey Bay, in latitude $36^{\circ} 45' 30''$ N., longitude $121^{\circ} 53' 30''$ W., at the sounding marked 127 fathoms, fine, dark sand. The lead at this point indicated soft mud. The vessel was then moved over short distances, but each sounding indicated muddy bottom. Trials with the beam trawl showed that proper bottom had been found, and two cod gill-nets were set in 68 fathoms, latitude $36^{\circ} 45' 15''$ N., longitude $121^{\circ} 53' 30''$ W., C. S. chart No. 5500. On account of a dense fog these nets were not hauled for three days, when the catch was found to be a few rockfish and dogfish. The nets were badly torn by sharks. In all our search for proper bottom conditions, the indications of mud as shown by the lead were not conclusive, for at all such stations in this vicinity and to the northward the beam trawl gave evidence of rocky bottom, either by bringing up pieces of rock or marine forms only found on rocky bottom, besides the net being torn by dragging over rocks. The shore shelf, say to 500 fathoms, appears to be boulderous or stony, generally covered or partly covered with or imbedded in mud.

Station No. 2 was in 39 fathoms, latitude $36^{\circ} 39' 30''$ N., longitude $121^{\circ} 53' 30''$ W., near sounding 38 fathoms, hard gray sand. Two surface salmon nets were set at this station and remained 18 hours without result. At a third station, in 5 fathoms, gray sand and rock, inside of Point Pinos and parallel to the beach of Pacific Grove, where 2 salmon nets were down 12 hours, only a couple of rock bass were taken.

Station No. 4 was in 278 fathoms, mud and sand bottom, in latitude $36^{\circ} 47' 30''$ N., longitude $122^{\circ} 10' 30''$ W. The beam trawl indicated very prolific life, bringing up several bushels of sea-urchins, large numbers of flounders, slime-eels, spider-crabs, starfishes, and other forms. There were many humpback whales seen in the vicinity. These nets fished 16 hours, and when hauled brought in a number of black-cod and a few dogfish, rockfish, and spider-crabs; nets very badly torn by sharks.

Station No. 5 was in 581 fathoms, mud and sand, in latitude $36^{\circ} 43'$ N., longitude $122^{\circ} 12'$ W. The beam trawl at this position brought up about a dozen large macrura, the same number of rockfish and small flounders, spider-crabs, and many other forms. Easter Sunday intervened, and as a long search had to be made to recover the station the nets were in position 48 hours, and when hauled contained a number of macrura and black-cod; nets badly torn, presumably by sharks. This station is probably the deepest gill-net station that has ever been made, and it is doubtful if macrura have ever before been gilled.

Station No. 6 was made in 56 fathoms, sand and mud, in latitude $37^{\circ} 00' 30''$ N., longitude $122^{\circ} 20' 30''$ W. The beam trawl indicated live bottom, but the nets, after fishing 40 hours, were empty when hauled. The conditions at this time were very unsatisfactory; heavy wind and sea prevailed, so that the gear could hardly be handled, but the nets were well set, for they were clear when hauled.

Station No. 7 was in 68 fathoms, in latitude $37^{\circ} 37' 30''$ N., longitude $123^{\circ} 02'$ W. The beam trawl indicated rocky bottom, the trawl net being badly cut. The gill nets fished 18 hours, and brought in large numbers of rockfish, several black-cod, ratfish, dogfish, skates, etc.

These stations were all made between April 13 and 24. En route to Alaska gill nets were set 4 miles SW. from the Tatoosh Island light (entrance to Straits of Fuca) in 77 fathoms, live bottom, as indicated by the beam trawl, and were fished for about 20 hours; they brought in 1 black-cod, 1 flounder, numerous dogfish, and (rolled up in a few fragments of what had been a net) a ground shark $10\frac{3}{4}$ feet long.

It was intended to continue this work a few days off Cape Flattery, but the weather was so unfavorable that all further trials were abandoned, and the vessel entered the sound to complete her preparations for work in Alaska.

Deep-sea gill nets, I think, can be used to 1,000 fathoms if the *proper gear and proper weather conditions are obtained*. The nets furnished the *Albatross* were not specially rigged and consisted of three salmon gill nets and three cod gill nets, all 30 yards long of 16-6 flax, and hung to 6-thread tarred manila. The salmon nets were: One 53 meshes, 6-inch; 45 meshes, 7-inch; and 40 meshes 8-inch; floats, 1 fathom apart. The cod nets were 1 each: 24 meshes, 6-inch; 21 meshes, 7-inch; 18 meshes, 8-inch; floats, 2 fathoms apart. The floats used were glass, and alternate ones on the salmon nets removed. The lower corner of the nets were anchored with 10-pound Chester folding anchors. The buoy line was 6 and 9 thread stuff and usually from a third to a half the depth of water was added to stray line. The hauling was done from boats by a small hand winch. This could have been done from the vessel by steam winch, but there was danger of carrying away the light gear, not only by the heavy strain of the winch, but by the jump of the vessel in a seaway. For hauling by steam specially heavy gear will be necessary.

The buoys were ordinary trawl-line buoys, the number increasing with the depth of the set. At 581 fathoms four buoys were used on

each line, and the line further relieved by a glass float at each 100 fathoms. The glass floats are excellent if properly made; those supplied seemed to be thin and not well sealed—about half becoming “drunken” under the pressure, and therefore useless.

The positions were obtained by sextant angles on shore objects and compass bearings, yet in several instances some difficulty was experienced in recovering the buoys. Large buoys can not be used without increasing the gear very much in weight, and it is probable if the size were very much increased the jump of the buoy in a seaway would move the moorings. A very small metal nun-buoy painted red and white, fitted with a socket for the staff of a small white flag, would be most suitable. It is true that a vessel could lie near the nets, but some method would have to be adopted to light the buoys for night work. This course would, however, be frequently defeated by the weather.

The weather on the Pacific Coast is not favorable for these investigations. The prevailing northwest winds, while not blowing a steady gale, at times approach it and send in a sea too heavy for work of this nature. When the winds slacken the fogs relieve them. Moderate and smooth seas are necessary to work the nets and use the beam trawl successfully, and clear weather to locate the positions.

The greatest enemies to the nets were found to be sharks, for which the gilled fish no doubt formed a tempting bait. A bite of the net was usually taken with the fish. In some instances the nets came up almost in ribbons, and one set was always under repairs. From 15 to 20 nets are needed in these investigations. When detained at an anchorage on account of unfavorable conditions outside, the drag seine was used, surface gill nets and hook trawls set, and boats employed in trolling and hand-line fishing.

Many fish taken by hook trawl and gill nets were found completely hollowed out, nothing remaining but the head, vertebra, and skin. This is the work of the slime eel, which, introducing itself inside the fish, sucks out the fleshy portion. A few specimens taken in the beam trawl have been preserved.

The fishermen of Santa Cruz and Monterey state that they took salmon in the bay every month during the winter of 1896-97; that the salmon follow the bait, anchovies, and sardines, and can be taken when the bait is inshore; that no salmon are taken in gill nets, but that during the summer when the run is large they take several tons a day, and all by trolling. During our visit no salmon were taken.

Referring to the investigations by deep-sea gill nets it will be seen that at every station occupied there was good live bottom, and at every set, except No. 6, fish were taken, showing that the nets were doing their work; but in no instance were any anadromous fishes captured. Judging from the forms of the bottom fish taken in the nets, the hauls of the beam trawl, the general nature of the bottom, and considering the subject of structure and pressure, it is my opinion that anadromous fishes will not be found in ocean depths.

TABLES.

1.—Record of ocean temperatures and specific gravities (surface).

Date.	Time of day.	Station.		Temperature by attached thermometer.	Temperature of air.	Temp. of specimen at time sp. grav. was taken.	Specific gravity.	Specific gravity reduced to 15° C.
		Lat. N.	Long. W.					
1890.								
July								
1	6 a. m.	53 45 00	158 40 00	47	47	59	1.0250	1.024060
1	12 m.	53 47 00	158 09 00	40	48	59	1.0252	1.024280
1	6 p. m.	53 40 00	159 22 00	40	49	59	1.0250	1.024000
1	12 p. m.	53 37 00	160 41 00	46	47	59	1.0250	1.024060
2	6 a. m.	53 35 00	162 12 00	46	47	59	1.0250	1.024060
2	12 m.	53 30 00	164 07 00	45	43	59	1.0248	1.023660
2	6 p. m.	53 46 00	165 28 00	44	43	59	1.0246	1.023660
3	6 a. m.	Dutch Harbor		46	41	59	1.0234	1.022460
3	12 m.	56 20 30	169 34 00	40	43	59	1.0246	1.023660
3	6 p. m.	54 24 15	169 08 30	45	46	64	1.0244	1.024128
24	6 p. m.	54 31 00	170 08 00	44	45	64	1.0244	1.024128
24	12 p. m.	54 40 00	171 30 00	45	44	64	1.0246	1.024328
25	6 a. m.	54 45 00	172 48 00	45	45	64	1.0246	1.024328
25	12 m.	54 40 20	174 17 00	45	47	64	1.0244	1.024128
25	6 p. m.	54 58 00	175 24 00	45	40	64	1.0244	1.024128
25	12 p. m.	54 50 00	176 38 00	46	48	61	1.0242	1.023928
27	12 m.	55 03 35	179 07 18	47	48	64	1.0242	1.023928
			East.					
27	6 p. m.	55 05 00	179 55 00	46	49	64	1.0242	1.023928
27	12 p. m.	55 07 00	178 53 00	40	46	64	1.0244	1.024128
28	6 a. m.	55 07 00	177 30 00	46	48	64	1.0244	1.024128
28	12 m.	55 05 00	176 09 00	46	48	61	1.0244	1.024128
28	6 p. m.	55 05 00	175 28 00	46	48	64	1.0244	1.024128
28	12 p. m.	55 03 00	175 15 00	40	47	64	1.0244	1.024128
29	6 a. m.	55 03 00	174 08 00	45	46	64	1.0246	1.024328
29	12 m.	55 02 20	173 15 00	46	48	64	1.0246	1.024328
29	6 p. m.	54 58 00	172 21 00	40	48	64	1.0246	1.024328
29	12 p. m.	54 55 00	171 12 00	46	47	64	1.0246	1.024328
30	6 a. m.	54 51 00	170 08 00	40	46	64	1.0246	1.024328
31	3 p. m.	Bering Island		51	47	64	1.0244	1.024128
Aug. 2	10 a. m.	Copper Island		47	46	64	1.0246	1.024328
9	12 m.	55 22 15	185 44 45	48	49	64	1.0246	1.024328
10	12 m.	54 42 30	182 55 00	51	58	64	1.0244	1.024128
10	12 p. m.	53 45 00	181 15 00	51	55	64	1.0236	1.023328
11	6 a. m.	53 17 00	180 35 00	50	53	64	1.0236	1.023328
11	12 m.	52 50 00	150 54 50	52	58	64	1.0224	1.022128
16	12 m.	Petropaulski		50	55	64	1.0184	1.018128
19	4 p. m.	Arutcha Bay		48	60	64	1.0208	1.020528
19	12 p. m.	52 04 00	158 49 00	49	54	64	1.0240	1.023728
20	6 a. m.	51 36 00	158 30 00	40	50	64	1.0240	1.023728
20	12 m.	51 15 30	157 53 30	51	54	64	1.0236	1.023328
20	6 p. m.	50 49 00	157 22 00	52	55	64	1.0238	1.023528
20	12 p. m.	50 23 00	156 53 00	48	48	67	1.0240	1.024107
21	6 a. m.	49 48 00	156 13 30	49	50	67	1.0238	1.023907
21	12 m.	49 30 00	155 21 00	45	48	67	1.0240	1.024107
21	6 p. m.	49 12 00	154 56 00	42	45	67	1.0242	1.024307
21	12 p. m.	48 43 00	154 36 00	40	44	67	1.0242	1.024307
22	6 a. m.	48 39 00	154 20 00	38	41	67	1.0242	1.024307
22	12 m.	48 34 11	153 52 00	42	44	67	1.0242	1.024307
22	6 p. m.	48 29 00	153 37 00	38	48	67	1.0242	1.024307
22	12 p. m.	48 22 00	153 20 00	43	45	67	1.0240	1.024107
23	3 p. m.	Matua Island		49	50	67	1.0240	1.024107
25	12 m.	Sundnoi Rocks		38	45	67	1.0242	1.024307
26	12 m.	Ushishir Island		39	49	67	1.0242	1.024307
26	6 p. m.	47 32 30	152 14 45	40	45	67	1.0242	1.024307
26	12 p. m.	47 38 00	151 30 00	53	52	67	1.0240	1.024107
26	6 a. m.	47 42 00	150 44 00	40	42	67	1.0238	1.023907
27	6 a. m.	47 48 00	149 30 00	47	45	67	1.0238	1.023907
27	12 m.	47 54 22	149 03 00	56	54	67	1.0236	1.023707
27	6 p. m.	48 03 00	148 00 00	53	53	67	1.0233	1.023487
27	12 p. m.	48 09 00	147 11 00	56	56	67	1.0230	1.023187
28	6 a. m.	48 18 00	146 21 00	57	57	67	1.0230	1.023107
28	12 m.	48 26 30	145 28 00	54	57	67	1.0220	1.022187
28	7 p. m.	Robben Island		58	56	67	1.0220	1.022307
30	12 m.	48 35 00	144 11 30	63	57	74	1.0222	1.022406
30	12 m.	48 46 07	144 00 17	56	56	74	1.0222	1.022406
2	6 p. m.	48 29 00	144 41 00	47	54	74	1.0222	1.022406
2	12 p. m.	47 56 00	145 13 00	65	54	74	1.0226	1.022806
3	6 a. m.	47 28 00	145 48 00	56	53	74	1.0226	1.022806
3	12 m.	46 56 27	146 22 32	57	58	74	1.0230	1.024206
3	6 p. m.	46 38 00	146 45 00	50	66	74	1.0230	1.024266
3	12 p. m.	46 18 00	147 05 00	55	53	74	1.0232	1.024466
4	6 a. m.	45 54 00	147 17 00	53	53	74	1.0230	1.024206
4	12 m.	45 31 30	147 32 30	55	58	74	1.0234	1.024066
4	6 p. m.	45 16 30	147 44 00	58	64	74	1.0234	1.024066
6	6 p. m.	45 17 00	148 51 00	58	61	74	1.0230	1.024206
6	12 p. m.	45 20 00	145 58 00	58	62	74	1.0232	1.024466
7	6 a. m.	45 24 00	145 03 00	57	60	74	1.0232	1.024466

1.—Record of ocean temperatures and specific gravities (surface)—Continued.

Date.	Time of day.	Station.		Temperature by attached thermometer.	Temperature of air.	Temp. of specimen at time sp. grav. was taken.	Specific gravity.	Specific gravity reduced to 15° C.
		Lat. N.	Long. E.					
1890.								
Sopt. 7	12 m.	45 25 30	144 04 30	56	62	74	1.0230	1.024266
7	6 p.m.	45 31 00	143 17 00	56	59	74	1.0238	1.024086
7	12 p.m.	45 35 00	142 32 00	58	58	74	1.0224	1.023666
8	6 a.m.	45 39 00	141 46 00	53	57	74	1.0228	1.024066
8	12 m.	45 28 46	141 21 00	66	64	74	1.0230	1.024266
8	6 p.m.	44 47 00	141 10 00	67	68	74	1.0234	1.024066
8	12 p.m.	44 19 00	140 42 00	68	68	74	1.0234	1.024066
9	6 a.m.	43 36 00	140 16 00	68	66	74	1.0234	1.024066
9	12 m.	42 53 35	139 54 00	68	68	74	1.0236	1.024866
9	6 p.m.	42 22 00	139 37 00	68	69	74	1.0236	1.024866
9	12 p.m.	41 25 00	139 42 00	69	69	74	1.0236	1.024866
10	6 a.m.	41 21 00	140 12 00	70	68	74	1.0232	1.024466
10	12 m.	Hakodate, Japan		68	68	74	1.0230	1.024266
20	12 m.	39 44 30	142 17 00	67	70	70	1.0240	1.024890
20	6 p.m.	38 49 42	141 56 20	68	68	70	1.0238	1.024430
20	12 p.m.	37 51 00	141 36 10	69	69	70	1.0236	1.024230
21	6 a.m.	36 53 40	141 10 00	68	68	70	1.0238	1.024430
21	12 m.	36 01 00	140 55 40	72	69	70	1.0238	1.024430
21	6 p.m.	35 24 30	140 42 30	77	72	70	1.0240	1.024630
21	12 p.m.	34 51 00	139 57 30	76	73	70	1.0242	1.024830
22	6 a.m.	Gulf of Tokio.		70	60	70	1.0202	1.020830
22	6 p.m.	34 50 00	140 35 00	73	68	70	1.0242	1.024830
22	12 p.m.	34 51 00	141 30 00	75	66	70	1.0246	1.025230
23	6 a.m.	34 50 00	142 29 00	73	66	70	1.0248	1.025430
23	12 m.	34 67 00	143 25 30	75	67	70	1.0248	1.025230
23	6 p.m.	34 44 00	144 25 00	75	67	70	1.0246	1.025230
23	12 p.m.	34 35 00	145 50 00	74	65	70	1.0248	1.025430
24	6 a.m.	34 24 00	146 51 00	74	65	70	1.0248	1.025430
24	12 m.	34 15 30	147 47 00	76	68	70	1.0248	1.025430
24	6 p.m.	34 09 00	148 56 00	75	68	70	1.0248	1.025430
24	12 p.m.	34 07 00	150 05 00	74	67	70	1.0248	1.025430
25	6 a.m.	34 05 00	151 10 00	73	66	70	1.0246	1.025230
25	12 m.	34 04 19	152 04 00	74	72	70	1.0246	1.025230
25	6 p.m.	34 02 00	153 25 00	74	70	70	1.0246	1.025230
25	12 p.m.	34 02 00	154 40 00	73	69	70	1.0246	1.025230
26	6 a.m.	34 04 00	155 38 00	73	68	70	1.0248	1.025430
26	12 m.	34 04 11	156 21 30	72	72	70	1.0246	1.025230
26	6 p.m.	34 10 00	157 42 00	70	74	70	1.0248	1.025430
26	12 p.m.	34 10 00	158 45 00	73	71	70	1.0248	1.025430
27	6 a.m.	34 20 00	159 50 00	72	72	70	1.0250	1.025630
27	12 m.	34 25 30	160 54 46	72	72	70	1.0250	1.025630
27	6 p.m.	34 25 00	161 45 00	71	74	70	1.0250	1.025630
27	12 p.m.	34 26 00	162 46 00	70	73	70	1.0250	1.025630
28	6 a.m.	34 25 30	163 50 00	71	74	70	1.0248	1.025430
28	12 m.	34 26 18	165 01 25	71	74	70	1.0248	1.025430
28	6 p.m.	34 24 00	166 10 00	71	74	70	1.0248	1.025430
28	12 p.m.	34 24 30	167 25 00	72	75	70	1.0248	1.025430
29	6 a.m.	34 24 00	168 35 00	72	74	70	1.0246	1.025230
29	12 m.	34 23 46	169 32 23	69	73	70	1.0248	1.025430
29	6 p.m.	34 24 00	170 50 00	72	73	70	1.0248	1.025430
29	12 p.m.	34 23 30	172 00 00	72	73	70	1.0248	1.025430
30	6 a.m.	34 22 00	173 20 00	73	74	70	1.0250	1.025630
30	12 m.	34 21 45	174 18 15	72	75	70	1.0252	1.025830
30	6 p.m.	34 16 00	175 45 00	70	74	70	1.0252	1.025830
30	12 p.m.	34 10 00	176 55 00	69	73	70	1.0252	1.025830
31	6 a.m.	34 02 00	178 00 00	69	72	70	1.0252	1.025830
31	12 m.	33 56 00	178 55 00	67	70	70	1.0252	1.025830
31	6 p.m.	33 40 00	179 58 00	67	65	82	1.0236	1.026200
		West.						
Nov. 31	12 p.m.	33 28 00	179 06 00	67	66	82	1.0236	1.026200
1	6 a.m.	33 18 00	178 23 00	65	66	82	1.0240	1.026700
1	12 m.	32 28 00	174 21 15	66	67	82	1.0242	1.026900
1	6 p.m.	32 00 00	173 31 00	69	65	82	1.0242	1.026900
1	12 p.m.	31 27 00	172 40 00	70	66	82	1.0242	1.026900
2	6 a.m.	30 50 00	175 31 00	72	67	82	1.0242	1.026900
2	12 m.	30 13 00	170 56 45	72	71	82	1.0242	1.026900
2	6 p.m.	29 40 00	170 10 00	72	69	82	1.0242	1.026900
2	12 p.m.	29 07 00	169 23 00	72	69	82	1.0242	1.026900
3	6 a.m.	28 35 00	168 37 00	73	68	82	1.0244	1.027100
3	12 m.	28 00 47	167 41 14	75	72	82	1.0244	1.027100
3	6 p.m.	27 40 00	166 57 00	75	74	82	1.0244	1.027100
3	12 p.m.	27 21 00	166 02 00	74	72	82	1.0244	1.027100
4	6 a.m.	26 55 00	165 19 00	75	72	82	1.0242	1.026900
4	12 m.	26 29 00	164 19 00	76	75	82	1.0242	1.026900
4	6 p.m.	26 13 00	163 38 00	76	76	82	1.0242	1.026900
4	12 p.m.	25 47 00	162 53 00	76	76	82	1.0242	1.026900
5	6 a.m.	25 24 00	161 56 00	77	78	82	1.0240	1.026700
5	12 m.	24 54 00	160 50 00	77	80	82	1.0240	1.026700
5	6 p.m.	24 21 00	160 22 00	78	80	82	1.0242	1.026800

REPORT OF COMMISSIONER OF FISH AND FISHERIES. CLV

1.—Record of ocean temperatures and specific gravities (surface)—Continued.

Date.	Time of day.	Station.		Temperature by attached thermometer.	Temperature of air.	Temp. of specimen at time sp. grav. was taken.	Specific gravity.	Specific gravity reduced to 15° C.
		Lat. N.	Long. W.					
1896.								
Nov. 5	12 p. m.	23 52 00	159 41 00	77	80	82	1.0242	1.026900
6	6 a. m.	23 27 00	159 27 00	77	79	82	1.0242	1.026900
6	12 m.	23 02 30	159 01 30	77	80	82	1.0240	1.026700
6	6 p. m.	22 31 00	158 47 00	77	80	82	1.0238	1.026500
6	12 p. m.	22 03 00	158 32 00	77	80	82	1.0238	1.026500
7	6 a. m.	21 31 00	158 18 00	77	80	82	1.0232	1.025900
7	12 m.	Honolulu, H. I.		78	81	87	1.0256	1.025767
30	12 m.	21 21 00	157 28 00	76	78	87	1.0258	1.025967
Dec. 1	12 m.	22 58 00	154 27 30	77	78	87	1.0258	1.025967
2	12 m.	24 33 10	151 19 15	75	76	87	1.0258	1.025967
3	12 m.	26 15 00	148 20 00	74	76	87	1.0258	1.025967
4	12 m.	27 47 00	145 37 00	73	75	87	1.0258	1.025967
5	12 m.	29 17 20	143 03 25	68	70	87	1.0256	1.025767
6	12 m.	30 26 00	140 09 00	69	70	87	1.0256	1.025767
7	12 m.	31 36 30	137 02 00	66	68	87	1.0256	1.025767
8	12 m.	32 53 00	133 32 00	65	69	87	1.0252	1.025367
9	12 m.	34 01 25	130 00 12	66	71	87	1.0248	1.024987
10	12 m.	35 35 45	126 17 30	60	63	87	1.0248	1.024987

2.—Record of accepted sounding stations of the United States Fish Commission steamer *Albatross* for the fiscal year ending June 30, 1897.

EASTERN PORTION OF BERING SEA SOUTH OF PRIBILOF ISLANDS.

Date.	Serial number.	Time of day.	Position.		Depth.	Character of bottom.	Temperatures.		
			Lat. N.	Long. W.			Air.	Sur-face.	Bot-tom.
1896.									
July 7	Dr. 3634	4. 14 p. m.	54 51 00	167 27 00	664	bk. vol. S.	43	43	36.3
7	Hy. 3655	8. 18 p. m.	54 51 00	167 46 00	671	gn. M. bk. vol. S.	43	43	36.4

1' FROM BERING ISLAND TO KAMCHATKA COAST.

Aug.	Hy.	Time of day.	Position.		Fms.	Character of bottom.	Temperatures.		
			Lat. N.	Long. W.			Air.	Sur-face.	Bot-tom.
9	3660	3. 05 p. m.	55 11 30	165 39 00	41	fne. gy. S. bk. Sh.	52	48
9	3661	5. 21 p. m.	55 08 30	165 26 00	2, 250	fne. gy. S. bk. P. C.	49	49	35.0
9	3662	11. 16 p. m.	54 49 42	164 36 00	2, 665	M. fne. dk. S. P. .	52	49	35.0
10	3663	5. 24 a. m.	54 51 00	163 46 00	3, 117	bn. M. fne. dk. S. .	54	49	35.2
10	3664	11. 01 a. m.	54 42 30	162 55 00	2, 077	bn. M. dk. S. P. .	57	50	35.0
10	3665	4. 20 p. m.	54 35 00	162 11 30	473	bn. M. dk. S. P. .	53	44	38.0
10	3666	5. 49 p. m.	54 32 30	161 58 30	586	bn. M. fne. S. P. .	53	44	37.4
10	3667	7. 07 p. m.	54 29 00	161 50 00	453	bn. M. dk. S. P. .	54	45	37.0

2' SOUTHEAST COAST OF KAMCHATKA.

Aug.	Hy.	Time of day.	Lat. N.	Long. W.	Fms.	Character of bottom.	Air.	Sur-face.	Bot-tom.
20	3638	10. 04 a. m.	51 17 00	158 10 00	127	gn. M. Co. dk. S. P.	53	49	32.7
20	3643	10. 43 a. m.	51 16 00	158 03 00	100	bk. S. P.	53	49	31.7
20	3644	1. 09 p. m.	51 09 00	157 48 00	96	bk. S.	60	51	33.1

3' ALONG KURIL CHAIN.

Aug.	Hy.	Time of day.	Lat. N.	Long. W.	Fms.	Character of bottom.	Air.	Sur-face.	Bot-tom.
21	3669	8. 42 p. m.	48 43 00	154 31 00	425	crs. dk. S.	44	41	36.7
22	3670	3. 32 a. m.	48 33 00	154 53 00	114	hrd.	42	37	35.7
22	3671	5. 01 a. m.	48 32 00	154 55 00	106	brk. Sh.	41	37
22	3672	11. 19 a. m.	48 36 00	153 59 00	304	crs. G.	45	42	36.7
22	3673	7. 54 p. m.	48 26 00	153 33 00	1, 102	crs. dk. S. P. .	47	45	34.7
23	3674	10. 26 a. m.	48 19 00	153 23 00	1, 001	bk. S. P.	48	44	35.7
23	3675	2. 24 p. m.	48 13 00	153 20 00	624	bk. S.	48	49	30.3
24	3676	10. 58 a. m.	47 35 00	152 48 30	96	rky.	45	38	35.7

¹ Except station Hy. 3660, geographical positions on this line are independent of shore features.

² Accepting position of Ari Kamen, Bering Island, as plotted on Stejneger's map, it bore NE. by E. 2 E. (mag.), distant 3 miles from Hy. 3660.

³ Serial temperatures to 1,000 fathoms.

⁴ 97° 33' Ext. Rt. Pt. to Cape Kosloff. 95° 08' first Pt. left of Ext. Rt. Pt. to Kosloff. 77° 02' Ext. Rt. Pt. to Mt. Kronotaki.

⁵ 102° 43' Ext. Rt. Pt. to Kosloff. 91° 03' Ext. Rt. Pt. to Kronotaki. 60° 07' Kosloff to Detached Rock.

Ext. Right Point, N. 16° E., mag. Mt. Kronotaki, N. 74° W., mag. Cape Kosloff, N. 86° 15' W., mag.

⁶ 73° 56' Ext. Rt. Pt. to Kosloff. 1° 12' Kosloff to detached rock. Cape Kosloff, N. 46° 30' W., mag.

⁷ Geographical positions, approximate, without relation to shore features.

⁸ Geographical positions, approximate, without relation to shore features, except station Hy. 3676.

⁹ Position referred to obs. spot at Old Village, Lower Ushishir Island, as in lat. 47° 30' 58.8" N., long. 152° 47' 55" E., determined by this vessel.

CLVI REPORT OF COMMISSIONER OF FISH AND FISHERIES.

2.—Record of accepted sounding stations of the United States Fish Commission steamer Albatross for the fiscal year ending June 30, 1897—Continued.

1 SEA OF OKHOTSK FROM LOWER USHISHIR ISLAND TO ROBBERN ISLAND.

Date.	Serial number.	Time of day.	Position.		Depth.	Character of bottom.	Temperatures.		
			Lat. N.	Long. W.			Air.	Sur-face.	Bot-tom.
1896.			° ' "	° ' "	Fms.				
Aug. 26	² Hy. 3679	7. 27 a. m.	47 31 30	152 45 48	37	P	45	39	38.7
26	³ Hy. 3680	8. 14 a. m.	47 31 30	152 39 00	685	P	45	40	35.7
26	⁴ Hy. 3681	9. 27 a. m.	47 31 42	152 32 00	1, 164	fne. gy. S.	44	39	35.2
26	⁵ Hy. 3682	11. 07 a. m.	47 32 00	152 21 00	1, 500	bn. M. fne. gy. S.	44	39	34.7
26	⁶ Hy. 3683	1. 22 p. m.	47 33 00	152 07 00	1, 712	fne. gy. S.	47	39	35.2
26	Hy. 3684	4. 25 p. m.	47 36 00	151 46 00	1, 830	bn. M. dk. S.	53	53
26	Hy. 3685	9. 32 p. m.	47 40 30	151 05 00	1, 836	bn. M. fne. S.	49	50	35.7
27	Hy. 3686	2. 32 a. m.	47 45 00	150 23 30	1, 836	bn. M. fne. S.	43	47	35.9
27	Hy. 3687	7. 46 a. m.	47 50 00	149 42 00	1, 843	bn. & yl. M. fue. S.	48	50	36.0
27	Hy. 3688	1. 02 p. m.	47 55 30	148 56 00	1, 562	bn. M. fne. S.	55	55	35.8
27	Hy. 3689	5. 41 p. m.	48 01 30	148 16 30	1, 426	bn. M. fne. S.	55	55	36.0
27	Hy. 3690	10. 35 p. m.	48 08 00	147 34 00	964	lt. bn. M. qtz. S.	56	56	36.0
28	Hy. 3691	3. 27 a. m.	48 15 00	146 51 00	796	lt. bn. M. qtz. S.	57	59	36.0
28	Hy. 3692	8. 02 a. m.	48 21 00	146 08 00	698	bn. M. fue. S.	58	56	36.2
28	Hy. 3693	12. 47 p. m.	48 27 45	145 20 30	155	bn. M. crs. vol. S.	58	56	33.0
28	Hy. 3694	3. 46 p. m.	48 31 48	144 54 51	27	fne. G. R. Sh.	57	48	35.0
28	Hy. 3695	5. 30 p. m.	48 29 00	144 42 30	16	rky	58	51

7 SEA OF OKHOTSK FROM ROBBERN ISLAND TO ITURUP ISLAND.

Sept. 2	Hy. 3696	5. 44 p. m.	48 22 00	144 41 00	20	fne. S. P.	55	47	40.0
2	Hy. 3697	9. 04 p. m.	48 05 00	145 01 00	71	bl. M.	54	55	31.0
3	Hy. 3698	1. 40 a. m.	47 43 00	145 28 00	631	gn. M. S.	54	54	37.0
3	Hy. 3699	6. 12 a. m.	47 20 30	145 54 00	1, 584	gn. M. fue. S.	53	50	35.9
3	Hy. 3700	11. 08 a. m.	46 58 00	146 20 00	1, 818	gn. M. fue. S.	57	58	35.9
3	Hy. 3701	4. 18 p. m.	46 35 00	146 49 00	1, 820	lt. bn. M. S.	62	55	36.0
3	Hy. 3702	9. 13 p. m.	46 15 00	147 07 00	1, 817	bn. M. fue. S.	55	55	35.8
4	Hy. 3703	2. 18 a. m.	45 48 00	147 22 00	1, 825	gn. M. fue. S.	53	54	36.0
4	Hy. 3704	4. 28 a. m.	45 40 00	147 28 00	1, 761	gn. M. fue. S.	53	53	35.9
4	Hy. 3705	6. 25 a. m.	45 31 30	147 32 30	1, 078	bn. M. fue. S.	53	54	36.0
4	Hy. 3706	8. 20 a. m.	45 23 00	147 39 30	1, 107	bn. M. fue. S.	54	54	36.0
4	Hy. 3707	9. 25 a. m.	45 18 00	147 42 00	668	bn. M. crs. S.	54	54	36.5

7 SEA OF OKHOTSK FROM ITURUP ISLAND TOWARD LA PEROUSE STRAITS.

Sept. 6	Dr. 3652	10. 00 a. m.	45 15 30	147 53 00	14	yl. C.	64	56
6	Dr. 3653	10. 30 a. m.	45 14 00	147 52 30	18	dk. gy. S.	64	57	56.5
6	Hy. 3708	10. 53 a. m.	45 10 00	147 52 00	27	dk. gy. S.	64	58	50.0
6	Hy. 3709	11. 48 a. m.	45 16 30	147 45 00	312	gn. M. fue. S.	64	58	35.7
6	Hy. 3710	1. 20 p. m.	45 18 00	147 31 00	810	gn. M. S.	60	55	36.0
6	Hy. 3711	4. 06 p. m.	45 19 00	147 09 00	1, 641	gn. M. fue. S.	60	54	36.0
6	Hy. 3712	9. 06 p. m.	45 21 00	146 27 00	1, 744	gn. M. fue. S.	60	58	35.8
7	Hy. 3713	1. 53 a. m.	45 23 00	145 46 00	1, 700	gn. M. S.	61	58	36.0
7	Hy. 3714	6. 30 a. m.	45 25 00	145 02 00	1, 649	gn. M. S.	60	57	35.9
7	Hy. 3715	10. 43 a. m.	45 27 00	144 21 00	408	gn. M. crs. S. P.	62	54	36.5
7	Hy. 3716	2. 38 p. m.	45 31 00	143 36 00	122	gy. S.	62	56	33.0
7	Hy. 3717	5. 22 p. m.	45 34 00	143 12 00	68	gn. M.	61	57	34.0
7	Hy. 3718	6. 50 p. m.	45 36 30	142 56 00	62	gn. M.	60	59	32.0

¹ Geographical positions on this line referred to obs. spot at Old Village, Lower Ushishir Island, as in lat. 47° 30' 56.8" N., long. 152° 47' 55" E. Robben Island is assumed to be in lat. 48° 31' 30" N., long. 144° 48' 38" E.

² Babuakin Rock, south (true) $\frac{1}{2}$ mile.

³ SW. end Lower Ushishir, S. 68° E., true; S. end Ketoy, S. 48° W., true.

⁴ SW. end Lower Ushishir, S. 80° E., true; S. end Ketoy, S. 28° W., true.

⁵ SW. end Lower Ushishir, S. 92° E., true; S. end Ketoy, S. 14° E., true.

⁶ Right end Ketoy, S. 44° E., true; North Ushishir Peak, S. 86° E., true.

The five preceding bearings are all independent of geographical positions of the stations and have not been adjusted.

⁷ Positions on this line are geographical without relation to shore features. Position given on B. A. chart No. 2405 of Shana Village, Iturup Island, is accepted. Lat. 45° 15' N., long. 147° 56' E.

REPORT OF COMMISSIONER OF FISH AND FISHERIES. CLVII

3.—Record of stations of the steamer Albatross where long-beam trawl was used.

Serial No.	Date.	Time of day.	Position.		Temperatures.				Character of bottom.	Wind.				
			Lat. N.	Long. W.	Air.	Surface.	Bottom.	Depth.		Direction.	Force.	Time used (minutes).		
			o	"	o	"								
			Santa Catalina Island, California.											
3662	1897. Apr. 8	11.09 a. m.	14	00	118	24	69	58	51.7	47	Fne. gy. s...	Variable.	0—1	11
3663	Apr. 8	11.39 a. m.	Near proceeding station.				69	58	52.5	47	do	do	0—1	10
3664	Apr. 8	1.30 p. m.	2' off Avalon, Dalkins Cove.				70	58	49.7	80	do	do	0—1	13
3665	Apr. 9	1.07 p. m.	33	17	00	118 24 00	76	61		59	do	do	0—1	9
			Monterey Bay and vicinity.											
3666	Apr. 13	11.02 a. m.	36	45	00	121 58 00	64	55		68	M. s. bldr ...	West ...	1—2	8
3667	Apr. 13	12.04 p. m.	36	45	00	121 52 00	64	55	47.7	90	do	do	2	12
3668	Apr. 13	2.44 p. m.	36	40	00	121 53 00	57	56	48.7	39	S. mica	W. by S.	1—2	11
3669	Apr. 16	4.48 p. m.	36	47	00	122 11 00	55	57	42.7	278	Gn. m. fno. s	SSW	0—1	15
3670	Apr. 17	11.44 a. m.	36	43	00	122 12 00	58	54	37.8	581	Gn. m. s.	Calm	0	27
3671	Apr. 21	10.52 a. m.	37	00	00	122 20 00	53	50		56	do	NW by W	5—6	15
3672	Apr. 24	10.47 a. m.	37	37	00	123 02 00	56	49	49.0	68	S. co. r.	NW	2	21
			Flattery Bank.											
3673	May 14	0.50 a. m.	48	21	45	124 50 30	54	47	45.0	77	Gn. m. s.	West	1—2	...

Results of Beam-trawl Hauls.

No. 3662.—Many flounders of 2 species, 1 quite large, many small; many small sculpins; several large holothurians; many sea-urchins, 2 species; 2 soft crabs with mossy backs; 1 naked mollusk; 1 shell with small ascidians attached; few small shells of two species; few large hermit-crabs; few brachiopods with cup-corals attached; few hard red starfish; 3 very small starfish; 2 fragments of sponge; 4 small shrimps.

No. 3663.—Several large flounders, 2 species, many young and small, several young sculpins; 1 small octopus; 1 small fish; 3 small shrimps; 1 large red holothurian; 2 hard red starfish; 1 large gray starfish; 1 very small starfish; 1 very small ophiuran; many sea-urchins of 2 species; 2 pennatula, 1 very small; 1 large worm in tube; 1 large and 3 small shells.

No. 3664.—2 large flounders of different species, few small; 1 red sculpin; several small sculpins; 2 alligator-fish; few young rockfish; 1 small blenny; many sea-urchins, 2 species; few small shrimps; 1 small hermit crab; 1 tiny spider-crab; 1 cushion starfish; several hard starfish with short arms; 1 large soft starfish; 1 large shell; few small shells; 1 holothurian; 1 naked mollusk; 1 worm; skate egg-cases, bryozoa, hydroids, etc.

No. 3665.—36 small flounders, 2 or 3 species; several flounder fry; 1 sculpin; small sculpins of several species; 1 adult and 2 small alligator-fish; few young rockfish; 1 small skate; 1 small octopus; sea-urchins, 2 species; several red holothurians; 1 hard-skinned holothurian covered with warts; 1 small ophiuran; several small starfish, 2 or 3 species; few small shrimps; 1 large worm in tube; 2 naked mollusks; 1 small sea spider.

No. 3666.—1 cultus-cod, female, 39½ inches, 21½ pounds, stomach empty; 1 cultus-cod, female, 30½ inches, 12 pounds, residue of fish well digested in stomach; 4 chinnara; 3 red rockfish; 1 skate; 3 small flounders; several young rockfish; 2 small octopus; 1 bushel large white anemones; 1 prawn; few small shrimps of 2 species; 1 each of 2 species of holothurians; 1 small crab; 1 hermit-crab; several small shells of several species; 1 small crustacean; 3 starfish of different species; many small and a few large worms and tubes; several cup-corals. A boulder the size of a hoghead, covered with anemones and cup-corals, was also brought up.

No. 3667.—8 small rockfish, of 3 species; 1 col-pout; 1 small flounder; 1 small octopus; 1 holothurian; 2 sea-urchins.

No. 3668.—1 large and few small long-finned sole; 1 small fish; few shrimps; 3 small shells of 2 species; 1 parasitic crustacean; 1 ophiuran.

No. 3669.—1 rockfish (S. ruber); 1 large skate with rockfish in stomach; 1 small skate; 15 large flounders, of 3 species; several slimy eels; 1 small pelagic fish, with very long teeth; 2 small fishes; several large and few small spider-crabs; 1 small anemone; few small medusae; several hermit-crabs; 1 barrel sea-urchin, apparently of same species; several small hard starfish; several small brittle starfish with many arms; several shrimps; 1 fragment sponge; several shells.

No. 3670.—8 maoruri, 4 male and 4 female, 1 with apparently ripe ova; 3 large flounders; many red small rockfish (probably Sebastes); several young rockfish; 1 small dusky fish, and 1 very small brilliant-scaled fish, both evidently pelagic; 6 large spider-crabs, with long thin red legs; many small ditto; 1 large crimson prawn; few small shrimps; 2 sea lice; few very small sea-urchins; 3 small starfish with many arms; 2 small starfish of different species; 2 ophiurans, 1 very small; many small shells of several species; many shells (Gasteropoda) mostly with small, red anemones attached, and a few with hermit-crabs; many small, red anemones; few small Pennatula; 2 naked mollusks; worms of several species; 4 sea mice; 1 small squid; 1 small medusa; 1 skate egg-case with anemone attached.

No. 3671.—Several large and few small flounders of 2 or 3 species; ova of larger flounders nearly ripe, showing pink through skin; few small rockfish; 3 alligator-fish; 2 young squid; 1 shrimp; few sea-urchins; several starfish; several ophiurans; several shells, 3 or 4 species; few worms and sea mice; 3 naked mollusks.

No. 3672.—4 large flounders, 2 each of 2 species; 1 small rockfish; 1 large skate; 1 alligator-fish, ova well developed; 1 small shrimp; 1 small starfish; few ophiurans; many crinoids; 2 small shells, 1 with hermit-crab; 1 sea-urchin; 1 large green worm; 2 small crabs; 1 large anemone; 1 small fragment coral.

No. 3673.—1 large barndoor skate, 8 pounds; 1 large flounder with young shrimps in stomach; 4 chinnara; 2 small alligator-fish; 2 flounder fry; 1 young squid; several shells, few with hermit-crabs; several shrimps and prawns; several ophiurans; few fragments sponge; 1 large starfish.

CLVIII REPORT OF COMMISSIONER OF FISH AND FISHERIES.

4.—Record of gill-net stations of the U. S. Fish Commission steamer Albatross.

Serial number.	Date.	Time.	Position.		Temperature.			Depth in fathoms.	Character of bottom.	Wind.			Nets set.	
			Lat. N.	Long. W.	Air.	Surface.	Bottom.			Direction.	Force.	Hours.	Number.	Kind.
			" " " " " Santa Catalina Island, California.											
	1897. Apr. 7	7 p. m.	1° 3' SE.	of Avalon, Dakins Cove.	64	58	6-10	rky.	Variable	1x	11	2	2	Menhaden. Do.
		8do	do	do	60	58	6-10	rky.	do	1-2x	9	2	2	
			Monterey Bay and vicinity.											
1	Apr. 13	10 a. m.	36 45 15	121 53 00	64	55	47.7	68	m. S. bldr.	do	0-1	70	2	Cod.
2	13	2.30 p. m. ...	36 39 20	121 53 00	57	56	48.7	39	gy. S. mica	W. & S.	1-2x	19	2	Salmon.
3	14	5 p. m.	Off Pacific Grove, Point Pinos.		60	57		5	gy. S. rky.	WNW	3-2x	13	2	Do.
4	16	4 p. m.	36 47 00	122 10 00	55	57	42.7	278	gy. m. Ino. S.	SSW	1	17	{ 1 2	Salmon. Cod.
5	17	11 a. m.	36 43 00	122 12 00	57	55	37.8	581	gy. m. S.	Variable	0-1	51	{ 1 1	Salmon. Cod.
6	21	9.30 a. m. ...	37 00 30	122 20 30	53	50		56	gy. m. S.	WNW	5	48	{ 1 1	Salmon. Cod.
7	24	10.30 a. m. ...	37 37 30	123 02 00	56	49	49.0	68	S. Co. R.	NW	2	20	{ 1 2	Salmon. Cod.
			Flattery Bank.											
8	May 14.	8.30 a. m. ...	48 21 30	124 50 15	53	48	45.0	80	gn. m. S.	W. & N.	2	22	{ 1 2	Salmon. Cod.

Sets marked x made at surface; remainder on bottom.

Results of gill-net trials.

April 7.—1 anchovy.
 April 8.—Barren.
 No. 1.—One net badly torn. 8 rockfish (S. paucispinis), 3 badly eaten by sea lice—skin only remaining; average length of 5 not destroyed, 26½ inches; average weight, 8 lbs.; 4 females, all with empty stomachs; 1 male with fish bones. 1 rockfish (S. melanops), 20 inches long, also badly eaten. 1 cutlus-cod (badly eaten), 38 inches long. 3 ground sharks (2 badly eaten), 1 with beaks of large octopus in stomach. 3 dogfish.
 No. 2.—Barren.
 No. 3.—2 rock-bass.
 No. 4.—One cod and one salmon net badly torn; 7 black-cod; 3 males and 4 females; average length, 28 inches; average weight, 8½ pounds; 3 stomachs empty; others with fish bones, young shrimps, and medusa. 3 red rockfish; bodies of 2 badly eaten; the other, 19 inches, 3 pounds; male, stom-

ach empty. 1 large flounder; 2 dogfish; 6 crabs; branch of cherry tree with anemone attached (preserved section with anemone).
 No. 5.—Cod net badly torn; 3 black-cod, all females; average length, 30½ inches; average weight, 1½ pounds; 2 stomachs empty; 1 with small piece fish bone; ova partially developed; 9 Macruri; 8 males, 1 female; average length, 24½ inches; average weight, 2½ pounds.
 No. 6.—Barren. Set from ship.
 No. 7.—1 rockfish (S. entomelas); female; 18 inches; 3 pounds; stomach empty. 8 rockfish (S. paucispinis); 1 badly eaten by sea lice and alime eels; eel found in skin; of other 7, 3 were females and 4 males; average length, 27 inches; average weight, 6½ pounds; stomachs all empty; 2 black-cod; 1 chimura; 1 barndoor skate; 5 small dogfish.
 No. 8.—Nets badly torn; 1 ground shark 10½ feet long; several dogfish; 1 flounder; 1 black-cod.

5.—Record of dip-net trials with electric light.

Date.	Time.	Position.	Length of trial.	State of sea.	Temperature.	
					Air, D. B.	Sea surface.
1897. Apr. 6	8 p. m.	Santa Catalina Island, Cal.				
9	do	Anchorage, Isthmus Cove	1 hour	Smooth	60	58
	do	do	do	do	70	58
		Monterey Bay and vicinity, Cal.				
Apr. 12	7.30 p. m. ...	Anchorage, Santa Cruz	1½ hours	Smooth	59	54
23	8 p. m.	Anchorage, Halfmoon Bay	1 hour	Light	55	49

Result of dip-net trials with electric light at surface.

April 6.—Quantity of minute crustacea, medusa, and marine refuse. One worm.
 April 9.—Several annelids. Quantity of minute crustacea and marine refuse.
 April 12.—1 small fish.

April 23.—Many young fishes, thought to be anchovies and sand lances; 4 very tiny fishes; 3 young shrimps; many minute crustacea; large crustacean like a centipede; several minute worms.

REPORT OF COMMISSIONER OF FISH AND FISHERIES. CLIX

6.—Record of trawl-line stations of the U. S. Fish Commission steamer Albatross.

Date.	Time.	Position.		Temperature.		Depth.	Character of bottom.	Wind.		Trawls set.		
		Lat. N.	Long. W.	Air.	Sur-face.			Direction.	Force.	Hours.	No.	Kind.
		<i>Santa Catalina Island, Cal.</i>				<i>Fms.</i>						
1897.												
Apr. 6	10 a. m. . .		Isthmus Cove	60	56	8-12	S. Sh. R.	NE	1-2	20	1	Cod.
6	1 p. m. . . .		Catalina Harbor . . .	62	57	7-10	S. Sh. R.	. . . do . . .	0-1	17	1	Do.
7	10.30 a. m.		East Point ent. Dakins Cove.	63	57	10-15	S. Sh. R.	Calm . . .	0	8	1	Haddock
7	4 p. m. . . .		SE. end Santa Catalina Island.	66	59	15-20	gy. S. R.	Variable	0-1	17	1	Do.
8	9.30 a. m. do	66	58	15-20	gy. S. R.	Calm . . .	0	6	1	Do.
8	3.30 p. m. do	72	59	15-20	gy. S. R.	Variable	0-1	15	1	Do.
9	5 p. m. . . .		Bird Rock, Isthmus Cove.	80	59	35-40	S. Sh. R.	SSW . . .	1	13	1	Do.
		<i>Monterey Bay and vicinity.</i>										
Apr. 12	5 p. m. . . .	2'	south, Santa Cruz Light.	64	55	8-25	S. rky.	SW	2-3	13	1	Do.
17	5.30 p. m.		Off Point Almiza.	59	55	8	S. Sh. R.	WSW . .	2	14	1	Do.

Results of trawl-line trials.

April 6, 10 a. m.—1 large stingray; 2 tiger sharks; 3 rockfish.
 April 6, 1 p. m.—Barren. Hooks fouled in kelp.
 April 7, 10.30 a. m.—2 ground sharks; 2 dogfish; 7 chimæra; 14 red rockfish of several species; 2 small sheep or fat-heads.
 April 7, 4 p. m.—8 dogfish; 1 sculpin. (Fish badly eaten by sea lice; small vial of them preserved.)
 April 8, 9.30 a. m.—Barren.
 April 8, 3.30 p. m.—2 dogfish; 3 red rockfish (badly eaten).
 April 8, 5 p. m.—3 sharks; 6 dogfish; 1 chimæra; 2 yellow-tails (badly eaten); 1 sculpin; 8 rockfish; piece branching vegetable coral.
 April 15.—Gear lost. Ground line chafed off.
 April 17.—1 rockfish; 3 large, soft starfish, with many arms; 4 small, hard starfish, short arms.

7.—Record of seine hauls.

Date.	Time.	Position.	No. of hauls.	Character of beach.	Temperature.		
					Air D. B.	Sea surface.	
		<i>Santa Catalina Island, Cal.</i>					
1897.							
Apr. 6	9.30-11.30 a. m.		Isthmus Cove	3	Sand	61	57
6	2-4 p. m.		Catalina Harbor	3	Sand and shingle . .	61	57
7	10-11.30 a. m. .		1' SE. Avalon, Dakins Cove	4	Shingle	64	58
8	3.30-5.30 p. m. .		¼ SE. Avalon, Dakins Cove	Several.	. . . do	71	60
		<i>Monterey Bay and vicinity, Cal.</i>					
Apr. 12	2-3 p. m.		Beach near steamship wharf, Santa Cruz Harbor.	4	Sand	64	56
15	8-10 a. m.		Point Almuja	2	. . . do	56	56
		<i>Neah Bay, Washington.</i>					
May 14	2.30-5 p. m. . . .		Beach between Indian Agency and Indian Village.	6	. . . do	55	49

Results of seine hauls.

April 6, both stations.—Many smelt; 6 small kelp fish; 2 small flounders; 2 whitefish; small fry like smelt; many small crabs; several shells; quantity sea lice; 1 shrimp (from Isthmus Cove).
 April 7.—Many herring; few smelt.
 April 8.—3 barrels of herring; many smelt. (Salted down 4 tubs of herring for bait.)
 April 12.—4 flounders of two species; several flounder fry; many anchovy fry; many young smelt; 1 young striped bass; 6 young cuttus-cod; 1 pipefish; several sticklebacks; several sardines; 2 small fish like billfish; many perch (feeding on small fry); 1 large and 8 small crabs; few shrimps; few shells of four species; 1 small starfish; several sand crabs; 2 small crustacea.
 April 15.—100 smelt; 1 small striped bass; 1 small crab.
 May 14.—Many large black flounders. The 8 largest averaged 13½ inches and 1½ pounds; all females, only one showing development of ova; 4 with empty stomachs, while other 4 contained fish bones and shrimps partly digested. Few small black flounders. Many starry flounders. The 4 largest averaged 13 inches and ¾ pound; 3 females (ova developed), and 1 male; stomachs all empty. Many flounder fry. Many perch, the majority with young. Many sand launces, and several young. 3 small sculpins. Several young fishes, probably cuttus-cod. Few shrimps; several small crabs.

8.—Record of hand-line stations of the U. S. Fish Commission steamer Albatross.

Serial number.	Date.	Time.	Position.		Temperature.			Depth in fathoms.	Character of bottom.	Wind.		Lines.	
			Lat. N.	Long. W.	Air.	Sur-face.	Bot-tom.			Direction.	Force.	Time used (min-utes).	No.
			o	"	o	"							
	1897.		Santa Catalina Isl- and, California.										
	Apr. 6	7 p. m.	Entrance to Isthmus Cove.		60	56		12-15	gy. s. sh. rky	S. by N.	1	15-2a	2 Meat.
	7	12.30 p. m.	1½' E. by N. of Ava- lon, Dakins Cove.		66	59		48	fne. gy. s.	ENE	0-1	17	14 Salt fish.
Hyd. 3719	7	1.5 p. m.	do.		66	59		48	do	Calm	0	14	15 Do.
Hyd. 3720	7	1.30 p. m.	1¼' E. by N. of Ava- lon, Dakins Cove.		66	59		47	do	do	0	19	14 Do.
	7	3 p. m.	Off east end Santa Catalina Island.		66	59		52	do	Variable	0-1	18	16 Do.
	7	3.40 p. m.	South of east end Santa Catalina Is- land.		66	59		44	do	do	0-1	13	14 Do.
	7	4.15 p. m.	do.		66	59		38	fne. gy. s. hk. sh.	do	0-1	19	14 Do.
	8	9.05 a. m.	Off east end Santa Catalina Island.		66	58	51.7	50	fne. gy. s.	Calm	0	29	10 Do.
	8	10.10 a. m.	do.		66	58	52.0	50	do	do	0	12	11 Do.
	8	3.30 p. m.	Rocks, east entrance Dakins Cove.		72	59		?	rky	Variable	0-1	90	? Fresh fish.
Hyd. 3721	9	9.50 a. m.	33 17 20 113 24 40		69	60		77-132	do	Calm	0	60	5 Do.
Hyd. 3721a	9	11.40 a. m.	Near preceding po- sition.		72	60		77-132	do	Variable	0-1	60	5 Do.
			Monterey Bay and vi- cinity, California.										
	Apr. 12	p. m.	Anchorage, Santa Cruz.		62	55		6	gy. s. m.	SW	2	?	? Meat.
	13	12.45 p. m.	36 44 30 121 52 00		57	55	49.0	45	do	SW. by W.	1-2	27	10 Fresh fish.
Hyd. 3722	13	4 p. m.	Anchorage, Mon- terey Harbor.		64	58		6	s. m.	W. by S.	0-2	120	? Meat.
	14	8 a. m.	do.		58	55		6	do	Calm	0	60	? Do.
	17	7 p. m.	do.		58	56		7	do	Variable	0-1	120	? Do.
	18	7 p. m.	do.		61	54		7	do	SSW	2	120	? Do.
Hyd. 3723	22	8.35 a. m.	36 56 30 122 09 00		52	51		26	gy. s.	NW	4-6	30	13 Salt fish.
Hyd. 3724	24	1.05 p. m.	37 37 30 123 02 00		60	51	49	68	gy. s. co. r.	do	2	17	12 Do.
Hyd. 3725	24	1.30 p. m.	37 41 00 123 03 00		66	51	49	45	rky	do	2	25	12 Fresh fish.
Hyd. 3726	24	2.10 p. m.	37 41 00 123 04 00		60	51	49	50	do	WNW	2	30	12 Do.
Hyd. 3727	24	4.25 p. m.	37 41 00 123 00 00		60	51	49	30-40	do	do	2	106	12 Do.

Results of hand-line trials.

April 6, 7 p. m.—2 sculpin; 1 large red rockfish. Irregular fishing from boat.
 April 7, 12.30 p. m.—Nothing.
 April 7, 1.05 p. m., Hyd. 3719.—1 dogfish.
 April 7, 1.30 p. m., Hyd. 3720.—2 dogfish.
 April 7, 3 p. m.—1 dogfish.
 April 7, 3.40 p. m.—1 dogfish.
 April 7, 4.05 p. m.—1 dogfish.
 April 8, 9.05 a. m.—Nothing.
 April 8, 10.10 a. m.—Nothing.
 April 8, 3.30 p. m.—1 red rockfish; 1 sculpin; 1 ground shark.
 April 9, 9.50 a. m., Hyd. 3721.—13 red rockfish of 3 species; 1 rockfish brought to surface and lost.
 April 9, 11.40 a. m., Hyd. 3721a.—16 rockfish (*S. pinuiger*); 9 males, 7 females; average length, 21½ inches; average weight, 6¾ pounds; stomachs all empty save one. 9 rockfish (*S. elongatus*); 1 male, 8 females; average length, 22½ inches; average weight, 3¼ pounds; stomachs all empty.
 April 12.—1 slime eel.
 April 13, 12.45 p. m., Hyd. 3722.—Nothing.
 April 13, 4 p. m.—4 large flounders of two or three species. At same time observed vast quantities of small medusæ in the water adjacent to the anchorage in Monterey Harbor; subsequently very few were seen at the same place.
 April 14.—1 large soft startfish with 20 arms; 2 small shells in its stomach.
 April 17.—1 small octopus.
 April 18.—1 small octopus.

April 22, 1.05 p. m., Hyd. 3724.—2 rockfish of different species. One 20 inches long 3¼ pounds, female, empty stomach; the other 22 inches long, 4¼ pounds, male, empty stomach.
 April 24, 1.30 p. m., Hyd. 3725.—1 rockfish (*S. flavidus*); 17 inches, 2¾ pounds, female, empty stomach. 1 rockfish (*S. miniatus*); 19 inches, 4 pounds, female, empty stomach.
 April 24, 2.10 p. m., Hyd. 3726.—1 rockfish (*S. vexillaris*); 19½ inches, 5½ pounds, female with well-developed ova, empty stomach. 2 rockfish (*S. flavidus*); 1 female, 17 inches, 3 pounds, empty stomach; 1 male, 18 inches, 3 pounds, empty stomach. 1 rockfish (*S. chlorostictus*); 15 inches, 2½ pounds, empty stomach, female with ova well developed. 1 small dogfish. 1 crinoid.
 April 24, 4.25 p. m., Hyd. 3727.—4 rockfish (*S. pinuiger*); average length, 14 inches; average weight, 1½ pounds; all females with empty stomachs. 1 rockfish with bright yellow body and black tipped fins; 14 inches, 1½ pounds, female, empty stomach. 2 rockfish like *S. maliger*; one 15 inches, 2½ pounds, female, empty stomach; the other 17 inches, 3 pounds, male, empty stomach. 7 rockfish like *S. vexillaris*; 5 males and 2 females; stomachs all empty save one, which contained portions of octopus or squid well digested; average length, 19 inches; average weight, 5 pounds. 1 rockfish (*S. paucispinis*); 20 inches, 3 pounds, female, empty stomach. 1 large flounder: 16 inches, 2 pounds, female, stomach empty. 1 halibut; 44 inches, 45 pounds, male, stomach full of small octopus or squid well digested. 1 cultus-cod; 23 inches, 4½ pounds, male, empty stomach. 1 large barndoor skate. 1 large white anemone.

9.—Record of dredging and trawling stations of the United States Fish Commission steamer *Albatross*.

Serial No.	Date.	Time.	Position.		Temperatures.			Depth.	Character of bottom.	Wind.		Instrument used.	Remarks.
			Lat. N.	Long. W.	Air.	Sur- face.	Bot- tom.			Direction.	Force.		
3634	1896. July 7	4.08 p.m.	54 51 00	167 27 00	43	43	36.3	Fathoms. 664	W. vol. S.	W. by S.	2-3	{ L. B. T. Surface L. B. T. }	} Bering Sea.
3635	July 10	1.27 p.m.	Zapadnie Bay.	St. George Island.	44	43	24	bk. S. sky	NNE	4-5		
3636	July 18	8.42 a.m.	57 05 40	170 25 00	41	38	42.2	18	rky	ENE	3-4	do	Do.
3637	July 18	9.35 a.m.	57 06 30	170 23 00	41	38	39.0	32	crs. G	NE. by E	4-5	do	Do.
3638	July 18	10.26 a.m.	57 07 30	170 28 15	41	38	38.7	33	G	do	4-5	do	Do.
3639	July 18	11.53 a.m.	57 05 45	170 30 00	41	38	38.8	27	fne. gy. S.	do	5-6	do	Do.
3640	July 18	1.38 p.m.	57 06 00	170 32 00	40	38	39.0	26	do	NE	5-6	do	Do.
<i>East.</i>													
3641	Aug. 19	2.37 p.m.	52 58 00	158 38 00	59	45	47.7	16	bk. M	SE. by E	4	do	Avatcha Bay, Kamchatka.
3642	Aug. 19	2.56 p.m.	52 57 45	158 38 30	60	47	16	do	do	4	do	Do.
3643	Aug. 20	10.49 a.m.	51 16 00	158 03 00	53	49	31.7	100	bk. S. P	S. by E	4	do	SE. coast of Kamchatka.
3644	Aug. 20	1.18 p.m.	51 09 00	157 48 00	60	51	33.1	96	bk. S.	do	2	do	Do.
3645	Aug. 31	8.34 a.m.	To westward of Robben Island, Sea of Okhotsk, from 2 to 10 miles distant. Having no chart, nearer location can not be given.	54	47	54	10	S.	SE. by S	1	do	Off Robben Island.
3646	Aug. 31	9.04 a.m.		54	47	18	18	fne. gy. S.	SE.	1	do	Do.
3647	Aug. 31	9.32 a.m.		54	47	20	20	do	do	0-1	do	Do.
3648	Aug. 31	10.05 a.m.		56	47	20	20	do	do	0-1	do	Do.
3649	Aug. 31	10.41 a.m.		57	50	25	25	fne. dk. S.	do	0-1	do	Do.
3650	Aug. 31	11.31 a.m.	57	50	28	28	bu. M. S.	ESE	1	do	Do.	
3651	Aug. 31	1.26 p.m.	53	47	20	20	fne. gy. S.	SE. by E	1	do	Do.	
3652	Sept. 6	10.00 a.m.	45 15 30	147 53 00	64	56	14	vl. C	Variable	0-1	do	Off Shana, Iturup Island.
3653	Sept. 6	10.31 a.m.	45 14 00	147 52 30	64	57	56.5	18	dk. gy. S.	do	0-1	do	Do.
3654	Sept. 19	9.01 a.m.	In Hakodate Bay	66	67	10 1/2	gn. M. S.	SW. by S	0-1	do	Hakodate Bay, Japan.
3655	Sept. 19	9.26 a.m.	do	66	67	12	do	do	0-1	do	Do.
3656	Sept. 19	9.50 a.m.	do	66	67	11 1/2	do	do	0-1	do	Do.
3657	Sept. 19	10.19 a.m.	do	67	67	13 1/2	fne. gy. S	do	0-1	do	Do.
3658	Sept. 19	10.40 a.m.	do	67	67	22	do	do	1-2	do	Do.
3659	Sept. 19	11.05 a.m.	do	68	65	15 1/2	do	do	1-2	do	Do.
3660	Sept. 19	11.27 a.m.	do	68	65	14 1/2	do	do	2-3	do	Do.
3661	Oct. 13	10.41 a.m.	Off Uki Shima, Nippon Island.	60	72	48.0	169	M. P.	NNE	5-6	do	Gulf of Tokyo, Japan.

Dredging, fishing, and collecting station, 1896.

Sta. 3634, July 7.—1 *Antimora*; 1 *Careproctus*; many *Macruri*, 5 species; 3 *Maynea*; numerous holothurians; 1 dozen sea-urchins; few red prawns; 5 quarts red crabs; 6 shells.

Sta. 3635, July 10.—2 *Hemilepidotus*; 1 *Lepidopsetta*; 2 small *Hemilepidotus*; sponges; small crustacea; sea-urchins; shells and worms abundant.

Sta. 3636, July 18.—2 bushels sand-dollars; few shells and small flounders.

Sta. 3637, July 18.—1 *Artediellus pacificus*; few sculpin; *Triglops beanii*; few broken shells, starfish, and shrimp.

Sta. 3638, July 18.—1 *Careproctus*.

Sta. 3639 and 3640, July 18.—Net empty.

Preobrajenski, Copper Island, July 30.—37 codfish, average weight 8 1/2 pounds, length 25 inches.

Nikolski, Bering Island, July 31.—40 *Pleuronectes stellatus*; numerous young salmon; 6 Dolly Varden trout; 50 sand launces; few small flounders; 1 sculpin; 2 Hexagrammos asper; 12 cod; 10 halibut.

South Rookery, Bering Island, August 1.—91 cod, average weight 8½ pounds, length 27 inches; 2 orange rockfish.

Karabelni, Copper Island, August 3.—26 cod, average weight 4½ pounds, length 21 inches.

Karabelni, August 5.—63 cod, average weight 6 pounds, length 28 inches.

Priobrajenski, Copper Island, August 7.—5 *Pleuronectes stellatus*; 3 *Lepidopsetta*; many young cod and salmon; 1 dog salmon; 15 sticklebacks from fresh-water lake.

North Rookery, Bering Island, August 7.—5 *Hemilepodotus*, 2 species; 1 orange rockfish; 13 cod.

Petropaulski Harbor, August 13.—50 humpback salmon; 30 sculpin, 4 species; 200 smelt; 150 herring; 100 blennies, 4 species; 200 tomcod; abundance of young salmon and cod; 1 young wolf-fish; 50 small flounders, 3 species; 8 *Hexagrammos asper*; few sticklebacks; 9 large crabs.

Rakoaya Bay, August 13.—2 small flounders; 1 sculpin; 1 eelpout; 10 crabs; few anemones; abundance of prawns.

Sta. 3641, August 19.—1 small flounder; 1 quart shells; ½ bushel worm-tubes (*Dentalia*); 12 hermit-crabs; 6 shrimp.

Sta. 3642, August 19.—7 flounders; 1 *Murenoides*; 12 *Lycodes*; 1 tomcod; 2 bushels worm-tubes; 6 large worms; 3 large crabs; 2 hermit-crabs; 1 ascidian; 2 quarts small clams; 5 quarts of bottom specimens of numerous small shells saved.

Sta. 3643, August 20.—2 small flounders; 4 *Agonidæ*, 2 species; 1 large red-spotted *Liparis*; 2 quarts small crabs; 2 quarts hermit-crabs; 12 anemones; few shrimp; small shells, and sponge.

Sta. 3644, August 20.—6 flounders; 4 *Podothecus*; one-half bushel shells; 6 species; 4 quarts hermit-crabs; 12 anemones, 3 species; 2 quarts small crabs; 2 naked mollusks; 3 starfish.

Sta. 3645, August 31.—2 small sculpin; few shrimp, hermit-crabs, sponge and shells.

Sta. 3646, August 31.—One large sculpin; 6 small sculpin; 2 *Agonidæ*; 6 *Limanda*; few shrimp, crabs and sponge; 6 starfish.

Sta. 3647, August 31.—1 large *Lepidopsetta*; 6 small flounders; 2 small sculpin; few shrimp and sponge; 6 starfish, 2 species.

Sta. 3648, August 31.—1 large sculpin; 1 small sculpin; 6 young cod; few shrimp and ascidians; 4 starfish.

Sta. 3649, August 31.—1 large hermit-crab; 4 small crabs; few shrimp; ascidians; hydroids; sponge; 2 small shells.

Sta. 3650, August 31.—3 small flounders; 3 young *Agonidæ*; few shrimp; hydroids; ascidians; small shells, 3 species; 1 large anemone; 1 starfish; 2 ophiurans.

Sta. 3651, August 31.—2 *Limanda*, 1 tomcod; few young cod; 1 sea-urobin; 10 small crabs. Eleven hand lines were put over at this station; caught 2 *Limanda*.

Robben Island, August 31.—8 large and 12 small *Hexagrammos asper*; 1 *Pleuronectes stellatus*. The Russians had a few Atka mackerel, which they had caught before we landed.

Shana, Iturup Island, September 4.—7 whitefish; 2 large sculpin; 12 large flounders; 20 small flounders, 2 species; 25 large blennies, several species; 12 small blennies; 6 sticklebacks; 1 large *Hexagrammos*; 20 small; half bushel smelt, 1 species; 1 dozen *Agonidæ*; few pipefish; 1 large wolf-fish.

Sta. 3652, September 6.—2 large sculpin; 1 very small sculpin; 6 young cod; 1 small eel; 2 small flounders; few isopods; sand-dollars and shrimp.

Sta. 3653, September 6.—6 *Agonidæ*; 5 small sculpin; 6 small flounders; 1 small *Liparis*; half pint shrimp, 3 species; half bushel sand-dollars.

Sta. 3654, September 19.—2 gobies; 1 holothurian.

Sta. 3655, September 19.—1 *Lepidopsetta*; 1 holothurian; few dead clam shells.

Sta. 3656, September 19.—3 flounders; 1 *Sebastes*; 1 *Agonidæ*; 6 blennies; 1 *Scopelus*; few starfish; crustaceans, half pint shells; few holothurians; ascidians and worms; 6 small squid; 50 small crabs, 6 species.

Sta. 3657, September 19.—1 flounder; 1 *Sebastes*; 1 *Tetraodon*; 2 small squid; few shells, worms, ascidians, ophiurans, and starfish.

Sta. 3658, September 19.—Few shells; 1 holothurian; 2 ascidians; 1 small squid.

Sta. 3659, September 19.—4 flounders; 1 *Sebastes*; 1 *Tetraodon*; 1 small squid; few worms; 2 large holothurians; few ascidians and shells.

Sta. 3660, September 19.—1 shell.

Hakodate Harbor, September 19.—100 small flounders, 3 species; 10 halfbeaks; 12 garfish; 100 small *Tetraodon*; 8 small mullet; 50 young *Percalabrax*; 10 *Liparis*; 1 *Seriola*; 1 large and 4 small *Hemilepodotus*; 1 *Sebastes*; 2 blennies; few shrimp; 4 crabs. Besides these there were collected from the markets 26 different species of fish.

10.—Record of animal life, drift, etc., observed at sea.

ON PASSAGE FROM SEATTLE, WASHINGTON, TO DUTCH HARBOR, UNALASKA.

Date.	Meridian positions.		Mean temperature.		Fur seals.	Whales.	Auks.	Albatrosses.	Cormorants.	Guillemots.	Gulls.	Petrels.	Puffins.	Kelp.	Remarks.
	Lat. N.	Long. W.	Air. D. R.	Sea, surf.											
1896.	° ' "	° ' "													
July 1	53 47 00	158 09 00	48	46+		Seven		Several		Few		Many	Several	Little	Several logs.
2	53 30 00	164 17 00	44	44+		Few	Several	Few	Several	Many	Many	Many	Many	Much	

FROM UNALASKA TO PRIBILOF ISLANDS VIA BOGOSLOF VOLCANO.

July 6	Dutch Harbor, Unalaska.	50	46+							Few	Few	Few	Much		
7	54 21 30	167 46 00	44	44		Many	Many	Few		Many	Many	Many	Many	Much	Off Bogoslof Volcano.
8	56 26 30	169 34 00	43	41+	Few		Many	Few	Several	Many	Many	Many	Many	Much	Few ferns.

AT THE PRIBILOF ISLANDS.

July 9 to July 18.					Many		Many	Many	Many	Many	Many	Many	Many	Much	Many seals in water near rookeries and few between St. Paul and St. George Islands.
--------------------	--	--	--	--	------	--	------	------	------	------	------	------	------	------	---

FROM ST. PAUL, PRIBILOF ISLANDS, TO DUTCH HARBOR, UNALASKA.

July 19	56 19 00	169 46 00	43	41+	Few			Few		Many	Many	Many	Many	Much	
20	54 23 30	167 03 00	49+	45+						Many	Several	Many	Many	Much	

FROM UNALASKA, ALASKA, TO COMMANDER ISLANDS, SIBERIAN COAST OF BERING SEA.

July 23	Dutch Harbor	51+	44+		3 orca	Few				Several		Few	Much	Several blackfish.	
24	54 24 15	169 08 30	45+	45	Two	Several				Many	Several	Many	Several	Much	
25	54 46 30	174 14 00	46	45						Many	Several	Many	Several	Much	Large log. Crossed 180th mer.
26	55 03 35	170 07 18	48	46+		One orca						Several	Several	Some	Several blackfish.

28	55 05 00	176 09 30	47	46				One	Few	Several	Several	Much	
29	55 02 20	No obs.	47	45+						Many	Several	Much	
30	54 45 45	168 53 30	46+	45+	Two	Many	Several	Few	Many	Many	Many	Many	Some
31	55 11 30	165 44 30	49+	47+	Two	Three	Many	Several	Two	Many	Many	Many	Much

Call at Copper Island.

AT THE COMMANDER ISLANDS.

Aug. 1 to Aug. 8, inclusive.					Few	Many	Few	Many	Many	Many	Many	Much	Small amount of driftwood. Few ducks, geese, snipe, sandpipers, and land birds.
------------------------------	--	--	--	--	-----	------	-----	------	------	------	------	------	---

FROM BERING ISLAND, COMMANDER GROUP, TO PETROPAULSKI HARBOR, KAMCHATKA PENINSULA.

Aug. 9	55 22 15	165 44 45	51	48				One	Many	Several	Many	Many	Much
10	54 42 30	162 55 00	55+	47+	Two orca				Many		Many	Many	
11	52 59 00	159 54 50	59	53	Three				Several		Many	Many	Some

One curlew.

FROM PETROPAULSKI, KAMCHATKA, PENINSULA, TO LOWER USHISHIR ISLAND, KURIL CHAIN.

Date.	Meridian positions.		Mean temperature.		Fur seals.	Whales.	Porpoises.	Auks.	Albatrosses.	Curlew.	Guillemots.	Gulls.	Petrels.	Puffins.	Kelp.	Remarks.
	Lat. N.	Long. E.	Air. D. B.	Sea, surf.												
1896. Aug. 19	51 15 30	157 53 30	54	48					One		Many	Many	Few	Many		
20	49 30 00	155 21 00	48	43+	Six	4 orca			Few	One			Several	Many		
21	48 34 11	153 52 45	45+	41				Many		Few	Many		Several	Several		
22	48 24 00	153 30 00	48	45+			Several	Few	Several	Few	Many	Several	Many	Many	Much	Many blackfish; many sea lions.
23	47 35 00	152 48 30	45+	44+				Few					Several		Much	Few cormorants; many sea lions; little driftwood.

FROM HAKODATE, YEZO ISLAND, TO YOKOHAMA HARBOR, NIPPON ISLAND, JAPAN.

Date.	Meridian positions.		Mean temperature.		Porpoises.	Albatrosses.	Gulls.	Petrels.	Flying fish.	Kelp.	Remarks.
	Lat. N.	Long. E.	Air, D. B.	Sea, surf.							
1896.			o	o							
Sept. 19	Hakodate	Bay, Japan.	63	67						Some	Few land birds; many ducks.
20	39 44 30	142 17 00	69	68						Little	
21	36 01 00	140 55 40	70+	72+		Several		Few		Some	Few snipe; few guillemots; much driftwood.
						Several			Several		

FROM YOKOHAMA, JAPAN, TO HONOLULU, HAWAIIAN ISLANDS.

Oct. 22	Off Honmoku, Gulf of Tokyo.		66	69+			Few	Few		Much	
23	34 57 00	143 25 30	68+	74+	Several	Several		One	Several		
24	34 15 30	147 47 00	67	74	Many	Many		One	One		2 whales.
25	34 04 19	152 04 00	69	73+	Many	Many		One			1 shark.
26	34 04 11	156 31 30	70+	73		Many	One	Several	Many		
27	34 25 30	160 54 46	74	71+	Few	Many		Few	Many		Carcass of shark.
28	34 26 18	165 01 25	74+	71	Many	Many		Few			1 whale.
29	34 23 46	169 32 23	74	71		Many		Few			Little Vellela; 1 tropic bird.
30	34 21 45	174 18 15	75+	71	Many	Many		Several	Few		
31	33 56 30	178 55 00	69+	69	Many	Many		Few	Few		
	West.										
31	33 09 00	177 31 00	68+	68+		Many		Several			Few tropic birds.
Nov. 1	32 28 00	174 21 15	66	68		Many		Few			Large flocks sea birds in a. m.
2	30 13 00	170 56 45	69+	70+		Many		Few	Many		Large flocks small birds in p. m.
3	28 00 47	167 41 14	74	74		Many		Few	Many		Many small birds.
4	26 29 00	164 19 00	78+	76		Several		Few	Many		One tropic bird.
5	24 54 00	160 50 00	78+	77		Several	One	Several	Many		Three man-of-war birds.
6	23 02 30	159 01 30	76+	77				Few	Many		
7	Entrance to Honolulu Harbor.		81	79				Few	Few	Many	

10.—Record of animal life, drift, etc., observed at sea—Continued.

FROM HONOLULU, HAWAIIAN ISLANDS, TO SAN FRANCISCO, CALIFORNIA.

Date.	Meridian positions.		Mean temperature.		Porpoises.	Albatrosses.	Cormorants.	Gulls.	Petrels.	Flying fish.	Kelp.	Remarks.
	Lat. N.	Long. E.	Air. D. B.	Sea. surf.								
1896.	° ' "	° ' "	°	°								
Nov. 30	21 21 00	157 28 00	80+	76	Several	Several				Many		
Dec. 1	22 58 00	154 27 30	77	76	Several	Several				Many		
2	24 33 10	151 19 15	75+	75		Many				Many		
3	26 15 00	148 20 00	74+	73+		Many				Many		
4	27 47 00	145 37 00	72	72		Many			Few	Many		One tropic bird.
5	29 17 20	143 03 25	70	69		Several			Few	Many		
6	30 26 00	140 09 00	68+	68		Many			Few			Considerable Veella.
7	31 36 30	137 02 00	67+	66		Many			Few			Do.
8	32 53 00	133 32 00	66+	65		Many			Few			Do.
9	34 01 25	130 00 12	67+	64	Few	Several						
10	35 55 45	126 17 30	60+	57+		Several		Many	Few		Some	One diver, several guillemots, one shark, one whale, much driftwood.
11	Off Sausalito, California.		57+	53								

FROM SAUSALITO, SAN FRANCISCO BAY, TO SAN DIEGO BAY, CALIFORNIA.

Dec. 30	37 18 45	122 32 00	58	54		Several	Several	Many	Many		Some	Few guillemots.
31	35 03 00	121 11 00	62+	57		Few	Several	Many	Many		Some	
1897.												
Jan. 1	33 02 00	117 45 00	61	58+			Many	Many	Several		Much	Anchor in San Diego Bay.

OBSERVATIONS ON THE MULLET AND OYSTERS OF HAWAII.

The principal food of the native Hawaiians, like the Japanese, is fish, the waters around the islands containing many varieties, some in great numbers. The market in Honolulu is a large, substantial structure, paved, open on the sides, clean, and well kept. The sale of fish is under Government supervision, an inspector having charge of all fish delivered, which if not sold after they have been taken from the water a certain length of time are converted into fertilizer.

The Chinese largely conduct this industry, not only in the open waters, but in the private ponds, and their methods are similar to those in their native country. A few natives also are employed in fishing.

The mullet is the principal marketable fish, and those supplied are largely taken along the reefs; but another source of this species is from the ponds, and this affords the main supply during inclement weather.

The fish-ponds are nearly as old as the peopling of the islands, for even the traditions give no time when they were first built; but it is supposed by the best authorities that they date back at least 500 or 600 years, and before the advent of civilization were the source of meat supply in addition to the sea fishes, as these islands when discovered contained no mammals. Fish and poi (fermented paste from the root of the taro) were the diet of the ancient Hawaiians, and are very dear to the modern natives, as fish and rice are to the Japanese. These fish-ponds were very numerous on all the islands, but through disuse and neglect many have become silted up and are now marshes, while the walls have been destroyed in others by the progress of civilization and the ravages of nature and are now dry land. Still quite a number are in excellent condition and are used for raising mullet from the small fry. There are about a dozen of these ponds in the vicinity of Honolulu, ranging in size from 15 or 20 acres to 150 acres.

The site selected for the pond usually is in shallow water, where the configuration of the land is such as to reduce as much as possible the length of the wall to be built, and in localities visited by the spawning mullet. The Loko Hanaloa, on the Pearl Lochs, covers at least 150 acres, but the wall necessary to inclose this area is less than one-fourth of a mile in length. The walls are constructed of volcanic or coral rock and originally without gratings. Interstices in the wall formed by the loose rock allowed the tidal flow. Prior to the advent of the missionaries, when the government of the island was in the hands of the native chiefs and subchiefs, every native was obliged to contribute his labor for several days, at certain definite periods, to his chief, and tradition states that in building the walls lines of men were formed from the sea to the hillsides and the rock passed from hand to hand.

There is no artificial hatching of food-fishes on any of the Hawaiian Islands, nor has there ever been any, so far as could be learned, but the fry are driven or transported to these artificial ponds and there raised. When the mullet come into the shoaler waters to spawn, the young fry seek, instinctively, the protection of the shallowest water. In former

times the natives from their lookouts would discover the location of the schools of fry, and then in their canoes, or by wading, would drive the fry toward the pond walls, where they would escape through the interstices into the ponds. In this manner the ponds were stocked. It is probable that many again found their way to the sea, but a large part, no doubt, learned the protection the walls afforded against predatory fishes, and remained to grow up and fatten. At the present time the walls are filled up solid, but openings or gratings, protected by grated gates to prevent the entrance of the larger fishes, are left at intervals for the ingress and egress of the tide waters. In stocking the ponds the fry are caught in small nets of mosquito netting or other open woven fabric, placed in pails and tubs, and quickly transported to the ponds; some few are driven through the gratings with the entering tide. The mullet are the only fish intentionally introduced, but naturally by the methods employed a few other species enter, which generally are destructive to the young mullet, and are removed whenever it is possible to do so.

Pond mullet are considered the finest, and when sea mullet bring 10 cents a pound those from the ponds find ready purchasers at 13 cents. The pond mullet is the fish usually eaten raw by the natives; from 6,000 to 10,000 of them are marketed in Honolulu each week, besides those taken at sea.

OYSTERS.

That the oyster was a native of these waters and occurred in great numbers is evidenced by the numerous oyster-banks found in different localities now raised above the sea level and having an earthy covering. When visiting the fish-ponds on the Pearl Lochs, I examined the ancient oyster-banks on the eastern side of the middle loch, on the neck which joins Waipu with the mainland. The shore line here consists of a vertical bluff from 10 to 15 feet high, with a stratum of oyster shells 6 to 8 feet thick. This stratum is exposed on the loch face for at least half a mile, and it can be traced for a long distance across the peninsula. From specimens procured it seems that they closely resemble our own oyster of the Atlantic coast. These are not shell heaps, like those on our Southern coast and in other localities, but are entire, *in situ*, as both valves are usually in place and can be readily removed. They do not seem to occur in masses or clusters, but are large single oysters, in size resembling the better varieties of the marketable Chesapeake Bay oysters. It is possible that these oyster-banks were formed layer by layer, the upper ones smothering the lower, until through some natural cause the beds were covered with mud and afterwards lifted above the sea level. On this little peninsula, in two different places, I examined the remains of large numbers of the pearl oysters, which seem to have occurred in pockets among the other oysters. It is said that at present a few pearl oysters are found off Beckoning Point.

Upon invitation of Hon. John F. Colburn I visited his fish and oyster pond on Pearl Lochs. In reply to an inquiry requesting information

relating to his efforts in oyster-culture in Hawaii, Mr. Colburn wrote as follows:

In the month of October, 1893, I imported from Mr. M. B. Moraghan, of San Francisco, three cases of oysters for the purpose of planting. Two of the cases contained about 1,000 eastern transplanted, and one case contained about 3,000 of the native California. They were brought down on the steamship *Australia*, in the ice-house, and arrived in apparently good order. I at once had them removed to my pond at Manana Ewa, and planted in a depth ranging from 1 foot to 2 feet of water.

Some three months after I made a thorough search of different places where I had planted oysters, and found that the native California were all dead, and of the eastern transplanted about 50 per cent were still living, though considerably sunk into the soft mud at the bottom of the pond. I had these taken up and put down again, and some three months afterward I examined them again and found they had started to grow; the new shell forming was easily noticeable. I continued my practice of taking them up at different intervals of time until the early part of 1895, when I was so elated with the prospect of my success that I made arrangements with Mr. Moraghan to send me down more eastern transplanted, with two objects in view: (1) To have fresh eastern oysters to supply the oyster-eaters of our city, and (2) to have them answer for the purpose of seed for propagating.

I imported 38,614 from San Francisco by the steamship *Australia*, having them come in five different trips of the vessel. About two-thirds were brought down on the open deck in boxes, and were wet down every morning when decks were being washed down. The balance came in the ice-house. With the former way my loss was more in number, but the latter way was the most expensive. On deck I could get the oysters landed for about \$10 a ton measurement, but through the ice-house the charges were 5 cents a pound for freight.

As fast as the oysters would arrive I would have them sent down to my pond and laid out. In a month or so afterwards they would get very thin and be unfit for the market. However, I allowed them to recuperate by getting acclimated to the conditions of my pond as well as to the food.

In the latter part of 1895 I discovered young oysters clinging to stones and dead oyster shells. I have watched them very carefully and at different intervals of this year I have found more young ones. Of course the young are not as many as I would like to see, still I trust that in time I will be able to boast of a bed of Hawaiian oysters reared from the seed of the American eastern oyster. From those I have imported I am in a position to furnish to those desiring oysters a mess of them fresh from the water. The last lot have been now about eighteen months in my pond and are in fine and fat condition, having grown twice their original size.

Fresh sea water empties into my fish-pond through gates and a large spring of fresh water also runs into it, thereby making the water a little brackish.

It will be seen that oyster-culture in Hawaii is of very modern date and in an experimental stage. There is scarcely any doubt that the waters are suitable for oyster-culture; the ancient beds and the experience of Mr. Colburn attest it, but further investigation is necessary to discover the proper conditions for a commercial enterprise.

I went over the oyster-beds with Mr. Colburn and we took from the water both transplanted oysters and those that had been propagated in the pond. When taken from the water they have a brownish appearance, which upon inspection proves to be a mossy growth on the shell. They are large, well rounded, and when opened beautiful in appearance and of good flavor. They are planted in a fish-pond which is stocked with mullet. The bottom is soft, and I believe covered with grass. The gratings for tidal access are very small.

A MANUAL OF FISH-CULTURE,
BASED ON THE
METHODS OF THE UNITED STATES COMMISSION OF FISH AND FISHERIES.

PREPARED UNDER THE DIRECTION OF
JOHN J. BRICE,
UNITED STATES COMMISSIONER OF FISH AND FISHERIES.

TABLE OF CONTENTS.

	Page.
Introduction.....	5-6
The Salmon of the Pacific Coast.....	7-26
The Atlantic and Landlocked Salmon.....	27-70
The Rainbow Trout.....	71-89
The Brook Trout.....	91-101
The Lake Trout.....	103-117
The Whitefish.....	119-131
The Shad.....	133-158
The Black Basses, Crappies, and Rock Bass.....	159-177
Miscellaneous Fresh-Water Fishes.....	179-191
Minor Trouts and the Grayling.....	179
Lake Herring and other Whitefishes.....	180
Muskellunge.....	181
Yellow Perch.....	182
Striped Bass and White Perch.....	185
Alewives or River Herrings.....	186
Smelt.....	188
Golden Ide.....	188
Sturgeons.....	189
The Cod.....	193-207
The Common Mackerel.....	209-213
The Flatfish or Winter Flounder.....	215-218
Miscellaneous Salt-Water Fishes.....	219-227
Tautog.....	219
Spanish Mackerel.....	220
Haddock, Pollock, and other Gadidae.....	222
Cunner.....	223
Scup.....	223
Séa Bass.....	223
Squeteagues.....	224
Sheepshead.....	224
Sea Herring.....	225
Sand-dab and Four-spotted Flounder.....	227
The American Lobster.....	229-238
The Transportation of Fish and Fish Eggs.....	239-244
Spawning Seasons of Fishes Propagated, Character of Fish Eggs, Period of Incubation, etc.....	245-247
Notes on the Edible Frogs of the United States and their Artificial Propagation.....	249-261
Oysters and Methods of Oyster-Culture.....	263-338
Notes on Clam-Culture.....	339-340

LIST OF ILLUSTRATIONS.

Plate number.	To face page
1. Clackamas (Oregon) Salmon Station.....	5
2. Figure of a Fish, showing the parts usually referred to in Descriptions.....	6
3. <i>Oncorhynchus tshawytscha</i> . Quinnet Salmon; Chinook Salmon; King Salmon.....	7
4. <i>Oncorhynchus nerka</i> . Blueback Salmon; Redfish.....	11
5. <i>Oncorhynchus kisutch</i> . Dog Salmon.....	13
6. <i>Salmo gairdneri</i> . Steelhead.....	13
7. Rack for stopping ascent of Salmon at Battle Creek, California.....	15
8. Engine-house and Hatchery at Baird; Current-wheel and Piers for holding Rack.....	19
9. Current-wheel for pumping water at Baird, California.....	21
10. Interior of Hatchery at Battle Creek, showing Salmon-basket.....	23
11. Pens for holding ripe Fish, and Stripping Platform at Battle Creek, California.....	25
12. <i>Salmo salar</i> . Atlantic Salmon.....	27
13. Views of Dead Brook inclosure for Salmon.....	31
14. Salmon Live-car used in transporting Fish. Live-cars on route with Fish.....	33
15. Salmon Rearing-troughs, Craig Brook Station, Maine.....	43
16. Examining Fish for stripping. Stripping Female Salmon.....	45
17. Packing Salmon Eggs. Picking out dead Eggs. Handling Egg-trays.....	51
18. Fungus on Salmon Egg. Fungus on Salmon Egg, bearing Reproductive Organs. Reproductive Organs of Egg Fungus.....	63
19. Taking Spawn of Landlocked Salmon at Grand Lake Stream, Maine.....	67
20. <i>Salmo irideus</i> . Rainbow Trout.....	71
21. View of Wytheville Station, showing Breeding Ponds, with Hatchery in the background.....	73
22. Spawning Pond.....	74
23. Interior view of Wytheville Hatchery, showing men picking out dead Eggs.....	77
24. Trout Rearing-ponds at Wytheville Station.....	79
25. Rearing-pond.....	81
26. <i>Salvelinus fontinalis</i> . The Brook Trout.....	91
27. Trout Ponds, Northville, Michigan.....	93
28. Selecting and stripping ripe Trout, Northville, Michigan.....	95
29. Interior view of Northville Hatchery.....	97
30. Removing green Eggs from Shipping-trays. Packing eyed eggs, Northville.....	101
31. <i>Cristivomer namaycush</i> . Lake Trout.....	103
32. Collecting lake-trout spawn on fishing steamer in Lake Michigan.....	105
33. <i>Coregonus clupeiformis</i> . Common Whitefish.....	119
34. Stripping a Whitefish.....	122
35. View of Battery for hatching Whitefish.....	127
36. <i>Alosa sapidissima</i> . Common Shad.....	131
37, 38, and 39. Plates showing the development of young Shad.....	136
40. Main deck of steamer <i>Fish Hawk</i> , equipped for hatching Shad.....	143
41. Interior of Hatchery at Battery Station, equipped with hatching-jars.....	151
42. Battery Station Hatchery. Fish Commission car loading fish at Neosho.....	158
43. <i>Micropterus salmoides</i> . Large-mouth Black Bass.....	159
44. <i>Micropterus dolomieu</i> . Small-mouth Black Bass.....	159
45. <i>Pomoxis annularis</i> . Crappie.....	163
46. <i>Pomoxis sparoides</i> . Calico Bass; Strawberry Bass.....	163
47. <i>Ambloplites rupestris</i> . Rock Bass.....	163
48. Bass and Trout Ponds at Neosho, Missouri.....	167
49. Bass Ponds at San Marcos, Texas.....	173
50. <i>Salmo mykiss</i> . Black-spotted Trout.....	179
51. <i>Argyrosomus arctedi</i> . Lake Herring; Cisco.....	181
52. <i>Gadus callarias</i> . Cod.....	193
53. Stripping Cod on Vessel.....	196
54. Gloucester Station.....	198
55. Pool for retaining Brood Fish at Woods Hole.....	200
56. McDonald Tidal-boxes, used for hatching Cod and Flatfish.....	202
57. Chester boxes.....	204
58. <i>Scomber scombrus</i> . Common Mackerel.....	209
59. <i>Pseudopleuronectes americanus</i> . Flatfish or Winter Flounder.....	215
60. <i>Tautoga onitis</i> . Tautog.....	219
61. <i>Homarus americanus</i> . The American Lobster.....	220
62. Interior of Transportation Car.....	239

Plate number.	To face page
I. Anatomy of the Oyster	276
II. Salinometer and Salinometer Cup.....	282
III. Ground-plan and section of Ponds for Spat-culture	323
IV. Details of Filter for Ponds used for Oyster-culture.....	330
V. Inner and Outer Faces of Shell of Typical American Oyster.....	340
VI. Views of Valves of Pacific Oyster.....	340
VII. Development of Oyster	340
VIII. Views of Oyster Embryos	340
IX. Set of Oysters on Shell, showing crowding.....	340
X. Oyster Spat, 2 or 3 weeks old, on inside of Oyster Shell.....	340
XI. Oyster Spat about 2 months old, on a Stone.....	340
XII. Oysters, 1, 2, and 3 years old.....	340
XIII. Oysters 4 and 5 years old.....	340
XIV. 1, Photo-micrograph of Diatom. 2, Food of South Carolina Oyster	340
XV. 1, <i>Urosalpinx cinerea</i> . 2, <i>Mytilus edulis</i> . 3, <i>Sabellaria vulgaris</i> . 4, <i>Fulgur carica</i>	340
XVI. Starfish attacking Oysters	340
XVII. Bunch of Oysters, showing Growth of Mussels and Barnacles	340
XVIII. 1, <i>Orepidula formicata</i> . 2, <i>Orepidula plana</i> . 3, <i>Orepidula convexa</i> . 4 and 5, <i>Anomia glabra</i> . 6, <i>Pecten irradians</i> . 7, Oyster attached to pebble.....	340

FIGURES IN TEXT.

	Page.		Page.
Gravel Filter	41	Plan of Neosho Station, showing shape and depth of ponds, with location of Hatchery and Superintendent's Dwelling	166
Wire Filter	42	Artificial Nest for rearing Black Bass (perspective and sectional views)	171
Trough arranged for Eggs	49	Ovary of Yellow-perch with nearly ripe Eggs	183
Longitudinal section of case of Atlantic Salmon Eggs.....	52	Part of a recently hatched mass of Yellow-perch Eggs.....	183
Atlantic Salmon recently hatched.....	54	Diagram of Tidal Cod Hatching-box.....	202
Troughs arranged for rearing.....	55	Spring Frog or Leopard Frog (<i>Rana vire-scens</i>)	255
Stand of troughs for rearing Atlantic Salmon.....	56	Green or Spring Frog (<i>Rana clamata</i>)	256
Hatching-troughs, Guard-screen, etc.....	78	Figures illustrating relative size of the Tympanum in the two Sexes.....	257
Cross-section through box after it has been packed and closed	84	Common Bullfrog (<i>Rana catesbiana</i>)	258
Egg-tray	84	Western Frog (<i>Rana pretiosa</i>).....	259
Foundation-board	84	Western Bullfrog (<i>Rana aurora</i>).....	259
Ice-hopper	85	Anatomical figure of the Oyster	278
Egg-trays packed and cleated	85	Tangle and Tackle	317
Outside case.....	86	Drill-dredge in position for work.....	316
Floating box	107	Drill-dredge open for emptying	317
Clark-Williamson trough	110	Receptacle for Cultch	324*
Pans used in cleaning Eggs.....	148		
Shad-hatching Table	149		
Automatic Shad-hatching Jar.....	150		
Application of a Measuring Scale to a Jar of Shad Eggs.....	154		



CLACKAMAS, OREGON, SALMON STATION.

A MANUAL OF FISH-CULTURE, BASED ON THE METHODS OF THE UNITED STATES COMMISSION OF FISH AND FISHERIES.

INTRODUCTION.

The work of the United States Commission of Fish and Fisheries is carried on at twenty-five stations or hatcheries located at suitable places throughout the country. At Woods Hole and Gloucester, Massachusetts, cod, mackerel, lobster, and other important marine species are propagated and the fry are deposited on the natural spawning-grounds along the coast. At Battle Creek, Baird, and Hoopa Valley in California, at Clackamas in Oregon, and Little White Salmon River in Washington, the eggs of the Pacific salmon are collected and hatched, and the fry are planted on the spawning-beds in the neighboring streams. The Atlantic and landlocked salmons are cultivated in Maine at Craig Brook and Green Lake to restock the depleted streams and lakes of New England and northern New York. On the Great Lakes at Cape Vincent, New York; Put-in Bay, Ohio; Alpena, Michigan, and Duluth, Minnesota, the work is with whitefish and lake trout, in order to sustain the great commercial fisheries conducted for those species. Hatcheries in the interior at St. Johnsbury, Vermont; Wytheville, Virginia; Northville, Michigan; Manchester, Iowa; Bozeman, Montana; Neosho, Missouri; Quincy, Illinois; San Marcos, Texas, and Leadville, Colorado, are devoted to the important work of maintaining in the inland lakes and streams the supply of brook trout, rainbow trout, black bass, crappie, and other fishes. During the spring, on the Potomac, Delaware, and Susquehanna rivers, shad are hatched and are distributed in suitable streams along the Atlantic Coast.

For the distribution of fish and eggs the Commission has four cars specially equipped with tanks, air-circulating apparatus, and other appliances.

In the prosecution of marine work three vessels are used, the steamers *Albatross* and *Fish Hawk*, and a schooner, the *Grampus*. The *Albatross* is fitted with appliances for deep-sea dredging and collecting work, and is used for surveying and exploring ocean bottoms and investigating marine life. The *Fish Hawk* is in reality a floating hatchery, and is engaged in hatching shad, lobsters, and mackerel, in collecting eggs, and in distributing fry, besides making topographic surveys of fishing-grounds, etc.

The necessity for a handbook describing the manner of propagating the different fishes reared by the United States Commission of Fish and Fisheries has long been felt in the Commission, and it is thought

that such a manual will be of value to all persons interested in fish-culture. The material for the present work has been furnished by experienced fish-culturists connected with the Commission, who have treated of the subjects with which they were especially familiar. Owing to the interest shown in the cultivation of oysters and frogs, special reports on these subjects have also been incorporated.

The following is a list of the contributors and their subjects:

- Charles G. Atkins, Superintendent U. S. F. C. Station, Craig Brook, Maine.
The Atlantic and Landlocked Salmon.
- F. M. Chamberlain, Assistant, U. S. Fish Commission, Washington, D. C.
Edible Frogs and their Artificial Propagation.
- Frank N. Clark, Superintendent U. S. F. C. Stations in Michigan.
The Brook Trout and the Lake Trout.
- J. Frank Ellis, Superintendent of Car Service, U. S. F. C., Washington, D. C.
Transportation of Fish and Fish Eggs.
- H. F. Moore, Assistant, U. S. Fish Commission, Washington, D. C.
Oysters and Methods of Oyster-Culture.
- William F. Page, Superintendent U. S. F. C. Station, Neosho, Mo.
The Black Basses, Crappies, and Rock Bass.
- George A. Seagle, Superintendent U. S. F. C. Station, Wytheville, Va.
The Rainbow Trout.
- Livingston Stone, Superintendent U. S. F. C. Station, Baird, Cal.
The Salmon of the Pacific Coast.
- J. J. Stranahan, Superintendent U. S. F. C. Station, Put-in Bay, Ohio.
The Whitefish.
- Stephen G. Worth, Superintendent U. S. F. C. Station, Washington, D. C.
The Shad.

The chapters on the lobster and most of the minor fishes were furnished by Dr. Hugh M. Smith.

Valuable information on marine fishes was also furnished by Lieut. Franklin Swift, U. S. N., C. G. Corliss, E. E. Hahn, Alexander Jones, and E. F. Locke, of the United States Fish Commission, and on the quinnat salmon by J. P. Babcock, of the California State Fish Commission.

In order to increase the usefulness of the work to the general reader, a technical description of each important fish is given, together with brief information regarding its geographical distribution, habits, movements, size, growth, food, natural spawning, etc.

While the operations described are essentially those of this Commission, they are usually the same as those employed by the State commissions and individual fish-culturists, although, in some instances, excellent work is done by other methods. The propagation of the various marine species is carried on only at the Government hatcheries. The methods described for hatching *Salmonidæ*, while differing in minor particulars, are practically interchangeable, and may be used at the discretion of the fish-culturist.

JOHN J. BRICE,
Commissioner.

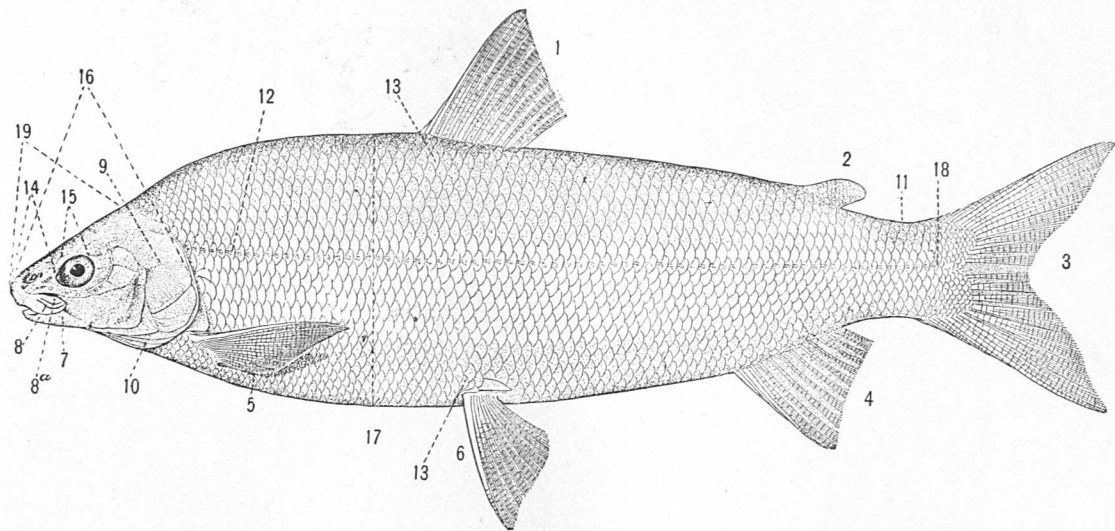
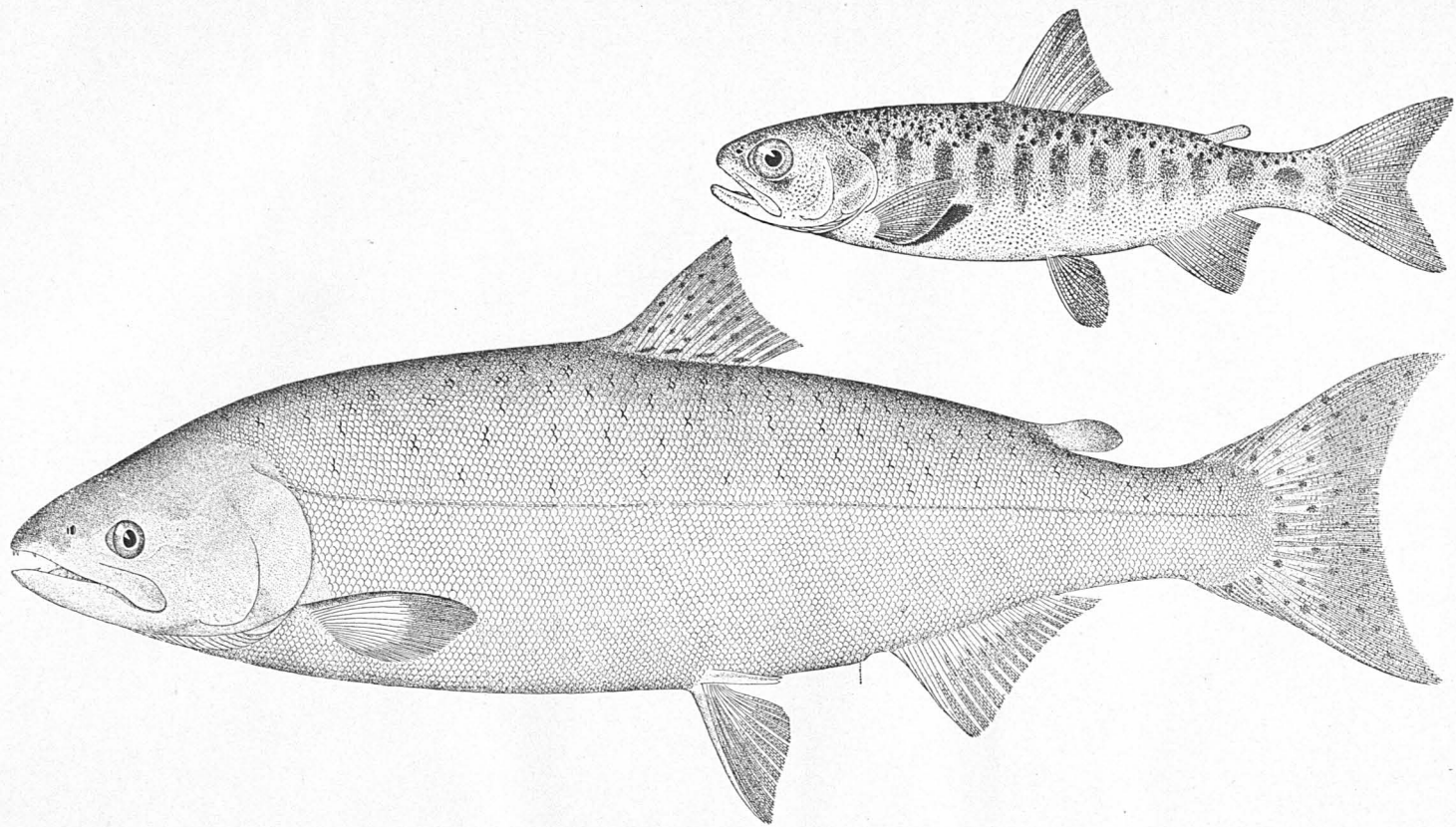

FIGURE OF A FISH SHOWING THE LOCATION OF PARTS USUALLY REFERRED TO IN DESCRIPTIONS.

- | | | |
|-----------------------------|---|---|
| 1. Dorsal fin. | 8a. Supplemental maxillary. | 14. Snout. |
| 2. Adipose fin. | 9. Opercle. | 15. Eye. |
| 3. Caudal fin. | 10. Branchiostegals. | 16. Head. |
| 4. Anal fin. | 11. Caudal peduncle. | 17. Depth. |
| 5. Pectoral fin. | 12. Lateral line. | 18. Base of caudal. |
| 6. Ventral fin. | 13. Series of crosswise scales usually counted. | 19. Distance from snout to nape or occiput. |
| 7. Lower jaw, or mandible. | | |
| 8. Upper jaw, or maxillary. | | |



ONCORHYNCHUS TSCHAWYTSCHA. *Quinnat Salmon; Chinook Salmon; King Salmon.*

The upper figure is drawn from a young example, 4 inches long.

THE SALMONS OF THE PACIFIC COAST.

There are five species of salmon on the Pacific coast which belong to the genus *Oncorhynchus*, namely, the chinook or quinnat salmon (*Oncorhynchus tshawytscha*), the red or blueback salmon (*Oncorhynchus nerka*), the humpback salmon (*Oncorhynchus gorbusha*), the silver salmon (*Oncorhynchus kisutch*), and the dog salmon (*Oncorhynchus keta*). The features which separate the Pacific salmon from the Atlantic salmon are not marked and consist chiefly in a larger number of rays in the anal fin, and more branchiostegals, gillrakers, and pyloric cæca.

The characters noted in the following key will usually be sufficient to distinguish the different species of Pacific salmon:

Quinnat salmon: Scales in longitudinal series from 135 to 155, averaging about 145; pyloric cæca 140 to 185; gillrakers comparatively short and usually 23 in number, 9 being above the angle; rays in anal fin 16; branchiostegals 15 to 19. Body robust; head conic; eye small; caudal fin deeply forked. Color above dusky, sometimes with bluish or greenish tinge; sides and belly silvery; head dark, with metallic luster; back and the dorsal and caudal fins with numerous round black spots.

Blueback salmon: Scales in longitudinal series about 130; pyloric cæca, 75 to 95; gillrakers comparatively long and 32 to 40 in number; rays in anal fin 14 to 16; branchiostegals 13 to 15. Body rather slender; caudal fin much forked; anal and dorsal fins low. Color, above bright blue, sides silvery, no spots.

Humpback salmon: Scales very small, 210 to 240 in longitudinal series; pyloric cæca very slender, about 180 in number; gillrakers short, about 28, 13 being above angle; anal rays 15; branchiostegals 11 or 12. Color, bluish above, silvery on sides; hind part of back, adipose fin, and tail with numerous black spots, largest and of oblong form on tail.

Silver salmon: Scales large, 125 to 135 in longitudinal series; pyloric cæca comparatively few and large, 45 to 80 in number; gillrakers long and slender, 23 in number, 13 below angle; anal rays 13 or 14; branchiostegals 13 or 14. Body long; head short, conic; snout blunt; eye small; fins small, caudal deeply forked. Color bluish-green, sides silvery, finely punctulated; spots few and obscure on head, back, dorsal, adipose dorsal, and upper rays of caudal.

Dog salmon: Scales of medium size, 138 to 155 in lateral line; pyloric cæca 140 to 185; gillrakers short and few, 9 above and 15 below angle; 13 or 14 rays in anal fin; branchiostegals 13 or 14. Form of quinnat, but head longer and more depressed. Dusky above and on head, paler on sides; very fine spots on back and sides, often wanting; tail plain dusky or finely spotted, with black edge; other fins blackish.

These salmons are the most important group of fishes entering the rivers of North America. The steelhead (*Salmo gairdneri*), technically a trout, but popularly regarded as a salmon, also inhabits the waters of the Pacific coast and adds to the importance of the salmon tribe.

In recent years the average annual catch of salmon in the Pacific States and Alaska has been about 100,000,000 pounds, with a first value of about \$2,800,000; as placed on the market, in a fresh, salted, or canned condition, the value is about \$5,700,000. The yearly catch of about 25,000,000 pounds of salmon in British Columbia, having a value, when prepared, of \$2,500,000, raises the approximate annual value of the Pacific salmons to \$8,200,000.

THE QUINNAT SALMON.

The quinnat salmon (*Oncorhynchus tshawytscha*) is known by a number of other common names in various parts of its range; among them are chinook salmon, king salmon, Columbia salmon, Sacramento salmon, tyee salmon, and saw-qui. The quinnat is the most important of the salmons. It is not only superior in food qualities, but attains a vastly larger size, has a wider geographical range, and has greater commercial value than all the others. When fresh from the ocean it is a very handsome, resplendent, well-formed fish, greatly resembling the Atlantic salmon (*Salmo salar*), although its form is less symmetrical and its outlines less graceful. The flesh is of a uniform rich red color, becoming paler or streaked at the approach of the spawning season. The great value of the fish for canning purposes is largely due to the persistence of the red color of the meat after cooking.

In size no other salmon in the world compares with it. In the Yukon River, Alaska, it reaches a weight of over 100 pounds, and in the Columbia River there are well-authenticated cases of its weighing more than 80 pounds. Farther south it runs smaller, although in the Sacramento individuals weighing 50 or 60 pounds are not rare; 22 pounds is a fair average weight in the Columbia River, and 16 pounds in the Sacramento.

The known range of the quinnat salmon is practically from Monterey Bay (latitude 36½) to Yukon River, although individuals have been seen in Norton Sound, somewhat north of the Yukon, and as far down the coast of California as Ventura River. Since it thrives well in very cold water it is likely that its range extends to and possibly within the Arctic Ocean.

While in the sea quinnat salmon probably do not wander very far from the mouths of the rivers they have left, and for this reason usually return to spawn in those rivers in which they were hatched. They prefer the larger rivers, like the Sacramento, the Columbia, the Nushagak, and the Yukon. They are very persistent in ascending the rivers to spawn; the first fish take up the first available spawning-sites and force the newcomers farther up stream, until finally the highest points are reached. They have been seen crowding up the rivulets which form

the headwaters of the Sacramento until nearly half their bodies were exposed to the air. No matter how far the headwaters of a river are from the ocean, some of the salmon will press forward until stopped by impassable obstructions or water too shallow for them to swim in. On reaching the headwaters they remain for a week or two before proceeding to the spawning-grounds. Their rate of progress varies with the season, and probably depends to a great extent on the rainfall and the state of the river, rain, roily water, and high water always hastening their progress.

When they first come from the ocean the sexes are almost identical in appearance, but as the time for spawning approaches a difference is noticed between the males and the females, which during the spawning season becomes more marked. The fully developed ova of the female give her a round, plump appearance, while the male grows very thin; his head flattens, the upper jaw curves like a hook over the lower, the eyes become sunken; large, powerful, white, dog-like teeth appear on both jaws, and the fish acquires a gaunt and savage appearance. As soon as they reach fresh water their appetites grow less, their throats begin to narrow, and their stomachs to shrink. This does not at first entirely prevent them from feeding, but it changes them enough to enable them to overcome the temptation to return to their well-stocked feeding-grounds in the ocean, and the longer they remain in fresh water the greater are the changes, and the desire to turn back for food is correspondingly lessened. This change comes about gradually, increasing day by day from the time they leave tide water until at the near approach of the spawning season their throats and stomachs become entirely incapacitated for receiving food, and the desire and ability to feed leave them entirely. The great reserve of flesh and blood which they bring with them from the ocean enables them to keep the vital organs active until their mission up the fresh-water streams is accomplished.

Quinnat salmon that spawn a long distance from the ocean do not return to it again, but die on or near their spawning-grounds. This singular fact has been disputed, but its truth has been proved repeatedly and conclusively. After spawning they rapidly deteriorate, the flesh shades off to a light, dirty pink and they become foul, diseased, and very much emaciated through wounds and great exertion. Their scales are wholly absorbed in the skin, which is of a dark olive or black hue, and blotches of fungus appear on their heads and bodies, and in various places are long white patches where the skin is partly worn off. Their fins and tails become badly mutilated, and in a short time they die exhausted.

The quinnat salmon first appear on the Pacific coast at Monterey Bay, where many are caught with hook and line as early as the second week in January, and are next seen in the Sacramento River in numbers in February. In the Columbia River they appear in March, but are not abundant until April or May. They arrive in southern Alaska in May and farther north in June, while it is probable that it is still later

before they ascend the Yukon, where the running season is very short and may not exceed a month or six weeks. The early runs in the Columbia River are usually from one to three weeks passing from the mouth of the river to Clifton, about 20 miles. They first appear at The Dalles, 200 miles up the river, in the middle of April, and are found in great quantities at this point about the middle of June, two months after they appeared in large numbers at the bar. This would indicate that they proceed up the Columbia at the rate of 100 miles a month. In the later runs they probably travel faster.

The spawning season of the quinnat salmon varies in different rivers, and, considering the entire coast, extends over a period of fully six months. In July the summer run is spawning at the headwaters of the McCloud and Sacramento; in August and September, farther down these rivers. In October the fall run has begun at the McCloud and below, and this run continues spawning through November into December. In the Columbia the spawning season begins at the headwaters in June; at Clackamas, 125 miles from the mouth of the river, it begins about the middle of September and continues until November.

A few days before they are ready to spawn the salmon hollow out elongated cavities with their heads and tails in the gravel beds of the river where there is some current, and here in due time the eggs and milt are deposited. The eggs drift into the crevices in the pile of stones thrown up below the hollow, sink to the bottom, and remain in that protected position during incubation; here, also, the young remain until the umbilical sac is absorbed. The eggs and young are liable to destruction by freshets, but are comparatively safe from other injurious influences.

The quinnat salmon is not so prolific as the Atlantic salmon, 300 or 400 eggs to each pound weight of the parent fish being about a fair average.

In view of the enormous annual destruction of this salmon for commercial purposes the necessity for its propagation became manifest at an early period in the history of the Pacific fisheries. Fortunately the species is readily susceptible of artificial propagation on a large scale. In 1873 the application of fish-cultural methods to this species began on the McCloud River, California. The propagation work, since grown to large proportions, now engages the attention of all the coast States as well as the general government, and in 1896 was more extensive than ever before. Whenever large numbers of the fry, artificially hatched, have been placed in the waters of the Pacific coast, whether in the tributaries of the Sacramento or the Columbia, an increase in the run of full-grown fish has been observed after the time required for a salmon to mature (about four years) has elapsed.

As the salmon ascend the rivers they are caught by gill nets, pounds, weirs, fyke nets, seines, wheels, and other devices, but the great bulk of those taken in the Columbia and Sacramento are caught with gill nets drifting with the current or tide as they head up stream. In the

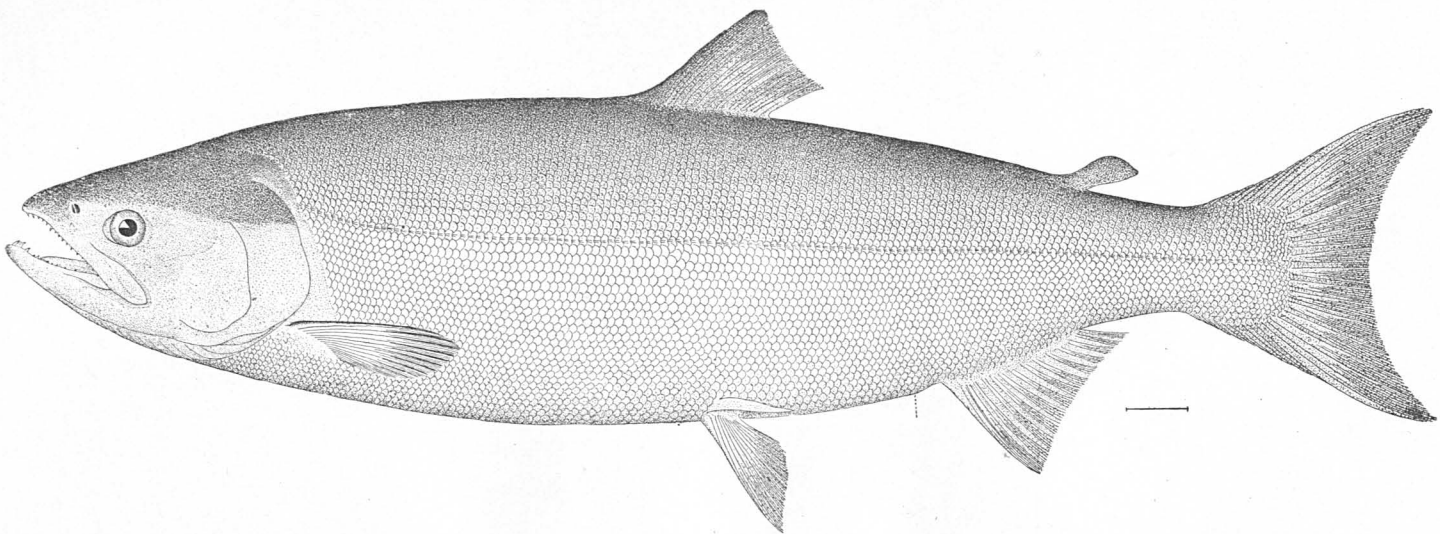

ONCORHYNCHUS NERKA. *Blueback Salmon; Redfish.*

rivers they are comparatively safe from enemies except otters, ospreys, and fishers, but immense numbers are destroyed at the mouths of the streams by seals and sea lions.

The quinnat salmon has been successfully introduced into Australia, New Zealand, and France, and in the latter country it is now being reared successfully as landlocked salmon in fresh-water lakes. Efforts to acclimatize this species on the Atlantic coast of the United States have up to this time been unsuccessful.

THE BLUEBACK SALMON.

Considering the entire west coast, this species (*Oncorhynchus nerka*) is probably more numerous than all the other salmons combined. It is known in different regions under the names blueback, redfish, red salmon, Fraser River salmon, and sock-eye or saw-qui. It ranks next to the chinook in commercial value, being especially important in the Columbia and Fraser rivers and in Alaska. For canning purposes it is but little inferior to the chinook, the color of the flesh being a rich red, which persists after canning. Comparatively few red salmon are sold fresh in the United States. Large quantities are canned in British Columbia and in Alaska, particularly on Kadiak Island, and its commercial importance to that Territory is indicated by the fact that nearly half of the entire salmon pack of the world comes from Alaska and the majority of the fish canned are of this species.

It is next to the smallest of the salmons, the maximum weight being about 15 pounds, but it rarely weighs over 8 pounds and the average weight is scarcely 5 pounds. In various lakes this fish weighs only half a pound when mature, and is called the little redfish.

It ranges from Humboldt Bay, California, to the far north. In general it ascends only those rivers which rise in cold, snow-fed lakes. No more is known of its ocean life than of the quinnat. It appears in the Columbia River with the spring run of the quinnat salmon. In southern Alaska and also at Kadiak Island it comes in numbers in June; the heaviest run is during June and July, the spawning occurring in August and September. In the Idaho lakes, which may be considered typical spawning-grounds for this fish in the United States, the height of the spawning season is from August 25 to September 5, although ripe eggs have been found as early as August 2, and fish with eggs in them as late as September 11. In the numerous affluents of the Fraser River the spawning extends from September 15 to November 15, a few stragglers spawning as late as November 30. They scoop out small circular nests for their eggs in rather shallow water in the inlets of the lakes, where they deposit their spawn, the eggs averaging about 1,000 to 1,200 to the fish.

Except during the breeding season the color of this fish is a clear bright blue above, with silvery sides and belly. At the spawning period the back becomes blood-red in color, the sides dark red, and the male develops an extravagantly hooked jaw.

THE HUMPBACK SALMON.

The humpback salmon (*Oncorhynchus gorbuscha*) is the smallest of the Pacific salmon; its average weight is only 5 pounds, and it is rarely found weighing as much as 10 pounds. Its geographical range is from San Francisco probably as far north as the Mackenzie River, and it is also common on the Asiatic coast. It is the most abundant and generally distributed salmon in Alaska, but in the Pacific States it does not ordinarily occur in great abundance, although there is sometimes a noteworthy run in the Puget Sound region.

In food value the fresh-run humpback is scarcely inferior to any other salmon. While the flesh has a very fine flavor, it is paler than that of other red salmon, and the species has consequently been neglected by canners. It is probable, however, that it will eventually be utilized for canning purposes, and its excellent qualities when fresh are undoubtedly destined to give it a great commercial value. The chief consumption now is by Alaskan natives, who cure large quantities for winter use.

The humpback salmon generally seeks the smaller streams for the purpose of spawning and deposits its eggs a short distance from the sea, sometimes within only a few rods of the ocean. At Kadiak Island, Alaska, where it is often very abundant, it arrives in the latter part of July, the run continuing only a few weeks. Spawning takes place in August. There are only a few hundred eggs to each fish, the eggs being smaller than those of the quinnat but larger than those of the redfish, and paler in color than the eggs of either of those species.

When this salmon first comes from the ocean it resembles a small quinnat, but as the spawning season advances it develops a very large and prominent hump on its back. This, with the distortion of the jaws, gives the fish a very singular appearance. The extreme emaciation and the extensive sloughing of the skin and flesh, which are incident to spawning, result in the death of all the fish, either on the spawning-grounds or after being swept out to sea by the current.

THE SILVER SALMON.

This fish (*Oncorhynchus kisutch*) is known as silver salmon, silversides, skowitz, kisutch, hoopid salmon, and coho salmon. It is a beautiful fish, having a graceful form and a bright silvery skin. The flesh, which is fairly good, usually has a bright red color, but owing to its fading on cooking it is not highly regarded for canning purposes, although large quantities are thus utilized in the Columbia River, Puget Sound, and in the short coast streams of Oregon and Washington. Its average size in the Columbia and Puget Sound is 8 pounds, but in Alaska the average is nearly 15 pounds. It rarely reaches 30 pounds in weight. Its range is from San Francisco to northern Alaska, and as far south on the Asiatic coast as Japan. It runs up the rivers to spawn in late fall or early winter, when the waters are high, but does not ascend great distances from the ocean. The average number of eggs to a fish is about 2,000.

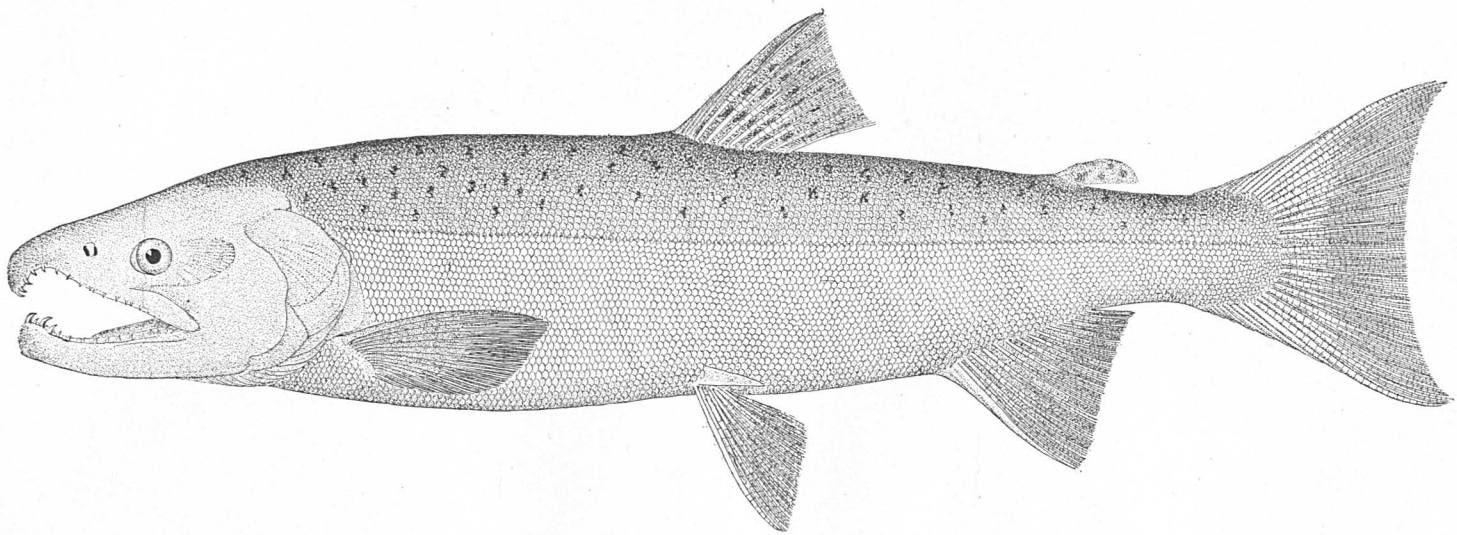

ONCORHYNCHUS KISUTCH. *Dog Salmon.* Breeding male, with distorted jaws.

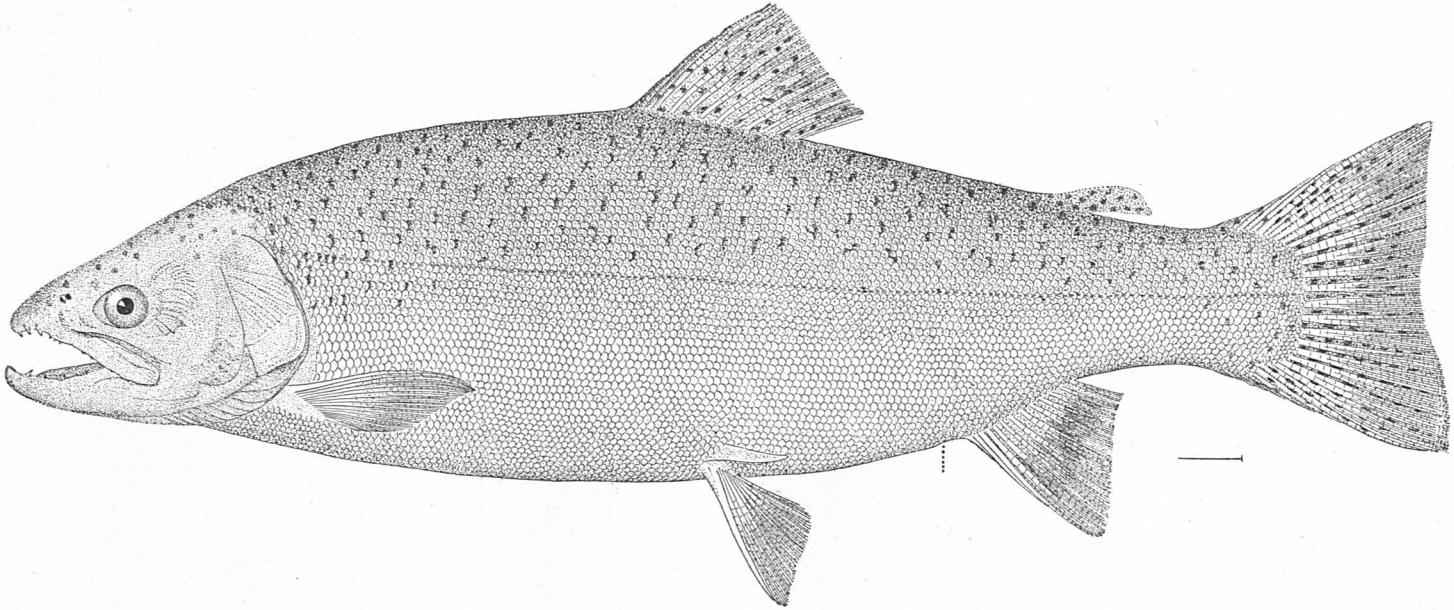

SALMO GAIRDNERI. *Steelhead.*

THE DOG SALMON.

The dog salmon (*Oncorhynchus keta*) is the least valuable of the Pacific salmon, although it is dried in large quantities by the Alaskan natives. Its average weight is 12 pounds and the maximum is about 20 pounds. It is found from San Francisco to Kamchatka, being especially abundant in Alaska. The enlargement and distortion of the jaws give the species a very repulsive look. When just from the ocean, the flesh has a beautiful red color and is not unpalatable, but it deteriorates rapidly in fresh water. Larger quantities are utilized in Puget Sound than elsewhere in the Pacific States.

THE STEELHEAD.

Another anadromous salmonoid fish found on the Pacific coast, popularly regarded as a salmon, is the steelhead (*Salmo gairdneri*), known also as Gairdner's trout, hardhead, winter salmon, square-tailed trout, and salmon trout. It resembles in form, size, and general appearance the salmon of the Atlantic coast, and is distinguished from other Pacific coast salmon by its square tail in the spawning season, its small head, round snout, comparatively slender form, light-colored flesh, and its habit of spawning in spring. It is more slender than the quinnat and consequently not so heavy for its length. The average weight in the Columbia is about 10 pounds, although sometimes a weight of 30 pounds is attained.

Its range is very extended, reaching from Santa Barbara on the southern coast of California to the Alaska Peninsula, and perhaps to the Arctic Ocean, and it is found in almost all the streams of the Pacific States which empty into the ocean. It begins to enter the Columbia in the fall, and is then in prime condition. From this time it deteriorates until the following spring, when, between the months of February and May, spawning occurs. The fish's movements in other rivers on the coast are not materially different, though perhaps it enters the southern rivers earlier and the northern rivers later than the Columbia. Like the chinook, the steelhead ascends rivers for long distances, and it has been found almost as far up the tributaries of the Columbia as the ascent of fish is possible. The eggs are much smaller than those of the quinnat salmon and average 3,000 to 5,000 to the fish.

As the greatest quantities of steelheads are caught in the spring, when they are spawning and in a deteriorated condition, they are not generally esteemed as food. When they come fresh from the sea and are in good condition, however, their flesh is excellent. As the demand for salmon has increased, steelheads have been utilized for canning and they have formed a noteworthy part of the canned salmon from the Columbia River for a number of years past, as well as from the short coast rivers of Washington and Oregon. Their consumption fresh has been increasing yearly and considerable quantities have been sent to the Eastern States in refrigerator cars.

ARTIFICIAL PROPAGATION.

The chinook being the principal salmon that has been propagated artificially, the following chapter is devoted almost entirely to this species. The discussion of the apparatus and methods has special reference to the hatcheries of the United States Fish Commission on the McCloud River and Battle Creek, tributaries of the Sacramento, although cognizance is also taken of the work at the stations in the basin of the Columbia River and on the short coast rivers of California and Oregon.

In 1896 the number of eggs of this fish collected by the Commission was 36,237,000, from which about 32,000,000 fry were hatched and planted. The collections of eggs of the silver salmon numbered 298,137, which yielded 298,000 fry, and of steelhead eggs 604,000, which produced 499,690 fry.

CAPTURING ADULT SALMON.

The adult salmon from which eggs are obtained for the purposes of propagation are taken chiefly with drag or sweep seines, this being the most practical method of collecting them in large numbers. The seines at the United States Fish Commission station at Baird, on the McCloud River, are from 120 to 170 feet long, made of about 28-thread twine, and are 20 feet deep in the middle, tapering down to about 6 feet at the ends; they are double-lead on account of the swift current of the river, and have a 4-inch mesh. In the rack placed across the river to stop the passage of fish it is customary to build large wooden traps in which to capture salmon, and at times, especially during a rain storm accompanied by a marked rise in the river, large numbers of salmon are taken, but at other times only a few, while there is never more than a small percentage of spawning fish secured in this way.

The trap is quite a valuable auxiliary to the seine, but can not be relied on exclusively. Although it will secure many unripe fish, the ripe ones, which are the ones that are wanted, finding an obstruction in their way, settle back to spawning-grounds below and remain there. The trap is simply a square inclosure of vertically placed slats, with an entrance similar to that of an ordinary pound net. The fish in their eager efforts to pass upstream, go through the V-shaped mouth of the trap, and having once entered, are not able to find their way out. Boards are placed over the top of the trap to prevent the fish from leaping out.

Large dip nets have been used occasionally at Clackamas station, in Oregon, the fishermen standing on the rack at night and dipping below it. Toward the end of the season this method secures a considerable number of ripe fish, but it involves much labor and expense, and most of the spawning fish taken with the dip nets would probably have been captured in the regular course of fishing. There being no satisfactory seining-grounds at Clackamas, and the river just below the rack

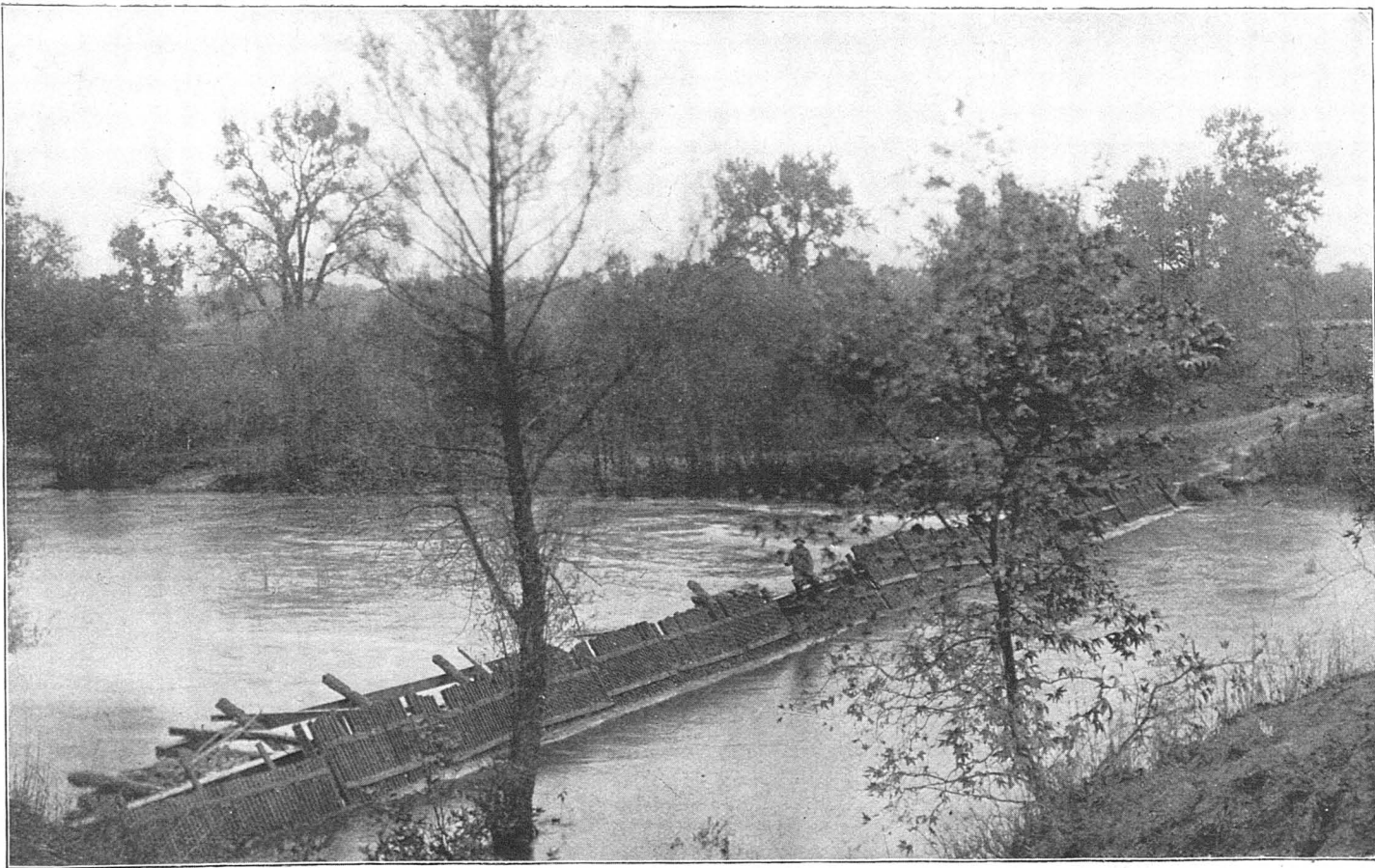

RACK FOR STOPPING ASCENT OF SALMON, AT BATTLE CREEK, CALIFORNIA.

being shallow, an Indian method of fishing is used. The aversion of salmon to heading downstream is well known, but when they are very much frightened they will turn around and rush downstream at their utmost speed. The Indians take advantage of this fact and build a dam of rock or wickerwork, or anything that will present an obstruction to the frightened fish. It is shaped like the letter V, with the angle downstream, and at the angle is a large trap into which the fish are driven. This was at one time the principal method of capturing the breeding salmon at Clackamas, and it worked very satisfactorily. Fyke nets and other fish-catching devices have been employed from time to time, but have been rejected as unsatisfactory.

At Baird, before the rack was employed permanently, seine fishing was usually begun after dark and continued throughout the night, but since the rack has been in use the seine has been hauled more or less in the daytime with perfectly satisfactory results, the fishing generally commencing about 4.30 a. m. and continuing as long as the results warrant it. The work is resumed again about 5 o'clock in the afternoon and continued as long as it meets with success.

RACK FOR CLOSING THE STREAM.

The rack employed as a barricade against the ascending salmon consists of a fence placed across the river and supported by piers heavy enough to prevent the force of the current from pushing them out of position. Log stringers, from 8 to 15 inches in diameter, are laid from pier to pier, to which they are securely pinned, and posts, from 2 to 4 inches in diameter and of the required length, are driven obliquely into the bed of the river, the lower ends being 3 or 4 feet upstream, the upper ends resting on the stringers. Against these posts is laid the rack, which is made in sections, each 6 to 10 feet long, the slats which form them being $1\frac{1}{4}$ inches thick and 3 inches wide, and securely braced at top and bottom. The slats are set $1\frac{1}{2}$ inches apart, and are beveled on the upper side in order to present less resistance to the current. The space between the slats allows ample room for the water to go through, but prevents any salmon from ascending. A wider space between the slats would be preferable, as creating less obstruction to the current, but it would allow a considerable percentage of small grilse (the young salmon after its first return from the sea) to get by the rack, and unless males are quite plentiful the grilse are likely to be needed when the spawning season arrives.

The piers, when first made, are hollow triangles of heavy logs, each layer of logs being firmly pinned to the one below it, until the required height is reached, the apex of the triangle pointing upstream. They are afterwards filled with rocks and are very substantial. Those on the McCloud have been able to withstand the tremendous momentum of the current, even in the highest water.

TAKING AND IMPREGNATING THE EGGS.

After salmon are secured by the seine or other means, they are, for convenience in handling, placed in pens or live-boxes made for this purpose, the ripe or nearly ripe males and females being kept separate. Where the eggs are taken on a large scale, it is desirable to have separate compartments for ripe males, ripe females, nearly ripe females, and males partially spent that it may be necessary to use again, and one or two spare compartments are found to be convenient where large numbers of fish are handled.

Stripping the fish is usually done every day, as the eggs of the females confined in the pens are likely to be injured within the fish, which is a serious objection to keeping the parent fish in confinement any longer than is absolutely necessary.

Of the signs that usually accompany ripeness in a female salmon, the separation of the eggs in the ovaries is the surest, but the specific signs are all fallible, and the spawn-taker relies rather on an indescribable ripe look, which is neither color, shape, nor condition of organs, but a general appearance which shows at a glance that the fish is ripe, and can be appreciated only by experience.

When taking the eggs, one or two men stand ready with dip nets to hand the females to the spawn-taker, and one or more perform the same office with the males. After the salmon are taken from the pens they are held suspended in the net until their violent struggles are over, after which they become quiet enough to be handled and the eggs and milt can be expressed easily.

All methods of taking salmon spawn are very much the same, there being only slight differences in details, chiefly in the manner of holding the parent fish and impregnating the eggs. Where there are plenty of assistants and the salmon are of medium size, the most expeditious way is for the man who takes the spawn to hold the female in one hand and press out the eggs with the other, another in the meantime holding the tail of the fish. The male fish is handled in the same way. This is the method employed at Baird, but on the Columbia, where the salmon are larger and harder to manage, the "strait-jacket," as it is called, is used; this is a sort of trough made the average length of the salmon and hollowed out to fit its general shape. Across the lower end is a permanent cleat, and at the upper end is a strap with a buckle. The fish, when manipulated, is slid into the trough, the tail going down below the cleat, where it is securely held and the head buckled in at the upper end with the strap. It is now unable to do any harm by its struggles and the eggs can be pressed out at leisure. The strait-jacket is almost indispensable with very large salmon and is very convenient when the operators are limited in number.

In impregnating the eggs the main object is to bring the milt and the eggs together as quickly as possible after they have left the fish. By some persons a little water is considered desirable to give greater activity to the milt, but if left more than a minute in the water there

is a decided loss of fertilizing power. The eggs do not suffer so quickly from immersion in water. The absorbing property which they possess when they first leave the parent fish, and which attracts to the micropyle the spermatozoa, lasts several minutes, but it is not prudent to leave the eggs in the water a moment longer than is necessary before adding the milt.

The addition of the water is not essential to a good impregnation; in some instances better results are secured without the use of water and, after all, if the main object is secured, of bringing the milt and the eggs together with the slightest possible delay after they leave the fish, it makes very little difference whether water is used or not. The milt retains its fertilizing power several days when kept from air and water, and impregnation can be effected between fishes widely separated by merely forwarding the milt properly sealed. At Baird impregnation by the dry method, which has always been followed there, has resulted in the fertilization of about 90 per cent of the eggs so treated.

The Russian or dry method of impregnating eggs consists simply in taking both the eggs and the milt in a dry pan. It may be urged as an objection to this method that the eggs will be injured by striking against the dry pan, but it is a fact that although the same eggs would be destroyed by the concussion a week afterwards, or even twenty-four hours afterwards, they do not suffer in the least from it at the moment of extrusion from the fish.

It was at one time considered an important question whether the eggs or milt should be taken first, but with the dry method it makes no difference, as, either way, both eggs and milt remain operative long enough for all practical purposes of impregnation.

Various methods of treating the eggs in the pan after impregnation has taken place have been tried, and all apparently with about the same results. Some operators leave the eggs in the pans as first taken with the milt for two or three minutes and then add water, after which they are left to stand in the pan until they separate, when they are washed clean, taken to the hatching-house, and placed in the troughs. Others pour the contents of the several pans—eggs, milt, and all—into a large can, after they have remained in the pans just long enough to become impregnated. When the eggs separate the contents of the can are poured into the hatching-troughs just as they are, trusting to the current in the troughs to wash the milt from the eggs. Where the water supply is scant and the current sluggish in the trays, the best method is to wash the milt thoroughly from the eggs before placing them in the hatching-trays, as the milt will foul the water if it remains in the troughs.

The methods employed in taking and fertilizing eggs at Clackamas station are as follows: The female fish to be operated upon is taken from a floating pen and placed in the spawning-box or "straight-jacket"; a male fish is then caught and tied with a small rope around

its tail to some part of the corral where he can be quickly caught when needed. One man presses the eggs from the female securely held in the spawning-box, the pan for receiving these being held by another. As soon as the eggs are taken, the male is drawn from the pen by the rope and held by one man, who takes it by the tail with his left hand, its head between or across his knees. With his right hand the milt is then pressed from the fish into the pan containing the eggs as soon as possible after they are taken. The eggs are taken in a pan without any water and milt enough is used to insure its coming in contact with each egg. After the eggs and milt are obtained the pan is gently tilted from side to side and the mass of eggs and milt stirred with the fingers until it is thoroughly mixed. The pan is then filled about two-thirds full of water and left until the eggs separate, the time varying from 1 to 1½ hours, according to the number of eggs and the condition of the atmosphere.

After the eggs cease to stick to each other and to the sides of the pan they are washed clean by repeated rinsings and taken to the hatching-house, where they are measured and put in troughs. The percentage of eggs impregnated varies with different seasons, places, and methods of handling, but it is safe to say that 90 per cent of the eggs taken are impregnated.

The eggs of the quinnat salmon are of a deep salmon-red color. They are heavier than water. Their size varies somewhat, but averages about $\frac{1}{16}$ or $\frac{1}{8}$ of an inch; from 12 to 18 are covered by a square inch. The number in a quart is about 3,700.

HATCHING APPARATUS AND METHODS.

The hatching apparatus generally employed on the Pacific coast in salmon propagation consists of a combination of troughs and baskets. The troughs in common use are the so-called "Williamson troughs," which are 16 feet long, 12 or 16 inches wide, and 6½ inches deep. The troughs are arranged in pairs, and usually two or three pairs are placed end to end on different levels. The fall of water in each trough is 1½ inches. The troughs are divided by double partitions of wood or metal into compartments just enough longer than the baskets to enable the latter to be raised and lowered and to be tilted slightly. The essential feature of these troughs is that at the lower end of each compartment a partition, extending entirely across the trough, reaches from the bottom almost to the top, and another similar partition at the upper end of the compartment reaches from the top almost to the bottom of the trough, each set of partitions being about an inch apart. The water is consequently forced to flow under the upper partition and over the lower partition, and in order to do this it must necessarily ascend through the tray of eggs. The troughs are provided with covers made of canvas stretched upon light frames, and made sunlight proof by saturation with asphaltum varnish. The interior of the troughs is thickly coated with asphaltum.

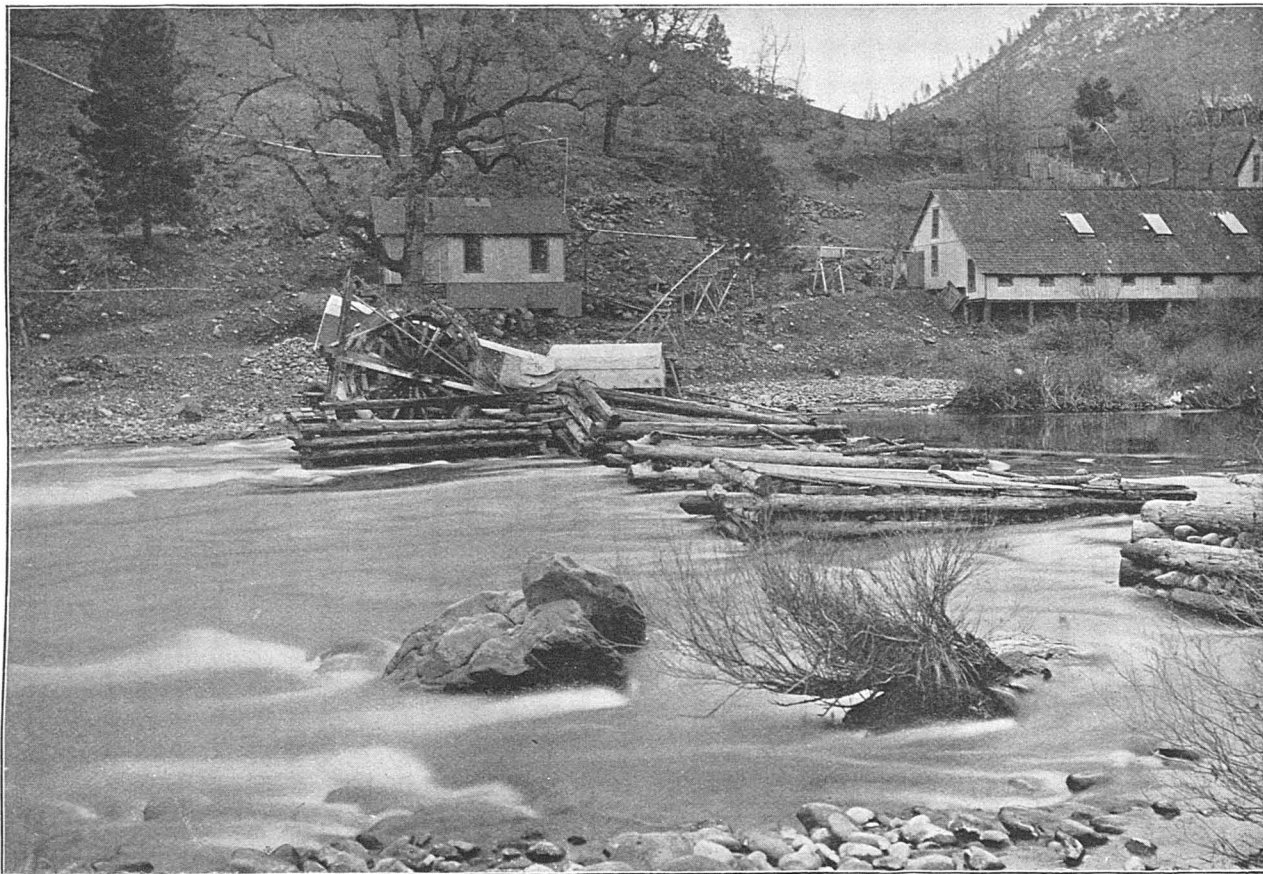

ENGINE-HOUSE AND HATCHERY, BAIRD; CURRENT-WHEEL, AND PIERS FOR HOLDING RACK USED TO STOP ASCENT OF SALMON.

The egg receptacles are deep wire trays or baskets about 12 inches wide, 24 inches long, and deep enough to project an inch or two above the water, which is 5 or 6 inches deep in the troughs in which they are placed. Into each of these baskets 2 gallons of salmon eggs, equivalent to about 30,000, are poured at a time. The eggs suffer no injury whatever from being packed together in this manner, the water being supplied in a way that forces it through the eggs, partially supporting and circulating through them. The meshes are too small to permit the eggs to pass through, although the fry are able to do so.

The advantages of this apparatus and method are:

(1) The top of the tray or basket is out of the water and always entirely dry; consequently, in handling it, the hands are kept dry.

(2) By tilting one end of the tray up and down a little or by lifting it entirely and settling it gently back again in its place the bad eggs will be forced to the top; thus a feather is not required in picking over the eggs and the injuries very often inflicted with it are avoided.

(3) The top of the tray being above water, the eggs can never run over the top nor escape in any way, which is a great advantage over the shallow form of tray.

(4) There is economy of space; 30,000 to 40,000 eggs can be placed in each basket, provided a sufficient quantity of water is available. Two troughs, 16 feet long and 1 foot wide, will by this method carry about 500,000 salmon eggs. The deep trays may be filled at least half full of eggs, and thus ten times as many eggs can be hatched in the same space and with the same supply of water as by the old method. A good but gentle circulation is continually maintained through the eggs.

(5) The deep-tray system is admirably adapted to getting rid of mud that has collected on the eggs, for all sediment accumulating about them can be easily removed by gently moving the tray up and down a few times in the water; but if the deposit of mud on the troughs becomes so excessive as to be unmanageable, a false bottom of wire cloth or perforated zinc can be placed in the troughs at a suitable distance above their real bottom, leaving a space of about 1 or 1½ inches between the wire cloth and the trough bottom. By this means the mud that comes into the trough will sift down into the space below the wire cloth entirely out of the way of the fish, the movements of the fish themselves helping very much to produce this result. Should the accumulation of mud in the space below the false bottom of the trough become too great, it can easily be sluiced out in various ways.

When quinnat-salmon eggs are simply to be matured for shipment, hatching-trays with $\frac{1}{4}$ or $\frac{1}{2}$ inch square mesh will answer the purpose, but when the eggs are to be hatched in them, every alternate strand of wire running lengthwise, or, better still, every second and third thread, should be left out in order to form an oblong mesh through which the newly hatched fry, after separating themselves from the unhatched eggs, can escape from the hatching-trays into the troughs below.

At Baird eggs kept in water averaging about 54° F. hatch in 35 days. The allowance of 5 days' difference in the time of hatching for each degree of change in the temperature of the water is approximately correct.

For the first few days the eggs of the quinnat salmon are very hardy, and at this time they should be thoroughly picked over and the dead ones removed as far as possible before the delicate stage during the formation of the spinal column comes on, so that during that critical period they may be left in perfect quiet. As soon as the spinal column and the head show plainly, the eggs are hardy enough to ship, but when there is time enough it is better to wait a day or two until the eye-spot is distinctly visible, after which time the eggs will stand handling.

PACKING EGGS FOR SHIPMENT. -

The packing-box used in shipping salmon eggs is made of $\frac{1}{2}$ -inch pine, 2 feet square and 1 foot deep. At the bottom is placed a thick layer of moss, then a layer of mosquito netting, then a layer of eggs, then mosquito netting again, then successive layers of moss, netting, eggs, netting, and so on to the middle of the box. Here a firm wooden partition is fastened in and the packing renewed above in the same manner as below. The cover is then laid on the top, and when two boxes are ready they are placed in a wooden crate, made large enough to allow a space of 3 inches on all sides of the boxes. This space is filled with hay to protect the eggs against changes of temperature, and when the cover is put on the eggs are ready to ship.

In the middle of the crate an open space about 4 inches in depth is left, between the two boxes of eggs, for ice. As soon as the crates arrive at the railway station this space, as well as the top of the crate, is filled in with ice. Recent experiments show that salmon eggs can be packed and safely transported to considerable distances when they are first taken.

CARE OF THE FRY.

The eggs of quinnat salmon, like those of other *Salmonidæ*, hatch very gradually at first, only a small proportion of fish coming out the first day. The number increases daily, however, until the climax of the hatching is reached, when large numbers of the young burst their shells in a single day. At this time great care and vigilance are required. The vast number of shells rapidly clog up the guard-screens at the outlet of the troughs, which should be kept as free as possible by thoroughly cleansing them from time to time.

In the deep trays the newly hatched fish are mixed with unhatched eggs, and the advantage of the oblong mesh in the bottom of the trays becomes apparent. This mesh is too narrow to allow the eggs to fall through, but the hatched fish, being comparatively long and narrow, easily slip down through the long meshes into the space below. They should be assisted in accomplishing this by gently raising and lowering

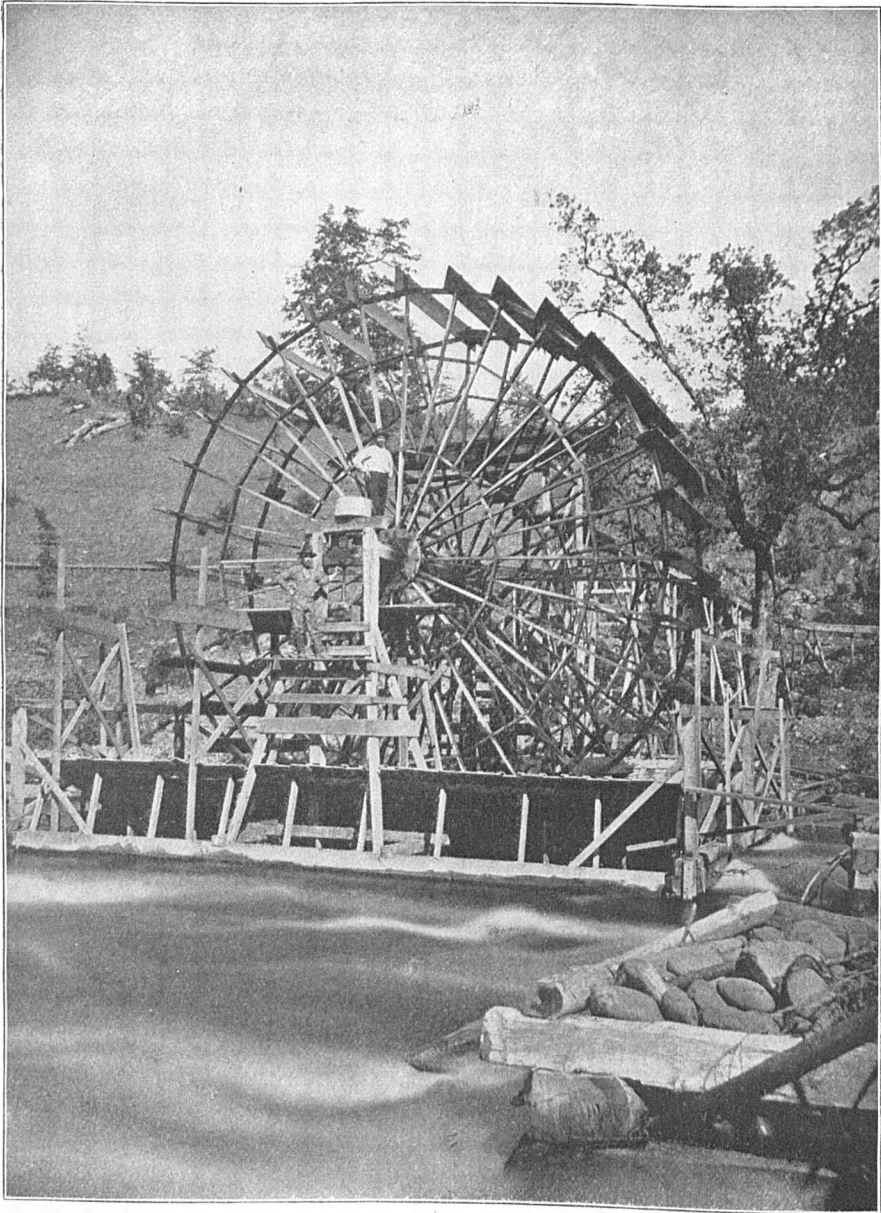

CURRENT-WHEEL FOR PUMPING WATER AT BAIRD, CALIFORNIA.

the tray at intervals, care being taken not to raise them out of the water, as at this tender age a slight pressure against the wire of the tray will often produce fatal injuries. On this account too much caution can not be exercised in regard to handling them out of water during the first stages of the yolk-sac period, for the injuries can not be seen at first, and often the death of the fry is the first warning that they have been injured.

After the eggs are all hatched and the young fish are safely out of the trays and in the bottom of the troughs their dangers are few and they require comparatively little care. Almost the only thing to be guarded against now is suffocation. Even where there is an abundance of water and room, with a good circulation, they often crowd together in heaps or dig down under one another until some of them die from want of running water which is not an inch away from them. The best remedy in such a case is to thin them out.

Eight thousand gallons of water an hour is sufficient for ten lines of troughs 64 feet in length, containing altogether a little over 1,000,000 young salmon in the yolk-sac stage. This gives in round numbers 800 gallons of water to each 100,000 fry every hour, or 16 $\frac{2}{3}$ gallons per minute, which is a safe minimum.

When the yolk-sac has become nearly absorbed the fish rise from the bottom of the trough, where they have previously remained, and hold themselves up in the water. It is now almost time to begin to feed them, and they have become comparatively hardy and require very little care.

Close attention is required again, however, as soon as they commence to feed. They will show when they are ready to feed by darting to one side or the other when small particles of food are dropped in the water and floated past them. From this time, for several weeks, the necessity for care and vigilance never ceases.

The young fish should, for the first few weeks, be fed regularly and as often as six times a day, and the earlier in the day the feeding begins and the later it continues at night the better. Two hours after feeding they will be found to be ravenously hungry, and they grow much faster for frequent feeding and get that growth in their infancy which is indispensable to their ultimately attaining the largest possible size. If they are not fed very often they will bite at one another's fins and so cause more or less mortality among themselves.

ARTIFICIAL FOOD.

The best food for salmon fry is some kind of meat, finely pulverized. Boiled liver is especially good for this purpose, partly because it is inexpensive and easily obtainable, and also because it can be separated into very fine particles. Raw liver is also an excellent food for fry, and may be reduced into as fine particles as the cooked liver by grinding or chopping and then properly straining it through a fine-mesh

screen. The yolk of boiled eggs is also suitable, but it is comparatively expensive and is not so good for the fish as liver unless largely mixed with it.

As the fish grow older they continue to thrive best on meat food, but if that is not always obtainable in sufficient quantities or on account of its expense, a very good substitute is a mixture of shorts or corn meal with the meat. This is prepared as a mush by stirring shorts or middlings into boiling water, a little at a time, so that it will not cook in lumps, but become more of a paste. After it has thoroughly cooked it is allowed to cool and harden. The best proportion is 30 pounds of shorts to 25 gallons of water with 3 or 4 pounds of salt. The percentage of liver to be used in this mixture should be regulated by the age of the fish, feeding the very young fry upon almost a simple meat diet and increasing the proportion of mush with the age of the fish.

Doubtless for young *Salmonidæ* the best natural fish food, not artificially bred, is the roe of fishes which have minute ova, as the best food for the mature fish is live minnows. These foods furnish the fish with a clean, suitable diet and leave no decaying matter on the bottom of the troughs or ponds to foul them or produce disease. But these foods can rarely be obtained without too much expense, although the time will undoubtedly come when perch, carp, and similar coarse fish will be economically propagated and raised to serve as food for trout and salmon. Herring roe is now canned for fish food, and if this can be furnished at a sufficiently low price it may ultimately provide an excellent food for young salmon.

PLANTING THE FRY.

The most prominent instinct of the newly-hatched salmon is to burrow for concealment, and this habit persists until the necessity for active feeding compels them to come from their hiding-places. The retention of salmon in troughs for a number of months after they begin to feed naturally leads to a considerable change in their instincts and makes them less liable to escape from their enemies after being planted. The fry are liberated on the natural spawning-grounds, as a rule, as soon as the umbilical sac is exhausted and they show a disposition to feed at the surface. When, for any reason, the fry are held longer, their growth varies in accordance with the character and temperature of the water in which they are reared and the food they receive. The young fry reared at Baird station grow to a length of $2\frac{1}{4}$ inches from the time when they begin to feed in February until the middle of May, when, on account of the rising temperature of the water, they are liberated in the McCloud River.

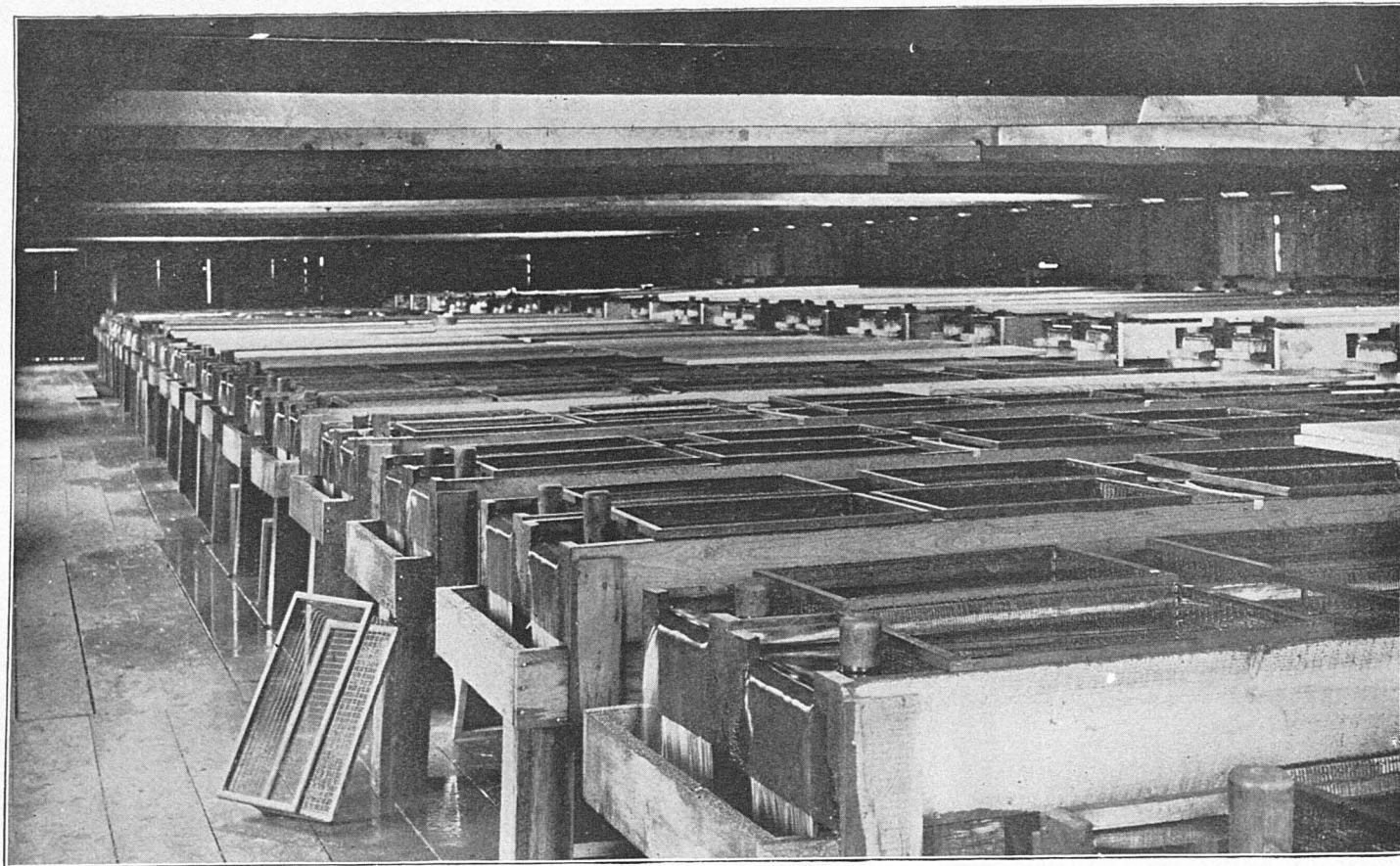

INTERIOR OF HATCHERY AT BATTLE CREEK, SHOWING SALMON BASKET.

SALMON-HATCHING AT BATTLE CREEK.

While the manner of taking and impregnating salmon eggs differs but little at the hatchery of the United States Fish Commission at Battle Creek, California, from that at other places, the magnitude of the operations warrants separate description.

This is now the most remarkable salmon-propagating station in the world, the total number of eggs secured for hatching during the season of 1896 being 25,852,880, which is about 15,000,000 more than have been taken hitherto at any one station. This phenomenal take of eggs would have been still larger had not a flood washed away the rack and allowed the heavy run of salmon to pass upstream.

This station is situated near the mouth of Battle Creek, a tributary of the Sacramento, and although less than 40 miles below Baird station, receives the fall run of salmon only, while at Baird this run is light as compared with the summer run.

Immediately above its confluence with the Sacramento, Battle Creek is deep and lagoon-like for a distance of $2\frac{1}{2}$ miles, and salmon gather there in vast numbers before entering the shallow waters where their spawning-grounds commence. At the head of the lagoon is a retaining-rack similar to that in use at Baird, the fish being taken with a seine just below it.

During the heavier part of the run 500 or 600 are taken at each sweep of the seine, the number at times being more than can be hauled in. The first eggs were taken in 1896 on October 8, and collection continued until the breaking of the rack on November 23, at which time the run of fish was still in progress. Five thousand "ripe" females were taken, averaging 18 pounds in weight. No record was kept of the males, as more could always be taken than were required, but those retained were used day after day until exhausted. Male salmon outnumbered the ripe females 3 to 1.

Spawning operations are conducted upon a floating platform 24 feet long and 12 feet wide, beneath which are nine compartments for retaining the ripe fish, and which are accessible through hinged covers set in the plank flooring. Projecting beyond this platform is another, upon which the actual work of stripping the fish and caring for the pans is performed. It is roofed with tarpaulin, and on three sides is inclosed with burlap.

The taking of spawn is performed by ten men. The method differs but little from that at Baird, except in the manner of handling the fish and the regular use of water in the spawning-pan. One pint of water is placed in the pan before either the eggs or the milt. Two men take the females from the compartments in dip nets and hold them until taken out by the spawn-takers, not allowing them to strike the floor during their struggles. The female is held by two men, one taking the fish from the dip net by the tail, and the other by the head. The stripper then comes between them as the fish is held over the spawning-pan and

presses out the eggs. One man dips the male fish from their compartment and places them on the floor of the platform directly behind the two men who handle them. One holds the fish by the head and the other presses out the milt with one hand as he holds it by the tail with the other, the milt falling into the same pan that receives the eggs and practically at the same time.

The eggs and milt are gently stirred with a feather in the spawning-pan as they are expressed from the fish, and the pan is then placed upon a shelf under a dark curtain, where it remains for $1\frac{1}{2}$ minutes, when the contents are poured into a large galvanized iron bucket nearly full of water, the eggs being placed therein before adhesion takes place. During the season of 1896 a total of 4,968 females were stripped, producing 25,852,880 eggs. The greatest number of females stripped in any one day was 269, yielding 1,392,000 eggs. The spawning crew became very proficient, having stripped as many as 151 females in 60 minutes. Spawning usually takes place during the afternoon and seldom exceeds $2\frac{1}{2}$ hours of active work.

The eggs are transferred by wagons from the spawning platform to the hatcheries in large galvanized-iron buckets, 15 inches deep and 14 inches in diameter, which, when filled with water, hold about 70,000 eggs. The tops of the buckets are covered with canvas, and the average length of time occupied in taking the eggs, transferring them to the hatcheries, and measuring them into the hatching-baskets is 40 minutes.

The two hatcheries at Battle Creek contain 160 hatching-troughs, 68 of those in the building first erected being 16 feet by 16 inches by $6\frac{1}{2}$ inches, while half of the 92 in the other building are of the same size, the remainder being 16 feet by 12 inches by $6\frac{1}{2}$ inches. A head or distributing trough runs lengthwise of each building and receives the water from the settling-tank on the outside. The hatching-troughs are arranged in sections of four bound together. Two abut against the distributing-trough, from which they take their supply of water and carry it to the two troughs below, whence it passes to the escape drain at their lower ends; 24 gallons of water per minute are admitted to each trough, and the average temperature of the water is 52° . At the head of each hatching-trough, 2 inches above the surface of the water, is placed a tin aerator, 10 inches by 4 inches by $1\frac{1}{2}$ inches, the bottom only being perforated; 4 inches from the lower end of each trough a retaining-screen is placed at an angle. Between the screen and the end there is a 2-inch hole in the bottom stopped with a plug which projects above the surface of the water. In cleaning the trough this plug is removed, the increased flow of water causing a strong current through the entire length of the trough, which has a capacity of 200,000 eggs contained in five trays or baskets.

When the eggs reach the hatchery they are washed, measured, and placed in the hatching baskets or trays, 40,000 being placed in the 16-inch and 25,000 in the 12-inch trays. These are made of galvanized

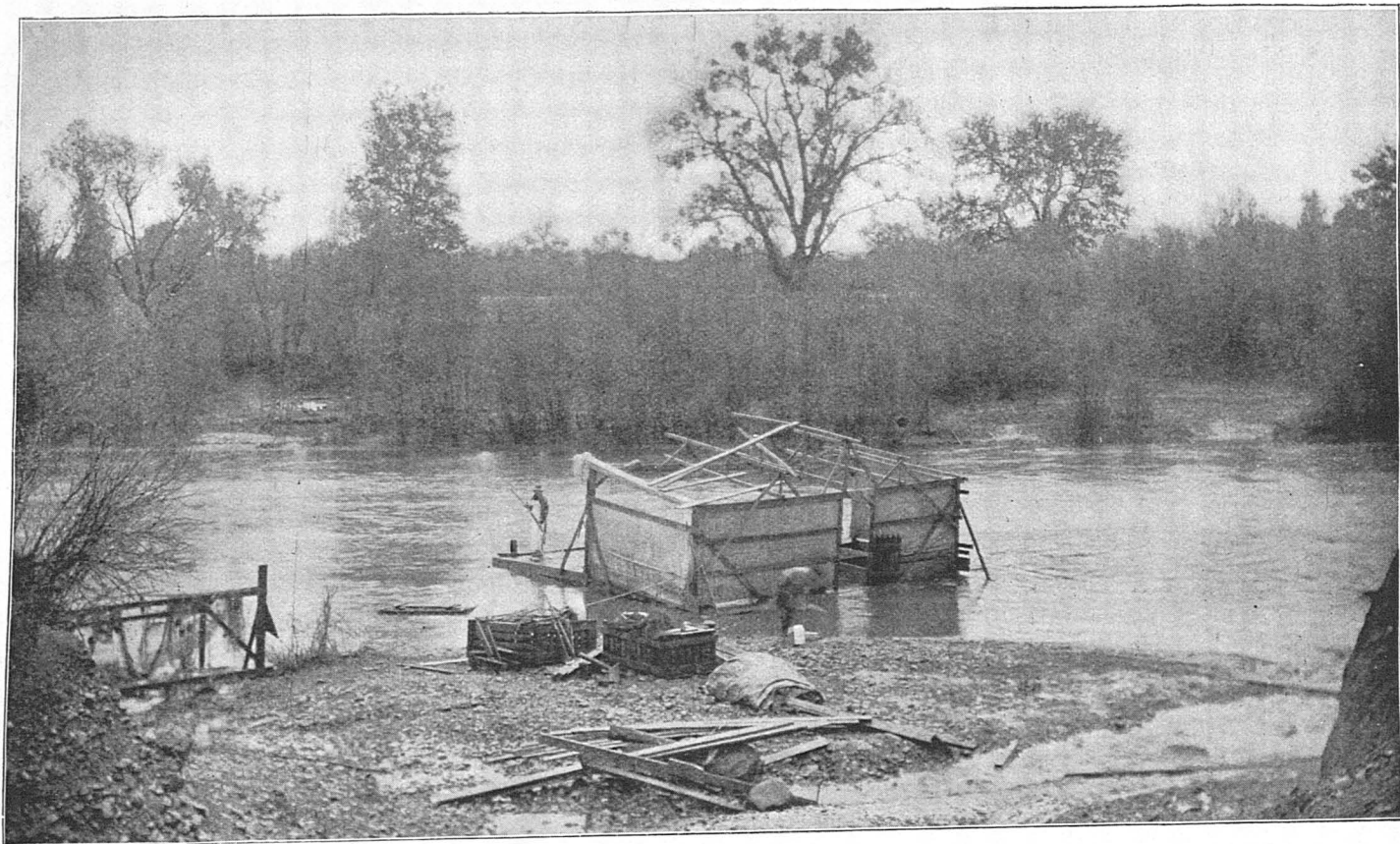

PENS FOR HOLDING RIPE FISH, AND STRIPPING PLATFORM, AT BATTLE CREEK, CALIFORNIA.

iron wire, with meshes $\frac{5}{8}$ by $\frac{1}{8}$ of an inch, fastened at the top to a wooden frame $\frac{1}{2}$ inch thick. They are 23 inches long, $15\frac{1}{2}$ inches wide at top, 15 inches at bottom, and 6 inches deep. When placed in the hatching-trough the wooden frame of the basket rests on the edge of the trough.

Two division plates of galvanized iron are placed in the hatching-trough just above each basket. The first one rests on the bottom and extends to within an inch of the surface of the water; the second is placed half an inch below the first one, and extends from the top of the box to within an inch of the bottom. This causes an upward current of water to pass through the eggs, which, however, is not strong enough to move them.

From the second to the tenth day the eggs are washed and the dead eggs are picked out, but from the tenth to the fifteenth day they are not handled in any manner, no matter how much sediment may cover them. After the fifteenth day, or when the young fish is well defined in the egg, washing and picking is renewed and continued daily until the eggs are packed for shipment.

The method of handling is determined by the conditions, a lower temperature allowing them to be washed beyond the tenth day, but the above noted is the average for the season of 1896. The total loss in eyeing (that is, carrying eggs from time of taking until the eye-spots appear) during the season was 1,308,290, or 5.06 per cent. No eggs were hatched at Battle Creek station, as the water supply was considered unsafe.

In packing eggs for shipment no ice is used except for long distances.

The eggs received at the Sisson station of the California Fish Commission, located at the headwaters of the Sacramento River, are treated by methods similar to those already described as being used at Battle Creek. The average number of days taken to hatch the eggs is 42, and the alevins absorb the sac in from 30 to 40 days at an average temperature of 44° . After the eggs are hatched, the division plates resting upon the bottom of each trough are removed and the remaining plates lowered to within half an inch of the bottom of the hatching-trough. This divides the trough into sections and results in a stiff current running under each plate, which prevents the massing of the alevins at the head of the trough. At this time, a Λ -shaped piece of galvanized iron, termed a harbor plate, is placed in each trough 4 inches above the retaining-screen, with its apex against the current; it extends to within an inch of each side of the trough and rises to the surface of the water. The water in passing around each end of the plate causes an eddy that carries the weak alevins away from the screen into the angle of the plate, affording them a harbor of rest and preventing their being held against the screen.

The loss of alevins while absorbing the sac is slight. The space for hatching-troughs at Sisson is limited; and to relieve the troughs the planting of alevins begins a few days after they hatch; hence the exact

percentage of loss can not be given; but the total loss of alevins at the hatchery the past season was 32,934, or 0.3 per cent, in a total of 10,000,000. The loss after feeding began was very slight, amounting only to 5,716.

The alevins and the fry of the Pacific salmon possess great vitality and are less liable to disease than those of any of the other *Salmonidae*.

The natural conditions for hatching, rearing, and planting fry at the Sisson hatchery are excellent; the water supply is unlimited and is very free from sediment, even during stormy weather, while it has an equable temperature, averaging 52° for the year, seldom falling to 40° or exceeding 60°.

No part of the hatching-house work requires more attention or is of such vital importance as the cleaning of the troughs. Up to the time that the alevins begin to feed the troughs should be thoroughly cleaned once every day by rubbing them down with the hand covered with a coarse crash mitten, and after they begin feeding the troughs require much more attention. One hour after each meal the troughs should be cleaned by passing a bunch of stiff feathers over the sides and bottom, first removing the division and harbor plates and the plug at the foot of the trough.

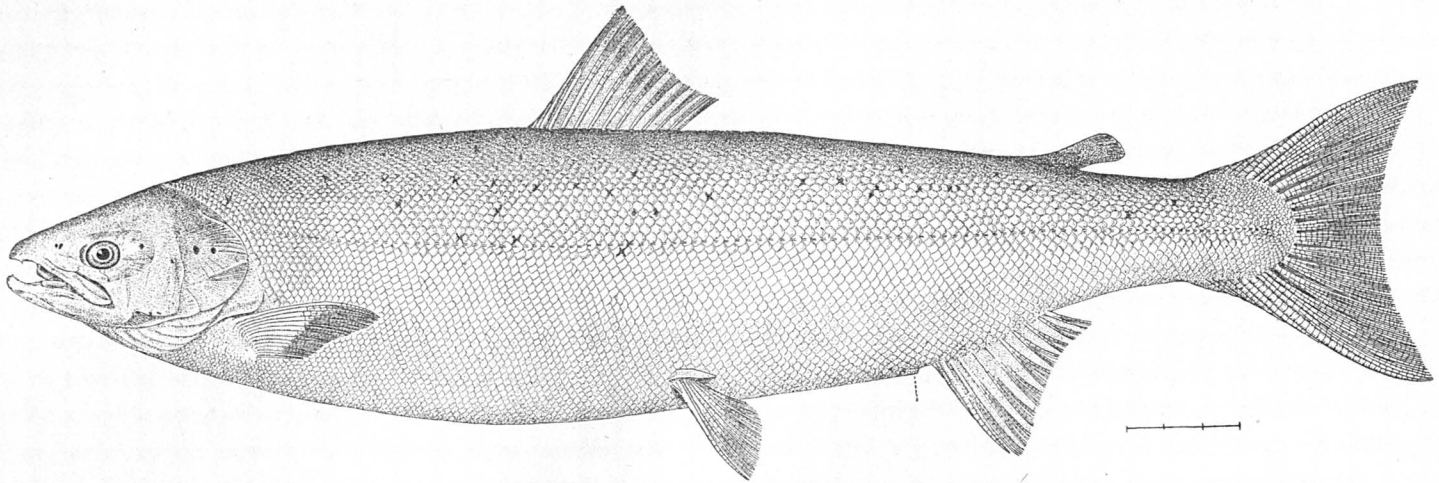

SALMO SALAR. *Atlantic Salmon.*

THE ATLANTIC SALMON.

DESCRIPTION OF THE FISH.

The body of the Atlantic salmon (*Salmo salar*) is moderately elongate and but little compressed; the greatest depth is about one-fourth the total length without the caudal fin. The length of the head is about equal to the body depth. The mouth is of moderate size, the maxillary reaching just past the eye, its length contained $2\frac{1}{2}$ or 3 times in the head. The scales are comparatively large, becoming embedded in adult males; the number in the lateral line is about 120, with 23 above and 21 below that line. The dorsal fin has 11 rays and the anal 9 rays. The pyloric cœca number about 65.

The color, like the form, varies with sex, age, food, and condition. The adult is brownish above and silvery on the sides, with numerous small black spots, often x or xx shaped, on the head, body, and fins, and with red patches along the sides in the male. Young salmon (parrs) have about 11 dusky crossbars, besides black and red spots.

RANGE.

The salmon native to the rivers of the northeastern United States is specifically identical with the salmon of Europe and all the affluents of the North Atlantic. Its original natural range in America appears to have been from Labrador or Hudson Bay on the north to the vicinity of New York on the south. Within these limits, at the proper season of the year, it ascended, for the purpose of reproduction, nearly every river except those that did not afford the requisite facilities for depositing spawn or were inaccessible by reason of impassable falls near their mouths.

In American rivers frequented by Atlantic salmon they were found successively in all parts from the mouth upward, their migrations extending nearly to the headwaters of all the branches so far as they were accessible and adapted to their necessities. The one exception is the river St. Lawrence, where it seems probable, from such evidence as is available, that few if any salmon entering the river from the sea ever ascended as far as Lake Ontario, and that the salmon inhabiting that lake and its tributaries have always, as a rule, made the lake their sea and the limit of their downward migrations. Within or partly within the limits of the United States there can be enumerated twenty-eight rivers that were beyond doubt naturally frequented by salmon, beginning with

the St. John and ending with the Housatonic.* In the greater part of these the species has been exterminated by civilized man, and in the few in which it still persists its numbers are far below the estimates which the earliest records warrant us in making for those days.

In certain lakes of Maine and northward this fish is perfectly landlocked and has somewhat different habits and coloration, but no distinct specific characters. Similar landlocked varieties occur in Europe.

LIFE AND HABITS.

Salmon eggs are deposited on coarse gravel on some rapid, generally far up toward the sources of a river, late in October or early in November, when the water is perhaps about 44° F. and the temperature is falling. The egg is impregnated at the moment of its deposit, and the independent life of the salmon begins to develop at once. In a few weeks the embryo becomes sensitive, but the extreme cold of the water retards its development to such an extent that it does not burst the shell of the egg until spring. In the rivers of New England it is probable that nearly all the eggs naturally deposited hatch very late in April and early in May. At this time the embryo salmon has a slender half-transparent trunk, less than an inch in length, carrying, suspended beneath, an immense ovoid sac—the “yolk-sac.” For about six weeks after hatching it hides in crevices among stones, keeping up an incessant fanning with its pectoral fins. During this period it takes no food, but is supported and nourished by the yolk-sac, the substance of which is gradually absorbed into the rest of the body, and not until the sac has nearly disappeared does the salmon really look like a fish and begin to seize and swallow food. It now puts on a mottled coat, with several heavy dark bars across its sides, and bright red spots, larger and fewer than those of a trout, looking therefore very unlike the adult salmon but much like a young trout. In this stage it is termed, in Scotland and England, a “parr,” and it was formerly thought to be a wholly different species from salmon.

The parr stage lasts a year or two in British rivers, and the few observations made in America indicate that it is more likely two years than one in our rivers. The parr, at first but little over an inch in length, is provided with good teeth and a good appetite, and beginning to feed at a season of the year when the water is almost crowded with small insects and other more minute creatures, it grows rapidly, probably increasing its weight thirty or forty times the first summer. In two years it reaches the length of 6 or 8 inches, and its bright red spots and dark bars have given place to a silvery coat like the adult salmon. It is now termed a “smolt” and is ready to go to sea, which it does with little delay, and passes out beyond the range of man’s

* The Hudson River is by some believed to have been a natural salmon river. Its discoverer, Hendrick Hudson, reported having observed them there, and there is nothing inherently improbable in it, but the evidence is perhaps insufficient.

observation, but to a region where it finds a rich feeding-ground and rapidly increases in size.* In northern rivers, those of New Brunswick and beyond, as in those of northern Europe, the salmon returns from the sea when it has attained a weight of 2 to 6 pounds, and is then termed a "grilse."

In the rivers of Canada, in general, grilse occur in great numbers, coming in from the sea at a later date than the adults, but ascending like them to the upper waters, mingling freely with them, rising to the same fly, and caught in the same weirs. The mesh of the nets is limited by law to a size that takes the adult salmon, but allows the grilse to slip through. To this circumstance it is in part owing that by the time the fish have reached those portions of the rivers suitable for angling there is commonly, if it be late enough in the season, a great preponderance of grilse, so that more of the latter than of the former are taken by the angler. In Nova Scotia many grilse are taken in the Shubenacadie River from August until late in the fall. On the Miramichi, in New Brunswick, grilse make their appearance about July 1, and from the middle of that month till the end of August they constitute the main body of the salmon entering the river. Some sportsmen report that the grilse caught exceed the adults in the ratio of 5 to 1.

In the month of August, in the Nepissiguit, Restigouche, and St. John of Gaspé, grilse have been found in some years to exceed the adults in the ratio of 3 to 1. They run into the Nepissiguit mostly between July 25 and September 1. Their scarcity during the early part of the angling season, or say previous to July 20, is attested by numerous fishing scores. A series of scores of salmon fishing in the Godbout River, on the north side of the St. Lawrence, shows that previous to July 15 or 20 the adult salmon taken with the fly in that river exceed the grilse in the ratio of 10 to 1 or more.

In our rivers grilse are seldom seen, and only 3 or 4 are taken per year in a weir in the St. Croix, which takes about 70 adults. In the Dennys River the ratio of grilse to salmon caught is not more than 1 to 500, and in the Penobscot they are quite as rare. Adult salmon running in this river several weeks earlier than in those of eastern New Brunswick, we

* There has been considerable discussion on this point, and the conclusions of some observers are at variance with the above statement. In Scotland many years ago it seemed to be well established by the observations of Buist that a portion of the young salmon put on the silvery coat and went to sea at the age of one year, but that others of the same brood did not get ready to go until two years old. American observations, however, tend strongly to the conclusion that the young salmon passes two whole summers in the river, going out to sea in the autumn following its second summer or the next spring. It is not probable that the seaward migration is restricted in any river to any exact period of a few weeks duration, but that it extends over many months, some of the young salmon, by reason of superior native vigor of growth or from other equally efficient cause, attaining the migratory stage months earlier than others of the same brood.

It is the opinion of one American observer that salmon fry remain in the streams until October of the second year before going to sea, and that they do not go down until the spring of the third year; i. e., when they are two years old; though some may go down the fall of the second year; and that the salmon do not return until they are four years old.

should naturally expect the advent of grilse early in July in considerable numbers; but some of the weirs are often kept in operation until the middle or last of July, and sometimes even through August, when they take menhaden; but no grilse enter them. During the latter part of the summer the water at the several falls between Bangor and Oldtown is generally at a low stage, and the attempt of grilse, even in small numbers, to ascend the river could hardly fail to be frequently detected. A similar state of things exists in the Kennebec. There is no escaping the conclusion that the great run of grilse, which is so prominent a feature in the history of the salmon of northern rivers, is almost entirely wanting in the rivers of the United States. It by no means follows from this that our salmon do not pass through the same phases of growth, or that the growth is more rapid, but merely that when in the grilse stage they generally lack the instinct that impels their more northern relatives to seek fresh water.

Of the characteristics of grilse, as ascertained in the rivers they frequent, it will be sufficient to say that they exhibit to a great degree the characteristics of the adult; that the main external differences are a shorter head, slenderer form, and a difference in the color and markings; that they are remarkably active and agile, leaping to great heights; that the male is sexually well developed and mates with the adult, but that the female is immature, and that, like the adult, they abstain from food and consequently lose flesh during their stay in fresh water.

The next stage of life of the fish is that of the adult salmon, and this is the stage at which, with the exceptions indicated above, the Atlantic salmon first ascends the rivers of the United States. Assuming that it relinquished the rivers for the sea at the age of two years, being then a smolt, it has been absent two years, and it is now four years or a little more since it burst the shell. This estimate of age is based on the observations made by the Massachusetts commissioners of fisheries on the return of salmon to the Merrimac River, which plainly established the fact that the entire period between the hatching of the fry and the return of the adult to the rivers is about four years. Whether the same rule holds in other New England rivers can not as yet be established, owing to deficient data, but the presumption is in favor of that conclusion. In Canadian rivers the same period of growth appears to be the universal rule, at least as far north as the St. Lawrence River. Statistics of the catch of salmon for many years in eighteen separate districts, showing many fluctuations, exhibit a remarkable tendency of the figures to arrange themselves in periods of five years; thus, the year 1875 having been a year of small catch of salmon, it also appears in most of the districts that the next year of abnormally small catch was 1880. Now, the eggs laid in 1875 would hatch in 1876, and the young hatched at that time would be grown in 1880, requiring thus four years from hatching to maturity, just as on the Merrimac. It would seem no other interpretation can be put upon the statistics.

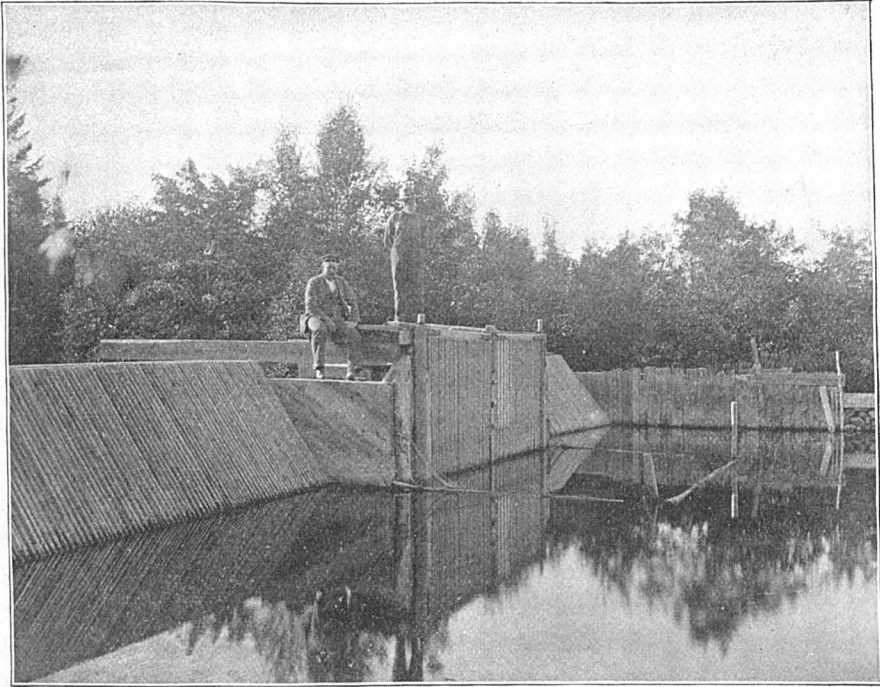

ENTRANCE TO DEAD BROOK INCLOSURE FOR SALMON.

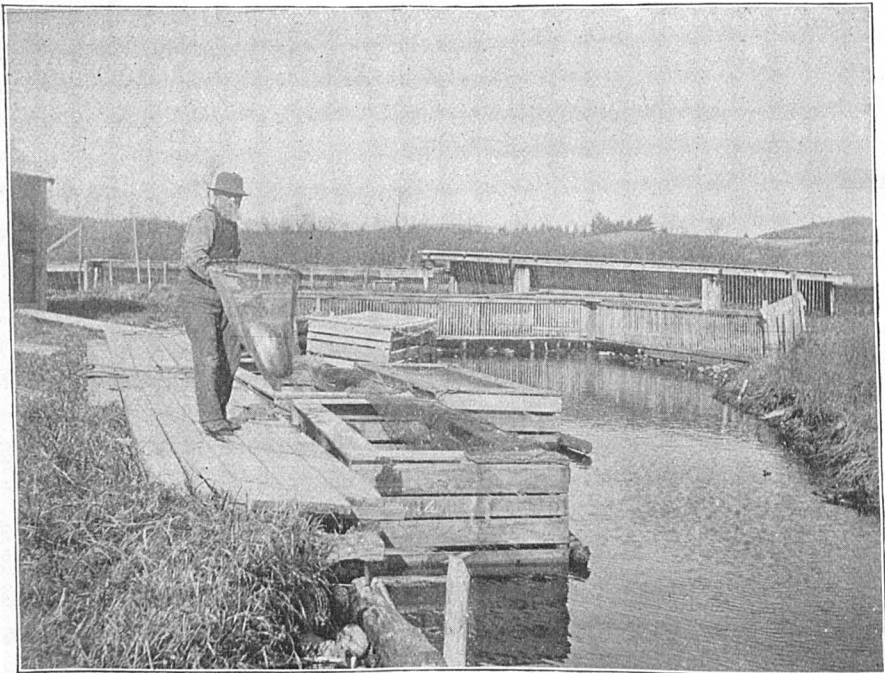

DEAD BROOK INCLOSURE FOR ATLANTIC SALMON, SHOWING PENS.

EARLY SALMON-CULTURE ON THE PENOBSCOT RIVER.

The movement for the reestablishment of the fisheries for salmon, shad, and other anadromous species in American rivers originated in the action of the legislatures of New Hampshire and Massachusetts, having in view primarily the fisheries of the Merrimac and Connecticut rivers. The course of the Connecticut lies partly in the State of Connecticut, while many of its tributaries are in the State of Vermont, and these two States were therefore early interested in the project, and their action soon led to a similar movement on the part of Rhode Island and Maine. The rivers within the borders of these six States are the only ones in the United States known to have been frequented by the seagoing *Salmo salar*, except possibly the Hudson and certain rivers tributary to the St. Lawrence, in the northern part of New York.

The commissioners to whom the governments of the above States confided the task of restocking the exhausted rivers turned their attention at once to the two most important of the migratory fishes, the salmon and the shad. The utter extermination of salmon from most of the rivers compelling the commissioners to consider the best mode of introducing them from abroad, eggs were obtained for a time from the spawning-beds in the rivers of Canada and hatched with a measure of success. After a few seasons permits for such operations were discontinued, and it became essential to look elsewhere for a supply of salmon ova. In 1870 attention was directed to the Penobscot River, in the State of Maine, which, though very unproductive compared with Canadian rivers, might yet, perhaps, be made to yield the requisite quantity of spawn. The fisheries are all in the lower part of the river and in the estuary into which it empties, Penobscot Bay, and there the supply of adult salmon could be found with certainty, but they must be obtained from the ordinary salmon fisheries in June and held in durance until October or November, and the possibility of confining them without interfering seriously with the normal action of their reproductive functions was not yet established.

This plan was finally adopted, and in 1871 this method of breeding salmon was first attempted. For the purpose of the experiment, a point at the mouth of Craig Brook, which is by water nearly 9 miles distant from the mouth of the Penobscot River, more than half the route being through brackish water, was selected as the most convenient fresh-water stream which offered facilities for confining the salmon and maturing their eggs. After some unsuccessful trials means were found of safely conveying a few live salmon in floating cars from the fishing-grounds to the station, where they were held till the spawning season, when their eggs were taken and impregnated.

From 1872 to 1876 operations were conducted on a larger scale, with a fair degree of success, and, after a suspension, were resumed in 1879 at Craig Brook hatchery, while the retaining inclosures were located in Dead Brook, about 2 miles distant. The disadvantage of this

distance between the hatchery and retaining-ponds was offset by other advantageous conditions.

Until 1886 no attempt was made to rear salmon, and with unimportant exceptions the work was confined to the collection of salmon eggs, their development during the earlier stages, and their transfer in winter to other stations to be hatched. In 1889, however, the United States Fish Commissioner decided to establish a permanent station at Craig Brook, and in anticipation of the purchase of the premises, which was concluded the following year, the rearing of salmon to the age of six or seven months was undertaken as the leading work of the station.

COLLECTION OF STOCK SALMON.

The only salmon fisheries available for the purpose of supplying Craig Brook station with breeding fish are those carried on by weirs about the mouth of the Penobscot. Arrangements are made early in the season with weir fishermen to save their salmon alive and deliver them daily to the collecting agent of the station, who makes the rounds of the district about low water with a small steamer, which tows the cars containing the fish on the flood-tide to Orland village, where they are passed through the lock about high water and taken by a crew of oarsmen to the inclosure at Dead Brook.

In anticipation of this work, the fisherman places the floor of his weir a little lower than he would otherwise do, so that at low water the salmon may have water to swim in instead of being left high and dry by the retreating tide, in case of an accidental delay or failure to visit the weir at the usual hour. It is, however, the ordinary practice to take the salmon out at each "fish-tide," i. e., low water, and place them in a car. Cars enough are stationed among the fishermen to bring one at least in each neighborhood, and in most cases the car is brought alongside and the salmon transferred to it directly from the weir, though in some cases it is necessary to place the salmon first in a box, in which it is carried by a boat to the car. The car employed is made from the common dory, divided transversely into three compartments. The central one, which is much the larger, is occupied by the fish, and is smoothly lined with thin boards and covered with a net to prevent the fish jumping out or being lost by the car capsizing, which sometimes occurs, while to guard them from fright and the rays of the sun a canvas cover is drawn over all.

The first cars of this form constructed had iron gratings to separate the central from the forward and after compartments, the water being admitted through the forward and discharged through the after compartment, but this was objectionable because the salmon were constantly seeking to escape through the forward grating, and often injured themselves by rushing against it. Smooth wooden gratings were afterwards used and for many years cars were employed in which the compartments were separated by tight board partitions, the openings for the circulation of water communicating through the sides of

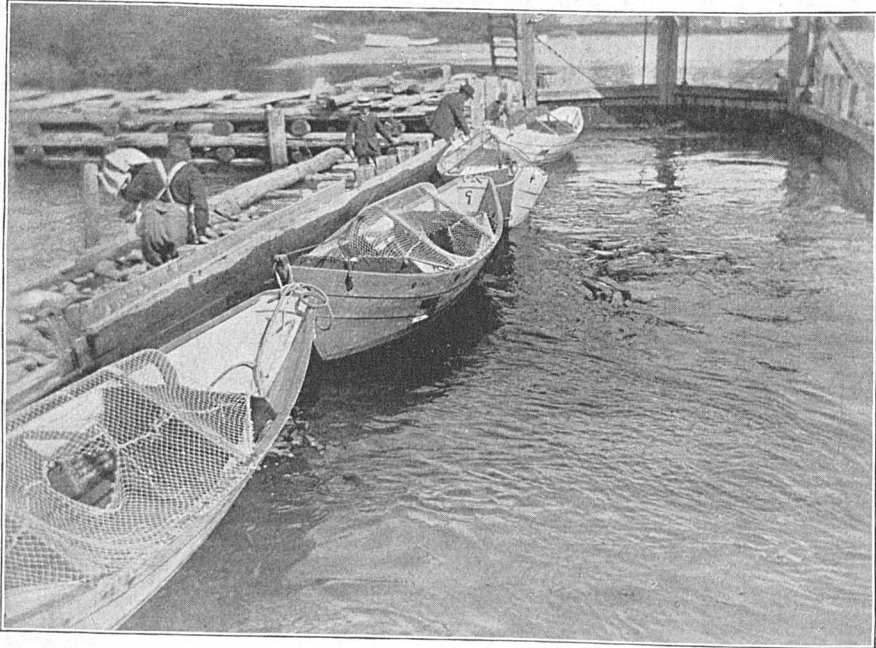

SALMON LIVE-CAR USED IN TRANSPORTING FISH FROM WEIRS TO DEAD BROOK.

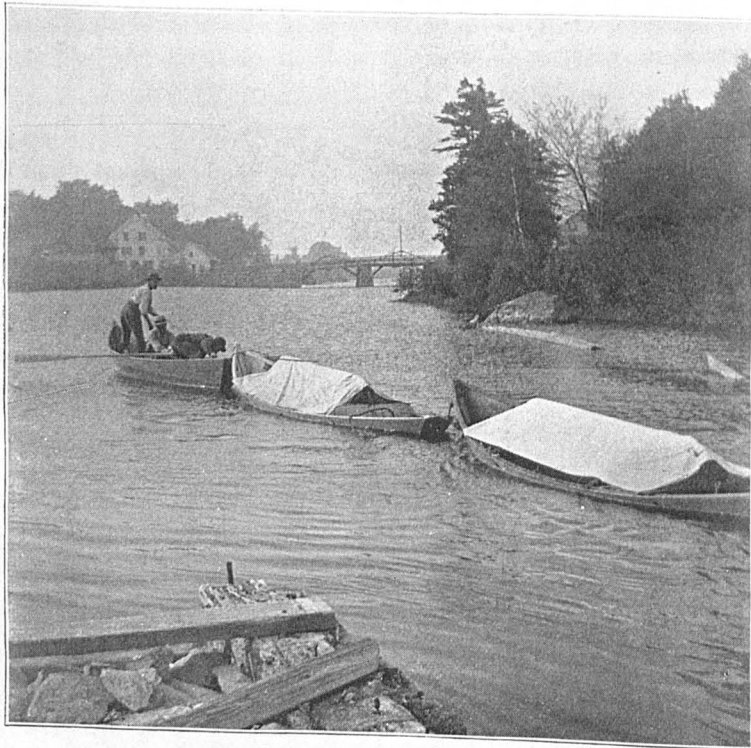

SALMON LIVE-CARS EN ROUTE WITH FISH.

the boat directly with the fish compartment and being, of course, grated. This was very satisfactory, but when it was found desirable and practicable to use ice in transportation, the forward compartment became the ice-room, and it was necessary to perforate the partition again to admit the cold water to the fish. Finally, stout woolen blanket cloth was substituted in the partitions, with eyelet holes wrought in to afford passage to the water. This is the form now in use, in which the water is admitted through openings in the sides to the ice-room, from which it passes through the fish-room to the after room, whence it is discharged. The car is ballasted so that the rail is just above water or, in case of an unusually large load of fish, a little below it. All the openings communicating with the outside are controlled by slides, which can be closed so as to let the car swim high and light when it is towed empty.

The boxes used for the transfer of salmon hold about 90 gallons each, and are 2 feet wide, 2 feet deep, and 3 feet long, with a sliding cover, in the center of which is an inch auger hole for ventilation. Such boxes were used at Bucksport from 1872 to 1874 to convey the salmon on drays from the cars to the inclosure, a distance of a little more than a mile; six or eight salmon were taken at once, the box being filled brimful of water, which was brackish and generally clear and cool. Though the largest fish could not lie straight in the box, and the time occupied in transit was commonly twenty minutes, they as a rule arrived at the pond in good condition.

To avoid injury to the fish in transferring them to the cars, fine minnow dip nets, lined with woolen flannel of open texture, are used. The bow on which the net is hung is 22 inches in diameter, and to secure a net of ample width three ordinary nets, 36 inches in depth, are cut open down one side quite to the bottom, and then sewed together, giving thus three times the ordinary breadth without increasing the depth.

The collection of salmon is begun each season usually from the 20th of May to the 1st of June, but as the maximum temperature that the fish fresh from the weirs will endure is about 75° F., the temperature of the water through which the cars are towed must be taken into consideration, and the collection not be postponed until too late in the season. If the collection is prolonged, this difficulty is obviated by using ice, as it has been found that by moderating the volume of water passing through the car and introducing it all through the ice compartment it is possible to keep a uniform temperature in the compartment in which the fish are held several degrees below that of the water in the river, thereby insuring the safe transfer of the salmon.

THE DEAD BROOK INCLOSURE.

The principal sources of Dead Brook are two small lakes, and on some of the tributaries there are considerable springs. While the water is slightly purer than that of ordinary brooks, it is by no means

so transparent as that of Craig Brook, and the bottom can hardly be seen at the depth of 4 feet. This circumstance is regarded as favorable. The inclosure is located on the lower stretches of the brook, not more than half a mile from its mouth, with low banks on either hand and a very gentle current flowing over a bed that is for the most part gravelly but in part consists of a peaty mud that supports a luxurious growth of aquatic vegetation. The general depth is less than 4 feet, but two of the pools are 8 feet deep and another is 6 feet deep. The width of the stream is from 20 to 80 feet. The inclosure occupies the entire stream for a distance of 2,200 feet, embracing an area of about $2\frac{1}{2}$ acres. At either end is a substantial barrier, consisting of wooden racks, which obstruct the current very slightly but confine the salmon securely. The lower barrier is provided with a gate, which swings open to admit boats, and at the upper barrier are located the spawning-house and watchman's camp and a small storehouse.

The temperature of the water during the summer months generally ranges between 60° and 70° F., but the surface temperature occasionally rises to 76° , 80° , and even 84° . During sultry weather the temperature at the bottom has been observed and in the deeper pools has been found to be notably lower than at the surface. Thus a temperature of 75° at the surface has been found to be accompanied by 68° at the bottom; 78° by 74° ; and 81° by 72° . It is probable that to the existence of these deeper pools the survival of the salmon through extremely hot weather may be ascribed.

After their liberation in the inclosure the salmon are at first quite active, swimming about and often leaping into the air. This continues for several weeks. After that they become very quiet, lying in the deepest pools and rarely showing themselves until the approach of the spawning season.

Most of the deaths occur during the first few weeks of their imprisonment, doubtless in consequence of injuries received in capture or during transfer, though high temperature in the inclosure itself about the time of the introduction of the salmon may be one of the causes of mortality. Fish that escape the dangers of June appear to become acclimated and able to endure the high temperatures of July and August without injury.

Notwithstanding salmon enter the rivers in spring or early summer, ascending at once to their upper waters and there, in fresh water, awaiting the spawning season, fresh water is not essential to the activity of their reproductive functions. At the Canadian fish-breeding station of Tadoussac, where salmon are almost the only fish cultivated, it has for many years been the practice to hold their brood fish in an inclosure supplied with salt water, which flows and ebbs through the barrier confining the salmon, and the development of eggs and milt is in no wise unfavorably affected.

WATER FOR A SALMON HATCHERY.

The first requisite for a salmon hatchery is an ample supply of suitable water, on a site where it can be brought completely under control and the proper fall secured. In this matter there is quite a range of choice. The very best is the water from a stream fed by a clean lake of considerable depth, taken a short distance below the outlet of the lake, with an intervening rapid. Craig Pond may be taken as an example of such a lake. It has an area of 231 acres, an extreme depth of 69 feet, and a depth of 25 feet within 500 feet of the outlet. The depth directly influences the temperature and, other things being equal, a deep lake will afford water more uniform in temperature than a shallow one—cooler in summer and warmer, though never too warm, in winter. Such water is commonly quite even in volume and temperature, and comparatively pure. It is cold in winter and warms up slowly in spring, assuring a slow, normal development of the eggs, which is more conducive to health and vigor than a quicker development. The passage down a rapid will further improve this water by charging it highly with air.

After this, the water of a brook is to be chosen that is fed largely by springs, so as to insure constancy in the supply and some moderation of the temperature on warm days, but it is better to have the water flow a long distance in an open channel before using, and, if possible, over a rough and descending bed, that it may be well aerated, and in cold weather somewhat cooled down from the temperature with which it springs from the ground.

Thirdly, choose pure spring water; but in all cases where this is necessary provide a cooling and aerating pond, that the original warmth of the water may be subdued by the cold of the air before it reaches the hatching-troughs, and that it may absorb more or less air by its wide surface.

Lastly, choose ordinary river or brook water, as clean as possible. The latter are considered inferior to spring water by reason of their liability to floods, drought, muddiness, and foulness of other sorts, and in cold climates to anchor ice. Between these different sorts there is of course an infinite number of gradations. If lake water can not be obtained it would be of some advantage to have a supply of both spring water and brook water, depending for ordinary use on the brook water or a mixture of the two, and on the spring water for emergencies, such as the freezing, drying, or excessive heating of the brook, floods with accompanying muddiness, etc. Avoid water coming from boggy and stagnant ponds and marshes; for though excellent water, capable of bringing out the most vigorous of fish, may sometimes be had in such places, yet when not supplied by springs it is dependent for its freshness and good qualities upon rainfalls, and if these fail, as they are liable to, the water may become foul and unfit. It must be borne in mind that these remarks about the selection of water for fish-cultural purposes apply only to the culture of Atlantic or landlocked salmon, in a climate like that of the State of Maine.

It is best to select a site for a hatching establishment in time of extreme drought, and if it then has an ample supply of pure, sweet water the first requisites are fulfilled. It is well also to visit the place in time of flood and, if in a cold climate, in severe winter weather, to learn the dangers to be guarded against on those scores. The volume of water necessary will depend mainly on the proposed capacity of the establishment, the temperature of the water, its character as to aeration, and the facilities existing for the aeration and repeated use of the water. With water of the highest quality and low temperature, and with unlimited facilities for aeration, possibly a gallon a minute, or even less, can be made to answer for the incubation of 100,000 eggs of salmon. As the temperature rises or the facilities for aeration are curtailed a larger volume becomes necessary. In case of spring water, cooled only to 40° and aerated only by exposure to air in a pool of about a square rod surface, with no facilities in the house for aeration, and with the eggs and fry crowded in the troughs at the rate of 4,000 per square foot, 4 gallons a minute is the least that can be allowed, while 6, 8, or 10 gallons per minute are better. While the minimum is, as stated above, possibly less than a gallon a minute, it is not advisable to trust to less than 3 gallons per minute for each 100,000 eggs under the most favorable circumstances.

If the water supply is drawn from a small brook or spring, it is necessary to measure the volume approximately, which is easily done, in the following manner: With a wide board 1 inch thick, having a smooth inch hole bored through the middle, a tight dam is made across the stream so that all the water will have to flow through the hole. If the water on the upper side rises just to the top of the hole, it indicates a volume of 2.3 gallons per minute; a rise of half an inch above the top of the hole indicates a volume of 3.5 gallons per minute; 2 inches rise, 5 gallons per minute; 3 inches, 6 gallons per minute; 6 inches, 8 gallons per minute; 13 inches, 12 gallons per minute. If two 1-inch holes are bored, the same will, of course, indicate twice the volume. The volume of water flowing through holes of different sizes is in proportion to the squares of their diameters; thus a 2-inch hole permits the passage of four times as much as a 1-inch hole. A cylindrical tube whose length is three times its diameter will allow 29 per cent more water to pass than a hole of the same diameter through a thin plate or board.

SITE.

After a satisfactory supply of water is found a site for the hatching-house must be selected that affords facilities for creating a head of water to provide for the requisite fall into and through the troughs, security against inundation, security against too much freezing if in a cold climate, and, finally, general safety and accessibility. The fall required in the hatching-house can hardly be too great. The minimum is as low as 3 inches, but only under the most favorable circumstances

in other respects will this answer, and even then it is only admissible where there is an ample supply of aerated water and the troughs are very short and there is absolutely no danger of inundation; and this fall has the disadvantages of the impracticability of introducing any aerating apparatus and the necessity of having the troughs sunk below the floor of the hatching-house, which makes the work of attending the eggs and fish very laborious.

A fall of 1 foot will do fairly well if there is entire safety from inundation, as this will permit the troughs being placed on the floor, which is a better position than below it, though still an inconvenient one, and some of the simpler aerating devices can be introduced. Better is a fall of 3 feet, and far better a fall of 6 feet. The latter permits the placing of the lowest hatching-troughs 2 feet above the floor and leaves ample room for complete aeration. The necessities of the case are dependent largely upon the volume and character of the water, and if there is plenty of it, well aerated before reaching the hatching-house, there is no occasion, in a small establishment, of additional aeration in the house, and therefore no need of more than 3 feet fall.

Inspection of the premises at time of floods will suggest the safeguards necessary to provide against inundation. If located by a brook-side, the hatching-house should not obtrude too much on the channel, and below the house there should be an ample outlet for everything that may come. By clearing out and enlarging a natural watercourse much can often be done to improve an originally bad site.

In a cold climate it is an excellent plan to have the hatching-house partly under ground, for greater protection against outside cold. When spring water is used there is rarely any trouble, even in a cool house, from the formation of ice in the troughs; but water from lake, river, or brook is, in the latitude of the northern tier of States, so cold in winter that if the air of the hatching-house is allowed to remain much below the freezing-point ice will form in the troughs and on the floor to such an extent as to be a serious annoyance, and if not watched will form in the hatching-troughs so deeply as to freeze the eggs and destroy them. Stoves are needed in such climates to warm the air enough for the comfort of the attendants; but the house should be so located and constructed that it may be left without a fire for weeks without any dangerous accumulation of ice, and if the site does not permit of building the house partly under ground the walls must be thoroughly constructed and banked well with earth, sawdust, or other material. In warmer climates no trouble will be experienced from this source.

DAMS AND CONDUITS.

The requisite head of water can often be had by throwing a dam across the stream and locating the hatching-house close to it. The dam will form a small pond, which will serve the triple purpose of cooling, aerating, and cleansing the water. But unless the character of the bed and banks of the stream are such as to preclude any danger

of undermining or washing out the ends of the dam, it is best not to undertake to raise a great head in this way. With any bottom except one of solid ledge there is always great danger, and to guard against it when the dam is more than 2 feet high may be very troublesome. If there is a scarcity of water, or if it is desirable, for aerating or other purposes, to secure a considerable fall, it is better to construct the dam at some distance above the hatching-house, on higher ground, where a very low dam will suffice to turn the water into a conduit which will lead it into the hatching-house at the desired height.

A square conduit made of boards or planks, carefully jointed and nailed, is in nearly all cases perfectly satisfactory, and for an ordinary establishment a very small one will suffice.

The volume of water that will flow through a pipe of a given form depends upon its size and the inclination at which it is laid. A straight cylindrical pipe, 1 inch in diameter, inclined 1 foot in 10, conveys about 11 gallons of water per minute. The same pipe, with an inclination of 1 in 20, conveys 8 gallons per minute; with an inclination of 1 in 100, it conveys 3½ gallons per minute; with an inclination of 1 in 1,000, it conveys 1 gallon per minute. A 2-inch pipe conveys about 5½ times as much water as an inch pipe; a 3-inch pipe nearly 15 times as much. A 1-inch pipe, with an inclination of 1 in 1,000, conveys water enough for hatching 25,000 eggs; with an inclination of 1 in 50, enough for 100,000 eggs; with an inclination of 1 in 20, enough for nearly 200,000 eggs. A square conduit conveys one-quarter more water than a cylindrical pipe of the same diameter. If there are any angles or abrupt bends in the pipe, its capacity will be considerably reduced. It should be remembered that if the water completely fills the aqueduct it is entirely shut out from contact with the air during its passage, whereas if the pipe is larger than the water can fill, the remainder of the space will be occupied by air, of which the water, rushing down the incline, will absorb a considerable volume and be greatly improved. It is therefore much better to make the conduit twice or thrice the size demanded by the required volume of water. If the bottom and sides are rough, so as to break up the water, so much the better, and the wider the conduit is the more surface does the water present to the air.

AERATION.

The water which fishes breathe is but the medium for the conveyance of air, which is the real vivifying agent, without which fish and eggs will die, and with a scanty supply of which the proper development of the growing embryo is impossible. Water readily absorbs air whenever it comes in contact with it, and the more intimate and the longer continued the contact the greater the volume it will absorb. The ample aeration of the water to be used in the hatching-house has already been mentioned as a desideratum of the first importance, and some of the devices by which it is to be secured have been alluded to.

Water from either a brook or a river that has been torn into froth by

dashing down a steep bed has absorbed all the air that is needed in 10 or 20 feet of hatching-trough, and demands no further attention on this score; but if the water is taken from a lake, a spring, or a quiet brook it contains less air, which may be so reduced before it gets through the hatching-house as to be unable to do its proper work. It is therefore desirable to adopt all practicable means of reinforcing it. If the site of the hatching-house commands a fall of 5 feet or more, the object may be attained by contriving in the conduit outside the house, or in the hatching-troughs themselves, a series of miniature cascades.

The broader and thinner the sheet of water the more thoroughly it is exposed to the air, and if, instead of being allowed to trickle down the face of a perpendicular board, it is carried off so that it must fall free through the air, both surfaces of the sheet are exposed and the effect doubled. If practicable, it is best to aerate in the conduit, which, as already suggested, may be made wide and open for that purpose.

If aeration can not be effected outside the house it may be done inside by arranging two long troughs side by side, leveled carefully, so that the water is received in one of them and poured over into the other in a sheet the whole length of the trough. In the hatching-troughs themselves there is an opportunity for aeration either by making short troughs with a fall from one to another or by inclining the troughs and creating falls at regular distances by partitions or dams, each with its cascade, after the fashion already described. The only serious difficulty is encountered where the ground is very flat, so that the requisite fall can not be obtained, and in this case the best that can be done is to make a very large pool, several square rods at least, outside the house, and make all the conduits as wide as possible, so that the water shall flow in a wide and shallow stream.

It will of course be borne in mind that the better the aeration the smaller the volume required to do a given work, and on the other hand it is equally true that the greater the volume the less aeration is necessary. When so large a volume as 6 gallons per minute for every 100,000 eggs is at command, a comparatively small amount of aeration will answer. But, so far as known, the higher the degree of aeration the better the result, without limit, other things being equal, and it is therefore advised to make use of all the facilities existing for this purpose.

FILTERING.

Before the introduction of wire or glass trays for hatching fish eggs it was customary to lay them on gravel, and it was then absolutely necessary to filter all but the purest water. Even ordinary spring water deposits a very considerable sediment, which might accumulate upon the eggs to such an extent as to deprive them of a change of water and smother and destroy them. When, however, eggs are deposited on trays arranged for a circulation of water beneath, as well as over them, as described below, even though their upper sides are covered with sediment, they are clean and bright underneath and remain in

communication with the water beneath the tray, though of course the circulation of the water through the tray is not perfect. It is not, therefore, deemed necessary to introduce any considerable devices for filtering water which is naturally very pure, like lake and spring water when not subject to intermixture with surface water during rains; but where it is necessary to use water subject to constant or occasional turbidness some method of filtering is indispensable.

In the majority of cases at least a portion of the water supply is obtained from an open brook, lake, or pond, and measures must be taken to get rid of the leaves and other coarse rubbish brought down by the stream or conduit. A great deal of such material is encountered in a stream at all seasons, but during fall and early winter it is especially abundant, and to secure entire safety from a stoppage of the water, and consequent loss, a screen on a generous scale must be provided.

A description of the means adopted at this station for providing a temporary extra water service of several hundred gallons per minute, taken from Craig Brook, will serve as an illustration: A tank or vat, 12 feet square and about 2 feet deep, is built in the bed of the brook with a tight dam of stones, gravel, loam, and leaves (these to stop small leaks) running ashore on either side, so that the entire volume of the brook passes over the tank. The bottom and sides are tight and strong, and both bottom and top are inclined about 6 inches down the stream. The cover is of spruce lumber sawed $1\frac{1}{2}$ inches square, and nailed on in the direction of the current, with interstices open half an inch; when in operation the water fills the tank and runs over the lower edge, which is raised enough to maintain a depth of several inches over nearly the whole tank. All leaves and other materials floating near the surface of the water are carried over, together with most rubbish which floats deep. At one of the lower corners of the tank, near the bottom, is a gate about 15 inches square, which is hung by hinges on its upper side. It opens inward, and is closed tightly by the pressure of the water; but it can be easily opened by pushing with a pole from without, and then serves as a floodgate, whereby the tank may be thoroughly cleaned out.

At the other lower corner is a conduit, 6 by 9 inches, which takes from this "leaf-screen" a supply of water not entirely free from rubbish, but so nearly so that a filter of moderate capacity can cope with what remains. A very useful adjunct would be a second horizontal screen of similar construction, through which the water that has passed downward through the first screen, as described, should next pass upward through the second; the first screen would remove floating debris, the second such as is heavier than water.

The filter, situated about 70 feet from the leaf-screen, consists of a wooden flume, 12 feet long and 4 feet deep, divided lengthwise into three compartments, of which the central contains fine gravel held in place by a rack on either hand, of which the interstices are $\frac{1}{2}$ inch wide and $1\frac{1}{2}$ inches apart. The water from the leaf-screen is introduced into one

of the lateral compartments, and filters through the gravel into the opposite compartment, from which it is taken by a plank aqueduct, 6 by 6 inches, to the hatchery. Under the conditions described, and with a fall of about 1 foot from supply to discharge, this filter discharges over 300 gallons of water per minute into the aqueduct—water not absolutely pure, but sufficiently free from coarse dirt for the purpose. In many cases, where small quantities of water are used, it is customary to filter through flannel screens in the hatchery, and such filters do very good service. They can be introduced into the egg-troughs, or by running them lengthwise of a trough a very large volume of water can be filtered.

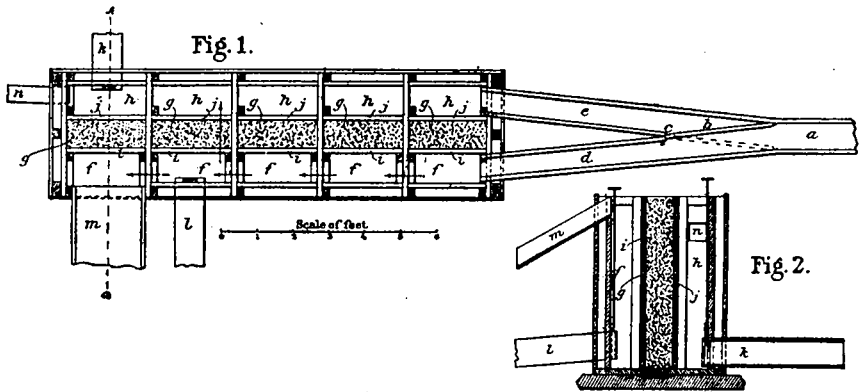

Gravel Filter.

- | | |
|--|---|
| <p><i>a</i>, conduit from brook.
 <i>b</i>, gate, swinging on pivot at <i>c</i>, to change direction of water.
 <i>d</i>, direct branch of conduit.
 <i>e</i>, reverse branch of conduit.
 <i>f, f, etc.</i>, a single long compartment for unfiltered water.
 <i>g, g, etc.</i>, compartments occupied by gravel.</p> | <p><i>h</i>, a single long compartment for filtered water.
 <i>i, j</i>, racks to hold gravel in place.
 <i>i</i> is in 5 sections, movable, and can be taken out when gravel is to be renewed.
 <i>k, l</i>, sluices near bottom for cleaning out.
 <i>m</i>, wasteway.
 <i>n</i>, aqueduct to hatchery.</p> |
|--|---|

A form of filter that has given good satisfaction at the Craig Brook station through five years of service consists in a series of graduated wire screens, through which the water passes upward, first through the coarser, and then through the finer screens, with provision for the reversal of the current for cleaning purposes. By reference to the above plan and section, it will be seen that the water is brought to the filter through a plank conduit, and is admitted to the filter through either of two gates that swing on hinges, one for the direct flow and the other for the reversal. The direct flow is first into a receiving chamber, which extends under the screens, then upward through the whole series and out at the top, overflowing into a catch-trough, from which it is distributed as desired. In cleansing, the supply-gate is closed and the other one opened, and at the same time the sluice-gate at the bottom is opened; the water then flows in full volume upon the screens and down through them, carrying all the intercepted debris into the lower chamber and out through the sluice-gate.

The wire filter illustrated has to pass some 500 gallons of water per minute, and has three screen-boxes, each of which carries 5 to 7 screens about 2 feet wide and 4 feet long; the meshes are from 2 inches down to $\frac{1}{8}$ inch square, and therefore intercept all coarse debris.

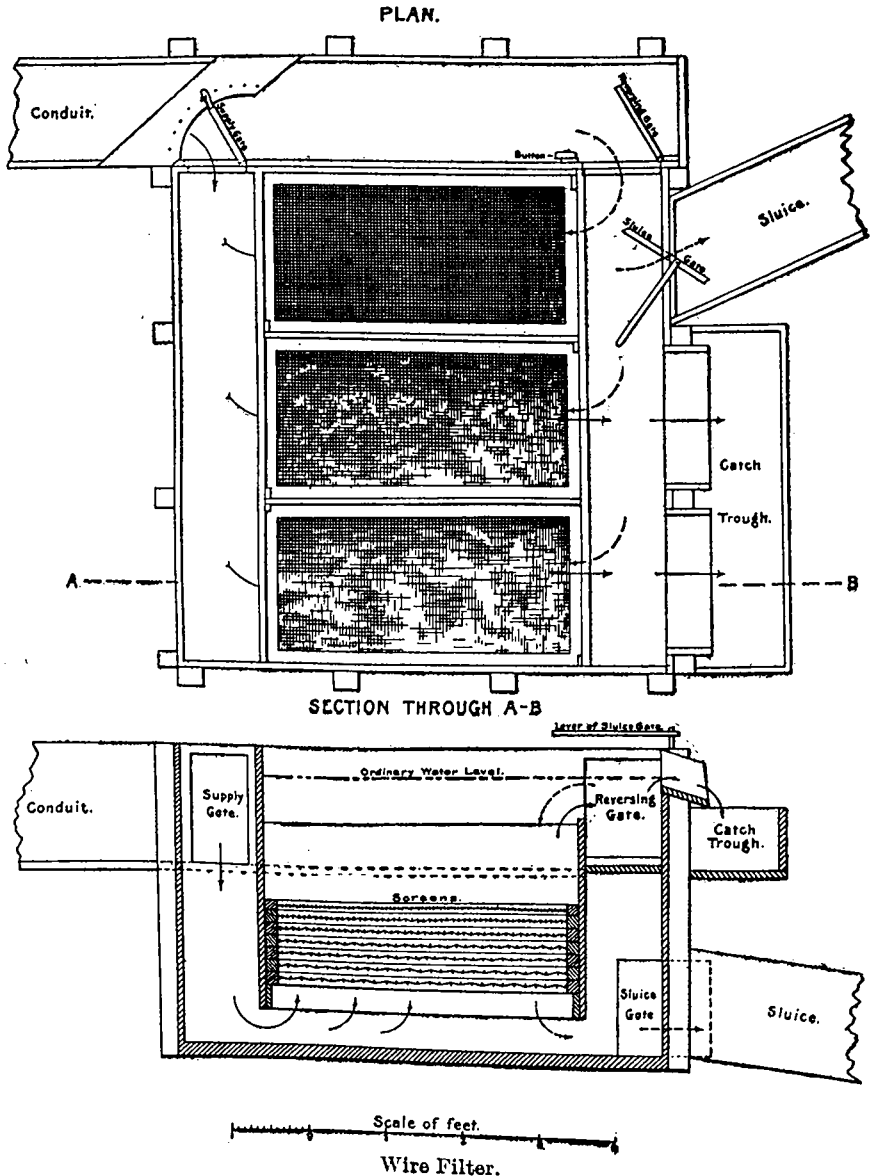

It is but the work of a few moments to reverse the current and thoroughly cleanse the screens; when the autumn leaves are falling this must be done several times a day, but at other seasons some days



SALMON REARING-TROUGHS, WITH RESIDENCE AND BARRACKS IN BACKGROUND, CRAIG BROOK STATION, MAINE.

elapse between the cleanings. The wire—even galvanized—rusts out in two or three years, and lately the coarser screens have been made of slender rods of oak, which will undoubtedly prove more durable.

None of the filters described will intercept the finest sediment, and the water is finally passed through a capacious wooden reservoir, 30 feet long, 8 feet wide, and $5\frac{1}{2}$ feet deep, before it reaches the troughs. This answers the purpose well for the amount of water supplied by the filter last described (about 500 gallons per minute) and is regarded as well worth having, though even this will not insure limpidity in the water when the brook is swollen by rains.

It may be mentioned that this reservoir is kept brimful at all times, so that all portions of the woodwork, except the railing surrounding it, are kept continuously wet and thus insured against decay for a very long period of years.

CRAIG BROOK HATCHERY AND ITS EQUIPMENT.

The Craig Brook hatchery derives its water supply from the brook, which has its source in Craig Pond, but which receives in the lower part of its course many copious springs. This spring water has some advantages, but possesses the serious disadvantage of such high temperature in winter as to unduly hasten the development of the eggs, causing them to hatch early and necessitating shipments of eggs in December.

Accordingly, an aqueduct from a point on the brook above the springs brings to the hatchery a supply of cold water for winter use, in which eggs taken the first of November will not hatch until the following April. This is important, as, if the product of the season's hatching is to be liberated as fry, the late date of hatching will bring them to the feeding stage about the time when suitable food abounds in open waters, and if they are to be reared it is well to shorten up the sac stage and to have the early feeding stage fall at a date when the temperature of the water is rapidly rising, which will get the fish quickly through that most difficult of all stages of growth.

The aqueduct is about 1,600 feet long, with a bore $4\frac{1}{2}$ inches, and has a nearly uniform descent and total freedom from depressions, and is from end to end one single piece of cement concrete. It delivers to the hatchery about 100 gallons of water per minute, which is sufficient for the development of 4,000,000 eggs, and possibly many more. It was built in place around a slightly tapering core, which was drawn forward as fast as the mortar set, and it has now done good service for seventeen years. By this means the temperature of the hatchery water is maintained 3° below that of the brook modified by the springs. During the five months from November 1, 1895, to April 1, 1896, the mean temperature in the hatchery was 36.65° F.

THE EGG HARVEST.

The natural deposit of spawn by the Atlantic salmon in the rivers of the United States occurs during the months of October and November. In artificial operations at Dead Brook it has rarely been necessary to begin spawning before October 22, or to close later than November 15.*

Dead Brook is commonly at a very low stage in August and September, but it rarely fails that before October 20 there is a very material increase in volume. Whenever a sudden rise occurs, even in August or September, imprisoned salmon are at once excited to activity, and any aperture in the upper barrier sufficient to admit the body of a salmon is sure to lead to loss. As the breeding season approaches the sensitiveness of the fish to such influences increases, and a rise about October 20 is followed by a general movement of the salmon upstream in search of spawning-grounds. Advantage is taken of this circumstance to entrap them at the upper barrier, where a small pound with a board floor and a barbed entrance, like that of a weir, is constructed a few days in advance. The success of this trap depends on the stage of the water, and it is always the case that a portion of the fish fail to enter it, so that the final resort is to a seine, with which the recalcitrant salmon are swept out of pools where they are wont to lie.

The fish are dipped from the trap or from the seine with soft bag-nets, such as are used in collecting them at the beginning of the season, assorted according to sex and condition, to facilitate manipulation, and placed in floating wooden pens, which are moored to the bank in front of the spawn-house. These pens are about 12 feet long and 4 feet wide, with grated sides and floors, affording sufficient circulation of water, and, although indispensable for the convenient manipulation of the fish, the confinement in such narrow quarters leads to considerable chafing of noses and tails, and if long continued affects the development of the sexual functions of the female unfavorably, retarding the maturity of the eggs and even affecting their quality. The capture of the fish from the brook is therefore delayed to the point of risking the deposit of some of the earliest eggs in the brook rather than the possible injuries in the pens.

The spawn-taking operations begin as soon as any females are ready to yield their eggs. A scarcity of males in breeding condition has never yet occurred at this station at the beginning of the season, and hardly ever at its close. Among the earliest captures there are always a few unripe fish, but invariably by the last day of October all are ripe.

The spawning-house consists of a single, plain room, with two doors. From one of the beams hangs a steelyard and a bag, in which salmon are weighed. At one end is a stove, in which a fire is built in very cold weather. At the other end is a graduated board, upon which the

* In Canadian rivers the dates are but a little earlier. Thus at the Gaspé hatchery, in the Province of Quebec, in 1894, the work of spawning began October 10 and closed November 2.

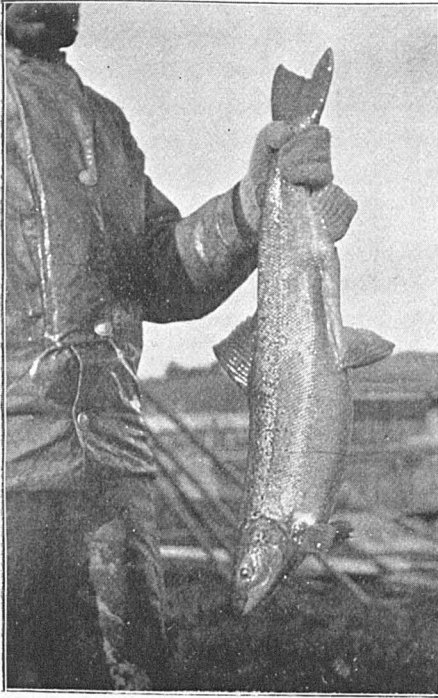

Ripe fish.



Not ripe.

EXAMINING FISH FOR STRIPPING.

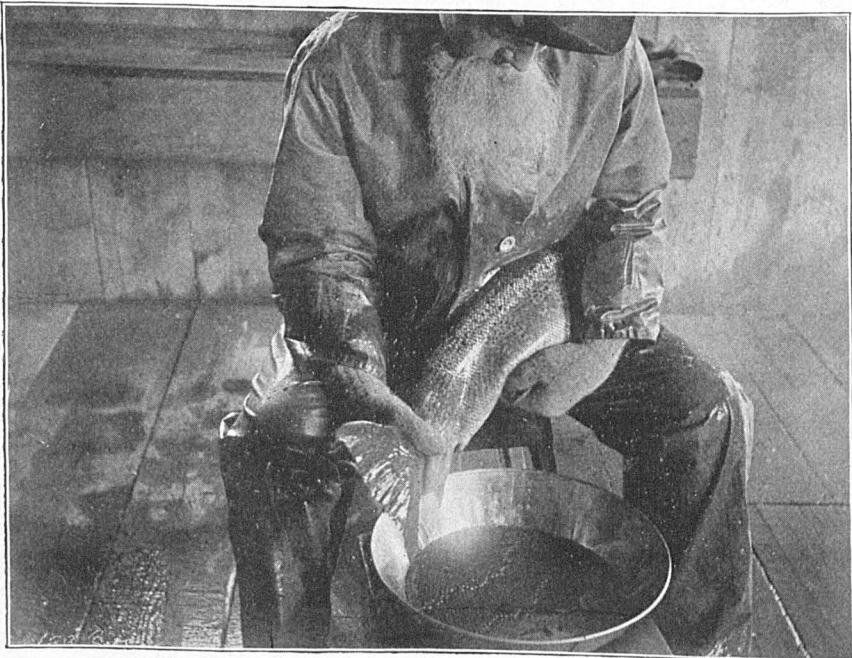

STRIPPING FEMALE SALMON.

fish are laid for measurement. At the front is a narrow table, on which the eggs are washed; and at the rear the entire side of the room is occupied by a series of shelves, on which the eggs are placed after fecundation and washing.

The spawn-taker, clad in waterproof clothing and wearing woolen mittens, sits on a stool or box, and on a box in front of him is a clean tin pan holding about 10 quarts, which has been rinsed and emptied but not wiped out. A female salmon is dipped up from one of the floating pens and brought to the operator, who seizes her by the tail with the right hand and holds her up, head downward. If unripe, the fish is returned to the pens; if ripe, the spawn will be loose and soft and will run down toward the head, leaving the region of the vent loose and flabby, and the operator, retaining his hold of the tail with his right hand, places the head of the fish under his left arm with the back uppermost, the head highest, and the vent immediately over the pan. At first the fish generally struggles violently and no spawn will flow; but as soon as she yields the eggs flow in a continuous stream, rattling sometimes with great force against the bottom of the pan. Shortly the flow slackens and must be encouraged and forced by pressing and stroking the abdomen with the left hand. It is better to use the face of the palm or the edge of the hand rather than pinch between the thumb and finger; the latter action, especially when working down near the vent, is apt to rupture some of the minor blood vessels, with the result of internal bleeding, and it is better to leave some of the eggs behind to be taken another day than to run the risk of such ruptures.

If the fish in hand is fully ripe, nine-tenths of the eggs are obtained at the first trial. When the operation has apparently gone far enough for the first day, the fish is laid in the weighing bag, and as soon as the weight is recorded is stretched upon the measuring board, whence she is returned to the water, after a stay of 10 or 15 minutes in the air, which results in no permanent injury. Both the weight and length of the fish and the weight of the eggs are recorded, together with anything remarkable connected with fish or eggs.

Large salmon endure transportation and confinement less successfully than smaller ones, and the record therefore shows large numbers of salmon from 29 to 31 inches in length, weighing, including eggs, from 9 to 12 pounds, and yielding $2\frac{1}{2}$ to 3 pounds of spawn (6,000 to 8,700 eggs), with now and then a fish 35 or 40 inches in length, yielding, in some cases, as many as 16,000 to 20,000 eggs.

As soon as the spawn of a single female is taken, a male is brought to the spawn-taker and the milt expressed upon the eggs. The pan is then swayed and shaken violently until the milt becomes well distributed and in contact with every egg. If the quantity of spawn exceeds 3 pounds it is divided and fecundated in two pans instead of one, as it is difficult to secure a good result if the eggs lie in too great

masses. The eggs are passed over to the washer, who repeats the swaying and the shaking, and, having weighed them, pours in a small quantity of water and goes through the mixing process for a third time. After this the eggs are immediately washed by pouring in an abundance of water and turning it off, and repeating the operation until the water appears quite clear, when the eggs are placed on the shelves in the rear of the apartment, to await the process of swelling. When the egg first comes from the fish it has a soft and velvety feeling to the hand, and the outer shell lies loose and slack against the yolk. The presence of water excites the shell to action; its pores absorb water with such force that any foreign object coming in contact is sucked against it, and in consequence of this suction the eggs stick to the pan and to each other. In the course of 20 or 30 minutes this process is completed, the shell is swollen to its utmost extent and is firm to the touch, the space between the shell and the yolk is now filled with water, and adhesion to outer objects ceases.

The eggs can now be laid upon trays and carried to the hatchery. No serious harm would ensue if the eggs should be disturbed during the process of swelling, but it is better not to spread them upon trays until they have attained full size and ceased to adhere to each other, and they are left on the shelves until the spawning for the day is over, when all are carried to the hatchery together. After the absorption of water the eggs must be handled very gently, as they are now susceptible to injury from sudden shocks, such as might ensue from pouring them from pan to pan, or setting the pan containing them down roughly upon a wooden table, and to guard against such injuries the tables and shelves are covered with old nets or other soft material.

CONDITIONS AFFECTING FECUNDATION OF EGGS.

While the spawn of a salmon is, with very rare exceptions, in normal and healthy condition and capable of fecundation within the limits of the spawning season, occasionally a fish is found whose eggs are in some way defective. Sometimes they are developed unevenly, the ovaries containing eggs in various stages of growth, some mature and some rudimentary; sometimes all the eggs of a fish are abnormally small, and sometimes all have defects which render them incapable of fecundation. But among the thousands that have been manipulated at the station not 1 in 300 has had defects involving as many as 20 per cent of her eggs, and in the spawn deemed of normal quality there can hardly be more than 1 defective egg in 400. Among the males no instance has occurred where there was reason to suspect the milt of being of defective quality if secured from a living fish.

In 1872 experiments were made bearing on the duration of the capacity for fecundation of the eggs with interesting results. From eight lots of eggs taken from dead fish, the rates of impregnation ranged from 92½ per cent down to zero. From a fish that had been dead 2

hours 4,400 eggs were obtained, of which only 58½ per cent were capable of fecundation. In one instance eggs taken from a dead fish and kept until the morrow before milting remained so far in normal condition that 12½ per cent were fecundated. In another case 400 eggs from a fish that had been dead 15 hours failed totally; and the same result was obtained with 2,200 eggs taken from four specimens killed two days before.

The same experiments afford evidence as to the result of keeping eggs for various periods of time after they are taken from the fish, and eggs exposed to the air and guarded against contact with water appear to keep better than in the organs of a dead fish. Thus, 200 eggs were kept in a pan without water for 12 hours after they were taken from the fish, and the application of milt then resulted in the impregnation of 90 per cent; of 200 eggs kept in the same way for 30 hours and then treated with fresh milt, 87½ per cent were impregnated; and of 100 eggs kept 4 days and then treated with fresh milt, 12 were impregnated.

Milt taken from a living male and kept in an open dish for several hours retains its powers fully, but experiments with milt from dead fish have given almost wholly negative results. Numerous experiments show that if eggs are merely covered by water, without effort to secure intermixture or the washing off of the mucus that envelops them when pressed from the organs of the mother fish, their susceptibility to fecundation may not be seriously affected by immersion 5 or 6 minutes; but if the eggs are stirred, so as to facilitate the washing off of the mucus and the access of pure water, immersion for 1 or 2 minutes may prevent impregnation.

When thoroughly diluted with water the milt speedily loses its power, the effect being very marked at the end of 30 seconds; diluted with the mucus that accompanies the egg, it will remain effective for a long period. Where water has been carefully excluded, milt has been used successfully after the lapse of 12 hours with landlocked salmon, and this would probably hold with eggs of all kinds of salmon and trout. This property of the mixed mucus and milt has been utilized in impregnating masses of eggs when there is a scarcity of males, as sometimes occurs toward the close of the spawning season. In straining the mixed mucus and milt from the pan of eggs, the lower strata, which are richer in milt than the upper, should be especially secured and the mixture kept in a convenient receptacle. The upper strata of the mixture should not be used, as the milt settles to the bottom. Fresh milt should always be preferred when obtainable.

The eggs are washed as soon as the milt is thoroughly diffused among them, and this can hardly be done too speedily for the milt to act. A careful record of certain lots of eggs that were washed in special haste for experimental purposes shows that they were as well impregnated as those exposed to the action of the milt for a considerable period. Prolonged exposure to the milt has been found to affect the health and development of the embryo unfavorably.

TRANSFER OF EGGS TO THE HATCHERY AND THEIR CARE.

From Dead Brook the eggs are transferred to the hatchery at Craig Brook station, about 2 miles, and spread on trays in the spawning-house. The trays are placed in frames, inclosed in boxes which are padded within to guard against concussion. In spite of all precautions some of the eggs are occasionally killed, though the trays are placed in pans of water and the eggs poured from the spawning-pans with the greatest care. The frames or "stacks" containing the eggs are placed at once in the troughs where they are to be developed.

The trays are $12\frac{1}{4}$ inches square, and constructed by attaching iron wire-cloth to light wooden rims with blocks at the corners, so that when piled up, one above another, there are narrow interstices on all four sides, through which water circulates freely. The rims of the trays are very slender, in order that they may never have buoyancy enough to float, which would necessitate some means of holding them down and increase the trouble attending their manipulation. Southern poplar (whitewood) is commonly used, and a rim $\frac{1}{2}$ inch wide and $\frac{3}{8}$ inch deep answers the purpose well, provided the wire be not very light. The corner pieces are $\frac{1}{4}$ inch thick, and give the interstices just enough width to provide an ample circulation of water, but not enough to allow the escape of salmon eggs, which are nearly $\frac{1}{4}$ inch in diameter. Rusting is prevented by varnishing the wire-cloth with several coats of asphaltum varnish, which works better if made very thin by the use of a large proportion of spirits of turpentine. The same varnish gives a clean and glossy surface to submerged woodwork, and the varnishing is extended to the rims of the trays, the "stack-pans," and the interior surfaces of the troughs themselves. Material subject to rust should be used only with great caution. Wire or other metallic forms galvanized with zinc vary in quality. Total loss of eggs has been known to result from the use of galvanized wire-cloth when unvarnished. Careful experiment should precede the use of any particular brand. Tinned wire cloth is better, but whether enough so to warrant the extra expense is a question.

In developing eggs, in order to economize room, the trays are piled up 10 or 20 deep in frames that confine them only at the corners and do not hinder the free passage of water horizontally through the "stack." About 2,000 Atlantic salmon eggs are placed on a single tray, and a trough of the ordinary length, $10\frac{1}{2}$ feet, therefore carries 140,000 to 280,000 eggs, with suitable free space at either end. It is therefore an exceedingly compact apparatus and has the further advantage that it can be used in a very plain trough which can, with a few minutes' work, be transformed into a rearing-trough for young fish. For 10-tray stacks the trough is made of pine boards, $12\frac{3}{4}$ inches wide and 9 inches deep inside, and is set up level, with the top about 30 inches from the floor of the room.

The water is fed into one end through a wooden or rubber tube guarded by a wire screen, and is regulated by a simple swinging gate. The outlet is either over a wooden dam or through a hollow plug, either of which determines the height of the water in the trough, which is always maintained just at the top of the covering tray or an eighth of an inch above it.

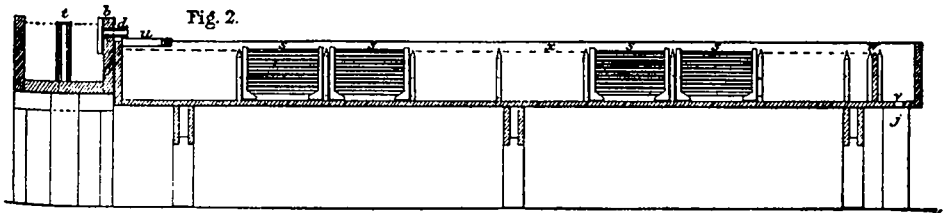
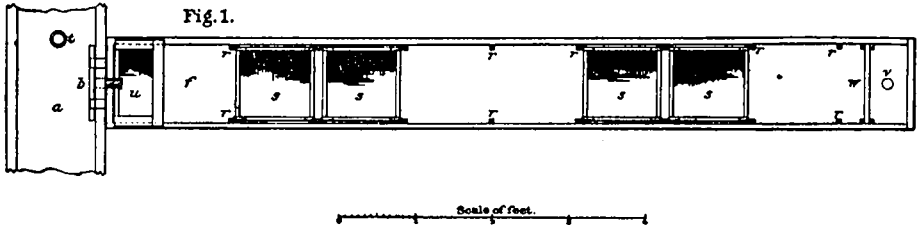

Trough Arranged for Eggs.

Fig. 1, plan. Fig. 2, longitudinal section.

- | | | |
|-------------------|-------------------------|-------------------|
| a, supply-trough. | j, down-spout. | u, screen. |
| b, screen. | r, cleats. | v, outlet. |
| d, supply-pipe. | s, stacks of egg-trays. | w, wooden dam. |
| f, egg-trough. | t, waste-pipe. | z, water surface. |

For the regular picking and cleaning, and for other examinations, the stacks are removed from the trough to a table, where the trays can be taken out one by one, set over into an empty frame, and returned to the trough. This can be performed with ordinary caution at any stage of the development of the embryo, without doing the slightest injury, and after the delicate stage is passed the trays and their burden of eggs can be washed at the same time in a pan of water.

WINTER CARE OF EGGS.

The eggs pass the winter in the stacks. They are regularly picked over and the dead ones removed once or twice a week—twice during the first few weeks, on account of the comparatively high temperature then prevailing and the consequent rapid development of decay and growth of fungus. It depends, to a considerable extent, on the water temperature; the water at the beginning of the spawning season varies from 50° to 55° F., and maintains a mean of 43° to 45° F. during the month of November.

The color of a good egg, or of an unimpregnated egg that still retains its vitality, is a translucent salmon pink, with some variations in shade.

It is possible, by placing it in a favorable light, to get a fairly good interior view, including the detailed anatomy of the embryo. When the egg dies it turns chalky white, becomes wholly opaque, and in a few days, depending on the temperature, decay sets in, and sometimes a white water-mold or fungus begins to grow upon it. The mere decay of the egg would foul the water, thereby injuring the neighboring eggs, and the fungus established on the dead eggs may spread to the living ones. It is therefore essential that the white eggs be removed before they have time to do any injury.

For egg-picking a homemade pair of tweezers, about 6 inches long, is used, made of any convenient wood and tipped with a pair of wire loops of a size to conveniently grasp the egg. The operator lifts the stack of trays carefully from the trough and, to save dripping, carries it on a wooden waiter to a well-lighted table of convenient height, on which stands an oblong pan, 14 by 18 inches, holding about an inch of water.

The stack of eggs to be picked is placed at one end of the pan and at the other end is an empty stack-frame. The trays are examined one by one, dipped in the pan of water, picked (or cleaned by agitation when the eggs are in condition to endure the disturbance), and placed in the empty frame. The air of the room is kept at a low temperature during this process, and the water in the pan is often changed.

The eggs when first impregnated are very sensitive to rude shocks and are handled with great care. Within a few hours the germ begins to develop; in 10 days, at a temperature of about 40° F., the germ-disk appears as a ring of color on the upper side of the yolk. At this date the unimpregnated egg presents the same appearance and does not change much until its death, however long that may be deferred. In the impregnated egg, however, the germ-disk continually enlarges upon the surface of the yolk; the ring of color that marks its edge advances before it, passing quite round the yolk, and closing up on the posterior side.

As early as the thirteenth day the difference between the impregnated and unimpregnated egg is quite plain to the unaided eye after a very little experience, and three or four days later the good egg is marked by a distinct line of color passing around the very middle of the yolk, a phenomenon never appearing in an unimpregnated egg. During this stage, while the embryonic disk is spreading around the yolk, the egg grows constantly more and more delicate, and liable to rupture of its tissues and consequent death on very slight disturbance; but later the tissues grow stronger, and when, about the thirty-fifth or fortieth day, the eyes of the embryo have assumed enough color to appear as two dark dots, the egg has attained hardness enough to endure rougher handling. Thenceforward, until the near approach of the time for hatching, the work consists simply in picking out the dead ones, occasionally rinsing out the sediment, and sometimes removing the unimpregnated eggs.



PICKING OUT DEAD EGGS.

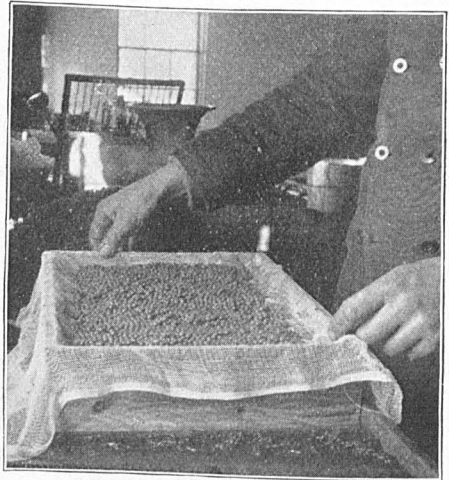

PACKING SALMON EGGS.

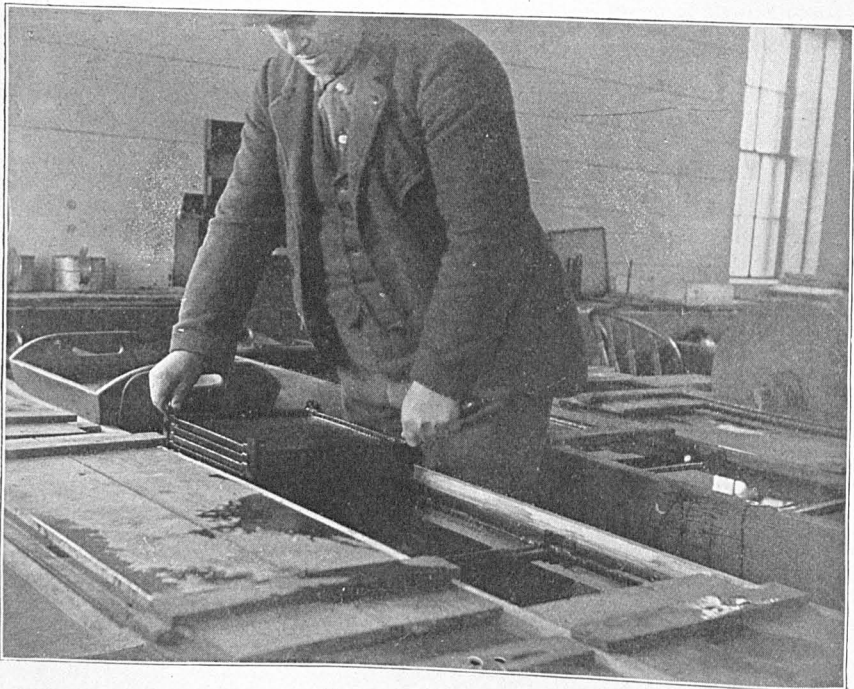

HANDLING EGG-TRAYS.

The latter procedure is attended to for the entire stock of eggs, but is of special importance in case of those that are to be transported. It may be performed any time after the good eggs become hardy—that is, after the eyes become black—but becomes easier late in the season. The unimpregnated eggs, which were at first fully equal in hardness to the impregnated, lose in that respect as time passes, and finally are readily killed and turned white by a shock which does no injury to the impregnated eggs. When this time has arrived, the eggs are turned from the trays into spawning-pans with a moderate quantity of water, and poured from pan to pan back and forth a dozen times, each time falling a foot or more, and striking the bottom of the pan with considerable force, giving each egg a severe shock. They are then returned to the trays and troughs and as soon as convenient are picked, and if the operation has been thorough almost every unimpregnated egg has turned white and is picked out, while the eggs in which the embryos are developing have not suffered at all.

PACKING AND TRANSPORTING.

Eggs may be safely transported as soon as the eyes have become thoroughly colored, and until within a few weeks (five or six in cold weather) of the date for hatching. In shipments made too late the shells burst on the way and the embryos perish. The method of packing eggs at Craig Brook is to put them in layers alternating with wet sphagnum moss in shallow wooden boxes, placed in cases of a size to afford on all sides of the inner package a space of $2\frac{1}{2}$ or 3 inches, which is filled with some light, porous material that will form a good nonconductor of heat.

The eggs are thrown from hatching-trays into a large rectangular pan, from which they are poured with water into tin measures which hold 2,500 each. A thin layer of moss is placed in the bottom of a packing-box. A little fine snow is sifted upon the moss, and on this is spread a piece of mosquito netting that has been soaked and rinsed in clean water. A measure of eggs is now poured on and spread out and covered by folding over the edges of the netting, which now completely envelops them. Next a layer of moss is spread, followed by snow, netting, and eggs, as before, and the series is repeated until the box is full. The moss must be sufficiently wet, so that with the melting of the snow it shall have all the moisture it will hold, and no more, as it is very desirable to avoid the wetting of the outer packing. If the moss is too dry, the eggs may dry to the extent of becoming indented, and the same result may come from crowding the moss in too hard on the eggs, though it should be pressed in so tightly that the eggs will not slide out of place if the case is turned for a moment on its side.

The temperature of the packing-room is below 50° F., and packing materials are kept in a place which is cool, yet not much below the freezing-point. Salmon eggs packed as above commonly go a three days' journey without completely melting the snow that was sprinkled

under the eggs, and on several occasions eggs of landlocked salmon have been carried across the Atlantic in prime condition, without repacking or special attention.

The packing-boxes are made of thin pine or fir, 12 inches wide and 15 inches long— $\frac{3}{4}$ -inch thick boards being used for the end pieces and $\frac{1}{2}$ -inch for the other parts—and hold in a single layer, without crowding, 2,500 eggs. The deepest are $3\frac{1}{2}$ inches deep and take four layers, or 10,000 eggs, in a box. To make up a shipment of 40,000 eggs, four boxes are piled up and secured together by tacking strips of wood against the ends, with a cover on the upper box, and this package placed in the case. For a shipment of 80,000, two of the 40,000 packages are put side by side in a larger case, and the proportions selected for the inner boxes are such that the case required is of convenient form.

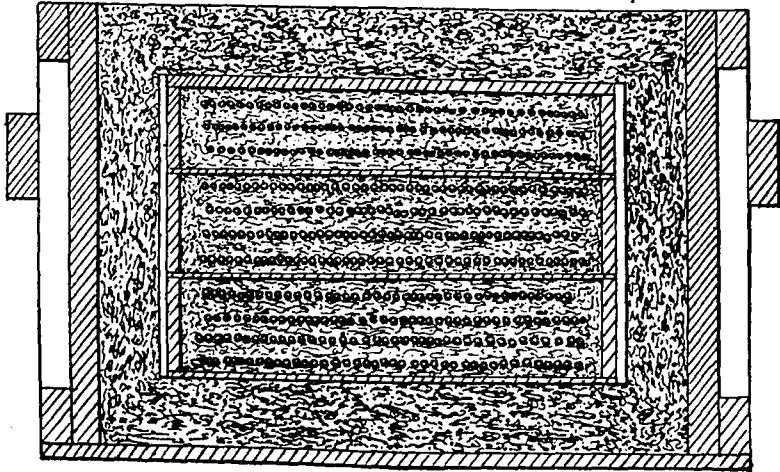

Longitudinal section of a case of Atlantic Salmon eggs.

Different mosses can be used for packing, but none are so good as the sphagnum moss that can be found in swamps and bogs in most regions of high latitude or considerable elevation. Fresh moss is preferable for a bed for the eggs, though dead, dry moss may be moistened and used with good results.

The moss is gathered in August or September, dried on the ground, and stored in sacks or in bulk until wanted. It retains its freshness through the following winter, not heating like most organic materials. It is exceedingly light, and the best nonconductor known, with the possible exception of asbestos. It is used dry in the outer packing, mainly to save weight, but when protection against freezing is all that is sought, wet moss is better, as frost penetrates wet moss more slowly than dry. When moss can not be had, there are many substitutes which may be used for the protective envelope, such as dry forest leaves, chaff from a haymow, chopped hay, or even crumpled paper; but the latter should not be allowed to become wet.

HATCHING.

As the time for hatching draws near, the eggs are placed on trays provided with legs or some other support to keep them up from the bottom of the trough. Brass nails driven into the under sides of the tray rims are good temporary legs, and after the hatching is over they are readily removed and the necessity of a special set of trays for hatching is avoided. When there are plenty of troughs, these trays stand singly on the bottom of the trough, but when it is necessary to economize room two or even three are disposed one above another. When no necessity exists for economy of space, 4,000 eggs are allowed a whole trough, which is at the rate of 400 to the square foot; 2,000 or even 5,000 to the square foot may be carried through hatching and the entire sac stage, but the latter number involves risky crowding.

The hatching is sometimes expedited by giving eggs that are just at the hatching point a decided shock, similar to that given at an earlier date to kill the unimpregnated ones; also by the temporary stoppage of the water supply. But at Craig Brook it is the custom to lay the eggs out in good season and allow them unlimited time in which to hatch, sometimes a week, sometimes two weeks. The earliest lots commonly hatch the latter part of March, and it is not often that any remain unhatched after April 20. The mean duration of the egg stage is therefore about 157 days, during which the mean temperature of the water has been about 37° F. While hatching is progressing, the outlet screens are closely watched to keep the empty shells from clogging them up; for when a considerable part of the screen is clogged the force of the current through the open spaces is greatly increased, and the soft and yielding sacs of the fish are liable to be drawn through the meshes.

THE SAC STAGE.

When the shell breaks, though it has been coiled up in a space less than $\frac{1}{4}$ inch in diameter, the trunk of the newly hatched salmon at once straightens out to a length of about $\frac{3}{4}$ inch. The yolk, scarcely diminished from its original size, hangs beneath and constitutes the greater part of the bulk of the fish. The young salmon is for a while more unwieldy than a tadpole. When frightened he sculls about with great energy, but makes slow progress and is fain to lie on his side on the bottom of the trough or crowd with his companions into a corner. The sac is a store of nutriment, which is gradually absorbed into the other parts of the fish; and so long as it lasts the young salmon will not eat. The interval between hatching and total absorption of the sac varies with the temperature, the mean at Craig Brook in April and May being about six weeks.

As time passes the embryo fish grows more and more to resemble the adult, his body acquires strength, and his fins assume form and become more effective as organs of propulsion. At last his digestive system

assumes its functions and rouses the desire for food. Until this time, intent only on hiding, the fry have clung obstinately to the bottom and to the dark corners, but now they scatter about through the water, with heads upstream watching for prey. This indicates that they must be fed. During this period of his growth it is simply necessary to see that the young fish has plenty of water, that there is no hole or crevice into which he can be drawn by the current, and that he is protected from enemies, such as large fishes, minks, rats, kingfishers, and herons. If not in a house, well-fitting covers must be provided to the troughs and impassable screens command both ends. The screens are of fine wire-cloth, 12 or 14 meshes to the linear inch, and present a surface of 14 square inches to each gallon of water passing through them each minute. Thus, if there are 4 gallons of water passing through the trough each minute the portion of the screen beneath the surface of the water must measure as much as 56 square inches, and if the screen is 12 inches wide the water must be $4\frac{2}{3}$ inches deep on the screen.

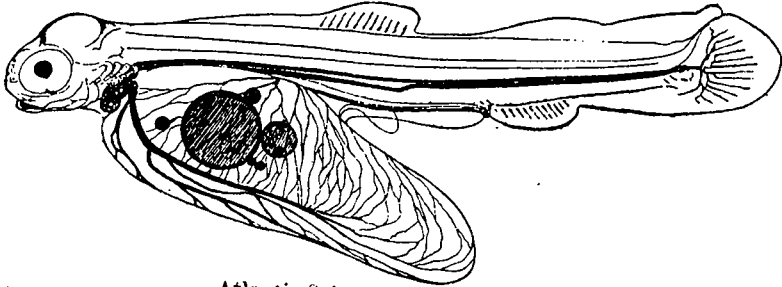

Atlantic Salmon, recently hatched.

REARING.

The leading feature of the work of the station is the rearing of fry to the age of six or eight months. The fishes reared are mainly Atlantic salmon, but landlocked salmon, American brook trout, European brook trout, rainbow trout, steelhead trout, American lake trout, Swiss lake trout, Scotch sea trout, and saibling have also been handled. The fish are fed wholly on artificial food from about June 1 till October or November, when they are mostly liberated. To a limited extent they are kept in artificial ponds, but troughs of the same form and dimensions as those already described for use in developing the eggs and in hatching have given satisfactory results and have been adopted for the most part. Each trough is provided with a changeable outlet screen and below the screen discharges the water through a hole in the bottom, into which is fitted a hollow plug, the height of which determines the depth of water in the trough. The hollow plug plays an important part in the daily cleaning of the trough, which will be referred to further on.

The use of the troughs in the open air, which, in the absence of commodious buildings, is a necessity, compels the constant use of covers to keep out vermin; and wooden covers in pairs, running the whole length

of the trough, hinged to its sides, and, when closed, assuming the form of a roof at an angle of 45°, were finally adopted. These covers are made of thin boards, $\frac{5}{8}$ inch thick, sawed in narrow pieces, which are put together so as to leave in each corner two cracks open $\frac{1}{4}$ inch wide for the admission of light when the covers are closed. When open they may be fixed in an upright position, thus increasing the height of the sides and guarding against the loss of fish by jumping out.

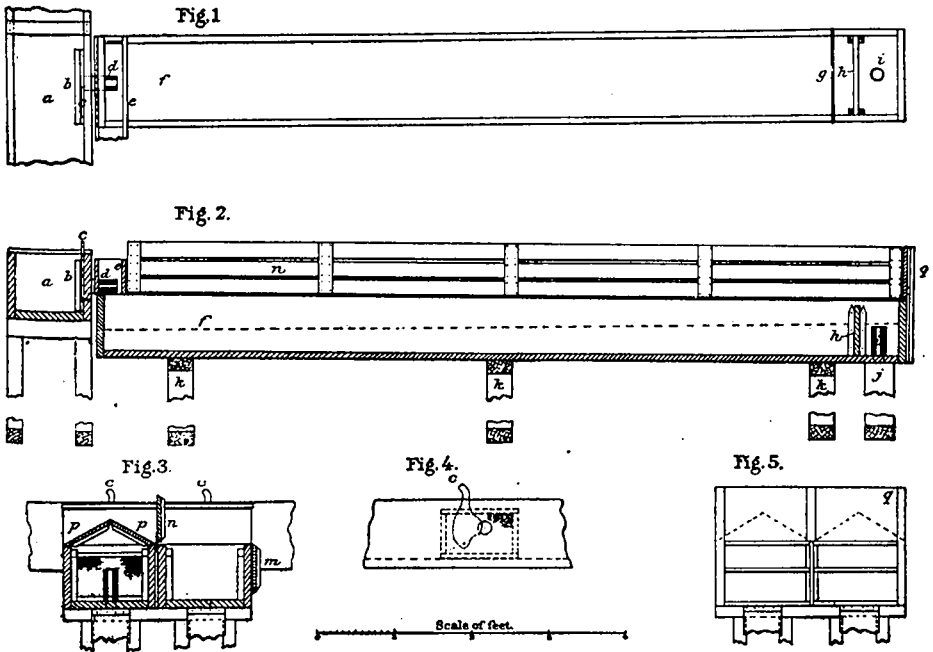

Troughs arranged for Rearing.

Fig. 1, plan. Fig. 2, longitudinal section. Fig. 3, cross-section near foot of trough. Fig. 4, inlet, with rocking gate. Fig. 5, elevation of lower end.

- | | |
|---|--|
| <ul style="list-style-type: none"> a, supply-trough. b, screen. c, rocking gate. d, supply-pipe. e, water-board (to spread the water and throw it down). f, fish-trough. g, gripe, to prevent spreading of sides. h, outlet screen. | <ul style="list-style-type: none"> i, hollow outlet plug. j, down-spout. k, supports. l, cover. m, cover open (hanging). n, cover open (upright). p, cover closed. q, end boards (closing aperture). |
|---|--|

Water is furnished through rubber or wooden pipes $\frac{3}{4}$ inch in diameter, and the bore of the hollow plug at the outlet is $1\frac{1}{4}$ inch or larger. The inflow is regulated by an oscillating or rocking gate, which is set to admit the desired volume of water. The trough is set with the upper end an inch or two higher than the other, to facilitate cleaning out, and the water is kept during the summer about 4 inches deep at the lower end.

The troughs are supported by a suitable framework at a convenient height from the ground and arranged in pairs with their heads against a long feed-trough, constructed of pine boards and perforated on the side by the feed-pipes, over each of which is a capacious screen to prevent clogging by leaves or other floating debris. A frame 6 by 12 inches, covered on its outer side by wire-cloth of $\frac{1}{4}$ inch square mesh, answers the purpose of a screen so well that water from an ordinary brook can be admitted to the feed-trough without previous filtering or screening and with little or no danger of a stoppage of water in any of the fish-troughs. Such screens over the feed-pipes might be made the sole dependence, were it not that the labor attending their cleaning would be greater than that required by a separate filter or screen.

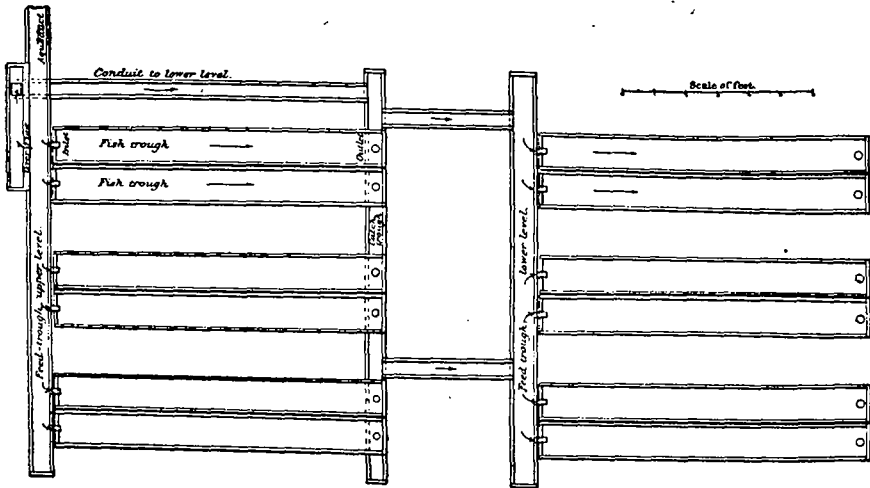

Stand of Troughs for Rearing Atlantic Salmon.

The system represented here by 12 troughs in two series may be extended to many hundreds of troughs in four (or more) series, each series on a different level and receiving water from the series next above, the fall from one to another being about 4 feet. In the drawing the series of 6 troughs on the left is supplied with water directly from the upper "feed-trough" (i. e., supply-trough), and they discharge into a catch-trough, from which the water is carried to the supply-trough ("feed-trough") of the lower level. If the aqueduct supplies more water than the upper series of troughs can use, the surplus passes by way of the "overflow" directly to the catch-trough and thence to the supply-trough of the second series. With a fall of 4 feet, the catch-trough and the conduits that lead from it are below the walks which give access to the troughs on both sides and at the lower end.

The number of fish assigned to a single trough is ordinarily 2,000, and the volume of water given them is commonly 5 gallons per minute. Generally the water is used but once in troughs and is discharged

into conduits leading to ponds where larger fish are kept; but a stand of 100 troughs has lately been set up with the design of using all the water twice; and for many years there has been one system of 52 troughs, arranged in four series, which use in succession the same water, the young salmon thriving quite as well in the fourth series as in the first.

On one occasion a few of them were maintained for several weeks in the warmer water of a neighboring brook, where a trough was set up and stocked with 100 young salmon taken from one of the troughs at the station July 30. The temperatures observed between 1 and 4 p. m. in the fish-trough on successive days from July 30 to August 14, not including August 1 or 10, were as follows: 79°, 75°, 77°, 79°, 82°, 82°, 78°, 76°, 76°, 76°, 74°, 74°, 74°, 74°, F.

The fish were fed the same as the lot out of which they were taken, except that they received food only once a day instead of twice, and were returned to the station October 7 without a single loss during the experiment. Moreover, they were all weighed October 10 and found to average 100.6 grains, while those of the original lot that had remained at the station, with a temperature between 50° and 71° F., averaged only 56.1 grains. While the greatly increased weight of the fish kept in the stream was owing in part to more space, as the 100 had as large a trough as 1,505 at the station, the higher temperature was undoubtedly one of the factors that contributed to the gain in weight, and it is at least plainly shown that the warm water was not unhealthful.

Though small ponds, excavated by the former proprietor, were in existence at the station and used to some extent for rearing young fish in their first summer as far back as 1888, and older fish have been kept in small ponds each season since that, it was not until 1896 that enough pond work was done to furnish data of importance.

The ponds for rearing Atlantic salmon are among the series known as the "south ponds," occupying a smooth piece of ground sloping toward Alamoosook Lake at a grade of 1 in 8. Formerly it was mostly a swale, watered by a copious spring at its head. This series comprises 19 ponds of rectangular form, about 50 to 90 feet long and 15 feet wide, with a depth of 2 or 3 feet. The water supply of those used for Atlantic salmon is derived from Craig Brook by an aqueduct tapping it at a point where two parts of Craig Pond water are mingled with one part spring water, being substantially the same as the water supplying the most of the rearing-troughs. From 5,000 to 10,000 fish that have been fed in troughs during the early part of the feeding season are placed in each pond, and for the remainder of the season are fed the same food that is given to the fish left in the troughs; and the results indicate that the stock of fish might be safely increased.

While the greater part of the salmon reared at Craig Brook are liberated in October, when about seven months old, in 1891-92 about 16,000 were carried through the winter, most of them in tanks sunk in the ground, and nearly as many have been wintered some other

seasons. Fish may also be kept all winter in troughs in the open air by occasionally spreading blankets over them in exceptionally cold weather, and keeping the conduits carefully covered.

The fish surviving the summer season are generally counted and weighed in October, in the following manner: A large number of them are dipped up from a trough in a small dip net made of cheese-cloth, and from this, while it is hanging in the water in such a manner that the fish can not escape, they are dipped out a few at a time, in a small dipper or cup, counted, and placed in another bag net until a sufficient number (generally 200) are counted, when they are lifted out of the water, held a moment in the air to drain, and all turned quickly into a pail of water which has previously been weighed. With care no appreciable amount of water goes with the fish, and the increase in the reading indicates their weight with a fair approach to accuracy, and with care and celerity of action it is quite safe for the fish.

The size attained by the fish varies greatly, being affected by the water, the space allowed, the feed, and perhaps by hereditary influences; but when seven months old a trough-reared salmon is generally from 2½ to 3 inches long and weighs from 35 to 100 grains, the maximum being about 130 grains and the minimum as low as 7 grains, the general mean for 1896 being 45.8 grains. Salmon reared in ponds have been far more thrifty, their general average in 1896 being 101 grains.* The losses in ponds from July to October were rather heavy, being 11.7 per cent, owing to depredations of frogs, birds, and cannibal fish. The losses in the troughs during the entire season were 9.1 per cent, but most of these were in the early stages of fryhood. After July losses in troughs are always very light.

MATERIALS FOR FISH FOOD.

At Craig Brook station there have been used butchers' offal, flesh of horses and other domestic animals, fresh fish, and maggots. Experiments have also been made with pickled fish, blood, fresh-water mussels, mosquito larvæ, miscellaneous aquatic animals of minute size,

*A very interesting comparison between the results of rearing in troughs and ponds is afforded by the record of two lots of steelhead trout during the season of 1896. All the fry of this species that were devoted to rearing were fed in troughs until July 22, when some of them were transferred to a pond which has an area of about 1,100 square feet and another lot was kept in a trough. The two lots were fed exactly alike, about one-sixth of their nutriment being liv maggots, and five-sixths chopped meat, liver, and other butchers' offal. November 7, the lot in the trough was overhauled, and the 762 survivors found to weigh 10 pounds 4 ounces, or an average of 94 grains. Three days later the pond fish were seined out and the 7,398 survivors found to weigh 235 pounds 10 ounces, an average of 223 grains. It is not believed that natural food occurring in the pond contributed much to this result, and it would appear that the controlling factor in the case was the space afforded the fish. Leaving out of the account the difference in depth, in the pond there were less than 7 fish to each square foot of area, while in the trough, which had an area of about 11 square feet, there were to each square foot 69 fish. A similar illustration was furnished by 41 rainbow trout of the hatching of 1896 that got astray in one of the ponds and were taken out November 11, weighing 480 grains each. Those of the same age, reared in troughs, attained during the season only a weight of 136½ grains each.

flour, and middlings. The butchers' offal comprises livers, hearts, and lights, which are collected from the slaughter-houses twice or thrice weekly, and preserved in refrigerators until used.

The flesh of old and worn-out horses has been used each year since 1892 in the same way as the butcher's offal, with very satisfactory results; the parts that could be chopped readily have been fed direct to the fish so far as needed, and other parts have been used in the rearing of maggots.

Next to chopped meat maggots have constituted the most important article of food, and their systematic production has received much attention. A rough wooden building has been erected for this branch of the work, and one man is constantly employed about it during the summer and early autumn months. The maggots thus far used are exclusively flesh-eaters, mainly those of two undetermined species of flies; the first and most important being a small, smooth, shining green or bluish-green fly, occurring in early summer and remaining in somewhat diminished numbers until October; and the other a large, rough, steel-blue fly that comes later and in autumn becomes the predominating species, having such hardiness as to continue the reproduction of its kind long after the occurrence of frosts sufficiently severe to freeze the ground.

To obtain maggots meat is exposed in a sheltered location accessible to flies during the day. When well stocked with the spawn of the flies it is placed in boxes, which are set away in the "fly-house" to develop; when fully grown, the maggots are taken out and fed at once to the fish. Stale meat, parts of the butchers' offal and of the horse carcasses not adapted to chopping; fish, fresh, dried, or pickled; fish pomace from herring-oil works, and any animal refuse that comes to hand, are used to entice the flies and afford nourishment for the maggots. Fresh fish, when not too watery or oily, like alewives and herring, is very attractive to the flies, and in proper condition may serve as well as fresh meat. Fish dried without salt or smoke and moistened before using is, when free from oil, a superior article. Its preparation presents some difficulties, but in winter it is easily effected by impaling whole fishes on sticks and hanging them up under a roof where they will be protected from rain without hindering the circulation of the air; in this way many flounders and other refuse fish from the smelt fisheries have been dried.

It is usually necessary to expose meat but a single day to obtain sufficient fly spawn; the larvæ are hatched and active the next day, except in cool weather, and they attain their full growth in two or three days. To separate them from the remnants of food the meat bearing the fly spawn is placed on a layer of loose hay or straw in a box which has a wire-cloth bottom, and which stands inside a slightly larger box with a tight wooden bottom. When full grown, the maggots work their way down through the hay into the lower box, where they are found nearly free from dirt.

When young salmon or trout first begin to feed they are quite unable to swallow full-grown maggots, and small ones are obtained for them by putting a large quantity of fly spawn with a small quantity of meat, the result being that the maggots soon begin to crowd each other and the surplus is worked off into the lower box before attaining great size. No attempt is, however, made to induce the young fish to swallow even the smallest maggots until they have been fed a while on chopped liver.

Maggots are produced and used in considerable numbers, sometimes as many as a bushel in a day. The fish eat them eagerly, and appear to thrive on them better than on dead meat. Having great tenacity of life, if not snapped up immediately by the fish they remain alive for a day or two, and, as they wriggle about on the bottom, are almost certain to be finally eaten, which is a great gain in cleanliness and economy, as the particles of dead flesh falling to the bottom are largely neglected by the fish and begin to putrefy in a few hours and foul the troughs. As the growth of maggots can be controlled by regulation of the temperature, they may be kept all winter in a pit or cellar and used as food for fish confined in deep tanks not easily cleaned.

In the rearing of maggots the offensive odors of decaying flesh may be partly overcome by putting it away in boxes, after the visits of the flies, and covering it with pulverized earth. Only flesh-eating maggots have yet been tried, and the trouble may possibly be rectified by cultivating the larvæ of other species, such as the house-fly, the stable fly, etc., or a little white maggot known to grow in heaps of seaweed, if their rate of growth is found to be satisfactory.

Occasional use has been made of fresh fish for direct feeding, but when thrown into the water after chopping it breaks up into fibers to such an extent that it is not satisfactory, unless in a coarsely chopped form, for the food of large fish. A few barrels of salted alewives have been used, and, if well soaked out and chopped, they are readily eaten by the larger fish and can be fed to fry, but are less satisfactory with the latter, and, like fresh fish, break up to such an extent that they are only to be regarded as one of the last resorts.

Fresh-water mussels, belonging almost wholly to a species of *Unio*, have been occasionally gathered with nets or dredges in the lake close to the station and opened with knives and chopped. The meat is readily eaten by all fishes and appears to form an excellent diet. It is more buoyant than any other article tried, sinks slower in the water, and gives the fish more time to seize it before it reaches the bottom; but the labor involved in dredging and shelling is a serious drawback.

During the seasons of 1886 and 1888 some use was made of mosquito larvæ, collected from pools of swamp water by means of a set of strainers specially devised for the purpose and from barrels filled with water disposed in convenient places near the rearing-troughs. The larvæ (or pupæ) were strained out and fed to the fish. No kind of food has been

more eagerly devoured, and apparently no other food has contributed more to the growth of the fish; but the time expended in collecting is out of all proportion to the quantity of food secured. Perhaps a series of breeding-tanks arranged in proximity to the fish-troughs, into which the water containing the larvæ might be drawn when desirable by the simple opening of a faucet, would reduce the labor involved.

Middlings and flour have been tried in combination with blood from the shambles, but did not appear to satisfy the fish so well as the various forms of meat, and their use has, therefore, not been continued. They were fed in the form of a pudding composed of two parts blood and one part flour or middlings, cooked carefully to avoid burning, and the mixture was then passed through a meat-chopper and ladled out with a spoon, like other chopped food.

The growth of live food in the ponds themselves in which the fish are maintained has been the subject of study. Ponds several years old and well stocked with vegetation were at one time devoted to these experiments. They had been empty during the preceding winter, and in the spring were fertilized with various sorts of animal and vegetable refuse. They were stocked with different species of crustacea native to the region, including shrimps (*Gammarus*) and entomostraca, of the genera *Daphnia*, *Ceriodaphnia*, *Sida*, *Cyclops*, *Polyphemus*, etc., which were systematically collected from open waters by nets and other apparatus and placed in the ponds. These forms all multiplied there, some of them enormously, but no means was found of inducing continuous or frequent reproduction of them, and the young fish soon exhausted the supply.

In serving the food the attendant carries it with the left hand—in a 2-quart dipper if chopped meat, in a larger vessel if maggots—and, dipping it out with a large spoon, strews it the whole length of the trough, being careful to put the greater portion at the head, where the fish nearly always congregate. Finely chopped food, for very young fish, is slightly thinned with water before feeding.

It is usual to feed the meat raw except the lights, which chop better if boiled first; but occasional lots of meat, on the point of becoming tainted, are boiled to save them. All meats fed directly to the fish are first passed through a chopping-machine. To fish just beginning to eat, food is given four times a day, or in some cases even six times, but as the season progresses the number of rations is gradually reduced to two daily. In winter such fish as are carried through are fed but once a day.

CLEANING THE TROUGHS.

The troughs are all cleaned daily. When the hollow plug is drawn the water rushes out rapidly and carries most of the debris against the screen. The fishes are excited, and, scurrying about, loosen nearly all the dirt from the bottom; what will not otherwise yield is started with a brush, but after the first few weeks the brush has rarely to be used

except to rub the debris through the outlet screen. Owing to the inclination of the trough, the water recedes from the upper end until the fishes lying there are almost wholly out of water, but, although they are left in that position sometimes for 10 or 15 minutes, no harm has ever been known to result.

TRANSPORTATION AND LIBERATION OF YOUNG SALMON.

The salmon produced at the station have, with few exceptions, been liberated in the Penobscot River or its tributaries, and more than 90 per cent of them in small tributaries within 10 miles of the station. They have been spread about in streams and lakes, at all accessible points. They are transferred in tin cans, holding about 8 gallons, with an extreme height, including neck, of 17 or 18 inches, and a body 15½ inches in diameter and 10 inches deep, making a very broad and low can, well adapted to the use to which it is put. Its great width favors aeration at the surface, and a good deal of dashing about of the water when on the road. The cans are filled to within about an inch from the shoulder, giving opportunity for the water to swash about and aerate itself. Into such a can are put from 200 to 400 Atlantic salmon seven months old, more or less, according to the size of the fish, the temperature of the air, and the weather. The ordinary load is about 300 when the temperature of the water is 52° to 54° F., making 37 fish per gallon. Such loads are entirely safe for the conditions attending the work. The motion of the wagon in which they are carried keeps up the aeration of the water, so that the fish can not exhaust the air. Should the cans stand still a very long time aeration is effected by a force-pump which draws the water from the can and returns it through a tube so that it strikes upon a deflector by which it is broken and scattered in spray. The suction hose is covered with a roomy wire strainer, so that the fish are not drawn in.

DISEASES.

Salmon in all their stages of growth are subject to a variety of diseases. White spots sometimes occur on the eggs attached to the shell, but have no hold on the embryos, so that when the shell is torn off the white spot is seen as a cluster of globular white masses on its inner surface. These appear to be vegetable parasites, perhaps fungoid in their relations, and are never seriously abundant. Other white spots are connected with the yolk-sac itself. These are more serious, but while they result in the death of many embryos, they are by no means always fatal. In 1896 there were hatched at the station some rainbow trout that were badly spotted on the sac. A portion of the fry were divided into three lots for experiment: (a) Without spots; (b) moderately spotted; (c) badly spotted. They were kept separate through the season, and a fair percentage survived, as follows: Of lot *a*, 55 per cent; of lot *b*, 59 per cent; of lot *c*, 43 per cent. In the fall they were

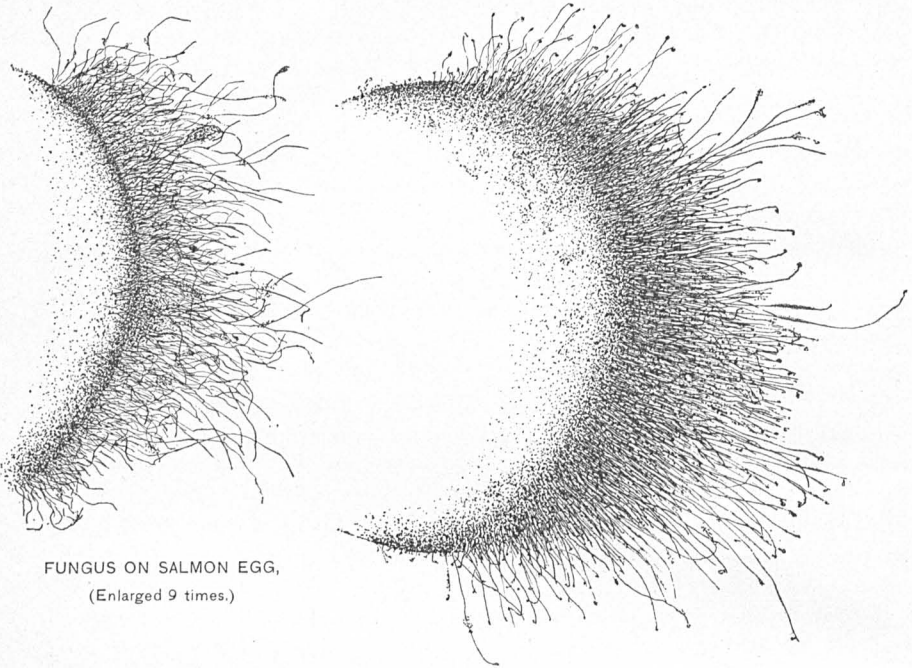

FUNGUS ON SALMON EGG,
(Enlarged 9 times.)

FUNGUS ON SALMON EGG, BEARING REPRODUCTIVE ORGANS.
(Enlarged 9 times.)

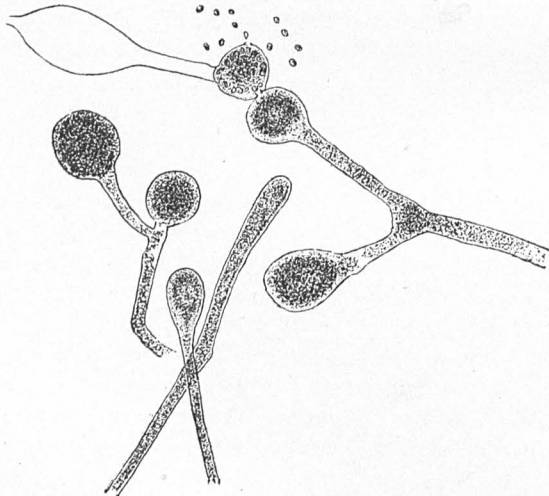

REPRODUCTIVE ORGANS OF EGG FUNGUS.
(Enlarged 150 times.)

all weighed, and it was found that lot *c* had made a slightly better growth than lot *a*.

One of the most uncontrollable diseases attacks salmon fry midway in the sac stage, and finishes its work before the complete absorption of the sac. The most evident symptom is the appearance of scattered white spots in the sac; the fish cease to try to hide, but lie scattered about on the bottom of the trough; the spots increase in size, coalesce, and finally occupy large areas, especially in the tip of the sac, which becomes quite white. Soon after this the fish dies. The attack on a lot makes rapid progress; for instance, a lot of 2,000 in which, up to April 22, the losses have been from 1 to 9 daily, will show 17 dead on the 23d, and five days later 360 die in a single day. In 1890 this epidemic attacked especially the fry of Atlantic salmon, destroying about a third of them; it also destroyed many landlocked salmon, and some other species suffered heavily about the same time. In 1891 there was not a trace of it. In 1892 it returned again, and out of 305,353 fry of Atlantic salmon it left but 3,874, and these were by no means healthy; but it attacked only Atlantic salmon. Salt and mud were tried as remedies, but though the progress of the disease appeared in some instances checked thereby, no permanent benefit resulted from their use.

In 1890 this epidemic appeared to run in families. There was evidence tending to show that all the eggs coming from a particular mother would have a common degree of liability to the disease—some families being exterminated by it, some only decimated, and others able to resist it altogether. It did not appear to be infectious, as several lots of fry, separated by screens, would occupy a single trough, and in some cases those at the head of the trough would be totally destroyed, or nearly so, and those below them escape from attack.

The only other diseases of Atlantic salmon that demand notice here are connected with the so-called fungus, belonging to the group of water molds called *Saprolegnia*, and probably to the genus *Saprolegnia*, one species of which, *S. ferax*, is noted as the cause of very destructive epidemics among the adult salmon of Scotch and English rivers. The species that attacks fish eggs is well known to every fish-culturist as a fine white growth of a cottony or woolly appearance that forms upon dead eggs, and when neglected spreads out so as to envelop in its threads a great many of the living eggs surrounding it. It is by no means certain that all such growths belong to one species or even to one genus, but they are much alike in structure and growth and live upon animal and vegetable matter, either as parasites attacking living matter or as saprophytes attacking only dead and decaying matter. There has never been serious trouble with this fungus at Craig Brook station, and great loss from it can only occur in consequence of neglect of the duty of picking out the dead eggs. An instance of its attacking a living egg except by reaching out from a dead one is unknown. Fish

several months old are sometimes afflicted with a similar growth, which may possibly be not the original cause of the disease, but only an attendant symptom. Such an attack was experienced at Craig Brook in July, 1888. The fry of Atlantic salmon were the sufferers and the mortality was considerable, but it yielded promptly to a salt bath.

The occurrence of fungus on wounds, even on such as result from the abrasion of the skin or the loss of a scale, is very common, but such cases are rarely fatal, though no remedy be applied. The only serious attack of fungus on adult salmon occurred during the experimental work at Craig Brook in 1871. The first inclosure made to receive the breeding fish was a small and shallow one, made by damming the brook itself at a point where its volume consisted of about 30 per cent of spring water. The fish had suffered considerably from the handling necessary in bringing them so far and from the rough character of the experimental cars in which they were transported. The first of them were placed in the inclosure June 8. On the 12th 2 of them died, on the 13th 2 more, and by the 17th 14 were dead out of 41 received; by the 20th the mortality had increased to such a point that it became evident that not a single salmon would survive unless some change was made in the mode of confining them, and they were all removed and placed in other quarters. Nine of them, already so badly diseased as to be considered hopeless cases, were turned loose in Craig Pond, and part of these recovered and spawned in the autumn following on a gravelly shore, where some of them were taken and found to bear the well-healed scars of their ugly sores.

The symptoms noted were sluggishness and heedlessness; an inclination to swim near the surface of the water; a white, filmy appearance of the eyes, which seemed to be accompanied or followed in many cases by blindness; a white fungoid growth on the abraded tips of the fins and wherever the scales had been rubbed off; white blotches breaking out on all parts of the body, even where there had been no mark of injury, particularly on the head, proving on examination to be patches of white fungus, which, on the parts of the body covered by scales, grew underneath the latter and pushed them from their places.

Experiments in confining salmon in other waters the same season turned out successfully, and it seems that the most important conditions in the case were these: The area of the fatal inclosure was about a quarter of an acre; the water was partly from springs and was so exceedingly transparent that a pin dropped into it could be readily seen at a depth of 6 feet, so that there was practically no protection from the rays of the June sun; the fish had been transported in a common dory with holes bored in the bottom to admit water, a very inferior sort of car compared with those now in use; they had been transported a long distance and passed three separate locks and had finally been hauled in a tub on a cart over rough ground from Alamoosook Lake to the inclosure.

The conditions at Craig Pond, where some of the worst cases recovered, were these: An area of 231 acres; a maximum depth of 69 feet; exceedingly pure and transparent water, like that of the inclosure.

At two of the other inclosures tried that summer, where there was no attack of fungus, the water was brown and dark, like that of ordinary brooks and ponds, and in the remaining one it was intermediate in character.

These facts point strongly to the character of the water as the cause of the fatality of the disease, and especially to its pellucid character, which exposed the salmon to an extraordinary glare of light, whereby the growth of the pest was greatly encouraged. The recovery in the transparent water of Craig Pond was rendered possible by the great depth of the water, through which but a small fraction of the light of day could penetrate. No doubt the salmon liberated there at once took refuge in the deeper parts. The suggestion naturally arises that artificial shade might be useful in the treatment of such diseases, whether the attacking fungus be identical with that observed in the above instances or a related one.

It is certain, from the promptness with which dead animal matter becomes the prey of saprophytic growths, that the spores of these water-molds are well disseminated throughout fresh waters, everywhere ready to seize upon an opportunity for germination and growth, and that as a general rule these spores are quite unable to seize upon any animal substance which is not already dead or in a diseased condition.

A growth of *Saprolegnia ferax* once established on the body of a salmon is able to extend itself upon and into the living tissues around it, which it seizes upon and destroys. Growing upon a dead egg, it not only ensnares the neighboring living eggs, but sometimes pierces their shells and establishes itself on the internal parts. In one instance the fungus had gone so far as to attach itself to a living embryo, which, on removal from the shell, was found to support on the sac quite a tuft of growing fungus, though neither on the sac nor any other part of the fish was a trace of dead substance discernible.

It has been ascertained that the *Saprolegnia* which attacked the living salmon can be communicated by contact to dead flies, and that *Saprolegnia* found growing in the ordinary way on dead flies in water can be communicated in its turn to living and healthy dace and may so flourish on them as to cause their death.

The impression has prevailed that the *Saprolegnia* which infests the eggs in hatching-troughs originates in or is encouraged by bare wood exposed to water, and that special effort is necessary to prevent its forming; but experience at this station does not show that attacks of fungus on either eggs or fish could be traced to bare wood, and, on the other hand, eggs and fish in troughs carefully varnished with asphaltum are no freer from fungoid or other disease than those in neighboring troughs from which long use had worn almost the last vestige of varnish.

The best precaution against this growth is the careful picking out of dead eggs before there is time for the fungus to grow on them, and in case of a serious attack on fry or older fish to treat them with an exterior application of salt, which, while not a cure-all, is very efficacious in cases of fungous diseases, and, if prudently used, a safe remedy for fish that have reached the feeding stage.

To apply this remedy to fry in the troughs a saturated solution of salt in water is made—that is, the strongest brine that can be made without heating the water. The flow of water in the trough to be treated is then stopped, which leaves it from 3 to 4 inches deep, when enough brine is poured in to make the water in the trough about as salt as common sea-water, about 1.028 specific gravity. The fish are left in this 20 or 30 minutes, unless they exhibit uneasiness, and then fresh water is turned on. Precaution is taken to dilute the brine with an equal quantity of water, to distribute it the whole length of the trough, actively stirring the water to secure an even mixture; and before turning on the usual water supply, a large quantity of fresh water is likewise poured in, distributing it the whole length of the trough and stirring as before, to guard against a too sudden change.

Such precautions are especially necessary in the application of salt to very young fish. A large number of salmon in the sac stage was once destroyed by pouring in a little brine without stirring it; it appeared to sink to the bottom and spread out in a layer by itself among the fry, and all exposed to it died.

ENEMIES OF YOUNG SALMON.

The young salmon are subject to the attacks of many animals and birds, such as the mink, mole, star-nosed mole, common rat, muskrat, kingfisher, great horned owl, great blue heron, sandpiper, and fish-hawk, besides frogs and all large fishes.

At Craig Brook the mink has caused serious loss in the ponds. As a protection some of the ponds are covered with galvanized poultry netting, and traps are kept constantly set in the avenues by which it is apt to approach. The mole burrows through embankments and thus sometimes causes trouble. The star-nosed mole is known to steal dead eggs, and is suspected of taking live ones. The rat sometimes takes young fish from the troughs. The muskrat burrows in embankments and sometimes eats fish.

The different fish-eating birds occasionally steal fish from the ponds or troughs, but if a careful watch is kept the danger is not great. Frogs may be exceedingly destructive to young salmon, and must be caught out of the fish-ponds.

To avoid loss from cannibalism among the fishes it is necessary to feed them well and to take great care that no large fish get in among the small ones.

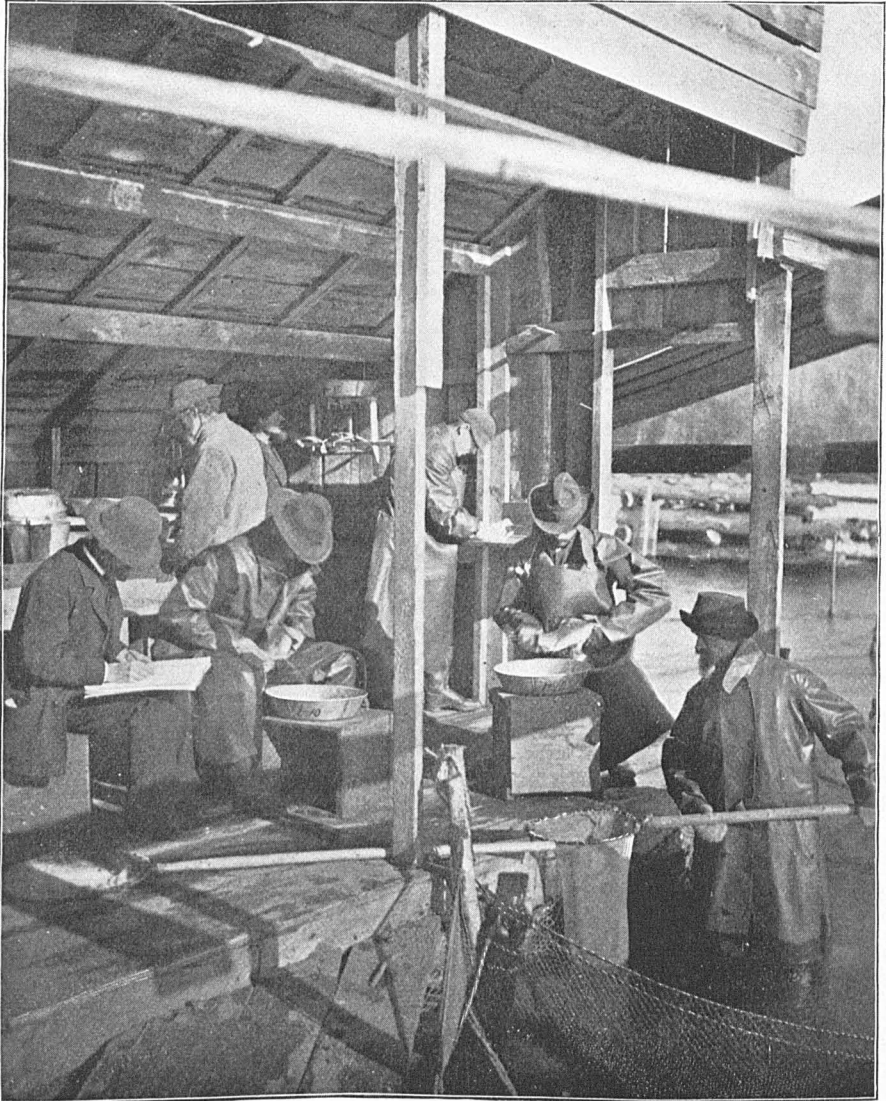

TAKING SPAWN OF LANDLOCKED SALMON AT GRAND LAKE STREAM, MAINE.

THE LANDLOCKED SALMON.

The landlocked salmon was formerly regarded as specifically distinct from the seagoing form, but it is now generally considered only a variety. The fish found in Sebago Lake and other localities in the United States is known as *Salmo salar sebago*, and the Canadian form as *Salmo salar ouananiche*. From the fish-culturist's point of view, however, the marked difference between the landlocked and the seagoing salmon in habits and growth must separate them as widely as any two species of the same family.

Landlocked salmon are known to exist only in some of the lakes in Sweden, besides the lakes of eastern North America. They are native to most of the lakes of eastern Labrador, including the waters tributary to Ungava Bay, and find their western limit in Lake St. John and vicinity, on the Saguenay River. Those of the latter district have been much written about under the name of "*ouananiche*."

Doubtless the absence of the migratory instinct is at the bottom of most of the variations from the normal type of *Salmo salar* which the landlocked salmon exhibits. The lakes afford a far poorer feeding-ground than the sea; hence, perhaps, the diminutive size and leaner flesh of the landlocked salmon. Its lower tone of color, less permanent sexual marks, and greater liability to ovarian disease, as well as different habits of feeding, may perhaps be referable to the same general cause. There are some other peculiarities, however, which are not so easily explained. For instance, the eggs of the landlocked salmon are considerably larger than those of the sea salmon, and the very young fry are correspondingly larger.

The growth of the young of the Sebago landlocked salmon seems to be more rapid than that of the anadromous salmon, for some specimens more than a foot long still bear on their sides dark, transverse bands, characteristic of young salmon; but it may be that the landlocked fish simply retain the marks of the immature stages to a later period of life. This view is supported by the fact that the dark bands are never completely obliterated from the sides of the landlocked salmon, being always very distinct, even in adult specimens, on the under side of the skin, a character absent among migratory salmon.

The landlocked salmon is smaller and more slender than the anadromous salmon, but its flesh is fat and rich and of a very delicate flavor. In game qualities it is, for its size, quite the peer of the larger salmon, and affords keen sport to the fly fisherman. It is, therefore, much sought after, and ranks in public favor among the foremost fresh-water species.

The natural range of the landlocked salmon in the United States is much restricted. Leaving out of the question the salmon formerly frequenting the rivers tributary to Lakes Ontario and Champlain, the extent of whose migration is a matter of doubt, we find them only in four limited districts, all in the State of Maine, namely, the Presumpscot River (including Sebago Lake) in Cumberland and Oxford counties, the Sebec River (a tributary of the Penobscot) in Piscataquis County, the Union River in Hancock County, and the St. Croix River in Washington County. There are some minor differences between the fish of these several districts, of which, perhaps, that of size is most notable. The Sebago and Union River fish are much larger on the average than those of the Sebec and St. Croix. The Sebago salmon average at the spawning season 4 or 5 pounds weight for the males and a pound less for the females, while specimens of 12 and 14 pounds weight are not rare, and there is a record of one of 17½ pounds. The Union River fish are about the same size. The St. Croix fish vary in the matter of weight in different parts of their range, but the average weight of either sex at Grand Lake Stream is a little less than 3 pounds; specimens of over 6 pounds are rare, and none is on record of over 10 pounds.

After attempts to collect eggs of landlocked salmon in each of the four regions mentioned, it was found that Grand Lake Stream in the St. Croix district afforded excellent facilities for this work. The hatching station at that place was operated continuously from 1875 to 1892. Since 1892 the station has been closed and the propagation of landlocked salmon by the United States Fish Commission has been conducted at Green Lake station.

The following notes on fish-cultural methods have special application to Grand Lake Stream:

The landlocked salmon of the St. Croix, though originally well distributed through the lakes tributary to that river and still inhabiting a great many of them, finds in some a much more congenial home than in others, its favorite abode being Grand Lake on the Schoodic River. This body of water is of irregular shape, about 12 miles in length and 4 in extreme breadth, fed almost wholly by short streams that form the outlets of other lakes, and from this cause, as well as from the fact that it drains a gravelly country and is girt with clean, rocky shores, it is one of the purest of the Maine lakes. Its greatest depth is believed to be a little more than 100 feet. Its outlet is Grand Lake Stream, a shallow, rapid, gravelly stream, about 3 miles long, to which the salmon go in October and November to deposit their eggs. Comparatively few of the salmon of this lake resort to the streams tributary to it.

The operations with landlocked salmon necessarily differ from those with migratory salmon. Being at home in fresh water and having there their feeding-grounds, they continue to feed until the close approach of the spawning time, and hence they could not be penned up in the summer without some provision for an artificial supply of food, which would probably involve a great deal of expense and trouble. More-

over, the necessity of collecting breeding fish early in the summer does not exist, because they are at no time more congregated and easy to catch than at the spawning season.

Their capture is easily effected by stretching a net across the outlet of the lake and leading them through a tunnel-formed passage into an inclosure of netting. There happens to be at this point a wide surface of smooth bottom, with water from 1 to 3 feet in depth, affording an excellent site for spacious inclosures, not only for entrapping but for assorting and storing salmon during the spawning season. Nets are generally stretched across the stream (to keep the fish back in the lake) immediately after the beginning of the close season, September 15. The earliest of them begin to spawn before the end of October, but the actual inclosing of the breeding stock is deferred until the early days of November. The taking of spawn generally begins about November 6 and continues two or three weeks. Commonly by November 20 or 22 this work is completed, and the breeders are carried a mile or two up the lake and liberated.

The method of manipulation is the same as at the Craig Brook station, and does not differ materially from that adopted by all the American breeders of *Salmonidæ*. The results in the impregnation of the spawn are not so uniformly satisfactory as with sea salmon. There appears to be a greater prevalence of ovarian disease than among the migratory salmon. The occurrence of white eggs among the normally colored and healthy ones as they are yielded by the fish is very common, and occasionally the entire litter is defective. It is not improbable that some eggs are incapable of impregnation, though exhibiting no visible signs of disease. However, the general result is satisfactory, the ratio of impregnated eggs being from 93 to 95 per cent.

The facilities for developing and hatching the eggs at Grand Lake Stream are rather poor. No good site could be found by the side of the stream, no suitable brook could be found near enough to the fishing-grounds, and the neighboring springs lacked either volume or facilities for utilization. Of three hatcheries, two use spring water exclusively, and one of them lake or stream water exclusively. The lake water is preferred, but unfortunately it can only be used for the slow development of part of the eggs, circumstances connected with the floating of timber down the stream compelling the evacuation of that hatchery in March. The main hatchery is well located except that the water is from springs, and this unfavorable circumstance is well counterbalanced by the facilities for aeration, which are very good and very fully employed. The eggs are placed upon wire-cloth trays in stacks or tiers, ten deep, and arranged for a free horizontal movement in the water.

The egg shipments are made in January, February, March, and sometimes in April. The eggs hatched are selected from those that have been retarded in development; the fry reach the age for liberation in June, when their natural food is believed to be abundant.

Experience at Green Lake has supplied some interesting data. Here we find the breeding-grounds of the salmon both in the affluents and in the effluent of the lake, but, unlike Grand Lake, mainly in the affluents. Great Brook, the largest tributary, is most resorted to, and on this stream is located the station of the United States Fish Commission. The most of the breeders are taken in a trap in the brook, which they readily enter when seeking to ascend to their natural breeding-grounds just above. The trap is constructed of wood and close to it, also in the bed of the brook, are numerous pens of the same material in which the fish are assorted and held during the spawning season. On the bank, snug by the pens, is the spawn-house, and a few rods away is the hatchery. The hatchery is supplied with water from Rocky Pond, the source of Great Brook, by a wooden flume 7,050 feet long, supported by wooden trestles, at some points elevated many feet above the ground. In cold weather the water cools off $1\frac{1}{4}$ degrees in passing down this flume; in warm weather it warms up $1\frac{1}{2}$ degrees. Though the summer temperature during the early years of the station was sometimes over 80° F. and some other species succumbed to the heat, the landlocked salmon endured it safely, and the only notable effect on them was that at 75° and upward the adults reared in the station ponds refused to eat.

As at the Schoodic station, among the adult wild salmon caught for breeding each year are many more females than males. In 1889 the proportion was 3 females to 2 males; in 1893 it was 9 to 4. The size of the Green Lake salmon is remarkable; the mean of 69 full-roed females in 1889 was 7.8 pounds in weight and 25.5 inches in length; the males the same year averaged 5 pounds in weight and 22.3 inches in length; one female weighed 11 pounds 9 ounces, and measured 30 inches; another, 11 pounds 6 ounces in weight, was $30\frac{1}{2}$ inches in length; one male, 31 inches long, weighed 13 pounds 8 ounces. The number of eggs yielded by the females is about 4,000 each.

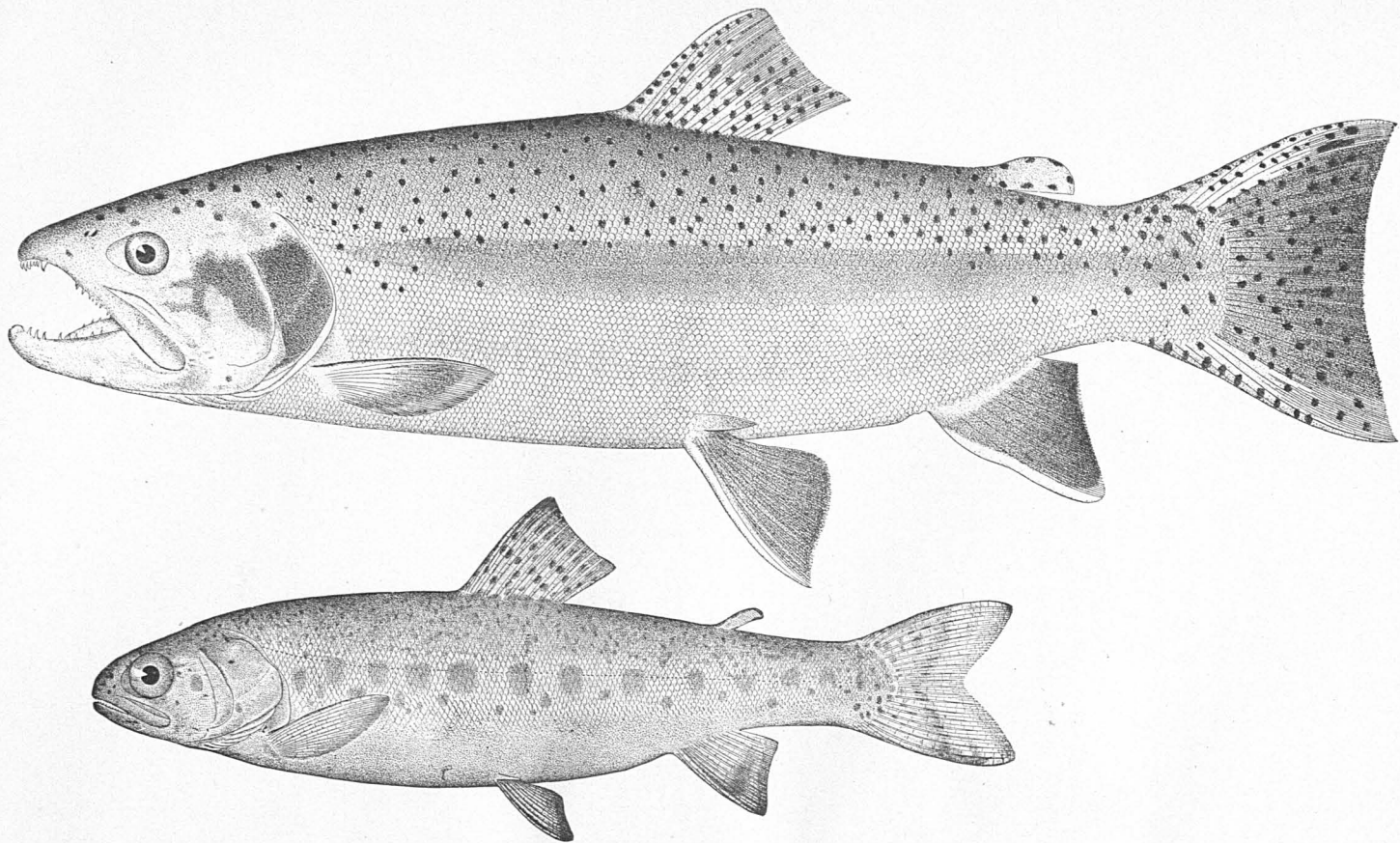

SALMO IRIDEUS. *Rainbow Trout*. Upper figure adult male, lower figure immature fish.

THE RAINBOW TROUT.

DESCRIPTION OF THE FISH.

The body of the rainbow trout (*Salmo irideus*) is comparatively short and deep, and is more elongate in males than in females. The average depth is contained about three and four-fifths times in the body length. The short head, which is obtusely ridged above, is about one-fourth the total length. The mouth is smaller than in other species of *Salmo*, the maxillary reaching scarcely beyond the eye, which is rather large, and is contained five times in the side of the head. The caudal fin is distinctly but not strongly forked. On the vomer are two irregular series of teeth. The dorsal rays number 11 and the anal 10. In the typical species there are about 135 scales in the lateral series, with 20 rows above and 20 below the lateral line; in the several subspecies the number of rows of scales along the side is from 120 to 180. The color is variable, depending on sex, age, and character of water. Typical adult fish are bluish above, silvery on the sides, profusely and irregularly dark-spotted on the back and sides, the spots extending to the vertical fins, with a red lateral band and blotches and a nearly plain belly. The sea-run fish are nearly plain silvery. The chief distinguishing color characteristics of the varieties are in the number and position of the spots.

RANGE AND VARIATION.

The rainbow trout is not indigenous to eastern waters, its original habitat being the Pacific coast of the United States. It is especially abundant in the mountain streams of California. A few specimens, however, have been taken in salt water, and it is not unlikely that some find their way through the rivers into the sea.

The species is subject to considerable variation in form and color in different parts of its range, and the following varieties have received recognition by ichthyologists: The brook trout of western Oregon and Washington (*Salmo irideus masoni*), which rarely weighs as much as a pound and is locally abundant in the streams of the Coast Range from Puget Sound to southern Oregon; the McCloud River trout (*Salmo irideus shasta*), which attains a large size, is abundant in the streams of the Sierra Nevada Mountains from Mount Shasta southward, and is the rainbow trout which has received most attention from fish-culturists; the Kern River trout (*Salmo irideus gilberti*), which attains a weight of 8 pounds, and is found only in Kern River, California; the noshee or nissuee trout (*Salmo irideus stonei*), which inhabits the Sacramento basin, and reaches a weight of 12 pounds; the golden trout of Mount Whitney (*Salmo irideus aqua-bonita*), which inhabits streams on both sides of Mount Whitney, California.

In the extensive section of the West in which the fish abounds its name varies in different localities; "red sides," "mountain trout," "brook trout," and "golden trout," besides "rainbow trout," are some of the popular appellations, while in the States east of the Mississippi River it is generally called "rainbow trout" or "California trout."

TRANSPLANTING.

The rainbow trout has been successfully transplanted in many of the mountain streams in different parts of the United States, where it grows and multiplies rapidly, as is shown by the many favorable reports. The best results, however, seem to have been obtained from plants made in streams of Michigan, Missouri, Arkansas, throughout the Alleghany Mountain ranges, and in Colorado, Nevada, and other Western States. It was introduced into eastern waters by the United States Fish Commission in 1880, but it is possible that specimens of it, or its spawn, had been brought east prior to that time by some of the State commissions or by private enterprise.

It is believed that this species will serve for stocking streams formerly inhabited by the brook trout (*Salvelinus fontinalis*), in which the latter no longer thrives, owing to the clearing of the lands at the sources of the streams, which has produced changed conditions in and along the waters not agreeable to the brook trout's wild nature. The rainbow is adapted to warmer and deeper waters, and is therefore suited to many of the now depleted streams which flow from the mountains through the cultivated lands of the valleys.

Rainbow trout differ widely from brook trout and other pugnacious fishes, in that they feed principally upon worms, larvæ, crustacea, and the like, and do not take readily to minnows as food. They should be planted in spring or early summer, when their natural food is abundant, as they will then grow more rapidly and become accustomed to life in the stream; and when worms, larvæ, etc., are no longer to be found, their experience and size will enable them to take a minnow or anything that may present itself in the shape of food.

In the Eastern States fry should not be planted in open waters until they are several months old, and then not until the temperature of the streams begins to rise; but fish hatched in December and January can safely be planted in April and May. On the Pacific slope the fry may be successfully liberated at any time after the umbilical sac is absorbed.

SIZE AND GROWTH.

The size of the rainbow trout depends upon its surroundings, the volume and temperature of the water, and the amount of food it contains. The average weight of those caught from streams in the East is probably less than a pound, but some weighing $6\frac{3}{4}$ pounds have been taken. In the Ozark region of Missouri they are caught weighing 5 to 10 pounds. In some of the cold mountain streams of Colorado their average weight is not more than 6 or 8 ounces, but in lakes in the

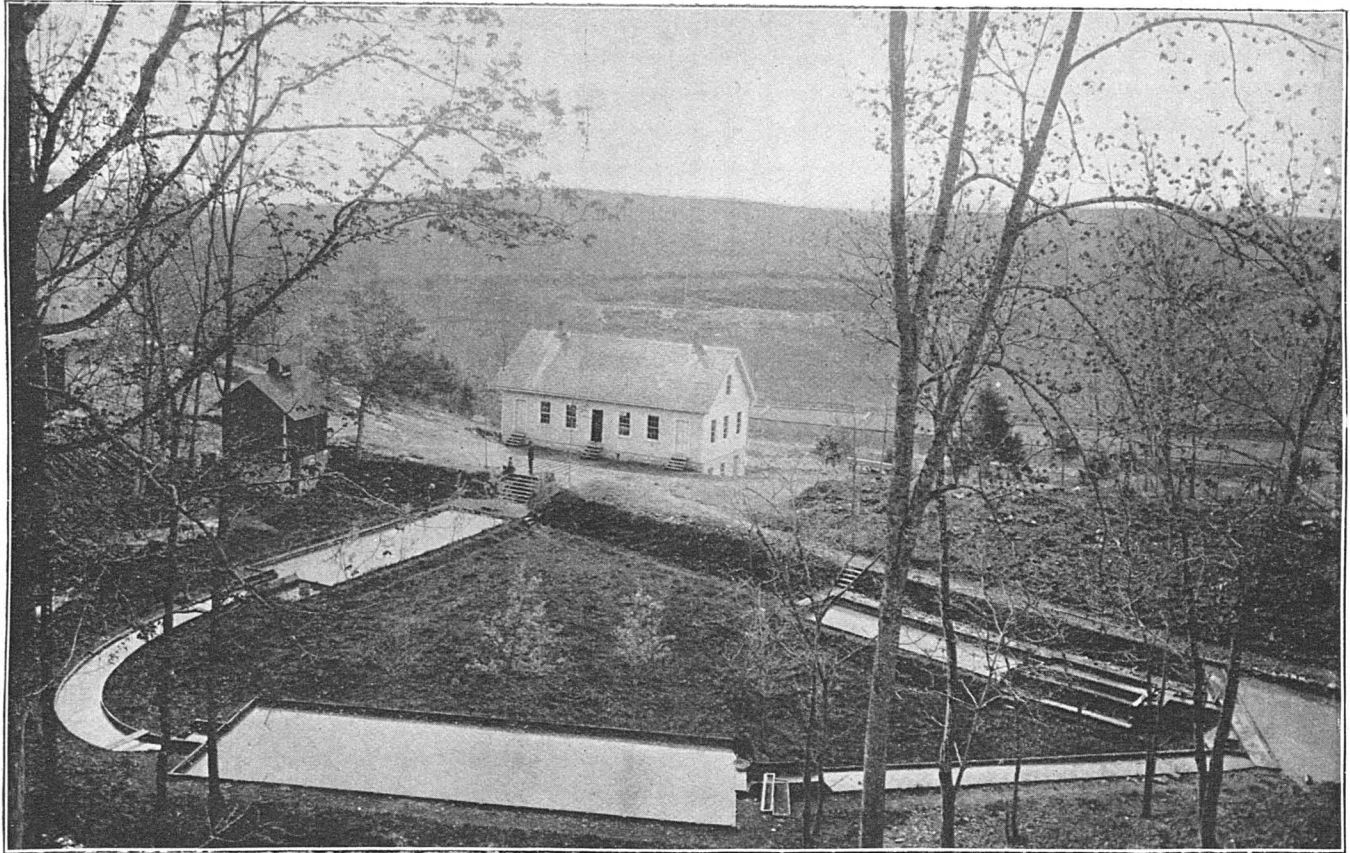

VIEW OF WYTHEVILLE STATION, SHOWING BREEDING PONDS, WITH HATCHERY IN THE BACKGROUND.

same State, where the water becomes moderately warm in summer and food is plentiful, they reach 12 or 13 pounds, fish of this size being from 25 to 28 inches long. In the Au Sable River, in Michigan, they attain a weight of 5 to 7 pounds. In their native streams of California they are often caught ranging from 3 to 10 pounds, but average from 1 to 2 pounds. The largest specimen ever produced in the ponds at Wytheville, and fed artificially, weighed 6½ pounds, but many others in the same ponds weigh from 1 to 3 pounds.

The average growth of the rainbow trout under favorable artificial circumstances is as follows: One year old, from ¾ to 1 ounce; 2 years old, from 8 to 10 ounces; 3 years old, from 1 to 2 pounds; 4 years old, from 2 to 3 pounds. They grow until they are 8 or 10 years old, the rate diminishing with age. Some grow much faster than others under the same circumstances, but the rate of growth is largely a question of food, temperature of water, and extent of the range. In water at 60°, with plenty of food, fish 1 or 2 years old will double their size several times in a single season; while in water at 40°, with limited food, the growth is scarcely perceptible.

The rainbow, like the brook trout, will live in water with a comparatively high temperature if it is plentiful and running with a strong current, but sluggish and shallow water, even with a temperature of 70° F., is dangerous for brook trout. Rainbow trout will live in warmer water than brook trout, and are found in swift, rapid streams at 85° F., especially where there is some shade, but in ponds that temperature is dangerous even with shade and a good current. In its natural condition this trout is usually found in water varying from 38° F. in winter to 70° F. in summer, and in selecting a site for a trout hatchery spring water with a temperature of 42° to 58° is required.

The rainbow trout is a superior game fish, a vigorous biter, and fights bravely for liberty, though in the East it is somewhat inferior to the brook trout in these respects.

SPAWNING-PONDS.

In constructing ponds, one of the first considerations is to place the fish absolutely under the control of the fish-culturist, that he may be able to handle them without delay or inconvenience. At Wytheville they are constructed entirely of wood, about 15 by 50 feet and 3 to 3½ feet deep, and shaped as shown in plate 22, and have been found very satisfactory. Excellent water circulation is obtained in all parts, and there are no corners for refuse to lodge in. The bottom of the pond is built with a gradual elevation, in the direction of the upper end, of 2 inches in the entire length of the pond. This makes it practically self-cleaning; nearly all of the foul matter will pass off and any remainder can be disposed of by drawing the water down low for a short period and then flushing the pond with fresh water. This method obviates the necessity of handling the fish, which is very important, especially when near the spawning time.

A guard-rack made of thin, narrow slats is arranged on an incline of about 45°, as shown at C. If the water is to be used again in ponds below, a receiver is built underneath the bottom of the pond at the lower end, between the foot of the guard-rack and the dam-boards, and the floor of the pond immediately over the receiver is cut away and fitted with a grating. This allows matter to fall through the receiver and from there it is washed through the sluiceway, which taps the receiver by drawing the gate shown at D. The sluiceway, E, is covered and leads off to a general waste-ditch.

The pond is provided with a spawning-race about a foot deep, 4 feet wide, and 25 feet long, placed at the upper end of the pond, as shown at H. Three division boards (shown at F), about 12 feet long and of suitable width to come within 1 or 2 inches of the surface of the water when the pond is filled, are firmly fixed at the bottom. The object of these boards is to form four avenues leading to the raceway, so that one or two pugnacious fish can not command the approach and keep back spawning fish inclined to enter. There is a dam across the raceway about 4 inches high (shown at G) for the purpose of bringing the water to that depth in the lower end, so that when the trout enter they will find sufficient water in which to swim freely, and not be inclined through fear to return to the pond.

The water in the pond is of sufficient depth to bring its surface within 6 inches of the top of the dam in the raceway, which will give the fish, in entering the raceway, a jump of 7 inches, allowing 1 inch for the depth of water on the dam in the raceway. This distance has been found more satisfactory than any other, and spawning fish alone will go up. If a jump of less than 7 inches is given, other fish can enter the raceway without much exertion, and will ascend and disturb the breeding fish, which, when spawning, should be kept strictly by themselves.

There is no rule regarding the supply of water that applies to a spawning-pond at all times and in all places. It is necessarily governed by the temperature of the water, size and shape of the pond, size of the fish to be supported, the amount of shade, etc. For a pond such as has been described, where water is plentiful, at least 200 gallons per minute should be provided, with not less than 75 gallons per minute as a minimum, even where the temperature is from 50 to 55 degrees and all other conditions are favorable. While the former amount is not absolutely necessary for the support of the fish, it insures the pond being kept clean and the fish are more inclined to enter the raceway at spawning time. In order to maintain an even temperature in the pond the earth is banked against the sides and ends, covering the framework shown on plate 25, and the embankments are made broad enough on top to admit of a good footway around the ponds.

Such a pond as this can accommodate from 1,000 to 1,500 breeding fish. Fish must not be overcrowded, and in estimating the capacity of

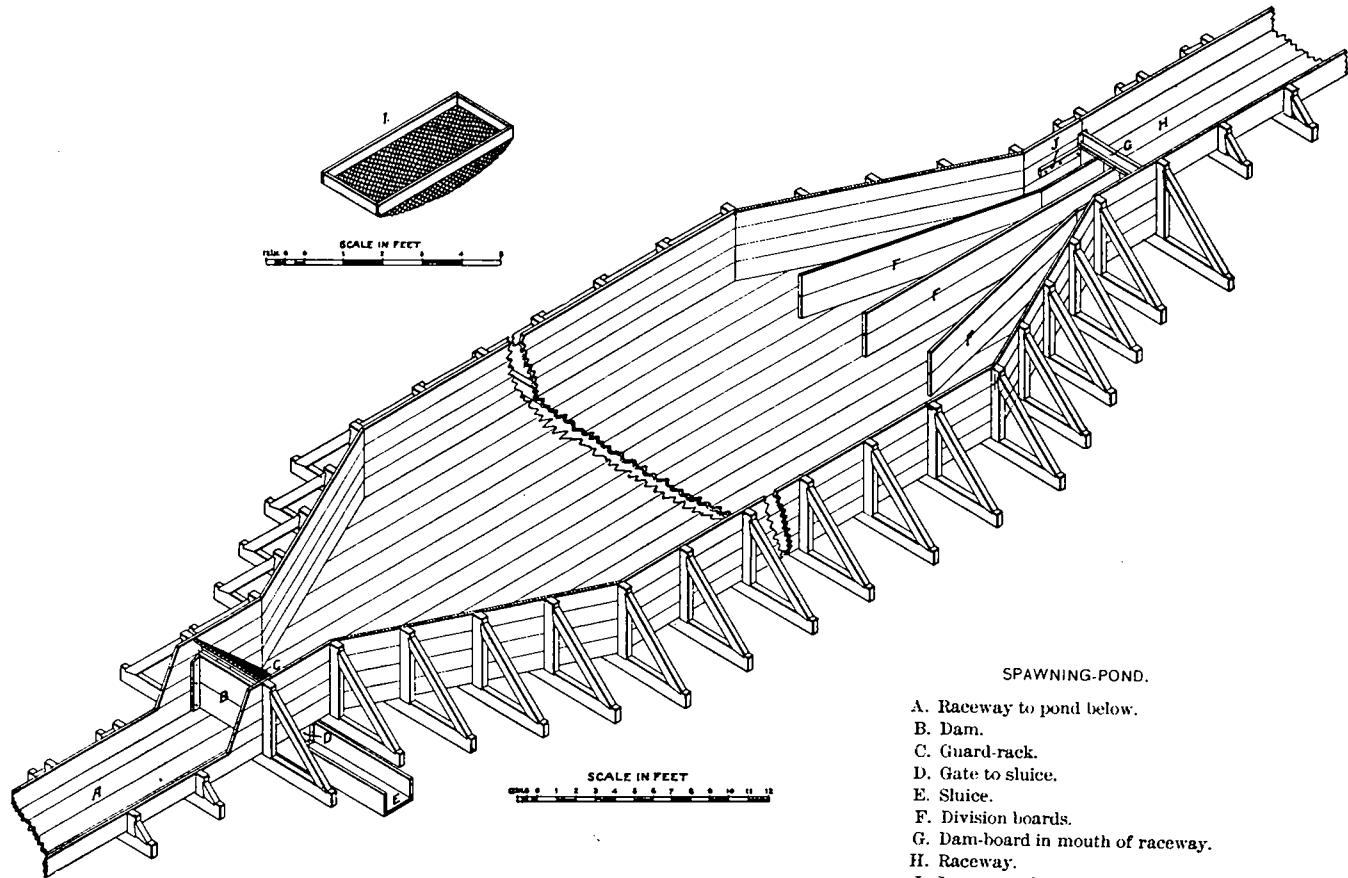

SPAWNING-POND.

- A. Raceway to pond below.
- B. Dam.
- C. Guard-rack.
- D. Gate to sluice.
- E. Sluice.
- F. Division boards.
- G. Dam-board in mouth of raceway.
- H. Raceway.
- I. Square net for capturing spawners.

a pond several modifying conditions must be considered, such as the size of the fish, water supply, temperature, and shade. In stocking the spawning-pond a good proportion is two females to one male. The breeding stock is selected carefully every year; only sound and perfect fish are retained for the next season, and the blind and emaciated fish of both sexes are destroyed.

TAKING THE SPAWN.

The spawning season varies with the locality and the temperature of the water. It is usually two to four weeks later in the streams than where the fish are kept confined in spring water. In the ponds at Wytheville the spawning fish may be found any time after the 1st of November; the season is well started by November 15, and generally closes about the 1st of March. December and January are the best months. In California the season extends from the 1st of February to May, and in Colorado begins early in May and continues until July.

The natural nests of these fish are made on gravelly bottoms, and are round or elongated depressions about the size of a dinner plate. After the eggs have been deposited and fertilized they drop between the pebbles of the nest, where they lie protected until hatched.

Where spawning-ponds are provided with suitable raceways the fish will ascend from the ponds into them, seeking a place to make their nests, and may then be taken out and stripped of their spawn. To take the fish from the raceway, a square net (I, plate 22) is dropped in on the cleats nailed against the side walls in the approach, shown at J, the dam in the mouth of the raceway is raised, and the fish driven back into the net. The net is then lifted out of the water, and if it contains too many fish to handle conveniently a landing-net is used to take out part of them before the square net is moved. The ripe fish are then placed in tubs or other vessels provided for the purpose. If too many fish are put in the tub at one time they become restless and sick before they can be stripped of their spawn.

There are two methods of taking and impregnating the spawn of fishes, the "wet" and the "dry" methods. By the "wet" method the eggs are taken in a pan containing sufficient water to cover them and allow them to mix freely with the milt, which is immediately added. After the contents of the pan have been stirred for a few seconds with a feather, the eggs are set aside and left undisturbed during fertilization. The "dry" or "Russian" method is now in general use; the eggs and milt are taken in a moist pan and it makes little difference which is taken first, but one should immediately follow the other, and the contents of the pan be thoroughly mixed.

After the eggs and milt have had time for contact, and before the eggs begin to adhere to the bottom of the pan, water is added to the depth of about an inch, the eggs being kept in gentle motion, by turning the pan, to prevent adhesion. After 2 or 3 minutes the milt

is poured off and clear water is put in the pan, in which the eggs are allowed to remain until they separate, which will be in from 15 to 45 minutes, depending on the temperature of the water. It is preferable to take the eggs to the hatchery before the milt and water are poured off, and there rinse them off and place them directly on the hatching-trays (previously arranged in the troughs) and then allow them to separate. In freezing weather it is advisable to strip the eggs in water or to use two pans, one set in the other, with water in the bottom pan to prevent the eggs from being chilled.

In taking spawn the manipulation of the fish without injury is a very delicate and exacting task, full knowledge of which can only be acquired by experience, as it is difficult to squeeze the spawn from the fish without injuring or even killing it. In taking hold of the fish in the spawning-tub the operator catches it by the head with the right hand, the back of the hand being up, and at the same time slips the left hand under the fish and grasps it near the tail, between the anal and caudal fins. A fish caught in this way can be easily turned over as it is brought out of the water, so that its abdomen is up and in the proper position for spawning by the time the spawning-pau is reached. If the fish struggles it must be held firmly, but gently, until it becomes quiet, and when held in the right position it will struggle only for a moment. A large fish may be held with its head under the right arm.

When the struggle is over the right hand is passed down the abdomen of the fish until a point midway between the pectoral and ventral fins is reached, then with the thumb and index finger the abdomen is pressed gently, and at the same time the hand is slipped toward the vent. If the eggs are ready to be taken they will come freely and easily, and if they do not, the fish is put back in the pond until ready to spawn. If the eggs come freely from the first pressure the operation is repeated, beginning at or near the ventral fin.

After the first pressure has been given, by holding the head of the fish higher than the tail, all of the eggs that have fallen from the ovaries and are ready to be expressed will fall into the abdomen, near the vent, so that it will not be necessary to press the fish again over its vital parts, the eggs having left that portion of the body. All of the eggs that have fallen into the abdomen below the ventral fin can be easily ejected without danger of injury to the fish, caused by unnecessary pressure over its important organs after the eggs have left that part of the body. If these directions are judiciously and carefully followed but little, if any, damage will result; and, as an illustration, it may be mentioned that fish have been kept for 14 years and their full quota of eggs extracted each season during the egg-producing term, which is normally from 10 to 12 years. The male fish is to be treated very much in the same manner as the female, except the milt must not be forced out, only that which comes freely being taken.

After stripping, the fish are not returned to the spawning-pond, but spent females are placed in one pond and the males in another. The



INTERIOR VIEW OF WYTHEVILLE HATCHERY, SHOWING MEN PICKING OUT DEAD EGGS.

males are very pugnacious at this season, and sometimes fight for an hour or more at a time, until they are entirely exhausted; they run at each other with open mouths, lock their jaws together, and in that position sink to the bottom of the pond, where they lie for a short time, each holding the other in his grasp until rested, when they rise and resume the combat. As their teeth are abnormally long, they scar each other and even bite pieces of skin and flesh from the sides of their antagonists.

The males are good breeders at 2 years old, but very few females produce eggs until the third season, when they are from 30 to 36 months old. At Wytheville hatchery about 1 per cent of the females spawn at 2 years of age; about 50 per cent at 3 years, and about 85 per cent each season after that. About 15 per cent of the fully matured females are barren each season. It was at one time thought that the same individuals were barren each year, but experience has shown that such is not the case, as fish which were barren one season have been held over, in a separate pond, until the following year, when a large portion, if not all, produced eggs. This sterility may be the result of injuries received during the previous season, during the progress of spawning.

EGGS.

The number of eggs produced in a single season depends upon the size and age of the fish. The maximum from one 3 years old, weighing $\frac{1}{2}$ to $1\frac{1}{2}$ pounds, is from 500 to 800; from one 6 years old, weighing 2 to 4 pounds, it is 2,500 to 3,000. The eggs vary in size from $4\frac{1}{2}$ to 5 eggs to the linear inch, and are of a rich cream color when first taken, changing to a pink or flesh-color before hatching.

THE HATCHING-TROUGHS AND TRAYS.

The eggs of rainbow trout are usually incubated on trays, placed in the water in troughs of various sizes and shapes. At Wytheville the troughs are set in pairs, as shown on page 78, are made of the best pine lumber dressed to $1\frac{1}{2}$ inches thick, and are 15 feet long, 14 inches wide, and 8 inches deep; 14 inches from the lower end inside is a guard-screen of perforated tin or wire mesh, fastened on a frame exactly fitted across the trough. Tin with perforations of $\frac{1}{16}$ inch for very young fry, and larger ones as the fish grow, is preferable to wire. The screen is arranged to slide vertically between beveled cleats, that it may be kept clean easier. A plain board $3\frac{1}{4}$ inches wide is placed 4 or 5 inches from the lower end of the trough to serve as a dam.

In the upper end of the trough horizontal screens (B, page 78), made of perforated tin, are used. These are so constructed that they can be slipped forward or raised up (as shown in the illustration) in feeding the fry or cleaning the troughs, and the water falling on a small wooden block in the center of the screen is thoroughly aerated before entering the trough. This arrangement possesses many advantages over the old method, where the screens were vertical, or nearly so, as it permits the

fish to ascend to the head of the trough and receive the water as it falls from the screen, which is very beneficial. Its use not only keeps the fry clean even in muddy water, but also reduces the loss of fry from suffocation in the early stages, caused by their banking around the vertical screens, and obviates the necessity for trough covers to prevent jumping, as trout rarely jump where the horizontal screen has been adopted.

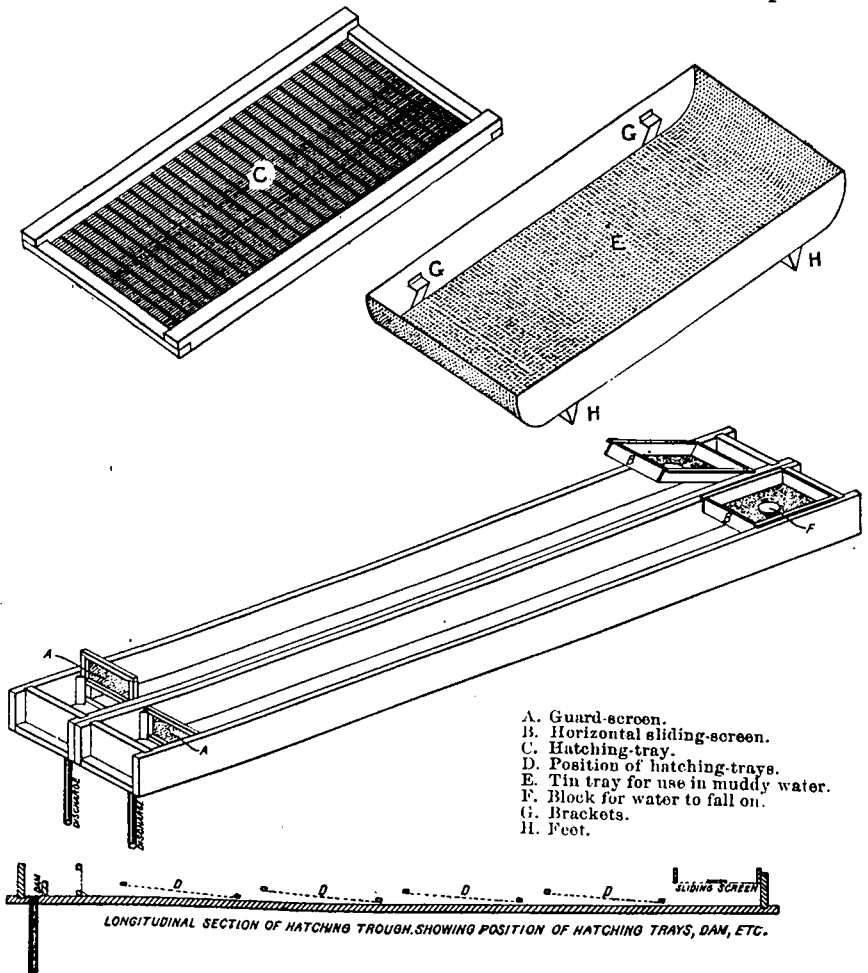

Hatching-troughs, Guard-screen, etc.

Hatching-trays (C), made about twice as long as wide, i. e., 28 by 13½, are convenient to handle and adjust in the troughs. The sides of the frame are made of good pine lumber, dressed, 1 inch square; the ends are dressed ½ by 1 inch, and are cut into the sides to form a smooth surface on the bottom for the wire filling. The wire used on the trays is woven with 8 threads to the inch, with a mesh ⅞ inch long, and should be well galvanized after it is woven, in order to prevent rusting at the laps.

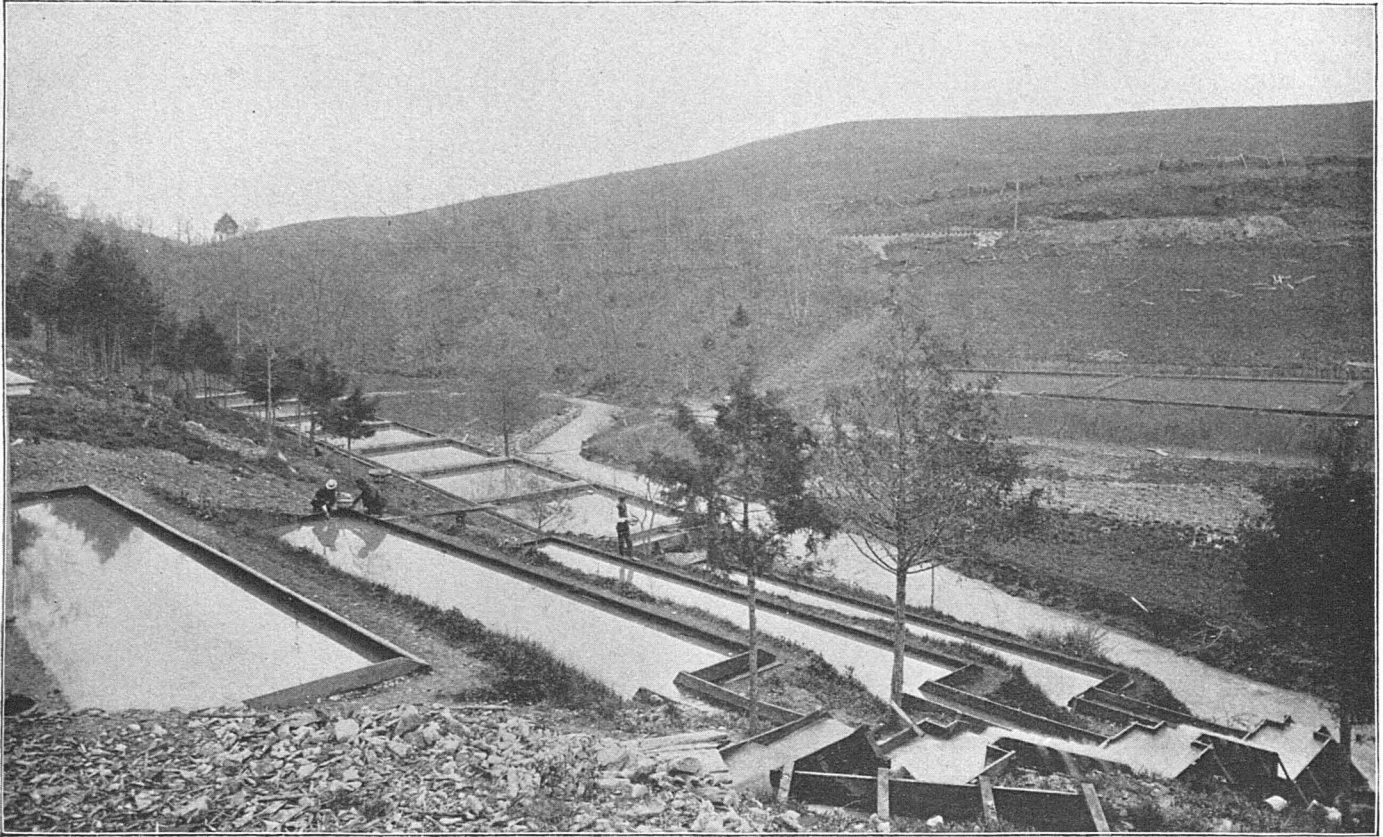

TROUT-REARING-PONDS AT WYTHEVILLE STATION.

Four hatching-trays are placed in each trough and are secured by keys or wedges, and should be from 1 to 2 inches lower at the end next to the head of the trough, as shown at D, D, D, D, page 78. If placed in this way, each tray will hold from 12,000 to 15,000 eggs with safety. Muddy water during the hatching season necessitates the use of a tin tray with a perforated bottom (shown at E, page 78), which is $13\frac{3}{4}$ inches wide and 32 inches long. This sets inside of the hatching-trough on feet raising it an inch above the bottom of the trough. The hatching-tray containing the eggs is placed inside and rests on the brackets shown at G. The fish, as they hatch out, fall from the hatching-tray upon the perforated bottom of the tin tray, and by their movements work the sediment through, leaving them on a clean bottom and in no danger of being smothered. The tin trays are also useful in counting fish, or in holding small lots of fish of different species in the same trough. Where supplementary trays are not used, the fry fall directly into the troughs.

Troughs 15 feet long will admit of four hatching-trays in a single row, each of which will safely carry 12,500 eggs, making 50,000 to a trough; this is enough to work easily, but if it is necessary to make more room a double row of trays may be put in, one tray resting on the top of the other. Thus the trough could contain 100,000 eggs as its full capacity. The troughs will carry this number up to the time of hatching by placing the trays lower at one end than the other, as previously described.

When the hatching stage arrives, two trays of 12,500 eggs each are as many as should be left in one trough; with this number, by using the horizontal sliding-screen in the upper end, there is but little danger of the alevins congregating and smothering in any part of the trough. If it is necessary to hatch a much larger number than this in one trough, the sliding-screen is so arranged that the water falls well up against the end of the trough. This is done by raising the screen and turning it back against the reservoir, or by putting in a wedge-shaped block for the water to fall upon, turning the thin side of the block toward the upper end of the trough. Fifty thousand trout have been hatched in one trough prepared in this way without loss from suffocation, but it is not advisable to hatch such a large number together.

The amount of water necessary for hatching and rearing depends upon the temperature and the manner in which the water is applied. The water should receive as much aeration as possible before entering the compartments containing the fish and eggs. At Wytheville, where there is an even temperature of water of 53° in the hatchery, about the following quantities are used in the troughs containing fish and eggs:

- 100,000 eggs during incubation, $12\frac{1}{2}$ gallons per minute.
- 100,000 fish hatching to time of feeding, 30 gallons per minute.
- 100,000 fish from 1 to 4 months old, 50 gallons per minute.
- 100,000 fish 4 to 6 months old, 100 gallons per minute.
- 100,000 fish from 6 to 12 months old, 200 gallons per minute.

These amounts are ample, and probably even half would suffice if it were necessary to economize in the use of water. In rearing-ponds more water is required, as the circulation is not so good and the outdoor exposure causes the temperature to rise. If water is plentiful, double the amounts stated would be advisable for pond-culture.

During the last two seasons at Wytheville 80 to 85 per cent of the eggs taken produced fish, of which about 70 per cent were raised to three months old and 55 per cent to yearling fish. The loss in eggs was almost entirely due to failure in impregnation, very few being lost from other causes.

CARE OF EGGS AND FRY.

After the eggs are placed on the trays, the only attention necessary until the hatching begins is to keep them clean; the dead eggs, which may be known by their turning white, must be picked out at least once each day. After the eye-spot can be plainly seen it is well to run a feather through the eggs for the purpose of changing their position on the trays, and to disclose any foreign matter or dead eggs that may be hidden underneath. The greatest care should be exercised in handling the eggs at any time, particularly from the first or second day after collection up to the appearance of the eye-spot, and then only when absolutely necessary. During this period, the eggs are very delicate, and even passing a feather through them may cause a heavy loss.

The time required for hatching depends mainly upon the temperature of the water. Rainbow trout eggs will hatch in water at 50° in from 42 to 45 days, each degree colder taking 5 days longer, and each degree warmer 5 days less; the difference increases as the temperature falls and diminishes as it rises.

After the fry hatch they require but little attention until the umbilical sac is absorbed and the time for feeding arrives. They are examined each day, and the dead fish and decayed matter removed from the troughs, which are kept perfectly clean, and if possible provided with a thin layer of coarse white sand on the bottom, to keep the fish in healthy condition. As the fish grow they should be thinned out in the troughs, from time to time, as their size may require. When they first begin to feed, 12,000 to 15,000 fish to the trough are not too many; but by the time they get to be $1\frac{1}{4}$ to $1\frac{1}{2}$ inches long they must be divided into lots of 8,000 to 10,000 to each trough; while with fish averaging 3 inches in length, 3,000 to 4,000 are as many as one trough will accommodate. It is advisable to give as much room as is practicable.

REARING-PONDS.

Ponds for rearing trout are from 8 to 12 feet wide, and of any desired length up to 60 feet, which, for convenience in drawing them off and in feeding the fish, is about the extreme limit. The size, shape, and arrangement of the ponds must depend upon the ground on which they are to be constructed. If practicable, it is best to build them on a

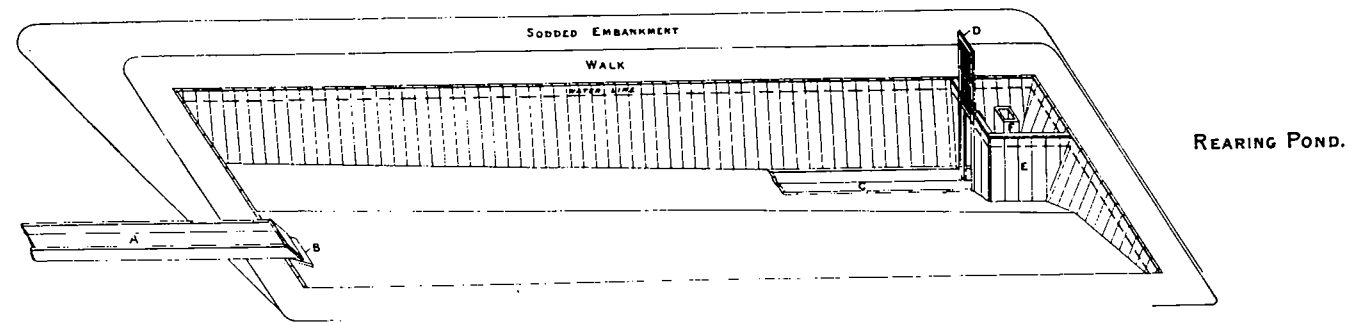

REARING POND.

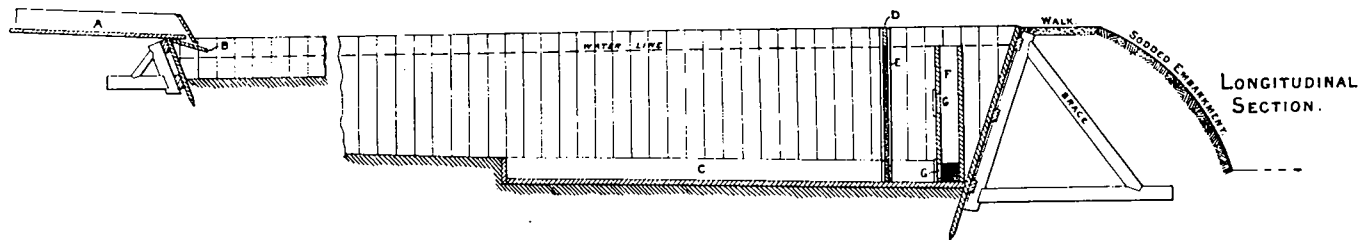

LONGITUDINAL SECTION.

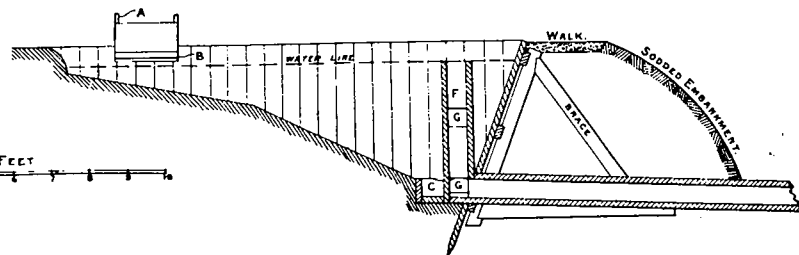

CROSS SECTION.

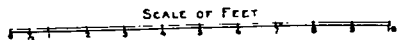

A. Supply-trough.
B. Apron.

C. Receiving-trough.
D. Guard-screen.

E. Crib around standpipe.
F. Standpipe.

G. Holes in standpipe.

REARING POND.

hillside, one above the other, with earth and piling embankments on the lower sides and at the ends. A pond of this kind is shown in plate 25, and is the one here described. Various materials may be used for damming the water. The embankments may be made altogether of earth or lined with stone, brick, cement, or timber, according to circumstances. Where the ground is of a porous or loose formation it is necessary to use piling or cement for the inside of the embankments and possibly cement for the bottoms, but earth bottoms are best where the nature of the ground permits. The water enters the pond at one end and discharges from the lowest opposite corner. The bottom is graded as shown in the cross-section, plate 25, with a slope toward the outlet, so that when all the water is drawn out the fish are led into the receiving-trough (C), the top of which is flush with the earth bottom in that part of the pond.

The outlet for the water is an L-shaped pipe, shown at F, and is placed in the corner of the pond, the long end passing through the piling and underneath the pond embankment; the short end, called the standpipe, stands close to the inside corner of the pond, in an upright position. The standpipe has two or more holes cut through (G) on the side next to the receiving-trough, to let the water pass out in drawing down the pond. The size of these holes is in proportion to the size of the standpipe, which, in turn, is governed by the size of the pond. The holes may have blocks of suitable size tacked over them to allow the pond to fill with water, or, what is more convenient, covered with blocks arranged to slip down in grooves, one block resting on the other. Surrounding the standpipe is a crib, the front of which is 15 inches or more from the pipe and contains an opening for a guard-screen, which is 14 to 16 inches wide and made with copper or galvanized wire cloth, the size of the mesh depending on the size of the fish in the pond. In the bottom of the pond is a receiving-trough (C) for the fish, built in proportion to the size of the pond; 10 feet long, 16 inches wide, and 6 inches deep is a satisfactory size for a pond like the one described. This trough extends to and connects with the standpipe, and the guard-screen is arranged to fit down on the inside. Every part is made secure, to prevent fish from escaping when drawing off the water. The supply-trough or pipe is arranged to keep the fish from jumping into it from the pond, as shown at A.

STOCKING THE REARING-PONDS.

The rearing-ponds at Wytheville are stocked gradually, 500 to 1,000 fish being placed in the pond and trained to take food before more are added, as that number can generally find enough natural food to subsist upon until they learn to take artificial food. When they have been accustomed to hand-feeding another 1,000 fish are added, and in about ten days 2,000 more, this practice being continued until the pond is stocked with the desired number. When fish are first released in ponds

they are wild and run away from the food given them; hence the necessity of teaching a few fish to eat before more are added. The number of fish that a pond of a given size can support depends upon the amount of water and shade and the temperature of the former. Ten thousand fish are ample for a pond 10 by 50 feet, with water deepening from 3 inches to 3 feet.

FOOD FOR FRY.

Beef or sheep liver, ground or chopped to a pulp, seems to be the most satisfactory artificial food for young trout. Fresh, hard-boiled eggs, grated fine, are good, but expensive. Efforts have been made to produce a natural or living food, such as insect larvæ and small crustaceans, and this may yet be accomplished for late spring and summer feeding, but for feeding the fry during the first three or four months of their lives, which is in the winter season, there is nothing better than liver. Shad and herring roe, put up in sealed tin cans, have been used to a limited extent with satisfactory results, and it is believed that they will furnish a wholesome and natural diet.

The manner of feeding young fry is very important, as the losses from improper feeding are greater than from all other causes combined. If there is undue haste the water becomes polluted, or the food is so distributed that some fish are prevented from getting their proper share. Polluted water is very injurious to the young fish, being apt to produce inflammation of the gills and a slimy, itching condition of the skin, which often causes heavy mortality.

The fry are ready to take food as soon as the sac is absorbed, the time required for this depending upon the growth of the fish, which is governed by the temperature of the water. Where the temperature is regular at 53° they will take food in about 30 days after hatching, and the time to commence feeding may be closely determined by watching the movements of the fish. Before the sac is entirely absorbed they will begin to break up the school on the bottom of the trough and scatter through the water, rising higher and higher from the bottom each day, until they can balance themselves gracefully in a horizontal position, all heading against the current and swimming well up in the water. By dropping some small bits of cork or the nap from red flannel on the surface of the water it can be determined if they are ready for food; if they strike at the pieces as the current carries them down it is evident they are hungry.

The liver is prepared by chopping it very fine and, if necessary, mixing it with water, in order that it may be distributed evenly. It should be given to the fish by dipping a feather into the liver and gently skimming it over the surface of the water. After the fish grow to be $1\frac{1}{4}$ to $1\frac{1}{2}$ inches long they begin to take up the food that settles on the bottom of the trough; it is then not necessary to mix the food with water, and it can be given by hand. The young fry are fed five or six times a day and the food given slowly and sparingly. After they

learn to take their food from the bottom of the trough it is necessary to feed them only three times daily, but more food must be given at each meal.

FOOD OF ADULT FISH AND YEARLINGS.

In domestication the rainbow trout is preferably fed upon a meat diet altogether, if it can be had plentifully and sufficiently cheap; otherwise a mixture of liver and mush may be used advantageously. The mush is made by stirring wheat shorts or middlings in boiling water until the mixture becomes thick; it will keep for several days, even in warm weather, if put in a cool place. The liver is ground or chopped fine and mixed thoroughly with the mush in any desired proportion up to four-fifths of the whole, but it is better to mix only as needed. This mixture has been used satisfactorily for many years.

A meat-chopper may be obtained for grinding liver which will do the work in an excellent manner, leaving no strings or gristly chunks to choke the fish. There are several sizes of the machine made, with extra perforated plates having different-sized holes, from one-twelfth to one-fourth of an inch in diameter, so that the meat may be prepared coarse or fine, to suit the size of the fish to be fed. For small fry it is necessary to use the plate having the smallest holes and to grind the food over several times until fine enough to use.

The practice of throwing food into the pond in handfuls causes the fish to come together in great numbers and in a violent manner; and struggling with open mouths to get a bite of the food, they often hurt each other, injure one another's eyes, sometimes even plucking them from the sockets. This is probably one of the main causes of blindness among pond-fed fish.

The most approved method of feeding is to walk along the pond its entire length to the upper end (the fish will soon learn to follow to that point), then scatter a handful of food along the surface of the pond so that it will fall to pieces. The fish follow and take up what has been thrown out and then return to watch for the next handful, and the operation is repeated until sufficient food is given. This manner of feeding induces all the fish to head in the same direction while eating, thus reducing the danger of injury.

The amount of food for a given number of trout depends upon the size of the fish and the temperature of the water, as fish will not take food as freely in a low temperature as they will in warmer water. With water from 50° to 60° a daily ration for 1,000 yearling fish ranging from 3 to 5 inches in length is about $\frac{3}{4}$ of a pound; while for the same number, 8 to 12 inches long, about 12 pounds per day are required.

As the fish increase in size the amount of food should be increased proportionately. They are fed twice a day at regular hours, morning and evening, giving half of the daily allowance each time. This keeps them in a thrifty and growing condition.

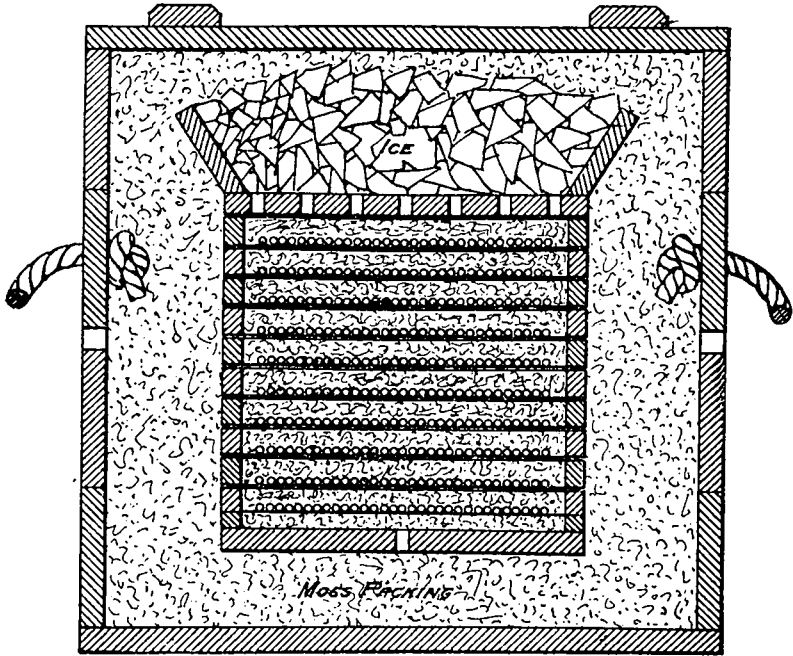

Cross-section through Box after it has been packed and closed.

PACKING EGGS FOR SHIPMENT.

In packing trout eggs for shipment they are usually placed on trays and packed in wet moss and the eggs divided into from five to ten equal parts, according to the size of the shipment, using trays of suitable size to hold each part. If 30,000 eggs are to be shipped, ten trays are used large enough to contain 3,000 eggs each; if 15,000 eggs, ten trays

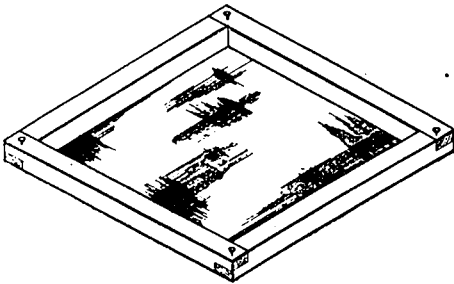

A. Egg-tray.

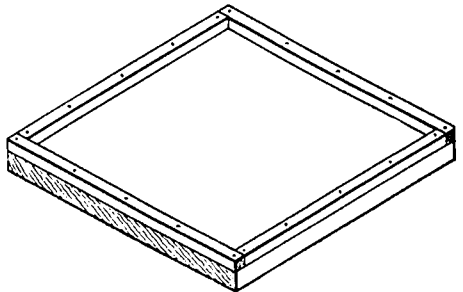

B. Foundation-board.

containing 1,500 eggs each; 10,000 eggs, eight trays of 1,250 each, etc., and if over 30,000 eggs are to be shipped the shipment is made in more than one lot. In a package of more than ten trays, especially if the trays are large, the eggs on the lower trays are liable to be crushed

by the weight above, and if less than five trays are used in a shipment the package is liable to become dry, and the eggs reach their destination either dead or in a shriveled condition.

The frames of the trays are made of light, soft wood dressed to $\frac{5}{8}$ by $\frac{7}{8}$ of an inch, with a soft canton-flannel bottom tightly stretched and well tacked on. The trays are made large enough to contain their proportion of the eggs, with an allowance of $\frac{3}{4}$ of an inch between the eggs and the frame of the tray. A foundation-board (B) is made with the same outside dimensions as the tray, with a strip nailed around the edge on the upper side to form a cushion of moss for the bottom tray. A hopper for ice (C) is used on the top tray. The outside case (E) is made 7 to 8 inches larger on the sides (inside measure) and 5 inches deeper than the outside dimensions of all the trays after they are cleated together, including the hopper and the foundation-board, as shown at D.

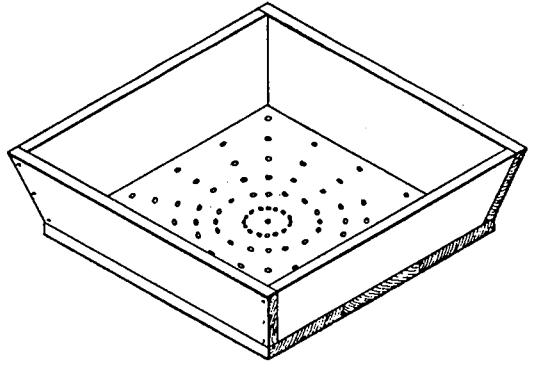

C. Ice-hopper.

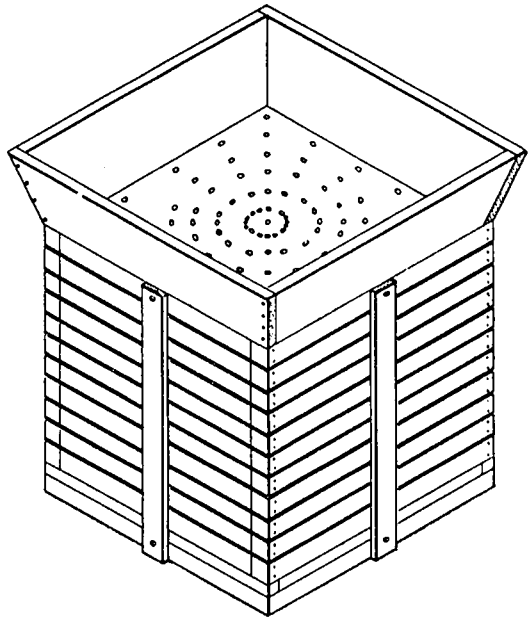

D. Egg-trays packed and cleated.

The trays having been prepared, the eggs are selected, those being taken which show eye-spots and are not too old to reach their destination before the time for hatching. Allowance is made for changes in temperature on the road which would cause them to hatch too soon.

The eggs are taken from the hatching-trays in pans, well cleaned of all sediment, and given a slight concussion by allowing water to fall on them from a small spout or sprinkling pot, which causes the dead and unfertilized eggs to turn white, when they are carefully removed. The

eggs are then accurately weighed or measured (1 ounce may be weighed and counted, or the eggs for one tray counted and then weighed) and the required number placed in a single layer in the middle of the tray, leaving an empty space all round next to the frame.

The trays are then placed one above the other on the foundation-board, after each is covered with a piece of mosquito netting, which should be at least 2 inches larger each way than the tray, and the

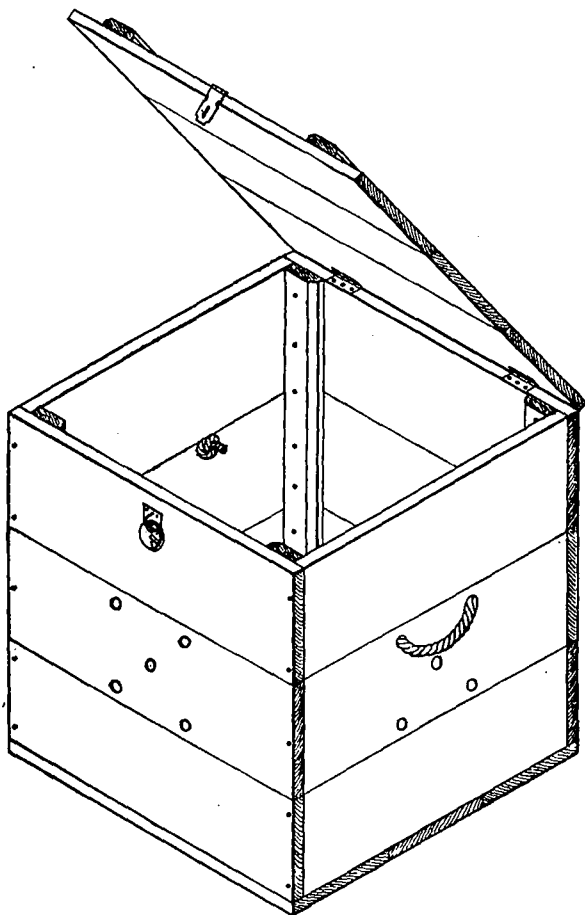

E. Outside case.

tray is filled with wet moss, the part immediately over the eggs in a loose manner, the empty space around the eggs packed tight. This gives support to the next tray above and prevents the eggs from coming in contact with the wood and becoming dry and shriveled.

After all the trays are thus arranged the hopper is placed on top and the whole cleated together, as shown at D. They are then ready to be placed in the box or outside case (E). Dry sphagnum moss is placed

in the bottom of the box to a depth of about 3 inches and the crate of trays placed as near the center of the box as possible. The sides are well packed to hold it firmly in position, and when the top of the hopper is reached with the packing it is well filled with ice, the remaining space in the box being filled with moss. Wet moss or wet packing of any kind should never be used for the cushion around the egg-crate, as it does not preserve an even temperature and is liable to freeze solid if exposed to a low temperature in transit. A cross-section of the box thus packed is shown on page 84.

The box containing the eggs should be provided with handles to facilitate moving during transportation, in order that the liability to injury from jarring or concussion may be reduced. For a long journey the lid of the box is provided with hinges and hasp and staple, so that the ice may be easily renewed. Eggs packed as described above have been shipped with safety to all parts of the United States and to foreign countries.

DISEASES OF FRY AND ADULTS.

The most common diseases of trout fry are the inflammation of their gills and a slimy skin disease, which may be caused by impure water; the food itself may produce it, especially if stale liver is used, but it generally follows fouling of the water while feeding. By watching the movements of the fish, the symptoms of disease can generally be detected before it reaches an alarming stage. If the gills are affected the fish will usually swim high in the water in an uneasy, restless manner, as if gasping for breath, and when this is observed the gills must be examined to see if they are becoming inflamed and swollen. If a skin disease is attacking the fish, they generally indicate it by rubbing themselves on the bottom of the trough or against anything that may be convenient, or by diving down and giving themselves a quick, twisting motion against the bottom of the trough. If the progress of disease is not promptly checked, it will soon reach a stage where nothing can be done, and the fish grow weaker every day until they begin to die in alarming numbers. One of the best remedies for both diseases is salt sprinkled through the water after the ponds are drawn low, and for a bad case of skin disease a half pint of salt for every gallon of water in the trough is used, or about that proportion. The fish should be watched closely and allowed to remain in the salt water until they become restless and begin to turn on their sides. Then, as fresh water is turned on and the trough fills, a slime will arise and float on top of the water, like a white scum. Coarse sand should be kept in the trough for the fish to rub themselves against. Salt is also good for the diseased gills and will free them from adhering sediment.

Fungus, "blue swelling," and other diseased conditions sometimes occur, but the most serious diseases of the fry are those just described. Parasites sometimes attack the fish, but if the water is pure and the fish in a healthy condition, they are not troublesome. To keep the fish

that are raised in troughs and tanks in a healthy state, it is well to give them a salt bath occasionally, and a small quantity of salt in their food will at times do them good. A little sediment from the reservoir, or such as collects on stones in the streams, is beneficial to fish if mixed with their food. It seems proper that they should have something of this nature, since all or nearly all of their natural food contains more or less sediment of the kind.

A very serious disease among adult rainbow trout shows the following symptoms: The afflicted fish refuse to take food, and very dark spots, from $\frac{1}{4}$ to 1 inch in diameter, appear on different parts of the body, varying in number from two or three up to twenty or thirty on each fish affected, a light spot about the size of a green pea appearing on the head immediately over the brain. The fish become restless and seek the shallow water in the corners of the pond, hiding among the plants, and begin to die within twenty-four hours from the time the disease is noticeable. They jump and dart around in the water in a frightened manner, settling back on their tails and sinking to the bottom of the pond in their last struggles. This disease made its appearance at Wytheville in December, 1895; it was first observed among a lot of 637 yearling Von Behr or brown trout that had been delivered at the station on November 29. The first sign of the disease was noted about the 5th of December, and by the 12th of the month 455 of the 637 fish were dead.

These fish were in the nursery during the first stages of the disease. The water in which they were held passed from them through an empty pond into a second one containing about 1,000 large rainbow trout that had recently been stripped of their spawn. On the morning of December 23 the disease made its appearance among the latter, and by 4 o'clock in the afternoon of the same day 56 of them had died. Salt was applied and the water in the pond was drawn down to about 300 gallons, and 150 pounds of common salt were sprinkled evenly through it. The fish were allowed to remain in this brine about 15 minutes, when they showed signs of weakening by turning on their sides; then fresh water was turned on freely. Good results were at once noticeable, the fish became quiet and appeared to rest more easily, and steadily improved, another application not being necessary. The final result was that 70 per cent of the adult rainbow trout that had been treated with salt were saved, while of the yearling brown trout that were not thus treated nearly 71 $\frac{1}{2}$ per cent died.

Foul ponds cause disease, and if the fish become sick from this reason, they must be removed to a clean pond at once and given a salt-and-clay bath, which is applied as follows: While the salt bath, before described, is being given, 2 or 3 bushels of clay are placed in the reservoir or supply-trough, and when the fresh water is turned on after salting, the reservoir is flushed for 30 minutes with roily water from the clay, and after the latter is washed away an increased amount of fresh water is turned on for ten days or more.

Adult fish are very liable to be affected with fungus, which generally appears after a bruise or hurt, or when the fish are in an emaciated condition. If the trouble results from an injury, it can often be cured before it spreads to the sound flesh, but if fungus spreads like a slimy web all over the fish, it is fatal. Fish must be handled very carefully during the spawning season to prevent scarifying the body in any way, as they are especially susceptible to fungus at that period. Should it occur, the fish must be caught at once, rubbed with salt on the affected part, and then released in a pond or tank by itself, where it can be caught for further treatment in a day or two, while those affected all over the body should be killed and thrown out at once.

"Glassy eggs" may be the result of overretention of the eggs on the part of the parent fish. If the eggs are not delivered within a reasonable length of time, say from 36 to 48 hours after they fall from the ovaries into the abdomen, they are surrounded with a thin watery fluid, having a glassy appearance, which if allowed to come in contact with water will change to a milky white, and the eggs absorbing this fluid become hard and "glassy," after which fecundation is impossible. Many thousand eggs have been lost annually on this account, and many brood fish lost or rendered worthless from the same cause. The fish in captivity will not spawn of their own accord unless they have access to gravel or earth in which to make nests. If attention is not given to the spawning fish and their eggs taken when ripe, they soon become very dark in color, the abdomen swells, and sometimes the head will enlarge, causing the eyes to protrude. Under these conditions the fish will die in a few days, but with free and easy access to the raceway they will not often be thus affected.

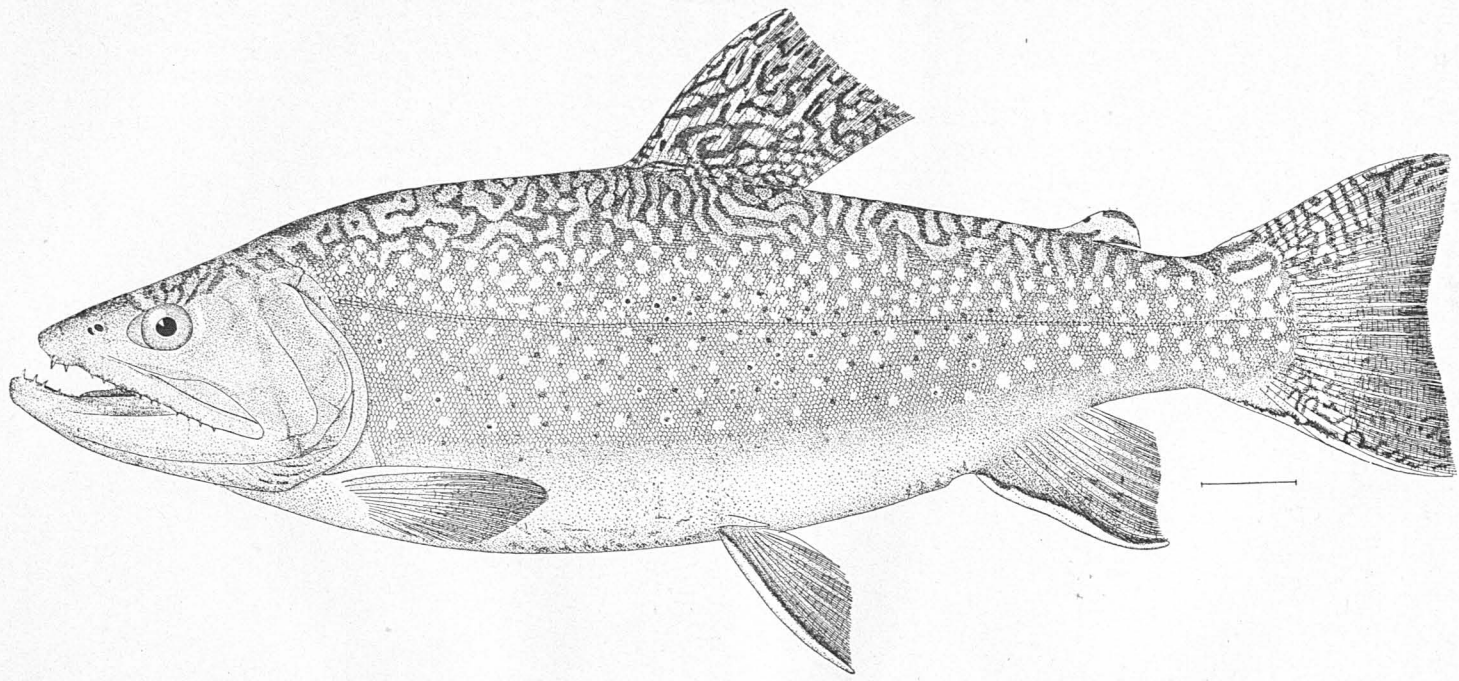

SALVELINUS FONTINALIS. *The Brook Trout.*

THE BROOK TROUT.

DESCRIPTION OF THE FISH.

The brook trout or speckled trout (*Salvelinus fontinalis*) is one of the most beautiful, active, and widely distributed of the American trouts. It prefers clear, cold, rapid streams, and belongs to that group of trout known as charrs, characterized by the presence of round crimson spots on the sides of the body. Other members of this class are the saibling or charr (*Salvelinus alpinus*) of Europe and Greenland; the Sunapee trout (*S. alpinus aureolus*), found in parts of New Hampshire and Maine; the blueback trout (*S. oguassa*) of the Rangeley Lakes in Maine, and the Dolly Varden trout, red-spotted trout, or bull trout (*S. malma*) of the Pacific States and Alaska. The lake trout also belongs in this group.

The general form of the brook trout's body varies considerably, sometimes being elongated and sometimes rather short, but the usual depth is about one-fourth or one-fifth of the length. The head is large and blunt, and is contained $4\frac{1}{2}$ times in the body length. The large terminal mouth is provided with teeth on the jaws, tongue, and palate bones, and also with a small patch on the vomer. The eye is placed high in the head; its diameter is about one sixth the length of head. The gill-rakers on the first arch number about 17, of which 11 are on the lower arm. The scales are very small and numerous; about 230 are in the lengthwise series, and 35 above and 35 below the lateral line. The dorsal and anal rays are 10 and 9, respectively. The tail is square or slightly lunate in the adult, forked in the young.

There is considerable variation in the color of the brook trout, dependent on local conditions, sex, and age. The head, back, and sides of the body, dorsal and caudal fins are of a grayish or greenish color; the back, head, dorsal, and base of caudal are mottled with dark green or black. In the male there is a reddish band along side of belly. Along the middle of the side there are numerous round light-red spots surrounded by whitish or light-brownish circular areas. The lower fins are dusky, with a pale or cream-color anterior border bounded by a black streak; remainder of fin often red in breeding males.

The brook trout may be distinguished from the other charrs by the dark-brown or black marblings on the back and the general absence of spots on the back.

FOOD, SIZE, ETC.

The brook trout has a voracious appetite and takes advantage of every opportunity to satisfy it except in the spawning season, when it takes no food at all. It is strictly a carnivorous fish, its food consisting chiefly of crustacea, mollusca, and various forms of insects and worms. When pressed with hunger it does not hesitate to devour its own kind.

The size of these fish varies in different localities, usually in proportion to the abundance of natural food and to the size of the body of water in which they are found. They seldom, however, exceed 2 pounds. The Au Sable River trout will rarely run as large as 2½ to 3 pounds, but in other rivers of Michigan larger examples are occasionally found. In southern New York they seldom weigh over 2 pounds, while in the Rangeley Lakes, of Maine, they have been caught weighing 10 pounds. The rate of growth also varies with the surrounding conditions and is more rapid in water of higher temperature and with a plentiful supply of food. Under favorable circumstances an average growth for the first year is from ¾ to 1 ounce, in two years 8 to 10 ounces, in three years about 1 pound.

While not of any considerable commercial importance, the brook trout is highly esteemed as a table delicacy on account of the flavor and quality of its flesh, and, as it is very game, it is much sought after by sportsmen. Those from clear, swiftly flowing streams do not grow so large as those found in quiet and deeper waters, but are superior in quality and appearance.

RANGE, SPAWNING, ETC.

The natural range of the brook trout in the United States is from Maine to Georgia and westward through the Great Lakes region to Minnesota, and in Canada from Labrador to the Saskatchewan. Owing to its hardy nature and ability to adapt itself to new surroundings, it may be successfully transplanted into suitable streams, and has been extensively introduced into waters to which it was not native, in Michigan, Wisconsin, and Minnesota, many of the waters of the Rocky Mountains and the Pacific Coast, the Eastern States, and the creeks and rivers of the Alleghany range of mountains. With the possible exceptions of the rainbow trout and steelhead it is the hardiest member of the salmon family and will make a brave struggle for existence even with adverse surroundings. All streams can not be successfully stocked with this species; the temperature of the water must not be too high nor the flow too sluggish, although an unfavorable temperature is no serious obstacle if the speed of the current is great enough to insure a sufficient aeration of the water, or if there are creeks fed by springs flowing into the main stream to which the fish can run. The best streams are those with a gravelly bottom, clear shallow water, and a steady current, and waters to be stocked must contain a sufficient amount of natural food and suitable places for spawning.

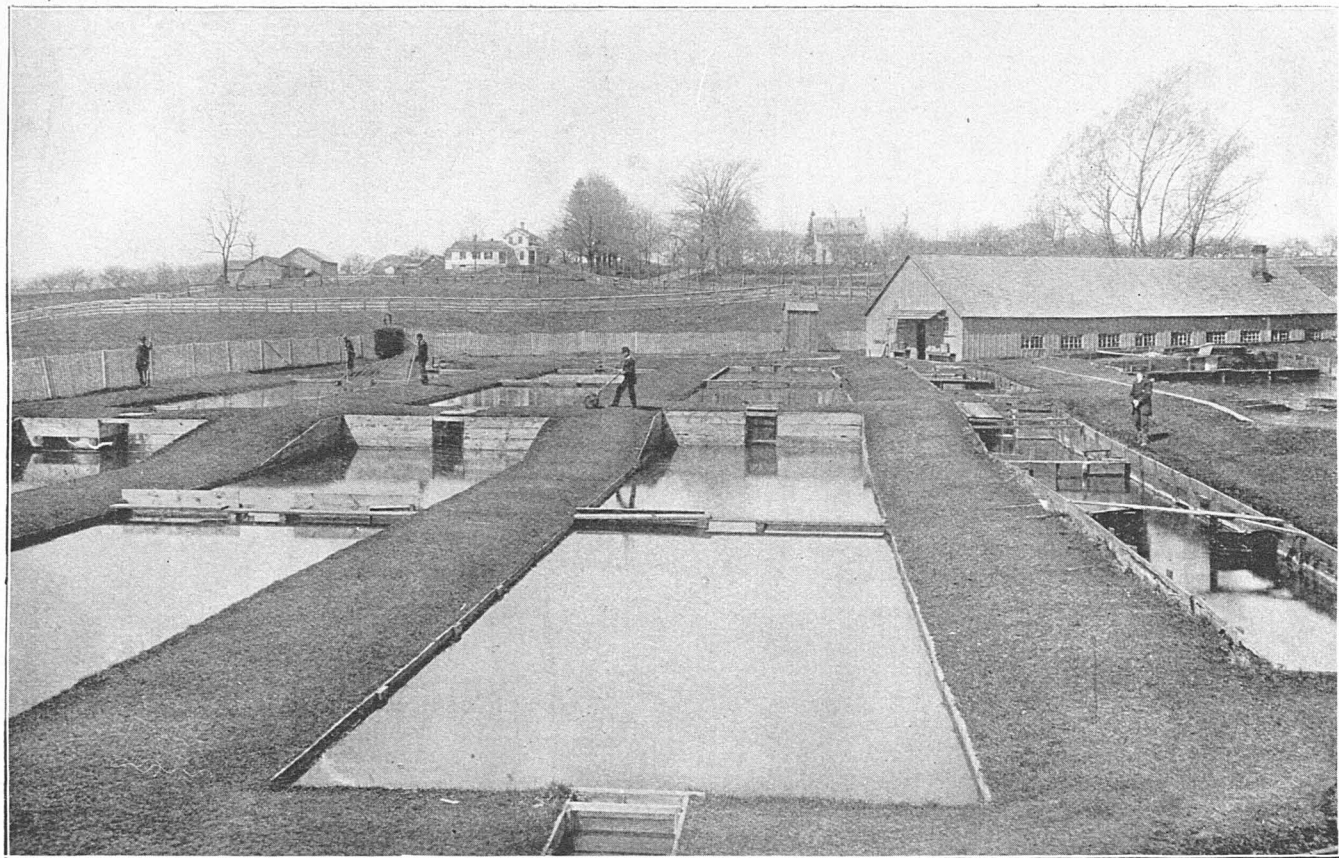

TROUT PONDS, NORTHVILLE, MICH.

The Michigan streams exemplify the practical results attained in the introduction of brook trout in new waters. The Au Sable River was long thought to be especially adapted for this species, but it abounded with grayling, and until this beautiful fish began to disappear no movement was made toward introducing the brook trout. The lumber interests of that section made it necessary to use the river for conveying logs to various points downstream, and, as the log-driving could be done only during the spring freshets, it came just at the time when the grayling were on their spawning-beds. They were driven away and the beds destroyed by the plowing of logs through the river bottom each year, till the fish gradually began to disappear. The brook trout was suggested as the proper substitute, because its spawning season is in the autumn when the river is undisturbed, and the Michigan Fish Commission began the work by planting 20,000 fry in the year 1885. Though additional plants were made from time to time, both by the Michigan and United States Commissions, no results were observed for some years, and it was thought that the work had been a failure. But the natural instinct of the fish had caused them to push from the main river into the small tributaries, where they multiplied and grew during these years till they finally crowded down into the river itself. Here they found as suitable a home as in the small streams, and their numbers gradually increased till now the stream is completely stocked.

In the autumn of 1895 a camp was established for the United States Fish Commission 9 miles below the village of Grayling for the purpose of taking spawn from wild fish. The work was confined to rod-and-line fishing until the spawning season opened, when it was found necessary to adopt some other plan, as at this time the trout refuse to feed. During the five weeks, in which the rod was used exclusively, 3,000 spawning fish were taken. A small seine was then used for capturing the fish, by hauling it at right angles to the current of the river, directly across the spawning-beds, which thickly dotted the river bottom in some places. By this method a tubful of trout at one haul was often taken, and during the period the fish were running between 8,000 and 10,000 were obtained. This illustrates the abundance in which this species is found in a river to which it has been transplanted. A conservative estimate would place the number of trout taken from this stream in the season of 1895 at 100,000, perhaps 25 per cent being rainbow trout. Other waters of the State have been successfully stocked, so that the northern half of lower Michigan now contains a network of trout streams, made by introducing this fish into waters where it was not indigenous.

In its native haunts, whether in lake or stream, the brook trout is usually found in the same clear, cold, spring water, and prefers brooks or streams flowing swiftly over gravelly bottoms. It pushes from the rivers into the small streams, seeking the headwaters, searching out

the deep pools and eddies where it can lie concealed beneath the shelter of grassy banks or logs, and see without being seen. Under artificial conditions it endures higher temperature than in its native waters, where it is seldom found in water warmer than 60° to 65°. It thrives at much higher temperature in swift, well-aerated streams than in sluggish waters.

The brook trout spawns in autumn during the falling of the water temperature. The season, which usually lasts about two months, begins earlier in northern latitudes, in the Lake Superior region in September or even August, while in New York, New England, and lower Michigan it commences about the middle of October.

As the spawning time approaches the fish push up toward the shallower waters where the female selects a spot near the bank of the stream and prepares her nest by washing out the sand with her tail and pushing aside the gravel with her nose. After forming a slightly concave depression she deposits a part of her eggs on the newly cleansed gravel, and the male—which up to this time has been playfully swimming around the nest—emits milt upon them almost simultaneously. The female then covers the eggs with the loose gravel. The spawning, impregnating, and covering are repeated continuously until the eggs are all laid. After the spawning-ground is once selected it is hard to drive the fish away, the female especially returning to the same spot at the earliest opportunity. A female has been taken from her nest and marked and then returned to the water a mile down the stream, and the next morning was found on the same bed as though nothing had happened.

The eggs vary in size, but are usually one-sixth of an inch in diameter. The number yielded by one fish depends on its size and age, yearlings usually producing from 150 to 250, two-year-olds 350 to 500, and older fish 500 to 1,500. The time necessary for developing the eggs is dependent on the temperature of the water, varying from about 125 days in water at 37° F. to about 50 days in water at 50° F.

TROUT-CULTURE IN AMERICA.

The first attempt at artificial trout-culture in America was made in Ohio in 1853 and marked success attended the efforts. Further satisfactory trials were made in 1855 and 1859 in Connecticut and New York, and in 1864 a hatchery was established in New York which became a practical success in carrying on the work on a large scale. Somewhat later the work was taken up by the State and United States governments and is now very extensively carried on in all parts of the United States.

The methods described in the following pages are those which have been found advantageous at the Northville station, and are there pursued. In addition to the eggs obtained from brood fish held in ponds at the hatchery a field station for collecting eggs from wild trout is operated on the Au Sable River.



SELECTING AND STRIPPING RIPE TROUT, NORTHVILLE, MICH.

THE FIELD STATION.

For the egg-collecting station a point was selected on a tributary of the Au Sable, flowing about 1,000 gallons per minute, near where it empties into the river. A dam was thrown across the stream and 100 feet above a screen was built to prevent the fish from escaping in that direction. The dam is simply constructed by banking up mud, sand, and turf, and has a frame sluiceway 3 feet long, 2 feet wide, and 2 feet deep. In the sluiceway is inserted a double screen of $\frac{1}{4}$ -inch mesh wire netting, two screens being necessary to keep the overflow clear and reduce as low as possible any loss of fish through this outlet. The inclosure accommodates about 10,000 fish. For holding the eggs two pairs of troughs are placed on standards driven into the bed of the stream, with a passage between them wide enough to admit a man. Fish are obtained with rod and line, until they begin to run from the deep pools upon the spawning-grounds, when much better results are obtained with nets. With an ordinary seine at the approach of the spawning season, the fish can be taken in large numbers from their spawning-beds. As the season advances and too many fish are caught that have already spawned, operations are suspended.

The water is received through two 1-inch orifices in a bulkhead about 9 feet long, situated at the head of these troughs and fed by a roughly-constructed raceway leading from a small spring about 6 rods distant on the hillside. The water from each of the openings feeds two troughs, so placed that the lower end of the upper one rests upon the head of the other, thus creating a fall of nearly the height of the troughs. Each trough is 14 feet long, 5 inches deep, and consists of a double row of boxes, each box 17 inches long, 15 inches broad, and 2 inches deep, giving a capacity of from 8,000 to 10,000 eggs.

As soon as ripe fish are found among those caught on the spawning-beds, the pond is hauled with a seine and the fish are looked over twice a week until all the eggs are taken. When the season is fairly opened the spawn may be taken from most of the fish immediately after they are caught, thus obviating the difficulty of transferring them from the point of capture to the pond, in some cases a distance of 3 or 4 miles.

TAKING THE SPAWN—DRY PROCESS.

A good spawn-taker can tell at a glance if a female is ripe, and only in such condition should an attempt be made to take her eggs. After the ripe males and females are placed in separate tubs or buckets, the spawn-taker is ready to take the eggs, the implements necessary being a feather and an ordinary milk-pan coated with asphaltum paint on the inside to prevent rust. The pan is first dipped in water and allowed to drain, leaving only the water that clings to the inside. Taking a female from the tub she is held as quietly as possible till all struggles cease, and then pressing gently with the thumb and forefinger a little above the ventral fins, the hand is passed down the belly to the oviduct,

and the operation repeated till all the eggs are extruded. The eggs are immediately impregnated with milt, which is obtained from the male in similar manner, except that more force is necessary and the pressure is made at a point about midway between the ventral and anal fins.

The contents of the pan are next lightly stirred with a feather to insure impregnation of all the eggs possible. They now present a milky appearance and are washed in as many changes of water as is necessary to thoroughly cleanse them from the milt and other refuse, when the pan, left half filled with fresh water, is placed in running water to keep the eggs at a low temperature. After from 30 to 60 minutes, according to the temperature of the water, the separation of the eggs ensues.

In the work on the Au Sable River, the eggs, after separating, are laid on gravel placed $\frac{1}{2}$ inch deep in the boxes of the troughs. Here they remain till the eye-spots begin to appear, when they are prepared for shipment. During this interval of about thirty days the principal care consists in sorting out bad eggs, and, with a feather, gently changing the position of good ones to prevent sediment from collecting on them.

SHIPPING GREEN EGGS.

Green eggs can be safely moved at any time up to and including the eighth day. They are shipped from the field station to the hatchery in cubical boxes constructed from $\frac{1}{2}$ -inch pine lumber, just large enough to admit, with a surrounding air-space of $\frac{1}{2}$ inch, 19 canton-flannel trays, 18 inches square on the inside, the frames of which are made from $\frac{3}{8}$ -inch square white pine. The eggs are drawn by means of a siphon from the gravel boxes into a tub or bucket which has been half filled with water to prevent them from injury. Using a graduated dipper for the purpose of ascertaining approximately the number of eggs necessary to make them about two deep on the tray, the packer pours them upon the flannel and spreads them as evenly as possible with a feather. The tray is then placed in the box and the operation repeated until eighteen trays are filled with eggs. The nineteenth, or top tray, is usually left empty, but if the weather is very warm it is filled with fine ice. The cover is then fastened down, the box marked, and the eggs are ready for shipment to the hatchery.

THE HATCHING APPARATUS.

After a period of about thirty days on the gravel, the eggs are taken up and placed in the Clark hatching-box, for here they may be held without any appreciable loss through the escape of fish when hatching. This apparatus as used at Northville is arranged as follows: A tank 15 feet long, with a partition running its entire length, is so placed that its lower end rests upon the upper end of a similar one 13 feet long, which differs from the upper one only in that it contains two boxes less. Nine partitions, placed crosswise of the tank, form, with the lengthwise partitions, a double row of eight compartments, each of which is $19\frac{1}{2}$

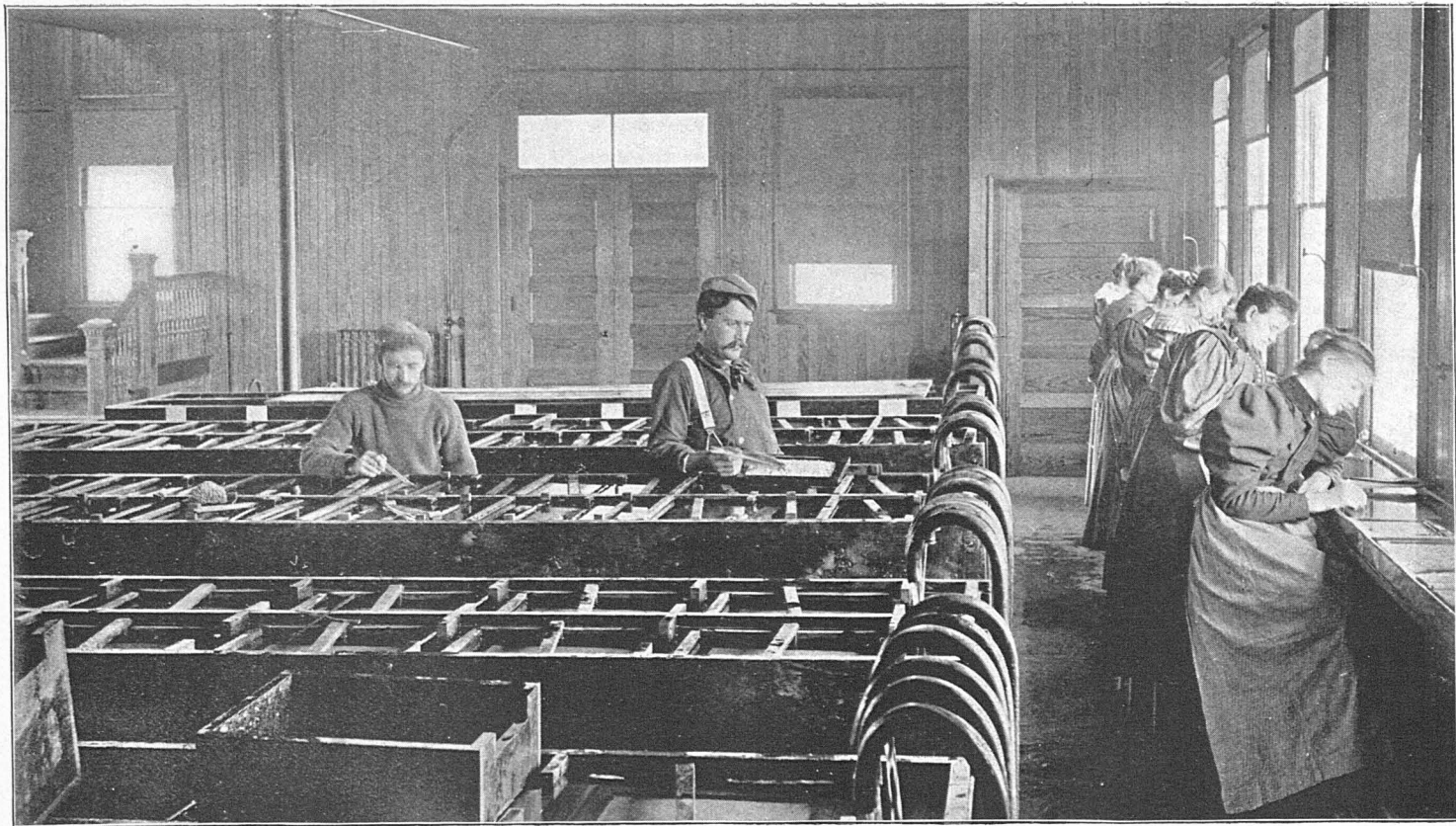

INTERIOR VIEW OF NORTHVILLE HATCHERY: CLARK BOXES IN FOREGROUND; CLARK-WILLIAMSON BOXES IN BACKGROUND; GIRLS PICKING EGGS AT THE RIGHT.

inches long and $15\frac{1}{2}$ inches wide, and is provided with a waste-water channel or sluiceway leading into the next compartment. In these compartments are placed the hatching-boxes proper.

The Clark box is 18 inches long, 14 inches wide, and $9\frac{1}{2}$ inches deep, and is made from $\frac{3}{4}$ -inch dressed whitewood lumber. On its under side the box is provided with feet, $1\frac{1}{2}$ inches square and $\frac{3}{8}$ inch thick, to allow a free circulation of water under it and to prevent it from resting upon any sediment or refuse that may be deposited on the bottom of the tank; and on the inside in each bottom corner is fastened a block, $\frac{3}{8}$ inch thick by $1\frac{1}{2}$ inches square, to support the trays. Five circular openings, $\frac{7}{8}$ inch in diameter, permit the escape of water from the box. A slot is cut in one end of the box so that water from the compartment above can not flow into the one below without falling into and passing through this box. Upon the feet or risers inside the box rest 9 trays, made of perforated zinc or fine wire netting, tacked upon a frame 16 inches long and 12 inches wide. This frame is made from $\frac{3}{4}$ -inch pine, $1\frac{1}{2}$ inches wide. The trays are placed one upon the other in the box, the end which contains the slot fitting snugly against the upper end of the compartment, in which is fitted a tin overflow. The whole is held in place by a crossbar or binder, which fits in $\frac{3}{8}$ -inch grooves cut in both sides of the tank. The binder, resting upon the box, keeps it from rising in the water, and is provided with feet so placed as to prevent the trays from floating in the box itself.

Upon the arrival of the green eggs at the hatchery they are transferred from the flannel trays to a large galvanized iron pan, and thence to the Clark hatching-boxes. The eggs are measured with a glass graduate and 5,000 placed upon each tray, the ninth or top tray being used only as a cover. The eggs from domesticated brook trout measure 350 to 450 per fluid ounce, depending on the age of the fish. Eggs from wild trout collected in the Au Sable River measure 450 to the fluid ounce.

CARE OF THE EGGS.

At intervals of from three to six days during the period of incubation, in order to remove the bad eggs, the trays are taken from the boxes and placed in a shallow picking-trough through which a stream of not more than 3 gallons per minute is flowing. This trough is only wide enough to allow perfect freedom in handling the trays when putting them into or removing them from it, and only of sufficient depth to allow the eggs to be fairly covered. Nailed to the bottom on each side is a $\frac{1}{2}$ -inch strip, $1\frac{1}{2}$ inches wide, and running the entire length of the trough. These strips permit the free passage of water beneath the trays, as otherwise the water would flow over the tops and a great many eggs would be lost. The bad eggs are removed with a pair of tweezers, the labor of sorting being usually performed by girls, who in time become so expert that one girl will often remove 100 bad eggs per minute.

After the incubation has reached a stage where the fish are beginning to break their shells, the hatching-box is taken out and reversed, the open end being fixed snugly against the lower wall of the compartment. The closed end of the box being thus placed upstream, the water is prevented from entering except through its former exit, the holes in the bottom of the box, and is thus forced up through the box, with an exit at the top which prevents the sacs of the hatching fish from being forced, by pressure from above, down through the screen, as would be the case if the box were left in its former position.

When the process of hatching is nearly completed the trays are removed and emptied into a large pan filled with water, where the dead shells and other refuse, being of low specific gravity, rise to the top and can be easily poured off. This is called washing the fish. The fish are then replaced upon the trays and returned to the hatching-boxes, where they remain until the food-sac is nearly absorbed, a period of from 25 to 40 days, according as the temperature varies from 50° to 38° F.

The young fry, deprived of their food supply by the absorption of this sac, must soon be placed where they can get their sustenance elsewhere. They may be planted in waters suitable to their nature, or reared for breeding or other purposes at the station.

PLANTING THE FRY.

In their natural state, as soon as the weight of the food-sac has diminished by absorption enough to permit their rising, the fish begin to take food, and by the time the sac is entirely gone they are probably taking it regularly. When very young fry are transferred to outside waters where there is natural food only, it should be done 8 or 10 days before the sac is entirely absorbed, for, if delayed till after the sac disappears, many will die before they become accustomed to finding food in their new home.

Brook-trout fry are usually transported in ordinary round-shouldered cans of 10 gallons capacity, the number of fish per can depending entirely upon the distance they are to be carried and the facilities for taking care of them en route, such as opportunities for changing the water, supplying fresh ice, etc. For a short trip of from 5 to 10 hours duration, between 4,000 and 5,000 are carried in each can, but where they are to be on the road from 1 to 5 days, it is hardly safe to attempt carrying more than 2,500. The United States Fish Commission distributes fry by means of its cars, built especially for the purpose, in which either running water is kept upon them or fresh air introduced into the water to make it life-sustaining. Small shipments are made by a special messenger in a baggage car, the railway companies usually offering every available opportunity for changing water, etc. The fish, upon arrival at the railway point nearest their destination, are carried thence by wagon to the stream where they are to be planted, by distributing them in small lots in different places where there is shallow water and a good bottom.

REARING AND FEEDING.

If the fry are to be reared for breeding, one week before the food-sac is absorbed they are changed from the trays to a large pan and removed to the rearing-troughs. Gravel should not be used in these troughs, as the unconsumed food works down into it and, becoming fungussed there, causes a greater spread of disease and increases the labor of caring for the fish.

The time to begin feeding the fry is readily ascertained by trial. If they rise to minute particles of food thrown upon the water, they are then ready for regular feeding. The time and frequency of feeding young fish, the kind of food, and the manner of feeding them, are of the greatest importance. Liver gives better results than any artificial food, and its preparation is very simple. Beef livers are ground by a meat-chopper and then strained through a fine-meshed screen, a thick pudding being made by the addition of water. A small portion, only such an amount as the fish will readily eat at a time, is spread upon the surface of the water with a feather, and they are fed as often as six or eight times per day until they become used to the new diet. As they grow older the quantity of food may be increased but the fish are fed less frequently. At this stage the young fish have such a precarious hold upon life that too much attention can not be given to their care. Not more than 20,000 can be held with success in a feeding or rearing trough, and a regular stated supply of water is kept flowing through to prevent disease, and the fish are properly thinned out in order to prevent loss by suffocation when they increase in size. About 30 gallons of water per minute are sufficient for 20,000 fry, though this quantity is increased as the fish grow stronger and are able to breast a heavier current.

In the spring season, when the water begins to grow warm, the fish require more room than the feeding-troughs afford, and it is then necessary to transfer them to ponds. The Northville rearing-ponds are 5 feet by 20 feet, made from 2-inch pine boards and provided with a gravel bottom. A pond of this size accommodates from 10,000 to 20,000 fry till the middle of the summer, when the number is reduced to as low as 5,000. It is advisable to place not more than 5,000 in the pond at first to avoid the labor of reducing the number of fish at different times, and also because crowding into too small a space retards their growth.

At first the fish require coaxing to induce them to eat, as the change to their new abode has frightened them, and a great deal of patience is necessary in their treatment. They are fed at regular intervals three times per day. As their appetites are poor for the first few days, the liver will fall to the bottom and foul the pond, if great care is not exercised, and three fourths of an hour is not too long for feeding 5,000 fry. The time occupied in feeding is diminished and the amount of food increased according to the judgment of the fish-culturist; but their appetites should never be completely satisfied.

By early winter they will have grown to a length of from 3 to 6 inches, necessitating a change to a larger pond. The Northville breeding-ponds are 20 by 75 feet, and are constructed in the same manner as the rearing-ponds. One of these larger ponds accommodates 10,000 yearlings, 5,000 two-year-olds, and about 3,000 fish from three to five years old. By the time the fish are three years old and over, less care is required in the preparation of their food, as the liver may be given to them in pieces half an inch in diameter.

PACKING EYED EGGS FOR SHIPMENT.

Eyed eggs prepared for shipment in the following manner have been sent from Northville to all parts of the United States with practically no loss: The trays upon which the eggs are to be shipped are made from the same materials as those upon which green eggs are carried, but are usually much smaller. Fewer eggs are placed upon a given surface than is the case with green eggs. For example, 10 trays, 12 inches by 12 inches, will carry 50,000 eggs; 8 trays, 10 inches by 10 inches, 32,000 eggs; and 5 trays, 8 inches by 8 inches, 12,500 eggs; or 5,000, 4,000, and 2,500 eggs per tray, respectively.

The trays are allowed to stand in cold water till thoroughly soaked, and are then drained off and taken to the packing-room. After the dead eggs have been removed from a box, the trays are taken out, drained, and removed to the packing-room. A $\frac{3}{4}$ -inch wooden frame, made to fit the inside of the canton-flannel tray, is then inserted, the eggs are carefully brushed with a feather from the wire trays and spread as evenly as possible upon the flannel. The eggs have been previously measured at the time when they were removed from the gravel to the hatching-box, so the number to be placed upon each tray can be easily determined. After the eggs are spread upon the flannel, the inside wooden frame is taken out, leaving a $\frac{3}{4}$ inch margin around the inside of the tray. A square of mosquito netting large enough to lap over on all sides of the tray is laid upon the eggs and tucked down firmly along the inside. Sphagnum moss is scattered to a depth of about $\frac{3}{4}$ inch upon this netting. The moss is prepared by removing sticks and other foreign matter; it is soaked in water a short time and then run through a clothes-wringer. In spreading it upon the netting the moss is picked apart and made as light and fluffy as possible, to give the eggs plenty of oxygen.

When the required number of flannel trays are packed they are placed one upon another and cleated together on all sides, with boards at the bottom and top. This crate is usually placed, if possible, where the temperature of the air is below freezing, so that the moss may be slightly frosted before the crate is put in the shipping-case.

A case is made large enough to allow a 4-inch space above, below, and around all sides of the crate when it is placed in position. Its bottom is filled with fine shavings, 4 inches deep, and the crate placed upon them as nearly as possible in the center of the case. Shavings



REMOVING GREEN EGGS FROM SHIPPING-TRAYS, NORTHVILLE.

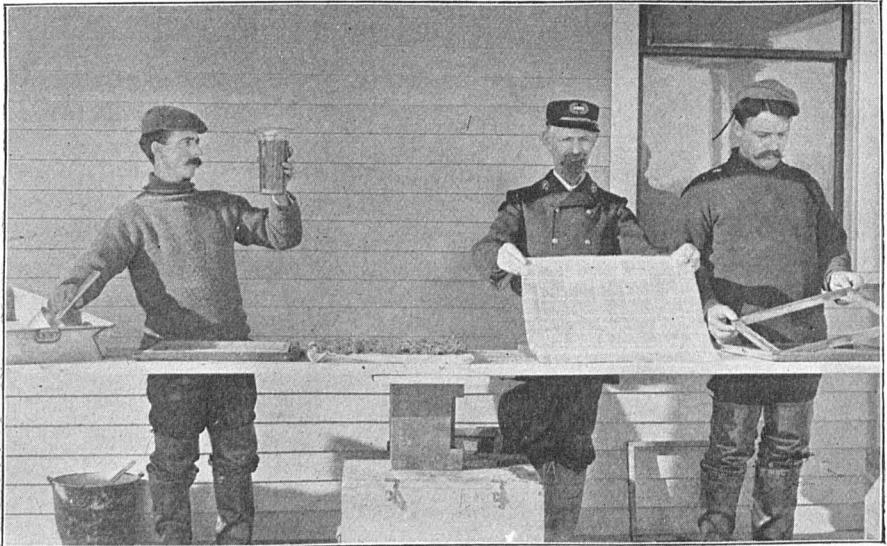

PACKING EYED EGGS, NORTHVILLE.

are packed tightly around the crate, a few being thrown in and pounded down securely before more are added. This must be well done, as the shavings are the only means of preventing a change in the position of the crate. The top of the crate is then covered with closely packed shavings and the cover of the case screwed on. By means of rope or iron handles the case may now be moved about with ease, and is ready for shipment.

REFRIGERATOR BOX FOR SHIPMENTS ABROAD.

A double box is used for this purpose. The inside one is $2\frac{1}{2}$ inches larger on all sides than the crate of trays, and the outside one large enough to make a 5-inch space on all sides when the smaller box is placed within it. The trays of eggs are prepared as in ordinary shipments, and when crated are placed in the smaller box upon a frame which is constructed from a $\frac{1}{2}$ -inch strip, $2\frac{1}{2}$ inches wide, tacked at right angles to the inside and bottom of this box. In the chamber thus formed between the crate and the box is packed finely chopped ice, an exit for the water resulting from its melting being provided by a half dozen openings in the bottom of the box. This box is now packed according to the same plan as that followed with the shipments for a short distance. Where there is an opportunity, it is well to have the case unpacked en route and new ice added.

Eggs have been sent in this manner to England, Mexico, New Zealand, Japan, and South America.

DISEASES.

Brook-trout fry are subject to diseases and epidemics, and extreme measures are often necessary to eradicate these evils. Many experiments have been made to discover some method of treatment that will prevent the introduction of disease. At Northville the troughs are flushed every day for five minutes with an extra supply of water, and twice a week they are thoroughly cleansed with a stiff brush or sponge. The fry are then treated with a weak solution of salt, which is allowed to remain until the fish show signs of discomfort, when the troughs are flushed for a few minutes and the water reduced to its regular flow. As the fish increase in size they may be thinned out in the trough and also at the first indication of disease.

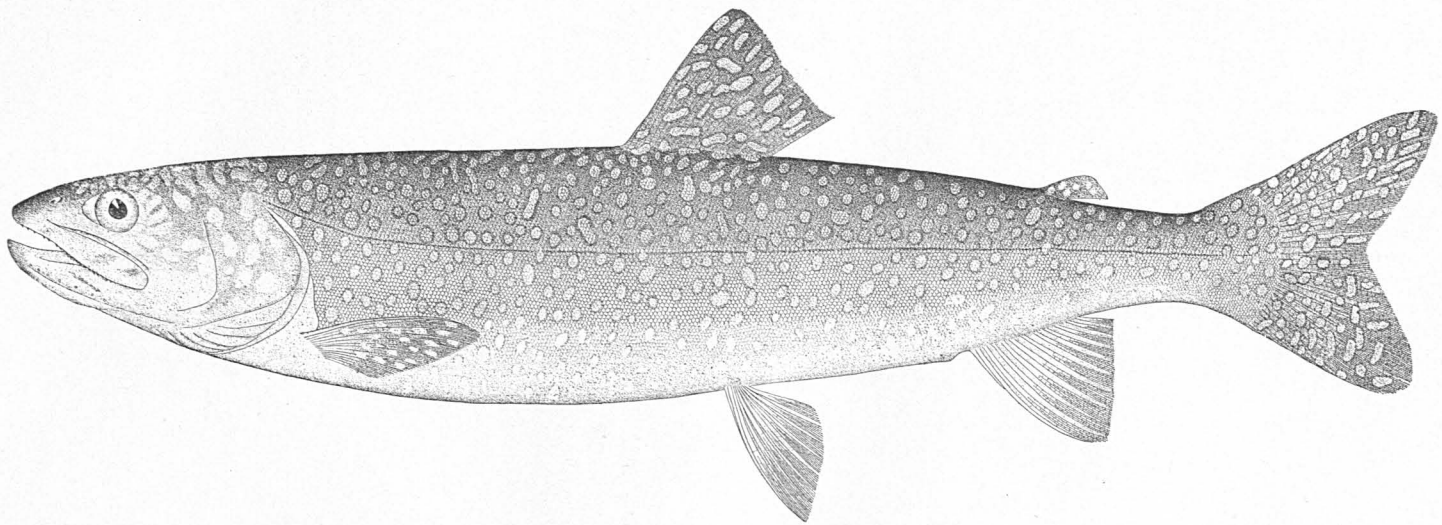

CRISTIVOMER NAMAYCUSH. *Lake Trout.*

THE LAKE TROUT.

DESCRIPTION OF THE FISH.

This handsome species (*Cristivomer namaycush*), the largest of the trouts, is classed with the charrs. It has an elongated body, the length being about $4\frac{1}{2}$ times the depth. The head is large, flat above, and about as long as the body is deep. The mouth is large; the maxillary bone extends beyond the eye and is half the length of the head; the jaws have strong teeth. A peculiarity of the vomerine bone distinguishes this fish from the genus *Salvelinus*; it has a crest provided with teeth extending backward from the shaft of the bone. On the hyoid bone the teeth are in a cardiform band. The eye, placed near the top of the head, is contained about $4\frac{1}{2}$ times in length of head. The caudal fin is well forked. Both the dorsal and anal fins contain 9 to 11 rays. In the straight lateral line there are about 200 scales. Branchiostegals 11 or 12.

The coloration is quite variable in fish from different localities. The general color is usually dark gray. The body, head, and fins are covered with small discrete rounded spots, usually of a pale color, but often tinged with reddish. On the back and top of head there are fine vermiculations, as in the brook trout. Examples from some lakes of Maine and eastern Canada are nearly black, and Alaskan examples are often very dark; others are quite pale.

That variety of the lake trout known as the siscowet (*Cristivomer namaycush siscowet*), found only in deep water in Lake Superior, is shorter and paler than the typical fish and has weaker teeth and a shorter head; it is, however, chiefly characterized by an excessive fatness, which greatly reduces its food value.

The present chapter is devoted to trout of the Great Lakes and the methods of propagation employed at the station of the United States Fish Commission at Northville, Michigan.

RANGE, FOOD, ETC.

The lake trout is found throughout the chain of the Great Lakes, and the inland lakes of northern New York, New Hampshire, and Maine; the headwaters of Columbia and Fraser Rivers, streams of Vancouver Island, and even waters within the Arctic Circle are said to contain this species. With the exception of the whitefishes, it is perhaps the most numerous food-fish of the Great Lakes, and formerly none exceeded it in weight except the sturgeon. Instances are cited by fishermen and others of lake trout weighing as high as 125 pounds, and its average weight has been given at from 20 to 30 pounds, but of late they are rarely found exceeding 18 or 20 pounds. Possibly, if unmolested by

man, they might again reach the enormous weight of early citations, their sluggish movements and voracity being conducive to such a result.

The nature of their environments has a decided influence on the characteristics of this species; the temperature of the water, food, and character of bottom entirely changing the marking and peculiarities of these fish in their various habitats.

Until recently it was commonly thought that the principal food of the lake trout was the young whitefish, and for this reason the fishermen of the lakes were generally unfavorable to its artificial propagation. The error of that belief, however, is now generally conceded, though no doubt quite a number of young whitefish become food for trout during each season. But as the habits of the lake trout take it to deep water immediately after spawning, while the young whitefish remain in shallows, the few which are destroyed in this manner are either stragglers from shoal to deep water or taken by trout aimlessly wandering from their natural range. The lake trout is an omnivorous feeder and has a ravenous appetite. It greedily devours all fishes possessing fins of flexible character, and jackknives, corncocks, and other articles equally indigestible have been found in its stomach.

The spawn and fry of lake trout suffer from the same enemies as the young of all fishes, but the mature fish are too formidable for other species to prey upon. They are troubled with a few parasites. Occasionally individuals, very thin in flesh and sickly-looking, known as "racers" by fishermen, are found swimming near the surface; no sufficient cause has been discovered for this condition, as they are no more afflicted with parasites than healthy fish.

IMPORTANCE AND ABUNDANCE.

The trout fisheries of the Great Lakes are second in importance commercially, the whitefish ranking first. At one time trout were so plentiful that they did not command a price at all proportionate to their edible qualities, but as the fishing continued the catches decreased, until about the year 1886 the market price of trout became equal to that of its more delicate rival. At this time it became evident to the Federal and State governments, as well as to those dependent upon this industry for a livelihood, that decisive steps ought to be taken toward providing against the extermination of this valuable food-fish. Artificial hatching was commenced that year with the object of restocking the Great Lakes. The work progressed only in a limited way up to 1892, when the output of both the United States and Michigan Fish Commissions reached something like its present proportions. During the season of 1895 the United States Fish Commission station at Northville secured over 11,000,000 lake-trout eggs. As indicative of the success attending the plants of lake trout, it may be remarked that for a short period during the season of 1896 the fishing-boats, which had been working to their fullest capacity, ceased operations, the market being glutted and the remuneration not being commensurate with the labor, hardship, and capital invested.

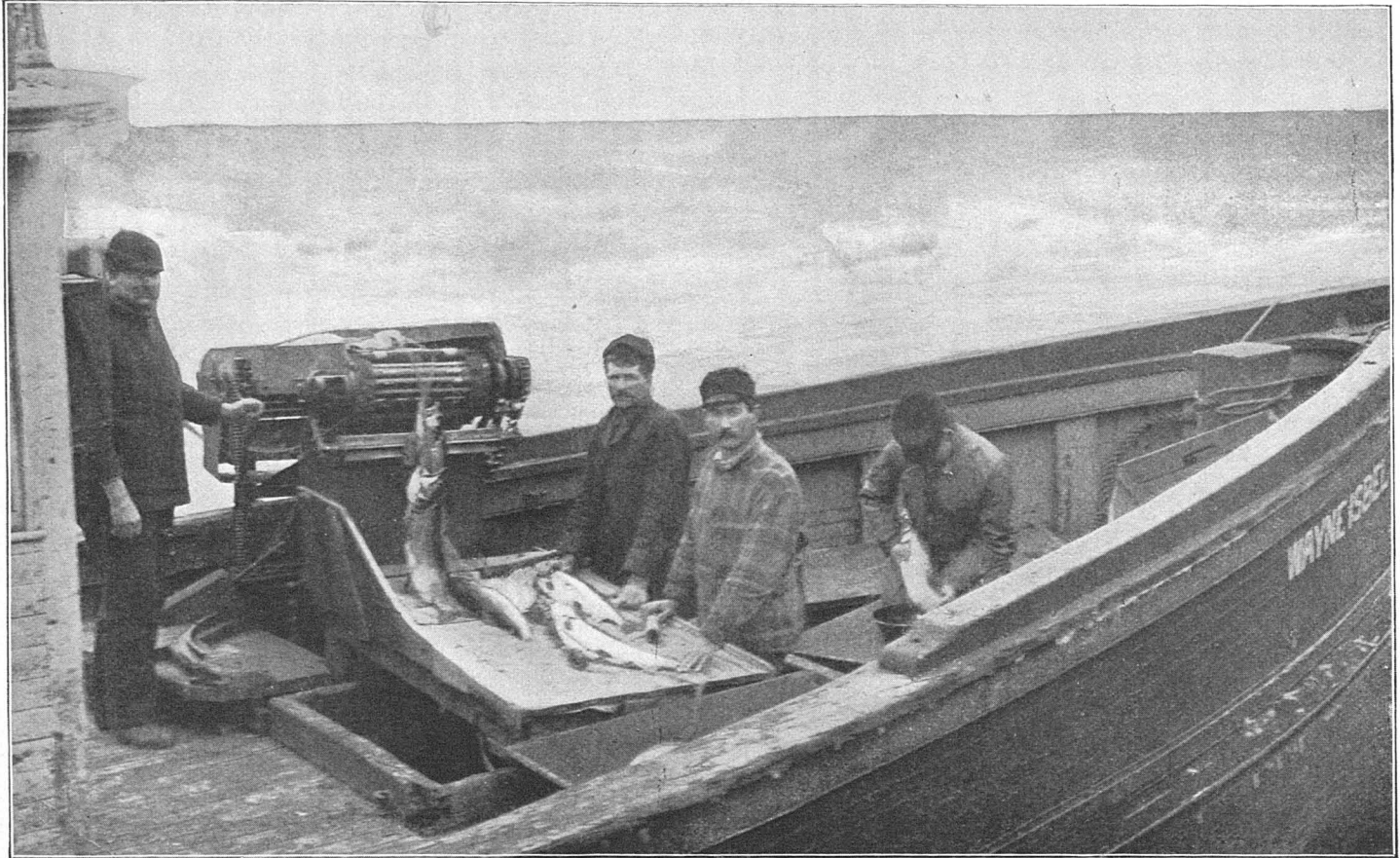

COLLECTING LAKE-TROUT SPAWN ON FISHING STEAMER IN LAKE MICHIGAN.

The method of capture is by gill nets, pound nets, hook and line, and in winter by spearing through the ice. The majority, however, are taken from gill nets operated by steam tugs. These boats are fitted out with the most approved appliances of their trade and have quarters on board for the men employed, usually a crew of 8 or 10. Some of the tugs carry 5 or 6 miles of nets and catch in one lift from 1,000 pounds to 4 or 5 tons of trout. Fishing is done from the time the ice breaks up in the spring until late in the fall or early winter, the work ceasing only when the weather and ice no longer permit operations. In some localities the water becomes so warm during summer as to be detrimental to the nets, and consequently at such points there is a lull in the work for a few weeks. Lake trout spawn on the reefs and live in deep water during the remaining time, and their migratory habits govern the movements of the tugs, the fishermen necessarily moving from one point to another. The small gill-net boats, carrying sails and handling a few hundred feet of nets, confine their operations to more shallow water and fish only during the spawning season. At Detour, Lake Huron; at some points in Lake Superior, and on the north shore of Lake Michigan pound nets are in use, but usually these nets are not used to any great extent for the capture of lake trout.

NATURAL SPAWNING.

Spawning commences the last of September in Lake Superior and later in the lower lakes, since the water does not become sufficiently cool here as early as in the headwaters. In Lakes Huron and Michigan the height of the season is in the early part of November, and spawning continues to the first of December. The spawning-grounds are on the reefs of "honeycombed" rocks, 10 to 15 miles from shore, and during the reproductive period vast numbers of fish visit these places, spawning in a depth of from 1 to 20 fathoms. Owing to the great depth of water, the shyness of the fish, and the severity of the weather at this time, nothing definite has been determined as to the fish's maneuvers while spawning. The supposition is that the female lies over an indentation of the rocks and allows her eggs to settle into the "honeycomb" cavities; fragments of the rock with the cavities filled with eggs having been hauled in by fishermen when lifting their nets. No doubt the general characteristics of the *Salmonidæ* are carried out by the lake trout as far as the conditions in which they exist permit.

An instance has been known of a Mackinaw trout of 24 pounds weight containing 14,943 eggs; but not over 5,000 or 6,000 eggs are commonly found, and 1,000 eggs to the pound of fish may be accepted as a general rule, after the trout have attained maturity, at three years of age.

A much smaller variety, called the shoal trout, is found in Lake Huron in the vicinity of Alpena, and in Lake Michigan near Charlevoix and Northport, but its weight compared with its length is greater than that of the true Mackinaw trout, and the markings and appearance of the two also differ. The shoal trout spawns in September, about a

month earlier than the lake trout, on a cobble, bowlder, or gravel bottom, and in from 2 to 8 feet of water.

OBTAINING THE EGGS.

During the spawning season men are employed by the different lake-trout hatcheries to accompany the tugs to their fishing-grounds and strip the ripe fish as they are taken from the nets. These "spawn-takers," or "strippers," must possess strong constitutions to withstand the many hardships to which they are subjected. Where very extensive nets are operated by a boat and fishing is exceptionally good, two men are detailed to the same ground, one as spawn-taker, the other as helper. Pans, pails, and dippers are taken on board and made ready by the time the nets are reached. As the net is lifted the men disentangle the trout and throw them on deck, where the spawn-takers sort them over, taking the eggs from ripe females and impregnating them with milt from the males. During very severe weather the fish are thrown into the hold instead of on deck and the work is done there.

The manner of taking the eggs is similar to that used in taking spawn from other trouts and salmon. First, the female is taken and the eggs, if mature, are gently stripped into an ordinary milk-pan and then impregnated with milt from the male. This operation is repeated until the pan is about half filled, when the eggs are "washed up" and poured into a 5-gallon pail. The "washing-up" process is performed by filling the pans with water and then allowing it to run off, repeating the same until the water which is poured off no longer appears milky; as the specific gravity of the eggs prevents their rising to the surface this can be done without loss if ordinary care is exercised. The pans are refilled and emptied in the same manner until the pail is half or three-fourths full, when it will contain about 75,000 eggs; other pails or buckets are brought into use as often as necessary. To keep the eggs from dying, the water is changed in the large pails every hour until the eggs are taken from the boat and transferred to flannel trays or floating-boxes. All pans, pails, and other metallic apparatus are coated with asphaltum paint to prevent rusting, as rust is fatal to the eggs.

When the weather is so cold that there is any chance of eggs freezing to the pan, two pans are sometimes used. The outside one is partly filled with water, upon which floats the pan that is to receive the eggs as they are stripped. The pan of water protects that part of the inside pan where the eggs rest and in that way their temperature is kept above the freezing-point.

SHIPPING EGGS TO THE HATCHERY.

When spawn-takers are operating at a distance the eggs are held at field stations located at convenient points, whence they are sent to the hatching-house as soon as possible, but if the stations are at isolated points on the lakes it is often necessary to hold the eggs for several days, and occasionally weeks, before means of transportation can be obtained. In such a case the eggs are held in floating-boxes, which are made 2½ feet by 1½ feet by 1 foot, with the ends rounded up about 6

inches; the sides and ends are 1-inch pine and the bottoms $\frac{1}{2}$ inch-mesh iron wire cloth, which is continued over the rounded ends. Cleats are nailed on the sides, one end somewhat lower than the other, to give the box a tilt when placed in water. Each box carries safely about 180,000 eggs, and when it is filled is anchored either in running water or in a sheltered cove of the lake. In the former case a current of water is kept passing through the box, while in the latter the eggs are given a slight motion by the action of the waves upon the surface of the water.

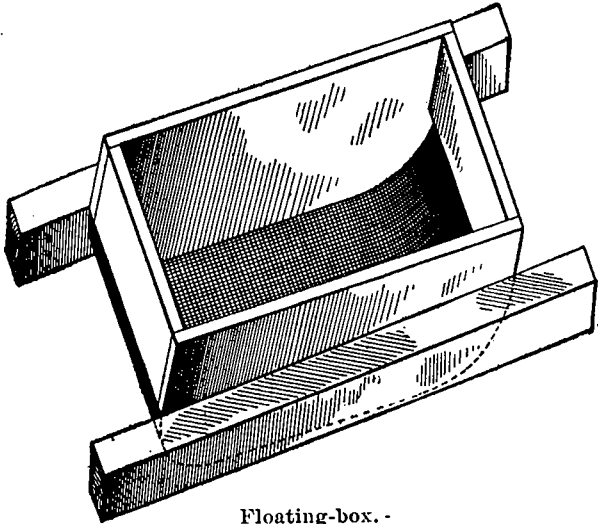

Floating-box. -

When eggs held in floating-boxes are to be shipped they are dipped into pails and taken to a place arranged for packing them, located at no great distance away, where a table upon which to place the trays may be improvised from any material at hand.

The trays for packing the eggs are constructed by making a frame of $\frac{3}{4}$ -inch square pine, 18 inches square, inside measurement, with white canton flannel tacked on one side. A case to contain the trays is made of $\frac{7}{8}$ -inch pine, large enough to hold 19 of these trays one over the other, allowing for a surrounding air-space of half an inch. Half-inch cleats are nailed on the bottom and at the corners of the box on the inside, so that the trays are securely held in position. A hinged door is at the top, handles are at the sides, and the whole is painted and of neat appearance.

For transferring the eggs from pail to tray a graduated dipper is used, which has a capacity of about 10,000 eggs, the number usually placed upon each tray. Thus, in a case containing 18 trays 180,000 eggs may be stored. A dipperful is placed upon each tray. The canton flannel holds water for some time, and if a little is poured upon the eggs, which are at first bunched in the center, they settle and spread, and by a slight dexterous movement, acquired by practice, are evenly divided over the tray. Ten thousand eggs on a surface 18 inches by 18 inches are about two deep, and if kept at the proper temperature and handled carefully they may be carried a long distance. After the eggs

are spread upon the tray it must be drained before being placed in the case, for eggs slightly moistened will live for a longer time in open air of the right temperature than in dead water. The tray is easily drained by slightly tipping it, so that the water will run out at the edges where the flannel is tacked on the frame. The trays are then placed in the case, eighteen filled, the top one empty.

If the case is to pass through a varied air temperature, moss is packed in the space between the trays of eggs and the sides of the shipping-case for protection against abrupt changes in the weather.

When necessary to hold eggs on the trays for any length of time, as is often the case, each tray must be taken out and sprinkled with water at least every 24 hours. When they are held for a longer period than 4 or 5 days they must be taken from the trays and placed in a tub of water and there washed in the same manner as described in taking spawn. When adding water, care is taken that it does not strike the eggs with such force as to injure them, the dipper either being held down in the eggs or the water poured against the side of the tub a little above the surface of the spawn, which gives them a steady whirling motion and at the same time does them no injury.

The manner of transferring eggs from trays to a tub is very simple. After filling the tub with water to about a third of its capacity, the tray is placed in water at an angle of about 45° with its surface. Most of the eggs will slide down this incline into the tub, and what few remain may be washed down by pouring a little water on the uppermost side of the tray. After the eggs have been given a good washing they are replaced on the trays and returned to the cases, as described above.

The eggs are shipped in charge of a messenger, if possible, to see that the cases are not roughly handled or tilted and the contents jarred or bunched while being placed in the baggage car. While on the road they must be kept in the coolest place on the car, providing that the temperature is not below 28° or 30° .

It can be readily seen that the percentage of lake-trout eggs hatched can not be so large as with other species of trout. The rolling and pitching of the tugs and other boats upon which the spawn-taker is operating prevents the eggs from separating naturally. The time during which this should take place would be, approximately, within the first 30 minutes after they are taken, and as the boats are out from 5 to 24 hours or longer, when shore is reached the time is long past when quiet is of any value. Besides, the temperature often falls far below freezing, and all the precautions that can be taken will not prevent a considerable percentage of the eggs becoming chilled, although there may be no ill effects discovered until after they reach the hatchery. Other losses often occur through accident and the carelessness of those handling the cases while en route to the hatchery. Taking everything into consideration, it may be considered excellent work if an average of 70 per cent of eyed eggs and fry is turned out. In exceptional cases as high as 90 per cent have been hatched.

THE HATCHERY.

The hatching-trough or tank in use at Northville combines the principles of both the Clark and the Williamson hatching apparatus and is therefore called the Clark-Williamson hatching-box. It possesses more advantages than any other in use for the development of a large number of eggs; a thorough circulation is obtained for thousands, the apparatus is simple, and the eggs may be readily handled for picking, cleaning, etc. It consists of a trough of any length according to the number of fry to be held, $18\frac{3}{4}$ inches wide inside and 1 foot deep, with partitions to divide it into compartments, and is constructed as follows: Only the best $1\frac{1}{2}$ -inch pine is used, all planks containing knots, heavy pitch, etc., being rejected, and the sides and ends are each made of but one piece of lumber. The bottom is made first, the strips of different widths plowed and tongued securely, and all joints laid in white lead.

Referring to figs. 1 and 3, page 110, three-quarters of an inch down from the top of the sides is a $\frac{3}{8}$ -inch groove (A) running the entire length of the trough. The partitions, dividing the trough into compartments, $18\frac{3}{4}$ inches by $9\frac{3}{4}$ inches by 12 inches, are mortised $\frac{1}{4}$ inch in the sides; the first and each alternate partition (B) is fixed $\frac{1}{2}$ inch from the bottom of the trough to allow the water to pass under it; the second and each alternate partition (C) is mortised into the bottom, and at the top is cut out so as to leave a space $14\frac{3}{4}$ inches long by $1\frac{1}{2}$ inches deep for the water to pass over. In the bottom of the boxes thus formed a $\frac{1}{2}$ -inch strip (D) $\frac{3}{8}$ inch wide is nailed to the sides; upon these the bottom trays rest. A crossbar (E), with $\frac{5}{8}$ -inch block (F) to hold the trays securely in place and prevent them from rising in the water, is made to fit in the grooves at the sides of the trough.

The capacity of the troughs may be doubled by the addition of a second row of boxes, one side of the first tank acting as a partition between the two rows. Each box holds eleven trays (G). Ten of these are filled with eggs, the eleventh, or top one, acting merely as a cover to prevent the eggs on the tenth tray from being carried off by the current. The trays are made of $\frac{1}{4}$ -inch mesh galvanized wire cloth, tacked upon frames 16 inches long, 7 inches wide, and $\frac{3}{4}$ inch thick. Both the trays and tanks are given three coats of asphaltum paint before being used, and one coat at the beginning of each succeeding season. Eleven of such trays, in the box described, will fill the compartment to within $\frac{5}{8}$ inch of the groove in the sides of the tank; then the crossbar with the $\frac{5}{8}$ -inch feet holds them securely in place. The tanks are set upon iron standards cemented in the floor, and are given a pitch of $\frac{1}{8}$ of an inch to the foot. The height of the tank from the floor is a matter of convenience to the operator, depending on the fall of water available.

The water enters through a 1-inch pipe at the head of the tank, flowing down through the first division, up through the second, and so on to the lower end. Where water is scarce, two troughs may be made to

utilize the same supply by placing one after another, the upper end of the lower trough being from 8 to 12 inches lower than the overflow of the upper trough; this gives a good aeration and will be found to answer

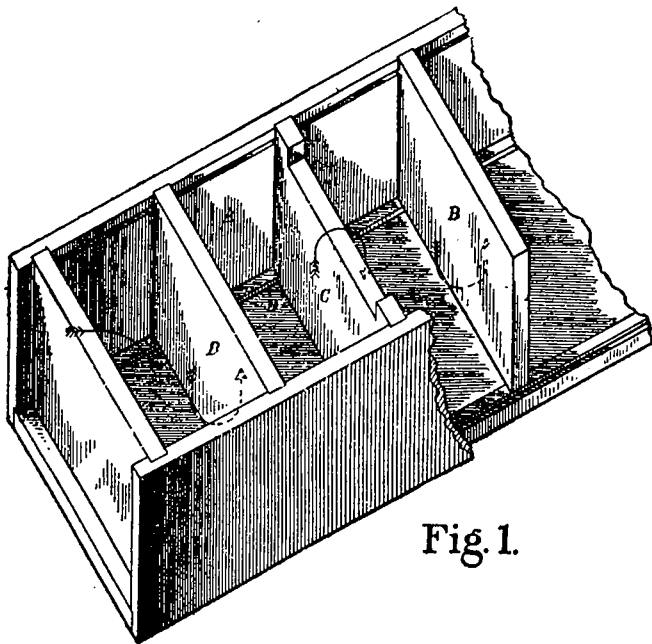

Fig. 1.

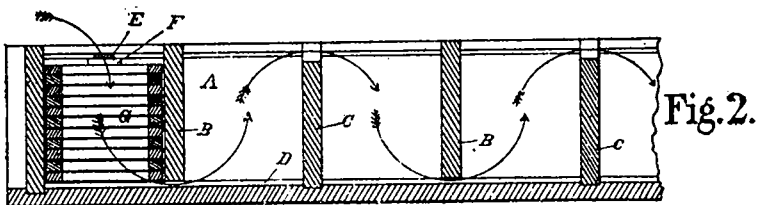

Fig. 2.

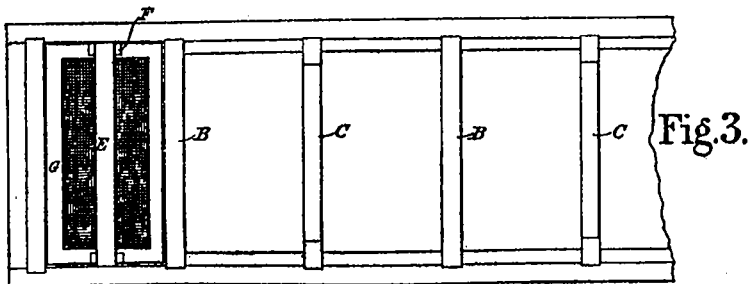

Fig. 3.

Clark-Williamson Trough.

nearly as well as though fresh water was conducted to the tank. Should the supply be taken from a creek, lake, or other reservoir exposed to changes of weather and drainage from the surrounding land,

or if it abounds with aquatic insects, it is quite essential to have some kind of filtration, otherwise the eggs may be injured by animalculæ or coated with sediment, the trays clogged with refuse, the circulation stopped, and in the end a majority of the eggs lost. Many filters have been devised, all of which are good, but a simple and effective contrivance is made by tacking medium-weight flannel to wooden tray frames and placing them at the head of the tank directly beneath the head of water, the number used at one point being governed by the amount of sediment or other foreign matter present.

At Northville, as a convenience in caring for eggs, a shallow "picking-trough" is used, 40 feet long, 10 inches wide, and $2\frac{1}{2}$ inches deep, with a $\frac{1}{2}$ -inch strip, $\frac{7}{8}$ of an inch wide, nailed along each side of the bottom, upon which the trays rest, to give a good circulation while the eggs are sorted over. The trough has a fall of not more than $\frac{1}{2}$ inch throughout its entire length, and it is fed by a flow of about 2 gallons of water per minute. A dam at its lower end raises the water $1\frac{1}{4}$ inches, not entirely covering the trays. This is a point that must not be overlooked, for if the water flows over the tops of the trays many of the eggs and fry will be apt to escape through the waste-pipe.

CARE OF THE EGGS AND FRY.

Upon their arrival at the hatchery the eggs are taken from the shipping-cases and turned into tubs, whence they are removed to the hatching-troughs. In removing eggs from the flannel shipping-trays to the tub the same method is followed as in washing eggs that have been held in cases for several days. The transfer should take place in a temperature not higher than 45° or 50° F., and if the eggs are held in the tubs for any length of time they are given a change of water every 30 minutes.

Great care is necessary in transferring eggs to the hatching-trough in pails. To guard against any shock, the pail is partially filled with water, and the eggs are carefully taken in the dipper, which is lowered into the pail in such a way that the eggs will glide into the water and not fall upon it. The pail when filled is placed upon the trough as near as possible to the box for which the eggs are intended, and by means of a perforated dipper with a capacity of 20 ounces, or 4,000 eggs, they are transferred to the hatching-boxes. A tray is placed in the water and one dipperful poured upon it, whereupon a second tray, placed on top of the first, is served in like manner, and this is repeated until ten trays are filled. The eleventh, or cover tray, is left empty, and the whole apparatus is held in place with a crossbar or binder. In two double troughs, containing 64 boxes and occupying a floor space of 106 square feet, 2,560,000 eggs may be safely carried with 22 gallons per minute of good spring or lake water, well aerated.

To estimate the number of eggs laid down, a fractional portion of a quart is counted several times until a satisfactory average is arrived at; this has given 200 to the fluid ounce, or 6,400 to the quart.

For the first few weeks after the eggs have reached the hatchery close attention must be given to prevent the growth and spread of fungus throughout the tank. The eggs must be carefully hand-picked, and the trays and boxes kept thoroughly cleansed from slime and other impurities. If a heavy rain should wash dirt, refuse, etc., into the supply reservoir and thence to the hatchery, the eggs must be cleaned to prevent their smothering. No filter, practical for use in a hatchery, has been invented that will entirely remove injurious substances.

To remove the egg-trays from the boxes for sorting, the binder is first slipped out from the grooves and the trays taken out separately, each rising to the surface as the one above it is removed. All the trays are taken out of one box and placed one after another along the picking-trough. The dead eggs and "ringers"—the latter not appearing until in the later stages of incubation—are then picked out with small metal tweezers. The eggs will turn white when dead, and if allowed to remain upon the trays a fungus will soon appear upon their surface and spread its growth until all the eggs within a short radius are affected; these in their turn will be smothered and become fungussed in the same manner.

When it is necessary to change the position of the eggs in order to bring those at the bottom to the surface a soft feather is used, and if manipulated carefully it will have no injurious effect. After the eggs have been carefully sorted the trays are again placed in the hatching-box. The eggs are looked over at least every three days during the first five or six weeks; at the end of that time, in a water temperature of from 40° to 45° F., the eye-spots will show up plainly, and from this stage to the breaking of the shell less labor need be expended in this direction, for the eggs are not so susceptible to fungus, etc., as in the early stages. At this period unimpregnated and imperfectly developed eggs are easily distinguished and taken out at one picking, leaving practically only those that will ultimately hatch as perfect fry.

For washing the eggs when coated with sediment a large galvanized-iron pan, about 2½ feet long, 1¾ feet wide, and 4 inches deep, is used; this is nearly filled with water and a tray floated on its surface. The eggs are gently moved about with a feather, and by submerging and quickly raising the tray the eggs will be left as clean as when first taken. It is necessary to be very careful to give no sudden jar or shock to the eggs, for up to the time the eye-spots begin to appear they are very delicate and must be handled accordingly. It is better to allow a small amount of dirt to remain on the eggs than to undertake washing them, which should only be done when the coating of sediment becomes dangerously heavy. The boxes may be washed when the trays are in the picking-trough, but to wash the trays is difficult, yet very necessary in case they become covered with slime.

The eggs may be transferred to a clean tray without serious harm by placing the clean tray face downward upon the dirty one, and by a quick movement reversing their positions, submerging both trays in a

pan of water. This will deaden the fall of the eggs from one tray to the other and free what few adhere to the first tray.

In a water temperature of from 40° to 45° F., hatching will begin in from 75 to 90 days. The dark hue of the egg as a whole, the distinct outline of the fish, and its convulsive movements show the approach of the hatching period. If the weather is clear and cold these indications may continue for some time, but with the advent of a single warm day more than 50 per cent of the fry are apt to break their shells.

As the total number of eggs received at the hatchery has decreased, in order to determine the number of fry that will be hatched they are now measured again by first emptying the eggs in the large pan described above, and then placing 4,000 each upon trays, in this case made of wire cloth with a $\frac{1}{4}$ -inch mesh. Should the temperature remain uniform the hatching will cover a number of days, but a sudden rise or fall in the temperature will have a marked effect in either advancing or retarding the further development of the eggs.

The dead shells from the hatching fish must be removed or they will clog the trays and stop the circulation of water. To provide against this, one box of trays is emptied into a pan of water and the eggs stirred with a feather; the shells rise to the top and can be easily poured off, and by repeating this operation several times the hatching fish are entirely freed from this refuse. In returning the fish and eggs to the trays they should be divided as equally as possible among the ten trays. The necessity for this depends on the rapidity of hatching and perhaps a single box need be served in this manner only three or four times during the hatching period.

The care of the fry from this time to their distribution, if distributed before the absorption of the food-sac, is somewhat similar to the treatment described for eggs. Monstrosities, "blue-sacs," and dead fry are picked out as soon as they are discovered. The yolk-sac attached to the fry will be gradually absorbed and the fry so increase in size that 4,000 overcrowd one tray, and when the sac is about half gone, which is in about three or four weeks after the fish are hatched, it is necessary to reduce the number upon each tray to 2,000.

DISTRIBUTION OF THE FRY.

Lake trout should either be planted while the food-sac is still visible, or not until they possess the vitality of the yearling. Trout planted when the food-sac is within one or two weeks of complete absorption have sufficient nourishment to sustain life until they are acclimated to their surroundings, as well as the natural impulse from the beginning to take the minute particles of food which they find. As from 2,000,000 to 4,000,000 lake trout are hatched at Northville annually, it is impossible, with the present facilities, to hold them all in rearing-troughs and ponds until they become yearlings, and the fry are usually distributed direct from the hatching-boxes.

In shipping them to their destination, 10-gallon round-shouldered cans are filled to within a foot of the top with the water used in hatching. One trayful, or 2,000 fry, is put in each can, and as soon as it is filled, enough ice is added to bring the temperature down to 38° or 40° F. If the fry are to be planted in the Great Lakes, the cans are transferred from the car, upon its arrival at its destination, to a fishing-tug and conveyed to the reefs or natural spawning-grounds of the lake trout; here the cans are lowered into the water and the fry allowed to escape and in a few moments they disappear from the surface and sink to the bottom.

PACKING EYED EGGS FOR SHIPMENT.

When the eye-spots are plainly visible, the eggs can be packed and successfully shipped to any part of the world, if kept at a uniform temperature. The trays used for this purpose are made like those used in shipping green eggs from the field station to the hatchery. For 100,000 eggs 16 trays, 18 inches by 18 inches, are required; for 50,000, 8 trays, 16 by 16; and for 5,000 eggs, 5 trays, 8 by 8. After they are packed, the trays are placed one upon the other and crated together by nailing a cleat on each side from the foundation to the top board. The packing-case is made large enough to admit of an air-space of 4 inches around the top, bottom, and four sides of the crate, when it is placed in position. Rope handles are inserted at the sides.

The temperature of the packing-room should not be higher than 40° nor lower than 26°. A temperature of from 28° to 30° is preferable. The cotton-flannel trays are first soaked in water, drained, and then placed upon a table to receive the eggs. Wooden frames of $\frac{3}{4}$ -inch square strips, made so as to fit inside the frames of the packing-trays, are then inserted. A box of eggs, previously picked and cleaned, is taken out, drained, and carried to the packing-room. The eggs are carefully brushed from the wire trays upon the flannel trays with a feather and spread evenly over the surface. To divide the eggs among the flannel trays is not difficult, as there are 40,000 in the hatching-box, or 4,000 to the tray. The inner wooden frame is now removed, leaving a $\frac{3}{4}$ -inch margin on all sides between the eggs and the tray frame, and a piece of damp mosquito netting is laid over the eggs, extending $1\frac{1}{2}$ inches beyond the sides of the frame. This netting is pressed down at the inside corners of the tray and all along next to the frame, in order to hold the eggs in position and avoid their coming in contact with the wooden frames. Over this netting is scattered sphagnum moss, $\frac{1}{2}$ to $\frac{3}{4}$ of an inch deep. This moss is gathered in the fall, and is prepared by being soaked in water and wrung out with a clothes-wringer. It must be free from all sticks and decayed matter and thoroughly wrung out, picked apart, and made fluffy, for if used upon the eggs in a compact mass, the supply of oxygen would not be sufficient for their maintenance while en route. It should be moist, but not so wet as to drip on the eggs.

When packed the egg-trays are placed upon a foundation-board, made the same size as the trays and covered with moss. At the top another board of the same dimensions is laid. Cleats are nailed on all four sides and fastened to the top and foundation boards, making a firm crate, which can be handled without danger to its contents.

If the temperature of the packing-room is not below freezing, the trays are placed out of doors before they are crated, to allow the moss upon the eggs to become slightly frosted. Eggs at this period may be subjected to a very low temperature without injury—in fact, may be enveloped in a thin coating of ice, and if shipments are made when the weather is too warm for frosting the results are not so good.

A packing-case, provided with rope handles, is prepared large enough to admit of an air-space of 4 inches around the top, bottom, and four sides of the trays. The bottom is filled 4 inches deep with fine shavings, the crate of eggs is placed upon them, and more shavings packed all around between the trays and the case. The packing is carefully done, a few shavings being thrown in and pounded down before more are added, in order that the trays may be held securely in the center of the case. Shavings are filled in on top, the cover screwed on, and the box is ready for shipment.

In transit the eggs must be kept in a cool place, though not allowed to freeze; and if this precaution is taken, and they are not unnecessarily jolted, they will be found in good condition when unpacked. Hundreds of thousands of eggs have been thus shipped from Northville during the past few years, the eggs arriving in fine condition and with practically no loss.

For foreign shipments a double box is used. The inside one is made $2\frac{1}{2}$ inches larger on all sides than the crate of trays, and the outside one large enough to make a 5-inch space on all sides when the smaller box is placed within it. The trays of eggs are prepared as in ordinary shipments, and, when crated, are placed in the smaller box upon a frame which is constructed from a $\frac{1}{8}$ -inch strip, $2\frac{1}{2}$ inches wide, tacked at right angles to the inside and bottom of this box. In the space thus formed between the crate and the box is packed finely chopped ice, water from the melting ice being drained off through a half dozen small openings in the bottom of the box. This box is now packed according to the same plan as that followed with shipments for a short distance. Where there is an opportunity it is advisable to have the case unpacked while en route and fresh ice added. Eggs have been shipped in this manner to England, Mexico, New Zealand, Japan, and South America, and have reached their destinations with little loss.

FEEDING AND REARING LAKE TROUT.

Lake trout fry held for rearing are kept in troughs until they are large enough to be transferred to ponds. These troughs at Northville are 12 feet long and 2 feet 7 inches wide, with a 1-inch partition running through the middle its entire length, thus forming two troughs, each

1 foot 2 inches wide. At intervals of 18 inches, cleats $1\frac{3}{4}$ inches high are mortised across the bottom, and in the sides of the trough, at the ends of the cleats, grooves are made to admit the placing of a fine-meshed vertical screen, which can fit tightly to the partition at the bottom. Everything is coated with asphaltum paint. The trough has a fall of one-fifth of an inch to the foot, the overflow being at the end through a tin spout. Another trough may be set at the lower end of the first, provided, as with hatching-troughs, a sufficient fall is given for aeration.

A week or ten days before the disappearance of the yolk-sac, which will be absorbed in five or six weeks, with water at a temperature of 40° to 45° , the fry intended for rearing should be transferred to the troughs. In a single trough of the size described, 15 gallons of spring water per minute, with a temperature ranging from 45° to 50° F., will support 8,000 fry during the first few weeks they are held. Up to this time it is not necessary to insert the vertical screens except at the head and outlet, but as the fry increase in size they become restless, snapping at each other and crowding together in a mass at the head of the trough, and then it is necessary to thin them out and separate them by subdividing the troughs, holding an equal number of the fry in each of the compartments. The action of the fish determines when this should be done. The use of warm water hastens the development of the fry, the same as it does with the eggs.

For the first four weeks the fry are fed four times per day on finely chopped beef liver, ladled through a close screen to remove all lumps. The liver is diluted with water and the mixture fed to the fry with a feather. For some days they do not appear to take their food, but the routine is continued, and as soon as the sac is entirely consumed they commence feeding. No rule can be laid down prescribing a definite amount of food, but the fry are fed till their appetites are appeased and every fish has obtained a morsel. Some days they display more hunger than usual, a warm day especially increasing their appetites. After they begin to feed well the liver may be given to them but three times a day, more being thrown in at a time.

The troughs must be cleaned out daily by turning on an additional supply of water—not so much that the fish will be carried against the screen—and the foul matter stirred up from the bottom with a feather and worked through the wires with a small sponge. Twice a week the sides and bottom are sponged off.

Three months after being transferred to the feeding-troughs, trout will take food well and be from 1 to 2 inches long. They are then ready to go outside to the rearing-ponds. These ponds are about 32 feet long by 5 feet wide, with from 10 to 20 inches of water, and have a minimum water supply of 20 gallons per minute. The bottom is graveled and the sides constructed of planks or cobblestones, and on the sides where the sun strikes the warmest during the day a board shades the trout

from the direct rays. A pond of this description will accommodate 10,000 lake trout three or four months old. As they increase in size this number may be diminished, a great deal depending upon the quality and temperature of the water.

The temperature of the water should never be higher than 65°; preferably from 48° to 58°.

As when kept in rearing-troughs, the fish are now fed the amount they seem to desire, being neither overfed nor starved. The liver, not so finely chopped as before, is thrown in with a spoon. At the first feeding the fish may be somewhat wild and scatter over the pond, but after one or two days they will collect at one point and take the food greedily. After four weeks' time they are fed only twice per day, and as they increase in size, coarser liver is given to them. Food is thrown in slowly, and no more given at one time than the fish can eat, for waste matter soon becomes foul, and unless drawn off will speedily cause sickness.

In from 10 to 12 months after hatching, lake trout artificially reared measure from 4 to 8 inches in length and are ready for planting. This is done in the same manner as with fry, 100 fish being placed in each can for transportation.

DISEASES.

The diseases to which lake trout are susceptible are those common to all other trout. They are caused by impure water, poor food, injuries received, and the attempted cannibalism of their neighbors. The first three of these causes can be guarded against, but the last is much more difficult to prevent. At the first sign of cannibalism the fish must be thinned out, and, if feeding well, transferred to the rearing-pond, where they will have greater range for development. In fact, for any of the diseases this will prove of more benefit than anything else.

It is beneficial to treat the fry with salt twice a week by shutting off the water and sprinkling salt in the trough until a weak brine is formed. The fish must be watched closely, and as soon as they show any signs of "turning up" a full head of water must be turned on until all the brine is washed off, after which the supply may be reduced to the regular amount. A small quantity of swamp earth should be scattered in the tanks about once in two weeks, merely enough to discolor the water for a few moments, and allowed to wash off gradually with the current of the water.

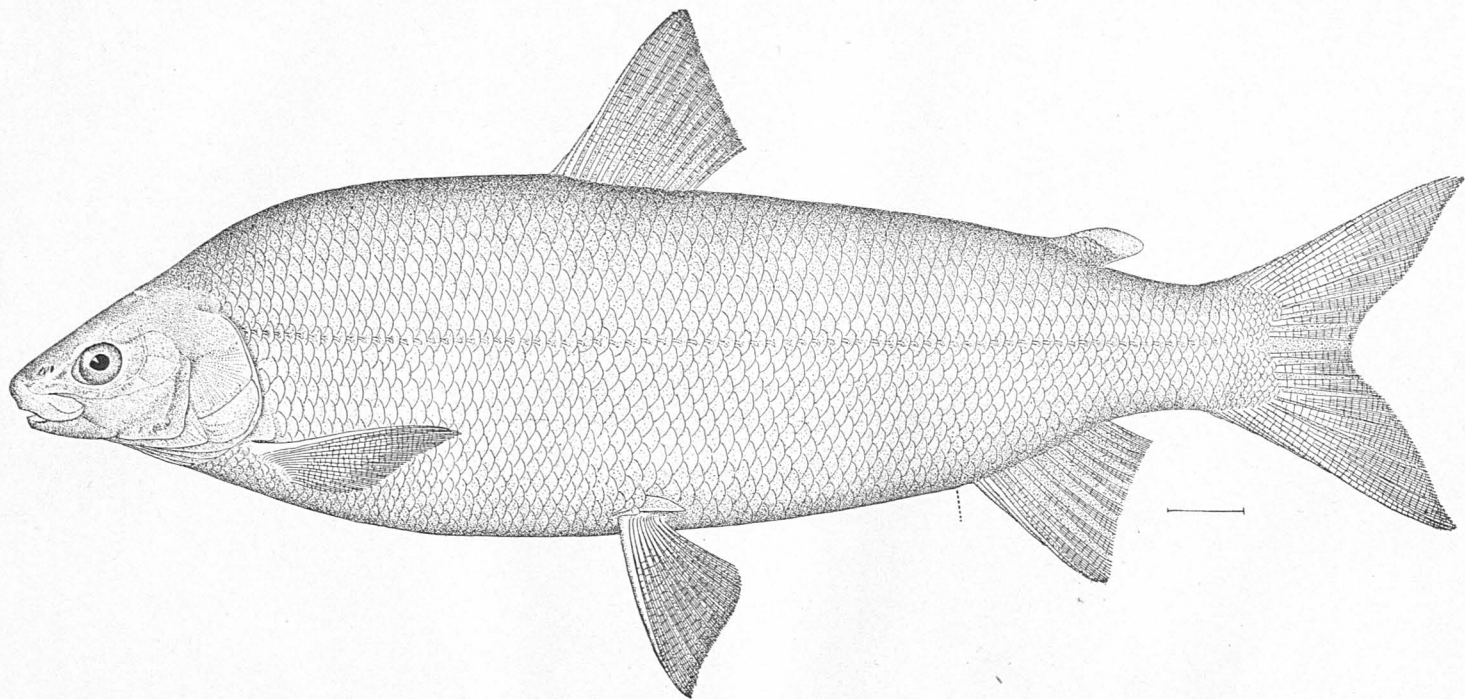

COREGONUS CLUPEIFORMIS. *Common Whitefish.*

THE WHITEFISH.

DESCRIPTION, COMMON NAMES, ETC.

The common whitefish (*Coregonus clupeiformis*) is eminently a lake fish. It exists throughout the Great Lakes region, and is especially abundant in lakes Erie, Huron, Michigan, and Superior. The eastern limit of its range is Lake Champlain, and it is found in Lake Winnipeg, and possibly farther west. It is landlocked in Otsego Lake, New York. Efforts to introduce it into new waters in the States of the Pacific Coast and Rocky Mountain region have not as yet been successful.

Its body is rather long and compressed, and the back, especially in adults, is arched in front; the greatest depth is about one-fourth the body length. The head is small and short, contained about 5 times in the length of the body; the snout is blunt; the mouth is small and nearly horizontal with the lower jaw included; the maxillary is short and broad, reaching to a point under the pupil; the mandible extends to a point under the posterior edge of eye. The eye is small, its diameter being about one-fifth the length of the head. The rays in both the dorsal and anal fins number 11. The number of rows of scales along the side of the body varies from about 82 to 92, with about 11 above the lateral line and 8 below. The gillrakers number about 28, of which 10 are on the upper arm of the gill-arch; the longest are contained about twice in the length of eye. The general color of this fish is a satiny white, with a faint olive-green shade on the back. The fins are uniformly white, except the caudal, which normally has a dark edge.

This fish has a number of common names in different parts of its range. It is the whitefish par excellence of the United States and Canada. As found in Otsego Lake, New York, it is inappropriately called "Otsego bass." In allusion to its humped back it is called "highback whitefish," "bowback whitefish," "buffalo-back whitefish," and other similar names, in Lake Superior.

While more is known of the habits of this species than of any other member of the group, many phases in its life are still obscure, as it remains in deep water most of the time. Besides the regular annual movements of the schools to the spawning-grounds, there are other well-marked migrations in some lakes. Whether these depend on food, temperature, enemies, or other causes, is not known. Owing to its small, weak mouth, it is seldom taken with a baited hook. It subsists on minute animal food, chiefly crustaceans, mollusks, and insect larvæ. The food of the fry and young fish is almost wholly small crustaceans.

COMMERCIAL AND FOOD VALUE, ETC.

The whitefishes are by far the most important group of fresh-water fishes of North America, probably of the world. The common whitefish is the best of the tribe, but some of the others nearly equal it in merit, and all are more or less esteemed as food. Among the fishes of the Great Lakes the common whitefish ranks next in value to the lake herring, lake trout, and wall-eyed pike. In 1893 the catch in the United States was over 8,000,000 pounds, having a value of over \$330,000. If to this is added the yield of other species (namely, about 36,000,000 pounds of lake herring, valued at \$536,000, and upward of 3,000,000 pounds of other whitefish, valued at \$85,000), the aggregate is over 47,000,000 pounds, having a value of \$951,000. The market value of the whitefishes taken in 1893 in the British Provinces was reported as \$1,535,000, a sum representing about 30,000,000 pounds.

The common whitefish reaches a larger size than any other species of whitefish in the United States. Examples weighing over 20 pounds have been taken, but the average weight is under 4 pounds.

Whitefish fishing is done chiefly with gill nets set at or near the bottom in comparatively deep water, although considerable quantities of whitefish are also taken in pound nets, trap nets, and seines.

SPAWNING.

The spawning season of the whitefish begins the latter part of October and continues into December. At that season there is a general movement of the fish to shoal parts of the lakes, similar to the migration of anadromous fishes from the ocean to the rivers; some of the the foreign whitefishes are typical anadromous species. After spawning, the fish return at once to the deeper water.

The spawning habits of whitefish confined in pens have been observed. The fish rise to the surface, occasionally in pairs, sometimes, but rarely, in trios of one female and two males, the female emitting a quantity of spawn at each rise. The males, always the smaller fish, persistently follow the female and discharge milt at the same time the eggs are emitted.

Whitefish reach maturity in the third or fourth year. A full-grown specimen deposits from 10,000 to 75,000 eggs, depending on the fish's size. A rule for determining the approximate spawning capacity is to allow about 10,000 eggs for each pound of the fish's weight. The eggs when fully swollen are an eighth of an inch in diameter, and 36,000 make a fluid quart. They swell somewhat after impregnation.

DESTRUCTION OF WHITEFISH SPAWN IN NATURE.

In nature the eggs of the whitefish are subjected to the attacks of many enemies for nearly five months. The mud-puppy (*Necturus maculatus*), commonly known as "lizard" or "water-dog" by the people along the lakes, is especially destructive. During the month of Janu-

ary, 1897, many of these animals were pumped up with the water supply of Put-in Bay station. The stomachs of a considerable number of them contained whitefish and cisco eggs, the contents of one stomach being 288 whitefish and 4 cisco eggs.

Another voracious destroyer of the whitefish is the common yellow perch (*Perca flavescens*). The deck of a boat has been seen covered with the eggs of the whitefish and cisco pressed out of the stomachs of perch taken from gill nets the last of November on the reefs, where they had gone to feed on the eggs.

The various smaller *Cyprinidæ* and some other fishes, crawfish, and wild fowl make the eggs of fishes a considerable portion of their diet, those which require the longest period in hatching, of course, suffering most.

ARTIFICIAL PROPAGATION.

The artificial propagation of whitefish has long since passed the experimental stage and has attained a high degree of perfection. The work can be carried on with great facility, and its value is especially apparent when it is considered that under natural conditions only a very small percentage of the eggs hatch, while through artificial propagation from 75 to 95 per cent are productive. Practically all the eggs taken for hatching purposes are obtained from fish caught by the commercial fishermen, which would otherwise be lost.

The methods of culture hereafter referred to are those adopted at the Put-in Bay (Ohio) station, but these do not differ in any essential particular from those in general use.

In the fiscal year 1895-96 the United States Fish Commission hatched and planted 189,690,000 whitefish fry, and in the subsequent year 95,049,000 fry were hatched and liberated in suitable waters.

HOW THE EGGS ARE TAKEN AND TREATED.

The taking, impregnating, and handling of the whitefish eggs are simple processes, but require great care at every stage. Eggs are often injured by undue haste in stripping, and many are lost by allowing them to fall too great a distance into the spawning-pan. Eggs are very delicate when first taken and before the absorption of water has made the investing membrane tense, and if roughly treated will be seen to be ruptured as viewed under the microscope. With care about four-fifths of the eggs will hatch. Improper attention to the impregnating process may also result in serious loss of eggs. While scarcity of milt may lead to the nonfertilization of the eggs, the manner in which the milt is brought in contact with eggs is a more common cause of failure.

The eggs supplied by each spawn-taker should be examined daily, and if it is found that a considerable number have ruptured yolks it may be taken for granted that the spawn-taker has handled the fish and eggs roughly, and if many are unimpregnated it is evident that he did not use sufficient milt or that it was not properly applied to the eggs.

At Put-in Bay eggs are obtained from fish captured in pound nets and gill nets, often at considerable distances from the station. The spawn-taker, who is employed to take the eggs from the fish as they are lifted from the nets into the boat, has with him two or three 6-quart pans, coated with asphaltum varnish to prevent rusting, in which he takes the spawn; a wooden keg or tin can holding from 10 to 15 gallons; a 10-quart wooden pail, and a tin dipper. He is clothed in waterproof garments, and his left hand is covered with a woolen mitten for convenience in handling the fish.

After several ripe females and some ripe males are collected, a female is taken, and the body slime, which will interfere with impregnation if it falls into the pan, is carefully removed. The spawn-taker then grasps the fish firmly in his left hand, just forward of the tail, with the back of the hand downward, the fingers outward, the thumb above and pointing outward, the head of the fish being toward the spawn-taker's body. The right hand is placed under the fish just back of the pectoral fins, with the wrist pressing the head of the fish firmly against the body, the thumb outward, fingers inward, thus grasping the upper abdomen firmly. The fish is now at an angle of nearly 45° , the body forming a modified crescent, with the vent within 4 or 5 inches of the bottom of the pan. This position of the fish's body brings pressure on the abdomen, facilitates the flow of the eggs through gravity and the opening of the vent, and prevents injury to them from falling too far. (See plate 34.)

Gentle pressure being now applied, the eggs flow in a steady, liquid stream about a quarter of an inch in diameter, and a considerable portion of them will be procured before the hand need be moved. As soon as the stream slackens the hand is slowly moved toward the vent, but only fast enough to keep the eggs coming in a continual stream. When it finally stops the hand is replaced in its former position and the process repeated until all the good eggs are procured. If, as is frequently the case, when nearly all the ripe eggs are emitted a considerable number of white ones appear, the work should stop.

The dry process of impregnation is now universally considered to be the better, and the pan in which the eggs are taken is only dampened by dipping it into water before the stripping begins. After two or three females have been manipulated the milt from one or two males is added to the mass of eggs. This is done by grasping the fish between the thumb and fingers 2 or 3 inches forward of the vent and moving them toward the opening. The milt comes in a stream, an average fish producing about a teaspoonful. If ripe males are scarce the fish is laid aside, as he may be used again in a few minutes and considerable additional milt procured.

When the pan is one-half or two-thirds full of spawn and milt, the spawn-taker gently stirs the eggs to incorporate them thoroughly with the milt, using for this purpose the tail of a fish, from which the slime has been carefully removed. The pan is then partly filled with water and the mass again very gently stirred. After standing two or

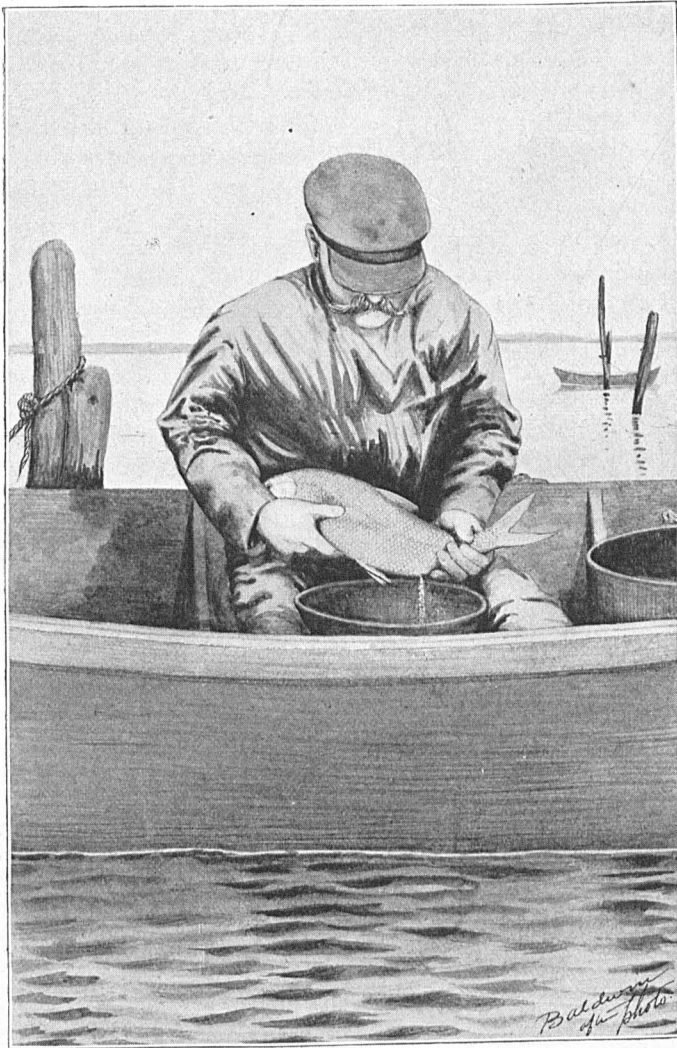

STRIPPING A WHITEFISH.

three minutes, the water is poured off and fresh water added, and this is repeated until the water comes away clear, when the eggs are poured into the keg or can previously filled with water, and the work of taking spawn is continued. Before adding another lot those previously put into the keg are gently stirred. It is necessary to change the water on the eggs at least once an hour, and oftener if the weather is warm, and the eggs should be gently stirred to the bottom of the keg every 30 minutes until they are placed in running water in the hatchery.

When the spawn-taker has finished he turns over the eggs to a man in charge of the field work, who cares for them until the collecting steamer comes, when they are taken aboard and transported to the station, some 2 to 5 hours having elapsed since they were taken. At the station the eggs are kept in the kegs in which they were placed by the spawn-taker and a stream of water of about 2 gallons per minute to each keg is kept running on them until the next morning, and they are stirred to the very bottom once an hour in the meantime. In this way the eggs are given time to harden with less injury than if they were immediately placed in the jars.

Formerly in shipping eggs long distances they were kept in running water in kegs, under the care of a watchman, but it has been found much better to ship them in cases on trays. After having been in water 8 or 10 hours, whitefish ova may be safely placed two or three layers deep on trays and shipped indefinite distances. If the weather is warm (55° or 60° F.) the cases must be surrounded with ice, or sawdust and ice.

In placing the eggs on the trays a perforated dipper is used and a little practice soon shows about how many to dip out for each tray, and if just enough water is left with the eggs a slight tilting of the tray will distribute them evenly over its surface. Then by setting the tray with one corner on the floor and the diagonally opposite corner raised 3 or 4 inches, the surplus water will soon drain off. This may be facilitated by slipping a thin wooden wedge between the cloth and wood at the lower corner of the tray.

In shipping a distance of 40 or 50 miles, the trays may be placed in the cases with no other protection from change of temperature than the wood of which they are constructed—an inch thickness of tray and an inch of case with an inch of air-space between—which is found to be safe in a cool car or room in a boat, but for longer distances about 20 trays are fastened together with thin strips of wood tacked to either side and placed in a large case with from 4 to 6 inches of pine sawdust well packed on every side.

After the eggs are placed on trays and drained, they are covered with a thickness of mosquito netting, well washed and left damp, and over this is packed enough damp moss to fill the tray even with the surface. If eggs are to go by express, unaccompanied by a messenger, directions are fastened to the case stating that they must be kept cool but not permitted to freeze. Whitefish eggs have been safely shipped in this way from Northville, Michigan, to Australia. If the eggs are

to be shipped a short distance—25 to 50 miles—it is not necessary to cover them with moss.

The trays used at the station are 16 inches square, outside, and are made of white pine $\frac{3}{4}$ by 1 inch, mortised together at the corners with the widest side of the strip horizontal. On the bottom of these frames heavy canton flannel is tacked, so that the nap will come next to the eggs when in use. The cloth should be stretched very taut, otherwise it will sag on being wet and dried. The tacks are put $2\frac{1}{2}$ to 3 inches apart, so that in a year or so it can be retacked between the ones first driven to take up the slack. The trays are made square, as they then go into the cases either way and time is saved in packing; square cases are also more convenient in storing and in handling generally. Such a tray will hold 50,000 eggs.

If the eggs have to be retained for several days in the field, they are sometimes kept in floating-boxes adapted for this purpose. (See description of this box on p. 107.) But unless the conditions are very favorable it is far better to place the eggs on trays, sprinkling them lightly once in two or three days.

When taken from the kegs and trays at the hatchery the eggs are passed through a screen (with meshes sufficiently large to permit the passage of a single egg) in order to remove scales and other foreign substances that may be present. The screen is floated in a washtub partly filled with water, the wire netting being well submerged.

For handling eggs and fry wooden kegs are by some preferred to tin cans, as they do not subject the eggs and fry to sudden changes of temperature, their contents are easily examined, and the water is more readily poured off without danger of losing eggs. The kegs are much lighter, only cost a third as much as cans, and last longer. For shipping in wagons or by rail, however, tin cans with covers are indispensable. Kegs should be made of white pine, painted outside but not within, and hold about 15 gallons each, and should be provided with iron drop handles.

PENNING WILD FISH.

The uncertainty of the seasons and the liability of failure to obtain spawning fish owing to severe storms which occur in November, make it desirable, wherever practicable, to capture fish in favorable weather and place them in pens until ripe. After the fish are driven off their spawning-grounds by severe storms, they do not return in large numbers during the spawning season, and the only way to insure a satisfactory supply of eggs is by penning the fish.

Nets have been tried for penning, but they do not afford sufficient facilities for sorting the fish of various degrees of ripeness and the fish have to be handled too much, thus encouraging fungus growths on them and causing many to abort their eggs. Penning is best done in crates made of boards with openings sufficiently large to admit the free interchange of water. The pens are generally made about 16 feet long, 3 or

4 feet wide, and 4 to 8 or more feet deep. They should be placed end to end in two rows, some 3 or 4 feet apart with a plank walk between, for convenience in caring for them. The fish must be handled as little and as gently as possible, otherwise the eggs will form into a hard mass and never ripen. One cause of injury is the scoop net with which they must be handled; the knots and the twine are so hard that they injure the delicate scales of the whitefish, which struggles violently when taken from the water. A net made by punching suitable-sized holes in a sheet of thin, soft, flexible rubber would be yielding and perhaps cause the least injury.

HATCHING METHODS AND EQUIPMENT.

At Put-in Bay the water for hatching is obtained from Lake Erie through a pipe that extends 75 to 100 feet into the lake. Pumps elevate the water to the loft of the hatchery, where it is received into supply-tanks, whence it is distributed by the usual methods of piping. The circular supply-tanks, two in number, are about 11 feet in mean diameter, 8 feet high, and have a capacity of 5,000 gallons each. These tanks are necessary to give an equal pressure in the pipes and to provide a supply of water in the event of cessation of pumping. A gauge in the boiler room shows the height of water in the tanks.

Whitefish eggs are hatched in the McDonald jar and the Chase jar; the former is in more general use in the United States Fish Commission, although both give satisfactory results. The eggs are put into the hatching-jars by means of a dipper having a perforated bottom. The proper number to a jar is $3\frac{3}{4}$ quarts, as determined by a gauge; these will swell to $4\frac{1}{4}$ quarts, which is about the proper quantity for the jars used.

The form of the embryo whitefish can be seen in the egg by the use of a magnifying glass in from 10 to 15 days and the eye-specks and color stars in from 15 to 20 days, the time depending much on the temperature of the water. The fry being hatched, the food-sac is absorbed in from 5 to 15 days, varying somewhat with the period of incubation. If hatching is long retarded by low temperatures, the sac will be nearly all absorbed when the fry hatches.

The microscope is a great aid in whitefish culture, enabling the operator to determine the exact percentage of dead eggs and to a great extent the cause of their loss, thus allowing him to remedy some if not all the evils. For examining eggs in their early stages the microscope is placed horizontally, the eggs being held in a cell filled with water. This may be easily made by fastening two ordinary glass slides to a strip of wood an eighth of an inch thick, with a portion cut away to form a receptacle for the eggs. The wood is thoroughly saturated with asphaltum varnish, and after drying the sides should receive a thin coat, the slides being laid on and placed under pressure to dry. When dry an additional coat to the outer joints of contact will guard against possible leaks.

If the egg be examined 6 or 8 hours after it is fertilized, the germinal disk will be found to have contracted to a saucer-shaped cap extending over about a fifth of the surface of the yolk. It is smooth and even, gradually thinning to a sharp outer rim, with a thickness in the center of the cap of about a fifth of its diameter. At this stage—segmentation not having commenced—the impregnated eggs can not be told from the unimpregnated ones. At 18 hours segmentation will be well advanced and the disk will have contracted into six or eight rounded nodules of uneven size, with well-defined valleys between, there being no longer a sharp rim to the disk. At 24 hours—the best time to determine the percentage of live eggs—the disk presents a somewhat similar appearance, except that it will be divided into 25 or more segments, easily seen under the glass; the disk of the unimpregnated egg of the same age forms an almost exact hemisphere, is perfectly smooth in appearance, and is therefore easily distinguished from the live egg. Segmentation now goes on rapidly, and at 72 hours the cells look under a 1-inch objective—a suitable power to use in this work—about the size of a mustard seed, the disk having in the meantime assumed an hemispherical shape.

During the entire period of incubation, but more especially during the early stages of growth, the eggs should be worked as gently as possible; that is, only sufficient water should be used to keep them in slow motion and to prevent “banking.” At the commencement they require about 6 quarts of water per minute to the jar, but later they will run with a quart less per minute. The eggs require constant watching for the first week or more, and although not considered an adhesive egg, agglutination takes place occasionally when the water becomes roily. Unless the “banks” so formed are separated by gently stirring them with a long feather (the long wing feathers of a turkey are suitable), the eggs forming the pack soon die and form a mass in the jar.

In a few days, varying with the temperature of the water, the unimpregnated and other dead eggs begin to “fungus”—that is, a growth makes its appearance on them and they rise to the top of the egg mass—when they must be removed by the use of a siphon, and if live eggs are among those drawn off, they must be set up in what are called “hospital jars,” where the live and dead ones are more readily separated.

The dead eggs are drawn off every day, otherwise they are liable to become loaded with silt from the water and sink, mixing with the live eggs and making it difficult to separate them.

For the removal of dead eggs from the jars a long-distance siphon is used at Put-in Bay station, which saves much labor. It is constructed thus: To the short end of the ordinary siphon, which consists of a thin quarter-inch brass tube about a foot long bent into the form of a goose neck, is attached a piece of common rubber tubing 3 or 4 feet long with a $\frac{3}{8}$ -inch interior diameter. This is connected with a rubber tube of the same size and long enough to reach the whole row of jars or all in the

house if desired. The connection is made by a thin brass nipple with the same interior diameter as the piece of rubber tube to be joined by slipping it into the longer piece and lashing it on the outside with twine, leaving about three-quarters of an inch outside to slip into the shorter piece after the siphon is started. The other end of the long tube is connected with a like piece of brass tubing, bent to a quarter circle to prevent the rubber tubing from kinking, to and through the center of a wooden float some 12 inches in diameter and 1 or 2 inches thick. This is placed in a tub or large pail; the short siphon is started and connected as above described, and the long siphon is in working order. The water runs over the rim of the tub into the sluice, over which it is placed, and the eggs settle to the bottom. A whole hatchery can be operated without moving the tub, although it is better to raise it 5 or 6 feet from the floor for the upper rows of the jars, as the suction otherwise becomes a little too strong and liable to injure the good eggs when passing too rapidly through the tube.

For convenience and for economy of space and water, the hatching jars are arranged in tiers, constituting what is known as a "battery." The structure of a battery, with its complicated system of supply and waste troughs and with the jars and their attachments, is rather difficult to describe clearly, but may be understood by reference to plate 35, at the end of the volume.

Each battery is divided into two sections, which have four rows of jars on each side, setting on shelves 3 feet apart. The water is admitted through an iron pipe to the uppermost cross-tank; from there it runs into the uppermost supply-trough, which, like all the others, is 13 inches wide and 9 inches deep, inside measurements. The iron pipe is provided with a ball-cock, regulating automatically the supply of water. The supply-troughs are from 22 to 34 feet long, the upper ones being the shortest and the lower the longest. The first supply-trough has a row of brass cocks on either side taking the water 1 inch from the bottom. A half-inch rubber tube, 6 inches long and forming when adjusted a quarter circle, is slipped over the outer end of the cock and the upper end of the iron tube, which is inserted in the jar. The water flows from this upper supply-trough, which may be called No. 1, in section No. 1, through the cock, rubber tube, iron tube, and jar, from which it is discharged into what may be called waste-trough No. 1, which is directly below supply-trough No. 1. This discharges its water into a cross-tank, the second from the top, which carries the water across to supply-trough No. 2, which is in section No. 2. This supplies the second of the eight rows of jars, through which all the water passes, and after passing through the jars, as before described, it empties into waste-trough No. 2, in section No. 2, which carries it to cross-tank No. 3, which in turn carries it across and delivers it to supply-trough No. 3, which is in section No. 1. Thus the water goes back and forth from one section to the other, dropping a step at each passage, until it finally enters the fry-collecting tank on the floor, which is $3\frac{1}{2}$ feet wide, 9 feet long, and 2 feet deep.

The cross-tanks are in steps, like a flight of stairs, which accounts for the unequal lengths of the supply-troughs. Each has an overflow in the center, over which a small amount of water is kept running, so that the attendant can see at a glance that all of the troughs are full. Screens are interposed at such places in the cross-tanks that the fry discharged into them through the waste-troughs can not enter the opposite supply-troughs, but will float with the overflow successively into the lower cross-tanks down to the fry-collecting tanks.

The fry-collecting tanks, one for each battery, are connected with the main collecting tanks by means of 2-inch gas-pipe, fitted with valves, passing under the floor of the hatchery. The main tanks, eight in number, are 3 feet wide, 16 feet long, and 2 feet deep; in these the fry are retained until dipped out for shipment or planting.

The only marked difference between the method of operating the jars at Put-in Bay and other stations is the use of a $\frac{3}{8}$ -inch iron gas-pipe, instead of a glass tube, for supplying the jars with water, and the addition of a tin cone, 6 inches long and 1 inch in diameter at the lower end, which is soldered to the end of the iron pipe and reaches within one-eighth inch of the bottom of the jar. The tube is held in place by an iron bracket, fastened to the supply-trough and held by a thumb-screw. The cone has the effect of spreading the water and giving an easier and more thorough motion to the eggs than can be obtained with a straight tube.

At Put-in Bay the water passes through eight rows of jars, and the fact that the eggs in the lower rows of jars are just as good as those in the upper rows is proof of the practicability of the plan.

The jars require 6 quarts of water per minute to each jar on the top row, this amount again supplying the successive tiers of jars on the shelves below. If more jars are placed on the lower shelves than on the top one, a greater quantity of water must necessarily be added, equal to 6 quarts of water to each jar.

The temperature of the water must, of course, with the large quantities used, be what nature makes it, but if much above 50° F. good results can not be expected with whitefish eggs. When the work begins, early in November, the temperature of the water in Lake Erie is from 40° to 50° F., while late in the month it is generally about 35° to 38°. As soon as the lake freezes over, or ice in any considerable quantity forms, the temperature of the water as it passes through the jars remains very uniform at 32½°. When the ice goes out, which is generally about the middle of March, it rises slowly, and when the fry begin to hatch, the latter part of the month, it is generally up to about 33° or 34°.

The jars, tubes, troughs, etc., should be kept scrupulously clean. The usual coating for the inside of troughs and tanks is asphaltum varnish, but a mixture of coal tar and turpentine has proved an excellent substitute. For the first coat on new wood equal parts of each are employed; for the second and third coats one-third turpentine and

two-thirds coal tar. The tar should be as warm as the touch will bear, and the turpentine, which should be pure, should be added slowly while the mass is being vigorously stirred. The mixture dries quickly and forms a hard, durable surface, which is entirely waterproof and much more lasting than asphaltum; it is also much cheaper, an important item in a large station. While applying it the tin pail in which it is mixed is kept in another and larger one partly filled with moderately hot water. For pitching the cracks and joints the best asphaltum pitch is used, softened with paraffin to the consistency of chewing-gum—that is, just so that it will not break in cold water. This pitch holds firmly to the wood and keeps its place in warm weather. Other pitches which have been tried will run in warm weather and get hard with use, breaking when cold.

THE CARE AND PLANTING OF THE FRY.

When the fry hatch they immediately leave the jar and follow the course of the running water, some going through the succeeding jars, provided there are no screens interposed to prevent this, others through the overflows from the cross-tanks, until all reach the fry-collecting tank at the bottom, whence they are carried to the main collecting tanks. It has been urged by some that it is injurious for the fry to pass down through the lower jars with the complement of eggs, but in practice this has not been the case.

An air-jet on the inside of the screens will prevent clogging by the accumulation of eggshells and impurities suspended in the water. This may be easily arranged by providing an air-pump and connecting with it a pipe carried along the side of each tank on the inside of the screen and thence at right angles parallel to the screen and about an inch distant. This cross-pipe should be perforated on one side with holes $\frac{1}{2}$ inch in diameter and 3 inches apart, the holes opening toward the screen and upward at an angle of about 45° . When the air is turned on, an apparently solid mass of bubbles will arise along the whole surface of the screen. With this arrangement the screens will run hours or even days without any attention, whereas without the air-jet one or more men are employed keeping the screens clean, and many fry are unavoidably killed by being forced against the screens and by the work of the men in keeping them free. The thorough aeration of the water thus indirectly accomplished is very beneficial when large numbers of fry are passing over, and double the number can be safely handled in troughs thus equipped.

At Put-in Bay the fry are planted as soon as hatched. They are dipped from the fry tanks into kegs, in which they are transported to the natural spawning-grounds on the reefs; each keg containing 50,000 to 100,000 fry, according to the distance to be traveled. If they are to be taken any considerable distance, fresh water is kept running on them. If the facilities are such that the fry can be held in tanks until they attain a length of an inch before being planted, they would be

better able to take care of themselves than if deposited at an earlier stage. In the spring of 1896, about 1,000 whitefish fry were held in one of the station troughs until late in April, with no other food than the entomostraca and other minute life which came into the troughs with the water pumped from the lake. They grew considerably and were remarkably active. Cannibalism was of frequent though not of general occurrence; toward the close of the period through which the fry were held, numbers could be seen which had seized others by the tails and swallowed as much of the bodies as possible, which was, of course, but little. In every case one of the larger had attacked one of the smaller, the victim being dead and his destroyer swimming about actively with the body of the dead fry trailing along his side. If these fry had been regularly supplied with food, it is not probable that cannibalism would have occurred.

REARING IN PONDS.

There have been few attempts to raise whitefish in ponds on a large scale, but experiments lead to the belief that under favorable conditions whitefish can be raised in artificial ponds to some extent. Of course an abundance of good cold water, suitable ground for the construction of deep ponds, and convenience to railroad communication would be essential to success.

A successful experiment in this direction was begun at Northville in 1882. The fish were treated as young trout are, being fed wholly on liver. Three-year-old whitefish, artificially reared, yielded a large number of eggs, a fair percentage of which were fertilized. Fish weighing from 3 to 4½ pounds, that had never been fed on anything but liver, were plump and healthy. Similar successful experiments have been made in Europe with one of the native whitefishes (*Coregonus lavaretus*).

The most noteworthy experiments in the rearing of whitefish in ponds have been conducted by private enterprise at Warren, Indiana. The following account of the work will be of interest:

In 1890, 50,000 whitefish fry, obtained from the Sandusky station of the United States Fish Commission, were placed in a pond 20 by 40 feet, having a maximum depth of 5 feet. In November of the same year 864 whitefish, averaging 7½ or 8 inches in length, were taken from the pond. This result was not considered satisfactory, although the conditions were not favorable, as there was no natural food in the pond and no artificial food was regularly supplied, the fish feeding on various kinds of food thrown into the pond from time to time. The fish kept near the bottom, and were never seen from the time of planting to the time the pond was drawn.

In 1891, half a million eggs obtained at Toledo were hatched with a loss of about 30 per cent, and the resulting fry, together with a small number procured from Put-in-Bay station, were planted in a pond containing the small whitefish previously mentioned. This pond was 65 by 65 feet and 12 feet deep. It is supposed that practically all the fry were devoured by the larger fish. Prior to the time of planting the young whitefish the older ones were very inactive and seldom seen, but as soon as the plant was made they became very active, and for a period of two weeks, about sunset, they could be seen leaping and darting up out of the water after the fashion of black bass chasing minnows.

In the following season the fry were placed in pens in a pond. Confervæ formed in the ponds, clogging the screens, and the water got so warm that the fry, which were dying rapidly, were placed in the pond with the large fish.

In 1893 the experiments were more encouraging. About 120,000 fry were placed in a new pond, 200 feet square and from 2½ to 14 feet deep, supplied with 25 gallons of running water per minute at the lowest stage. Fifty thousand fry were held in a small tank at the hatchery, so that their habits, food, etc., could be studied. This afforded more instruction than all former experiments combined. Before the umbilical sac was absorbed the fry began to take the prepared food, and as soon as the sac was entirely gone they ate freely. They grew rapidly and did well until the middle of May, when, the weather being very warm, the temperature of the tank rose to 63° F., resulting in the death of some of the fry and necessitating a removal of the remaining fry to the pond containing the other fry of the same age. These fry were from 1 to 1½ inches long when put in the pond. They had been fed on nothing but very finely divided gluten, a product of wheat, of a yellowish-white color, very even in size and semi-buoyant. The floating property of this food is supposed to be very important, as the whitefish when young do not feed on the bottom, which is their habit when older. Any part of this food which settles on the bottom must be removed, as it is liable to ferment and rise to the surface, when, if the fry eat it, they will die.

For the purpose of removing the fry to another pond the large pond was drawn in November of the same year in which they were hatched. A large seine was completely filled with fish at the first haul. Being very delicate, a great many were killed before efforts could be made to move them. It is estimated that nearly 50,000 of these young whitefish were lost. They were from 7 to 9 inches long, being about 8 months old. Several thousand were saved which are now (1895) 2½ years old. When 2 years old 70 were caught, which measured from 16 to 18 inches long.

When the fry are about an inch long they are fed on a stiff dough made of fine middlings. This food is placed on the bottom of the tank and all that is not consumed is removed. This is also the sole food of the adult whitefish. It is placed in water shallow enough so that the fish-culturist may see if it is all consumed during the night, the fish feeding exclusively at that time. If all is not eaten, a less quantity is given for the next day, as a matter of economy and to prevent the pollution of the water.

It has been found that in the raising of fry the temperature of the water should not go above 55° F., and that 65° is fatal, while fish three or four months old will stand a much higher temperature.

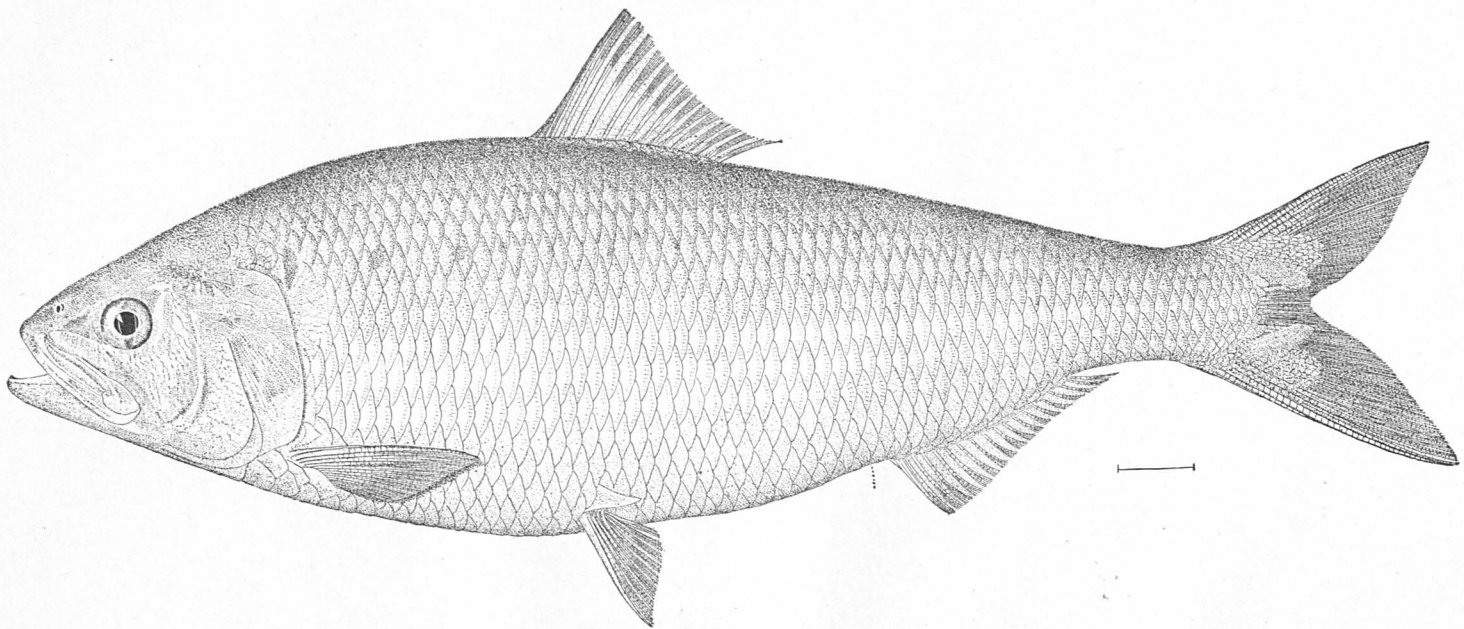

ALOSA SAPIDISSIMA. *Common Shad.*

THE SHAD.

DESCRIPTION OF THE SHAD.

The shad (*Alosa sapidissima*) is the largest, best-known, and most valuable member of the herring family in the United States. The body is deep and compressed, the depth varying with the sex and spawning condition, but averaging about one-third the body length. The head, contained about $4\frac{1}{2}$ times in the body length, is quite deep; the cheek is deeper than long. The jaws are about equal, the lower jaw fitting into a deep notch on the tip of the upper. Teeth are present in the young, but are not found on the jaws in the adult. The eye is contained $5\frac{3}{8}$ to 6 times in the length of head. The gillrakers are long, slender, and numerous, there being from 93 to 120 on the first arch. The fins are small and weak, the dorsal containing 15 rays and the anal 21. The lower edge of the body is strongly serrated, the plate-like scales numbering 21 before the ventral fin and 16 behind it. The scales in the lateral line number 60. The body is dark-bluish or greenish above, silvery on the sides, and white beneath. There is a dark spot behind the gill-opening and sometimes a row of smaller spots along the side. The vertical fins often have black or dusky edges. The peritoneum is white. Supposed structural and color peculiarities in shad from different regions or basins have not been verified.

From the other clupeoids with which the shad is frequently associated in the rivers, it may be readily distinguished. In all of them the cheek is longer than deep. The hickory shad or hickory jack (*Pomolobus mediocris*) has a projecting lower jaw and a very straight profile. The river herrings or alewives are much smaller than the shad, have fewer and shorter gillrakers, and a larger eye ($3\frac{1}{2}$ in head). In the branch herring (*P. pseudoharengus*) the peritoneum is pale, while in the glut herring (*P. astivalis*) it is black.

The female shad is larger than the male, the average difference in weight being more than a pound. The mature males taken in the fisheries of the Atlantic coast weigh from $1\frac{1}{2}$ to 6 pounds, the average being about 3 pounds; the females usually weigh from 3 to 6 pounds, the average being $4\frac{3}{4}$ pounds. The general average for both sexes is between $3\frac{3}{4}$ and 4 pounds. In the early history of the fisheries, shad weighing 11, 12, and even 14 pounds were reported, but 9-pound shad are very rare on the Atlantic coast, and 10 pounds seems to be the maximum. Some seasons an unusual number of large shad (7 to 9 pounds) appear in certain streams. On the Pacific coast shad average a pound or more heavier than on the Atlantic, occasionally attaining a weight of 14 pounds; many have been reported weighing 9 to 12 pounds.

DISTRIBUTION AND ABUNDANCE.

The shad is distributed along the entire east coast of the United States, and northward and eastward to the Gulf of St. Lawrence. It has gradually spread from the Sacramento River, California, where it was introduced by the California Fish Commission, and is now taken from southern California (Los Angeles County) to southeast Alaska. In the early history of the country its abundance excited unbounded astonishment. Nearly every river on the Atlantic coast was invaded in the spring by immense schools, which, in their upward course, furnished an ample supply of good food. Notwithstanding greatly increased fishing operations and the curtailment of the spawning-grounds, the supply in recent years has not only been generally maintained, but owing to fish-cultural efforts has been largely augmented in certain streams, notably in the Kennebec, Hudson, Delaware, Susquehanna, Choptank, Potomac, Nanticoke, Rappahannock, York, James, Chowan, Roanoke, Neuse, and St. Johns rivers, and in Chesapeake Bay, Albemarle Sound, Croatan Sound, and Pamlico Sound, and the Sacramento and Columbia rivers.

SHAD IN THE OCEAN.

The shad passes most of its existence at sea, and little is known of its habits and movements when out of the rivers. The ocean areas to which it resorts are unknown, and what its salt-water food consists of has not been determined. In the Gulf of Maine it is known to associate in large numbers with mackerel and herring during the months of June, September, and October, being most numerous in June. It has been taken at North Truro, Massachusetts, in the fall, when the ocean temperature was from 43° to 49°. In the month of November, one year after another, it has been found on the west side of Sakonnet River, Rhode Island. In May and June it has been captured with mackerel a few miles northeast of Cape Cod Light. Some instances of capture indicate that under certain conditions the adults may remain in the fresh-water rivers a whole year. In November, 1890, 600 were taken in the Chesapeake Bay. It has been found in the Potomac in considerable abundance in August and September, and even during the last week in December. Its movements are largely controlled by the water temperature. It is believed that it aims to occupy a hydro-thermal area of certain temperature; that its migrations are determined by the shifting of this area, and that this temperature is between 60° and 70°.

SHAD IN THE RIVERS.

The annual migration of the shad from the ocean to the rivers is for the sole purpose of reproduction. It ascends to suitable spawning-grounds, which are invariably in fresh water, occupying several weeks in depositing and fertilizing its eggs in any given stream.

Its migrations from the sea are in quite a regular succession of time with relation to latitude. It first appears in the St. Johns River,

Florida, about November 15, the season of greatest abundance being February and March. In the Savannah River, Georgia, and the Edisto, South Carolina, the run begins early in January and ends the last of March. In the North Carolina rivers these stages of the migration are a little later. In the Potomac River advance individuals appear late in February, but the fish is most numerous in April. In the Delaware River the maximum run is about the 1st of May. It reaches the Hudson River the last of March, and is found in the Connecticut toward the end of April, is most abundant the last of May, and leaves the stream late in July. In the Kennebec and Androscoggin rivers, Maine, it is first taken in April and has left by the middle of July. In the St. John River, New Brunswick, it appears about the middle of May, and in the Miramichi River, New Brunswick, late in May.

The main body of shad ascends the rivers when the temperature of the water is from 56° to 66°, the numbers diminishing when the temperature is over 66°. Successive schools enter the Potomac from February to July, the males preceding the females. Of 61,000 shad comprising the first of the run received at Washington, D. C., from March 19 to 24, 1897, 90 per cent were males. Toward the close of the season males are extremely scarce.

The movement of the shad up the rivers is not constant, but in waves, causing a rise and fall in the catch. In some of the rivers the fishermen claim that a fairly well-defined run occurs late in the season, consisting of a somewhat different fish, known as "May shad."

The erection of impassable dams along the rivers and streams was probably the first thing to curtail the natural spawning-grounds of these fish and to seriously check their natural increase.

As shad enter the rivers only for the purpose of spawning, the fisheries are necessarily prosecuted during the spawning season, and often upon the favorite spawning-grounds. The increase of population necessitates a larger supply of fish and requires the use of more apparatus, and the number of shad that reach fresh water is therefore greatly curtailed by assiduous fishing with all kinds of contrivances in the estuaries and in the mouths and lower parts of rivers. Under these conditions of a restricted spawning area and increased netting shad would soon be exterminated without artificial propagation; or the fishery, at least, would greatly diminish and become unprofitable. Such a crisis was fast approaching in 1879, when the Fish Commission entered upon systematic work in shad propagation.

From their birth until their return to the rivers shad are preyed upon incessantly by other fish, so that the larger portion of the young do not survive their few months' sojourn in fresh water, and of those which leave the rivers each season probably not one in one hundred reaches maturity to deposit its eggs and contribute to the perpetuation of its species. In the rivers striped bass, white perch, black bass, and other predaceous fishes devour the young, and when they reach salt water, sharks, horse-mackerel, kingfish, etc., undoubtedly destroy many

adults. It has been observed by North Carolina porpoise fishermen that as the shad swim close along the shore the porpoises follow and feed on them till they pass into fresh water. In the rivers the adult shad is comparatively free from enemies.

To what extent the pollution of the waters has reduced the numbers of shad is not known, but acids, sawdust, garbage, oils, gas tar, and refuse from dye-works all tend to make the water of rivers unsuitable for them.

FOOD.

After entering the rivers, the shad takes but little, if any, food previous to spawning, but after casting its eggs it bites at flies or any small shining object, and has been known to take the artificial fly. The mouth of the adult is practically toothless, and its throat contains no functionally active teeth. The water which passes through the branchial filter—the gillrakers—is deprived of the small animals which are too large to pass through its meshes. It is a common remark with fishermen and others that food is rarely found in the stomach of the adult shad in fresh water, but examinations have shown that the shad does, in some instances, eat small crustacea, insects, etc. The only substance commonly found in its stomach in fresh water has the appearance of black mud. It is held by some that the shad swims with its mouth open and may unintentionally swallow the small organisms found in its stomach under such circumstances, but as far as observation of fish in aquaria and experiences of net fishermen go, the shad does not swim with its mouth open.

NATURAL SPAWNING.

Shad are liable to be ripe anywhere above brackish water, and under favorable temperature conditions spawn wherever they happen to be, but in some river basins they exhibit a well-defined choice of spawning-places, preferring localities below the mouths of creeks, where the warmer water of creeks mingles with the colder channel water. The shad lays its eggs during the highest daily average temperature, a condition realized about sunset, when the warmer shoal water commingles with the colder channel water, establishing a balance. The principal spawning occurs from 5 p. m. to 10 p. m. Observations on the Potomac River show that of the eggs from shad caught in a seine only 11 per cent were taken between midnight and noon, the percentage in the morning being 14 one year and 8 another.

The eggs in the ovaries remain in a compact mass until they ripen, at first occupying but a small space, but gradually increasing until they distend the whole abdomen, the average weight of the ovaries being about 13 ounces. Close examination at the approach of the spawning time will disclose large maturing eggs of rather uniform size and others smaller and of variable size. Whether the latter are the forming eggs for the next year, for two or three succeeding years, or for the lifetime of the fish has not been determined, nor is it known whether shad spawn every year. The small and shrunken ovaries of a spent fish are still

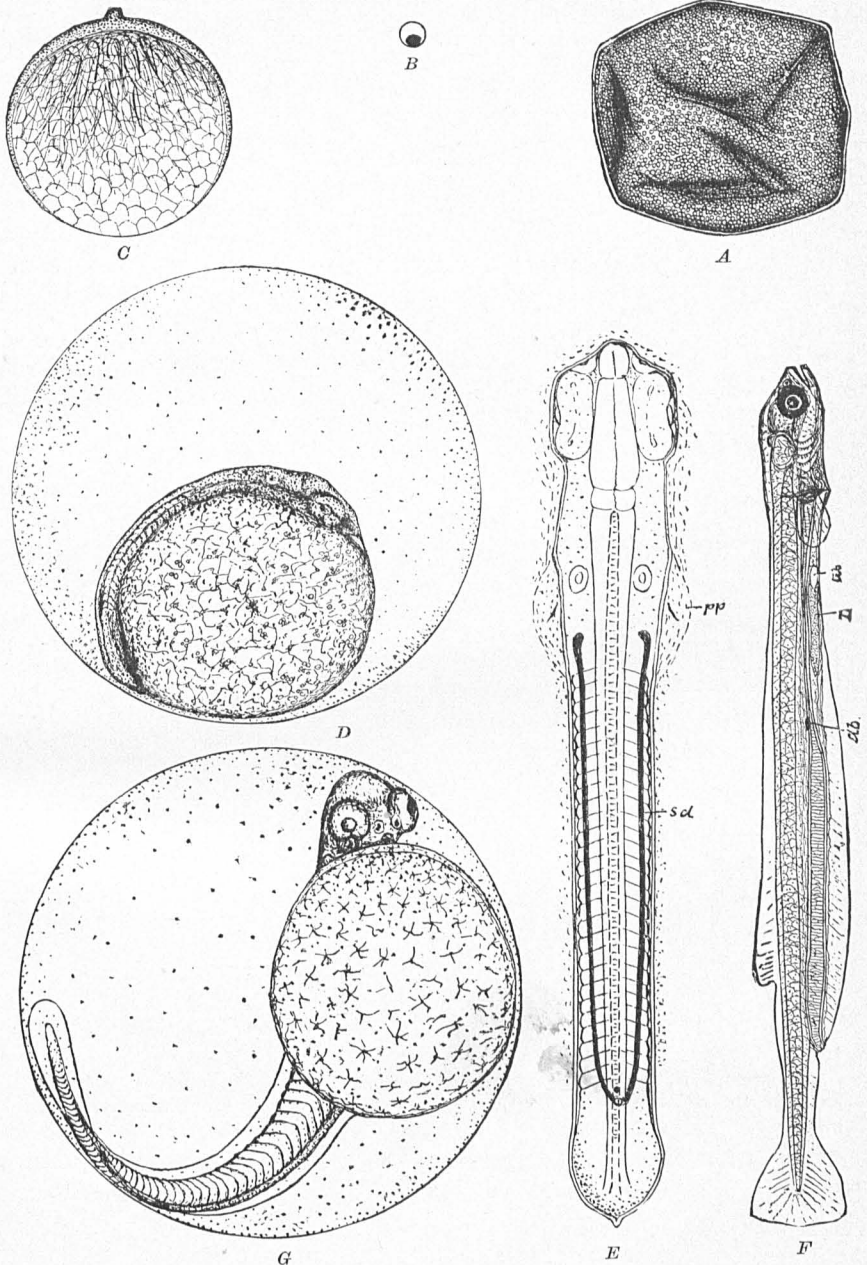

A. Freshly extruded egg enlarged, showing its envelope much wrinkled and its surface covered with small round vesicles.
 B. Shad egg, showing vitellus and distended egg-membrane, natural size.
 C. Shows the gradual accumulation of germinal matter at one pole of egg, the polar prominence externally, and presence of plasmic processes extending down through the vitellus.
 D. Embryo shad in its natural position in its spacious enveloping membrane. From a photograph.
 E. Diagrammatic representation of an embryo to show course of segmental ducts *sd* and extension outward of pectoral plates *pp*, which are intimately concerned in the development of pectoral fins.
 F. Side view of a young shad 13 days old, viewed as a transparent object. *ab*, rudimentary air-bladder; *L*, liver; *Gb*, gall-bladder.
 G. An embryo in its envelope, on the third day of development, nearly ready to hatch.

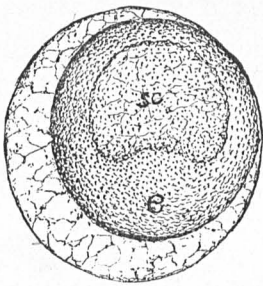

H

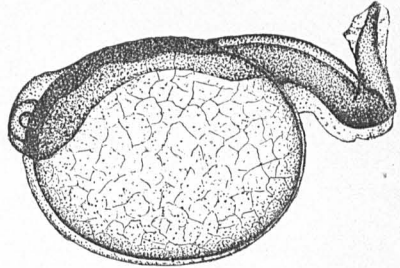

K

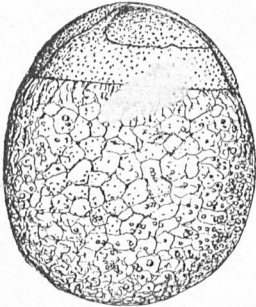

I

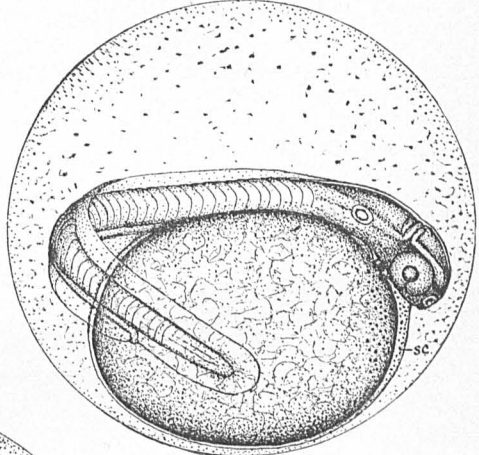

M

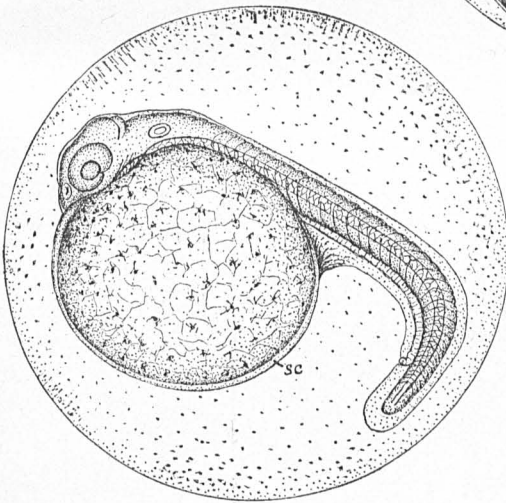

L

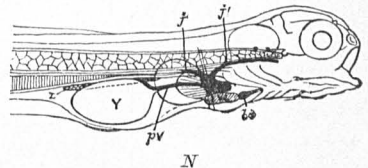

N

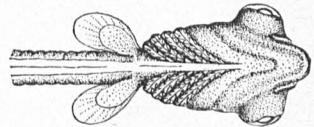

O

H and I. Two views of an egg after the blastoderm has spread considerably and the embryonic area *e* is well defined.
 K. View of unbatched embryo, which developed in a temperature of 45° F., producing distortions of tail and notochord.
 L. An egg-envelope with its contained embryo, forty-four hours after impregnation, viewed as a transparent object.
 M. An egg-envelope with its contained embryo at the beginning of the third day of development. From a photograph.
 N. Anterior portion of a young fish on fourth day. To show relations of liver *L* to yolk *Y*, over which the portal vessel *pv* passes forward to empty into the venous sinus, in common with the anterior and posterior jugulars *j'* and *j*, *ba* bulbus aortae, *ve* ventricle.
 O. View of fore part of a young fish 17 days old, from ventral side.

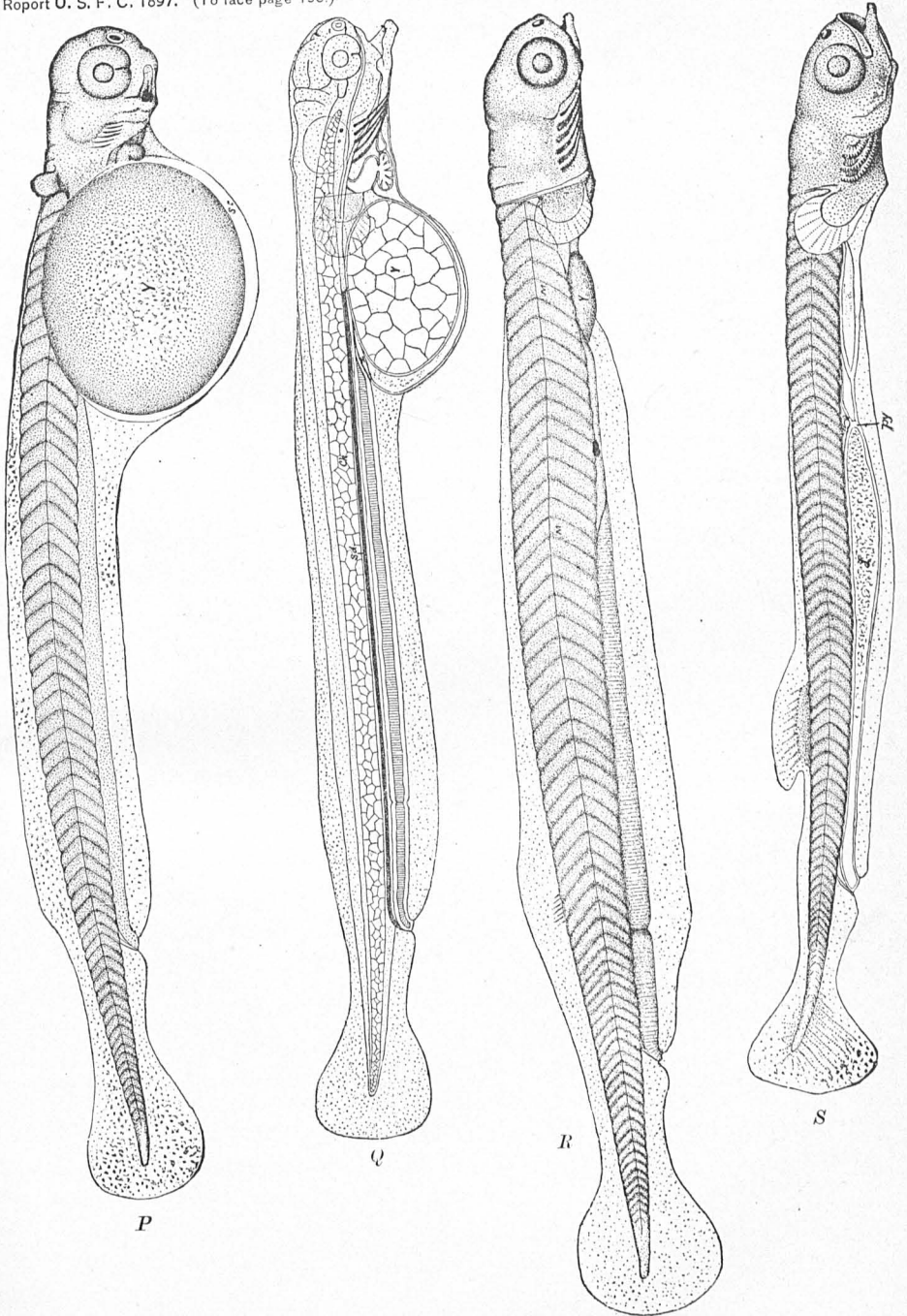

P. Young fish immediately after hatching, viewed as an opaque object and somewhat obliquely from one side, to display the relations of branchial and hyomandibular arches, and position of pectoral fin.
Q. Young fish third day after hatching, viewed as a transparent object to show extension of segmental duct forward; chorda *ch.*, and liver *L.*
R. Young fish 5 days after hatching, very much enlarged, and viewed as an opaque object. Only a slight remnant of the yolk-sack *Y* remains.
S. Young fish 17 days after hatching, viewed partly as an opaque and partly as a transparent object; *py* pylorus and rudimentary air-bladder above it; *I* intestine, filled with the remains of ingested food. The opercula are already so far developed as partly to conceal the branchia.

found full of these eggs of different sizes. Shortly before spawning, transparent eggs of large size, contrasting strongly with the opaque golden hue of less mature ones, will be found scattered through the still compact ovarian mass, and becoming more and more numerous, the ovaries disintegrate, the eggs fall apart, and extrusion begins, a liquid stream of eggs and mucus flowing from the oviduct on the slightest pressure of the abdomen.

Freshly deposited shad eggs are of a pale amber or pink color, and are transparent. They are about $\frac{1}{4}$ inch in diameter and somewhat flattened and irregularly rounded in form. The egg membrane is much wrinkled and lies in close contact with the contained vitellus. Immediately after fertilization the egg becomes spherical through the absorption of water and apparently gains very much in bulk, measuring from $\frac{5}{8}$ to $\frac{7}{8}$ inch in diameter; but this gain is only the distended egg membrane, the vitellus or true germinal and nutritive portion not having increased. The vitellus is heavier than water, and a large space filled with fluid now exists between it and the membrane, the vitellus rolling about and changing its position as the position of the egg membrane is altered. No adhesive material is found on the outside of the membrane, though when first extruded the eggs are covered with a somewhat sticky ovarian mucus.

In a state of nature the shad deposits its eggs loosely in the rivers without building a nest, the two sexes running along together from the channel towards the shore, and the eggs and milt being ejected simultaneously. On quiet evenings, at the height of the season, spawning shad may be heard surging and plunging along the shores. By fishermen this is termed "washing."

Shad are very prolific, but much less so than many other food-fishes. The quantities of eggs taken by spawn-takers do not represent the actual fecundity, for many are cast in advance of stripping. The average number is not more than 30,000. Single fish have been known to yield 60,000, 80,000, 100,000, and 115,000 eggs; and on the Delaware River, in 1885, one yielded 156,000. Many eggs fail to be fertilized, and but a comparatively small percentage of those impregnated are hatched. After being extruded, the eggs sink to the bottom, where they remain until hatched, subject to the attacks of fish and other water animals. Eels are very destructive to shad spawn and often attack shad caught in gill nets, devouring the undeposited eggs and sometimes mutilating half the catch of a gill net fisherman.

The development of fungus is one of the greatest dangers to shad eggs in a natural state, and another potent agency for their destruction is the mud brought down by heavy rains, burying and suffocating the eggs.

After spawning, shad are denominated "down-runners," "racers," and "spent fish." They are then very lean and hardly fit for food, but they begin to feed and have become fatter by the time they reach salt water in the summer or fall.

YOUNG SHAD.

In the Middle States the young fish remain in the rivers, feeding and growing, until the cool weather of fall comes on. They then begin to drop downstream, and by the last of November have passed out into the ocean or bays, and are lost sight of until they come back three or four years after, full-grown and ready to spawn. They leave the Potomac River when the water falls to about 40°. By that time they are about 3 inches long. For the last two or three years they have been observed in great abundance about Bryan Point, feeding and jumping out of the water about sunset. They keep within the open streak of water between the shores and the water-grass which covers the flats, in water 2 to 5 feet deep. After mild winters young shad have been found in the Potomac River in April, 30 miles above brackish water and 160 miles from the ocean, associated with young alewives and sturgeon. Some immature shad, apparently 2 years old, are caught each year in seines operated in the fresh water of the Potomac River, and undersized shad are frequently caught in the New England rivers, where the tidal waters are of little length.

COMMERCIAL VALUE.

The shad is one of the most palatable and popular of fishes. Its flesh is rich, but not oily, and the roe is considered a delicacy. It is the most valuable river fish of the Atlantic coast, and, next to the Pacific salmon, the most important species inhabiting the fresh waters of North America. In every Atlantic State from New Jersey to Florida, inclusive, it is the most valuable fish, and in New York it is second only to the bluefish. Among all the economic fishes of the United States only the salmon and cod exceed it in value, and, considering all branches of the fishing industry, only the whale fishery and the oyster fishery, besides the foregoing, are financially more important than the shad.

In 1896 the shad catch of the Atlantic seaboard numbered 13,145,395 fish, weighing 50,847,967 pounds, and worth to the fishermen \$1,656,580. The value of the shad catch of the Pacific States in 1895 was \$5,600, a sum representing 366,000 pounds.

EARLY ATTEMPTS AT SHAD-CULTURE.

The systematic development and extension of shad-culture were undertaken with the definite purpose of testing the value of artificial propagation in maintaining an important fishery which was being rapidly depleted. As early as 1848 shad eggs were artificially taken and fertilized, and in 1867 more extensive experiments were made on the Connecticut River, and later on the Potomac, with encouraging results. The attention of many States was thus attracted to the work, and in 1872 it was taken up by the general government. Prior to the experiments on the Connecticut, certain species of the salmon family had been principally dealt with in fish-culture, and different methods from those in use were necessary for shad-hatching, owing to the less specific gravity of shad ova and the much shorter period of time required for the development of the fish from the egg.

The "Seth Green box," a modification of the floating-box used for hatching trout and salmon eggs, was first tried with great success, but floating-boxes were subject to various accidents when used in tidal waters, and in rapid succession devices of various kinds were brought forward to supplant them. The most important were hatching-cones and the plunger-buckets, which, though imperfect, rendered larger operations possible. At this period the apparatus was arranged on flat-bottomed barges and towed from point to point along the coast from Albemarle Sound to the Susquehanna River, a slow and expensive method. The Chase whitefish jar worked with considerable efficiency, but required modifications, and finally the "universal" hatching-jar now in use was adopted in 1882.

During the years of experimental work from 1872 to 1880, 97,471,700 shad fry were planted, beginning with 859,000 in 1872, while in 1880, 28,626,000 were distributed. Prior to 1880 deposits of a few hundred thousand each were made in as many different streams as possible, but the increased production of young fish made it possible to ship and plant the fry by the carload, and by 1884 shad-culture was established on a large scale, barge operations were abandoned, and the work conducted on shore. The basins of the Chesapeake Bay and Delaware River had meanwhile been selected by the United States Commission as the natural seat of operations, though the State commissions from Massachusetts to South Carolina were actively engaged on their own account. At present the States, except Connecticut, New York, Pennsylvania, and Maryland, have practically abandoned shad-hatching, leaving the work to the general government.

EGG-GROUNDS.

Every river on the Atlantic coast from Massachusetts southward has been examined by the agents of some State commission or the United States, or by both, in order to determine the natural spawning-grounds of the shad. On nearly every stream hatcheries have been operated at one time or another, but usually eggs were not obtained in sufficient numbers to justify continued operations, except in the Chesapeake and Delaware basins. However, it is not unlikely that after further investigation it will be found practicable to maintain hatcheries on rivers which have long since been abandoned. It is certain that work on the Albemarle Sound can be successfully conducted, and though operations on the Hudson River have not been on a large scale, better results may be there obtained in the future.

In certain river stretches, apparently favorable, no ripe fish are found; for example, in the Roanoke River for 15 miles above its mouth, where 10,000 to 15,000 shad are taken annually, mature eggs can not be found, though the fish spawn just below there, as they do many miles above at Weldon. In the Sutton Beach seine, the one in North Carolina waters which has afforded the most spawn, only about one spawning shad to each 100 is caught, and the annual catch of this seine is 30,000 to 75,000 per annum. In view of such facts, it is not remarkable that difficulty

has been experienced and time consumed in deciding on permanent locations for hatcheries.

The spawning period varies widely in different seasons; in some years shad are numerous and in spawning condition two or three weeks after the time when they have ordinarily disappeared. They deposit eggs at some point along the coast for six continuous months.

The following streams have been occupied by hatcheries, as some of them are now, and it will be observed that the approximate spawning periods, beginning early in the South, become gradually later toward the North.

Waters.	Place.	Period.
Edisto River.....	Jacksonboro, S. C.....	Mar. 5-26.
Albemarle Sound.....	Avoca, N. C.....	Apr. 1-30.
Potomac River.....	Below Washington, D. C.....	Apr. 15 to June 10.
Susquehanna River.....	Below Havre de Grace, Md.....	Apr. 17 to June 15.
Delaware River.....	Gloucester, N. J.....	May 10 to June 20.
Hudson River.....	Below Albany, N. Y.....	May 15 to June 30.
Housatonic River.....	Birmingham, Conn.....	Do.
Connecticut River.....	Holyoke, Mass.....	June 15 to July 5.
Merrimac River.....	North Andover, Mass.....	June 1 to July 15.

The United States Fish Commission operates stations at Bryan Point, 12 miles below Washington on the Potomac, and at Battery Island at the mouth of the Susquehanna, while the steamer *Fish Hawk*, fitted up as a floating hatchery, is engaged during the shad season on the Delaware River. These two stations and the vessel can receive respectively 16,000,000, 40,000,000, and 12,000,000 eggs. On more than one occasion each has been taxed to its utmost capacity, but as the average hatching period is 8 days, and three of the special cars of the Commission are hatcheries in themselves and capable of taking 2,000,000 to 4,000,000 eggs aboard at a time, the hatcheries can be quickly relieved in case of emergency.

In 1896 the total number of the shad eggs collected was 149,822,000, yielding 93,481,500 fry. In 1897, owing to expansion of operations at old stations and prosecution of work in new waters, 205,000,000 eggs were taken, from which 134,545,000 fry were hatched. The aggregate number of shad fry planted by the Commission to and including the year 1897 was over 1,375,000,000.

The methods herein described are those in use on the Potomac, where the eggs collected at Bryan Point are shipped to Washington and there hatched in Central Station.

Potomac River.—The Potomac River, immediately adjacent to Fort Washington (12 miles below Washington, D. C.), is probably more productive of ripe shad than any other area of the same size. This was discovered as early as 1880, and a station was soon developed there with steam pumps, tank, and hatching vessels. The seine operated at this point between 1887 and 1891 furnished 23 per cent of all eggs from the river.

In March, 1892, the station was removed 2 miles lower down the river to Bryan Point, on the Maryland side, opposite Mount Vernon. As the eggs can be more safely and economically transported than the fry, they are promptly transferred to Central Station at Washington, where the hatching is done, and the fry are sent out to the various rivers on the cars of the Commission, a side-track at Central Station permitting them to be brought close up to the building.

The following table, taken from the records of the station, shows the value of the spawning-grounds:

Years.	Number of eggs taken.	Years.	Number of eggs taken.
1880.....	20,749,000	1889.....	58,233,000
1881.....	43,200,000	1890.....	35,202,000
1882.....	21,800,000	1891.....	32,980,000
1883.....	24,274,000	1892.....	13,446,000
1884.....	19,000,000	1893.....	9,423,000
1885.....	22,576,000	1894.....	32,393,000
1886.....	36,362,000	1895.....	66,065,000
1887.....	59,435,000	1896.....	64,788,000
1888.....	81,177,000	1897.....	39,707,000

In 1889 immense collections of eggs were made on certain days—8,368,000 on May 6 and 6,311,000 on May 7, and during seven days there was an average of over 5,000,000 per day. This was before and just after a freshet.

To increase the supply of eggs, seine fishing has been attempted by the United States Fish Commission on both the Susquehanna and the Potomac, but the efforts were only partially successful and were finally abandoned. The extension of egg-taking by seines can not be relied upon, especially as this method of fishing has been declining for many years, owing to its greater expense, and a corresponding growth has taken place in the gill-net fishery. It is often difficult to obtain the ripe eggs from a seine on account of the great numbers of alewives taken at the same time.

The following comparative table shows the shad-egg production from a Potomac River seine, together with the proportion of males, females, and spawning fish, and the number of eggs per fish:

Year.	Total number of eggs obtained.	Total ripe fish.	Total shad caught.	Per cent of males.	Per cent of females.	Average number of eggs per fish spawned.	Per cent ripe.
1887.....	20,956,000	652	10,348	71.4	28.6	32,100	6.3
1888.....	22,657,000	688	11,212	69.2	30.8	32,900	6.1
1889.....	17,738,000	612	6,217	52.3	47.7	28,980	9.8
1890.....	10,262,000	468	4,606	54.3	45.7	21,900	10.1
1891.....	5,276,000	228	3,138	57.1	42.9	23,140	7.2
Average.	15,377,000	530	7,104	60.8	39.2	27,800	7.4

Had all other fisheries furnished an equal percentage of eggs, the annual Potomac collections would have reached about 300,000,000. But while the Fort Washington seine, with a catch of 10,000 shad, gave 20,000,000 eggs, and another, capturing 18,000, gave 17,000,000, a third catching 60,000 shad, gave only 1,000,000.

Eggs taken by gill fishermen are usually superior to those from seines, and the gillers attach enough value to the market for eggs to save almost all within reach. At the commencement of the season many of them secure spawning-pans, which they keep in their boats, taking and fertilizing the eggs themselves, and when accidentally overlooked by the regular spawn-takers they sometimes row several miles to bring in pans of eggs. In 1896 a giller who laid out his net with the special object of securing spawning shad, caught 3,300 fish and sold over 6,000,000 eggs to the Commission. About 1,100 of his fish were roe shad; of the total, about 6 per cent were ripe; of the 1,100 roe, about 20 per cent were ripe.

The average catch of shad by the gillers who supply eggs is 1,600 to 1,800 per season; but they do not all operate specially for the capture of spawning fish, though this work is profitable and gillers are fast turning attention to it. The Fort Washington gilling boats furnish on an average about 1,000,000 eggs each a season, those at White House 400,000, Sandy Bar 350,000, Greenway 300,000, and Craney Island 150,000, the average being about 500,000 per boat.

Susquehanna River.—The shoal water in the neighborhood of Battery Station is an extensive and valuable spawning-ground. The station is conveniently situated on an island and the possibilities in egg-collecting appear to be almost unlimited. Hundreds of gill fishermen are engaged and large seines are operated within easy distance. In 1886 the station was overrun with eggs; 170 universal hatching-jars and 58 cones would not contain them, large numbers being held in cylinders, buckets, and pans. In 1888 over 105,000,000 were taken, and in 1889 7,600,000 were obtained in one night. Both egg-collecting and hatching are carried on, and the establishment is complete in itself. There is no transfer of the eggs except for occasional car shipments, and the fry are carried to Havre de Grace in 10-gallon cans for railroad transfer to the places of deposit.

The collections at this station amounted to 45,983,000 eggs in 1896 and 71,000,000 in 1897.

Delaware River.—The steamer *Fish Hawk* has been employed in shad-hatching on this river nearly every season since 1887, the egg-collecting and other labor being performed by the crew. An interesting feature of the work is the large yield of eggs per fish. Eggs from this river have been saved regularly since 1887 from seines, but the available product among the gill fishermen has never been fully ascertained.

The eggs collected by the *Fish Hawk* numbered 37,874,000 in 1896 and 66,708,000 in 1897.

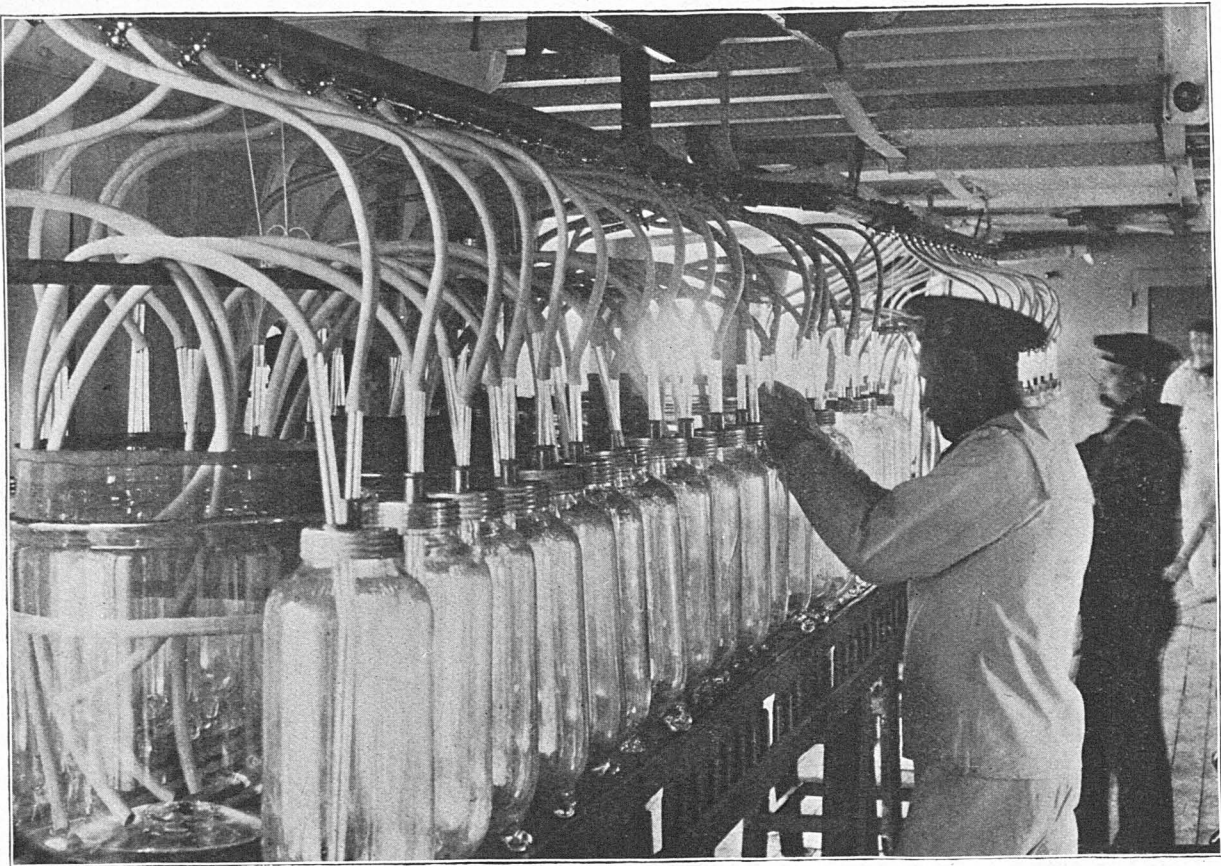

MAIN DECK OF THE STEAMER FISH HAWK, EQUIPPED FOR HATCHING SHAD.

EGG-COLLECTING.

Collecting eggs is the work of experienced watermen, who must be prepared to endure all kinds of weather in open boats. The boats are towed out to the fishing-grounds by steam-launches, where the spawn-takers visit the nets of the market fishermen, obtaining from them the spawning fish. After eggs have been obtained a ticket is dropped into each panful, with the date and the name of the fisherman, for entry on the books of the station. The price for eggs is always above the market price of the shad, and payment is made at the end of the season on the basis of 28,000 to the liquid quart, the price being \$10 to \$20 per 1,000,000. On the Potomac 40 to 50 spawn-takers are employed at the station, besides 12 or 15 men who are engaged as hatching attendants, machinists, firemen, and cooks.

The spawn-taker uses a 16-foot flat-bottomed bateau and is provided with a lantern, six small and four large spawn pans, and a dipper of 1-quart capacity. The pans are made of tin and are of two sizes, 11-inch and 18-inch diameters, the latter with handles. The smaller are for receiving eggs on delivery from the fish, and the larger for carrying them. The pans are thoroughly washed each night after use and not allowed to become rusty or indented. The dippers are round-bottomed, hold nearly a quart, and have handles with open ends, with 5 inches of the free end wrapped with seine twine. To obtain eggs from a seine, double the above number of spawn vessels may be required.

Spawn-taking tubs of indurated wood fiber have been introduced in Potomac River operations and found superior to tin, being without hoops or joints, non-corrosive, and non-conductors of heat. They have wood covers which fit inside the rims, and the tops fit tightly by means of a soft rubber joint: 4 inches of the central part of the cover is cut away to admit air.

As the shad manipulated are sold and consumed in a fresh state, fishermen waste no time in transferring them to market boats, which are in waiting, and rapidity of execution is therefore required on the part of the spawn-taker, who must be alert and exact in his methods.

In gill-net fishing there is usually ample time to assort the fish, which are taken into the boat one at a time, except when sudden squalls or exceptional captures force the premature hauling in of the net with the fish wound up in the meshes. Unskilled spawn-takers are liable to the mistake of stripping eggs without having the necessary milt to impregnate them, for several spawners may be taken over a period of ten or twenty minutes without the capture of a male fish. In such cases (of great frequency late in the season) the female fish must be placed conveniently, backs down, to prevent the eggs from running out, and the males may have to be obtained from other boats. When ripe shad are taken in seines, two or three large baskets should be in readiness to receive them.

Sometimes the number of ripe fish will be sufficient to occupy all the attention that can be devoted to them; at other times the run of fish

is greatly reduced by local conditions. Even when other conditions are satisfactory, if neither high nor low water occurs about sunset but few ripe fish are caught. The large seines land toward the last of the ebb tide, and gill net fishermen can do nothing except on the change of the tide—on slack water. The fish spawn at a certain time of day, and when taken at other hours are not in spawning condition. Thunderstorms sometimes occur for days in succession about sunset, the very hour when most disastrous.

A scarcity of male fish toward the end of the season often cuts short operations when eggs are plentiful. Unsuccessful attempts have been made to capture the males at such times by using gill nets with meshes smaller than those in the nets of market fishermen. Attempts have been made to pen the adults, but without success, as the fish become diseased and their eggs spoil within them. In gill nets the adult is entangled in the mesh and can not escape by struggling, and it therefore remains comparatively quiet.

The quality of shad eggs is generally impaired where the fish are held for an hour or more in trap nets or seines. The eggs from fish taken in large seines are usually of bad quality, but those from short seines, which are landed quickly after the fish have been surrounded, are usually good; and those from trap nets, in which the fish have been held for some hours, are valueless. Eggs are rarely susceptible to fertilization longer than 20 minutes after the fish are taken from the water, though there are exceptions to this rule. On May 23, 1895, Potomac shad were stripped which had been out of the water about $1\frac{1}{2}$ hours; they were kept separate, and at the end of 48 hours produced 100,000 eggs, which yielded 98,000 fry.

The shad dies very quickly after capture and is immediately responsive to electrical storms, the catch of seines and nets of all kinds falling off promptly when a thunderstorm develops. Even in seines already laid out in the water, with lead line on the bottom, there is an appreciable decrease in such event. On the Delaware River, May 29, 1887, nearly 50 per cent of the shad eggs on board the steamer *Fish Hawk* perished during an electrical storm which continued from 6 p. m. to midnight. There were 4,481,000 eggs with embryos well formed, and without perceptible change in water temperature 1,918,000 were killed, many turning white by 8 p. m.

Heavy freshets cause an abrupt suspension of fishing, but the effect of a single freshet is usually temporary. The shad which have gone above are backed down before the muddy water, but reappear upon its outward passage. An occurrence of this kind will effect a great increase in egg receipts if the water temperature before muddy water comes is suitable. The shad that were scattered above being thrown back in a body, reascend in a body.

A season of clear water is undesirable both for fishermen and hatching work, as the fish see the nets and avoid them, gill nets being put out only on the night tide and half the fishing being thus lost. The water

should be discolored enough to prevent the fish from seeing the nets, but not thick, say from 10 to 20.* An occasional freshet reduces the temperature and prolongs the season; however, with an equal number of fish in the rivers, clear water is probably more advantageous for natural increase, as a large proportion of naturally deposited eggs must perish from suffocation under the mud in seasons of freshet.

THE WEATHER AND SPAWN.

The development of eggs within the ovaries is hastened by heat and retarded by cold. In a warm season fish ready to spawn are more numerous early in the season than in a cold one, and the period for obtaining them is apt to close earlier. The eggs, not only after they are deposited and impregnated, but before they leave the body of the fish, are affected by the temperature of the water, often being "blighted" or "rotten ripe." This phenomenon was observed as far back as 1873. It occurs on the water reaching 80° to 81°, or with a rapid rise. On the other hand, a sudden fall in temperature has been observed to arrest natural spawning, produce blighted eggs, and to destroy those in the hatching-vessels. Continued low temperature is also disastrous to fishing.

An abnormally inferior quality of the Potomac River eggs was noticed during the full period of operations in 1896. The bulk of the run of shad made their appearance on a rapidly ascending temperature, and the eggs were injured within the parent fish, more than half perishing before conversion into fry. The rise in temperature was greater than had been recorded in the eleven years preceding. The run of shad increased proportionately, the catch at one seine increasing from 100 to 800 in 24 hours. A snowstorm on April 7—morning air temperature 35° F. and mean air temperature 46°—was followed by heavy frost on April 9, the morning air temperature on the last-named date being 34°. The river water on April 10 was 46°, rising to 48° on April 12 and to 71° in the afternoon of April 21, thus gaining 25° in 10 days. After April 21 the catch of shad fell off to such an extent that fishing was no longer profitable.

The water of the Potomac early in March is usually of a temperature of 36° to 40°, rising to 52° to 58° about the middle of April, when the spawning period begins, and at the end of May, the close of the period, it averages from 65° to 70°.

STRIPPING AND FERTILIZING THE EGGS.

In stripping the eggs the shad is lifted with the right hand and caught above the tail with the left. All slime and loose scales are removed by going over the fish two or three times in quick succession with the right hand. The head is carried to the left side under the

*The condition that permits the discernment of objects at a distance of 10 to 20 inches beneath the water surface, the method of registration employed by the Washington (D. C.) aqueduct office.

arm and there retained by the arm, the tail being bent slightly upward with the left hand. When the fish is properly adjusted its head is nearly concealed. The fish is held firmly over a moist pan, and with a moderate downward pressure of the right hand the eggs will flow freely if mature. The strokes are continued until there are signs of blood, which usually accompany the last eggs. The fingers should not touch the gills of the fish, as laceration of these organs causes a flow of blood injurious to the eggs. Two fish may be stripped into each pan.

As soon as the spawn is all obtained, the shad is discarded, it being impossible to preserve the life of such a delicate fish, even with the utmost care. But though it has slight tenacity of life when taken from the water, the shad is a very muscular fish, and if not firmly held it will flounder and splash in the pan of eggs and probably throw a large proportion out and damage some of those that remain.

The first half teaspoonful of eggs should be pressed out into the palm of the left hand and inspected. Skilled operatives can usually discern ripeness by general outward appearance. A slow and yet almost positive test consists in running some of the eggs into water, when, if dead, they will have the appearance of boiled rice. But bad eggs are sometimes beyond the detection of the most skilled fish-culturists. If the eggs are white, opaque, or of milky appearance, the fish is put aside. Immature eggs are white, small, and adhering in clots; or they may be transparent and yet unyielding to pressure. The former are valueless, while the latter can sometimes be utilized by putting the fish aside to soften. Both ripe and green eggs sometimes occur in the same fish, but only expert operatives can hope to take the one and leave the other. If eggs are mature, but little pressure is necessary to start them, and if not, they are only injured by squeezing, and will either not flow at all, or will come away with difficulty in clotted masses and generally with a little blood. After the spawn is taken away, the fish has a soft and flaccid appearance about the abdomen, which after natural spawning becomes contracted and drawn up, tapering slenderly toward the tail.

Eggs of the best grade may be impaired by intermixture of overripe or green ones, lumps of milt, tissues of the sperm sac, or fish scales. The overripe and unfertilized ones can be discarded, and a tiny net, an inch square, or a straw or twig, may be used in removing foreign substances. The spawn-taker should clean the eggs before delivering them at the hatchery, and no subsequent care can compensate for his neglect. Experienced men rarely bring in bad eggs, unless as a result of variable and unfavorable weather conditions.

To obtain the milt the spawn-taker catches the fish by the back, taking hold of the under side with the right hand. Without relaxing pressure at any point the milt is forced out with the thumb and forefinger. Good milt is so thin that it flows in a steady stream, and from some fish it can be ejected widely over the surface of the eggs, but in

fish which have been dead some minutes the milt is lumpy and flows only in drops. A teaspoonful will fertilize 40,000 to 75,000. After the milt has been applied, from half a pint to a pint of water from the river is added and the pan given a slow rotary motion, continued till the milt is thoroughly mixed, when a milky appearance is imparted to the water. When the river water is turbid, clear water must be obtained before work is commenced.

In gill-net boats eggs thus treated will expand without further immediate attention, for there is sufficient motion from the boat to prevent clotting; shad eggs do not "cement" when the milt is applied to them, as in the case with salmon and trout eggs; but they adhere, and if left perfectly quiet, as on shore, a large proportion will be lifeless. Those comprising the lower strata may either lack sufficient expansive power to absorb water under weight of the others, or in the suction of each separate egg, in the natural tendency to absorb water, they may have a cupping effect upon one another, thus preventing water contact. Whatever the cause, they stick together in one mass, and only those of the upper layers receive sufficient water; the others remain undersized and die. Large quantities of eggs must be separated, either by agitating the water already in the pan or by the addition of more.

In one minute after thorough mixing the milt can be washed off with safety, but usually several pans are to be looked after, when the milt may be allowed to remain 5, 10, or even 15 minutes. After the last pan of eggs has been fertilized, they are rinsed, beginning with those first taken, by pouring in a quart of water, placing the edge of the dipper so that the stream is directed between the eggs and the sides of the pan, as the eggs may be injured if the water is poured directly upon them. Then the pan is oscillated, the water being drained over the edge slowly, and, the operation being repeated, the third quart of water is left upon the eggs. The eggs must be well stirred with the inflowing water.

There need be no fear of applying too much milt. The amount obtained from one fish may be ample for the eggs from two, but it is always better to employ two males. Eggs may look promising for two or three hours, yet never expand to full size or produce fish. They lie at the bottom, and underneath any good ones which may be in the pan; they stick to the fingers, while the good ones will not, nor can they be successfully removed from hatching-jars until after several days' decomposition. By using two pans, good eggs may be separated from bad by pouring, but the process is slow and there is usually no time in the hatcheries for such operations.

Good eggs are very transparent and so soft and light that they are not apparent to the touch when the fingers are moved among them. When the temperature is about 70°, no change is observed for about 12 or 13 minutes after the milt is added, but about this time a careful movement of the fingers in the pan discloses their presence, and in a

little more than 20 minutes from the time the milt is applied they feel like shot against the fingers, and to an experienced eye are observed to increase slightly in size; when a day old, they will not break if dropped to the floor. In transferring to other vessels, the rim of the smaller pan should be gently immersed beneath the water surface in the larger one, and the pouring take place gradually. To prevent splashing, in boats, a small pan should be put on the water surface of the larger pan. Sudden jars must be avoided, all foreign substances excluded, and the pans be free from grease and salt. After the application of milt they expand to full size in 20 to 60 minutes, depending partly on temperature, and at this stage they may be doubled up in the larger pans, the question of safety in moving them being determined by their hardness.

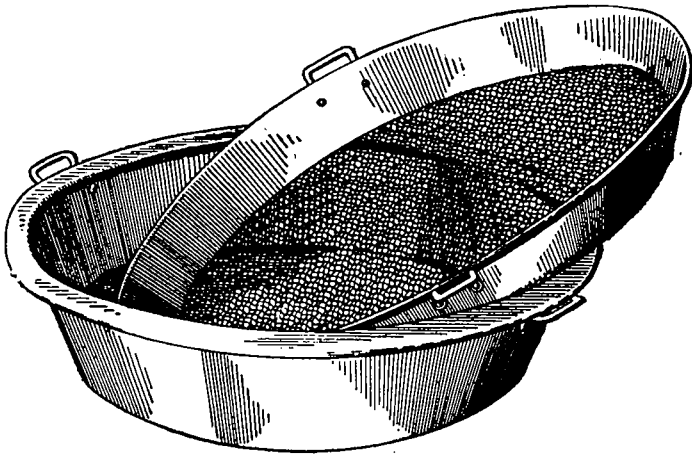

Pans used in cleaning eggs.

When eggs are received at the station, in order to thoroughly remove all impurities they are passed through netting, and for this purpose, two 18-inch flared tin pans with handles, one pan fitting within the other, are employed; 2 inches of the bottom part of the inner pan are evenly cut off and replaced with quarter-inch (bar) twine netting. The lower pan is filled with water to a point just above the netting, and then several quarts of eggs are gently poured in, when they drop through the meshes, leaving the fish scales, etc., behind. Thus they are also given a change of water, which should be clean and fresh and of about the same temperature as that in the hatchery and river.

If the eggs have absorbed sufficient water in the spawn-pan, they swell and adhere to each other, forming a compact mass, and are ready to be transferred to the hatching-jars, but if they are not sufficiently expanded or "water-hardened," they must remain in the pans, from 30 to 60 minutes being required for their full expansion.

HATCHERIES AND EQUIPMENT.

The building for a shad-hatchery may be of a temporary character, as it is used only about two months each year, but ample light, space, ventilation, and arrangements for moderate heating are necessary. The steam boiler and pumps should be in a separate structure.

In exceptional cases, as at Central Station, in Washington, river water from city pipes can be utilized. If the water supply is taken directly from the river the suction should be put below low-water mark, and the end provided with a strainer and kept off the bottom to avoid sediment. The water should be supplied from an open tank, not by a force-pump, but if it is taken from municipal pipes a regulator may be employed. A fall of 16 feet is desirable, or 8 pounds pressure per square inch at the top of the hatching-jars. The amount required is 2 quarts per minute to each jar.

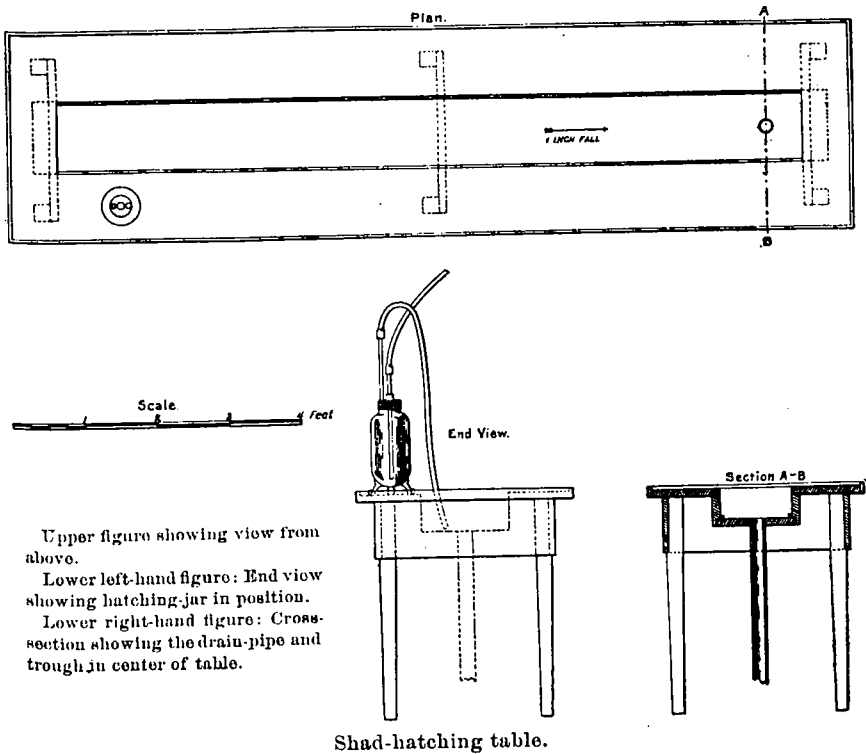

Upper figure showing view from above.

Lower left-hand figure: End view showing hatching-jar in position.

Lower right-hand figure: Cross-section showing the drain-pipe and trough in center of table.

Shad-hatching table.

The jars are arranged on tables, as shown in the cut. From a large iron pipe, branch piping of 1½ to 2 inches diameter is run over each table, where ½-inch brass pet-cocks are inserted 6 inches apart. The jars are connected with the supply-pipes by half-inch rubber tubing. Tight drains are required to carry away the waste water. Collector-tanks for fry are rectangular and may be of glass or wood, the former possibly preferred.

The overflow from the collectors is guarded by a wire gauze or cheese-cloth strainer. A safe and interchangeable device consists of a stout wire frame, over which a cheese-cloth bag is drawn and tied. A $\frac{3}{4}$ -inch rubber hose is attached to the opening in the frame. The strainer is put inside among the fry, and the outflow in an overflow cup. The overflow cup is set at the proper height to control the water level in the collector-tank. Long-handled nets of $\frac{3}{16}$ -inch mesh are required to remove egg lumps or other matter from the jars.

THE AUTOMATIC HATCHING-JAR.

The United States Fish Commission, in the development of its work, had presented to it the necessity of dealing with the eggs of the

whitefish and the shad upon a scale unprecedented in the history of fish-culture. Millions were to be handled instead of thousands, and the removal of dead eggs by hand picking was no longer to be considered. After successive experiments the McDonald automatic hatching-jar was devised, and it is now generally employed.

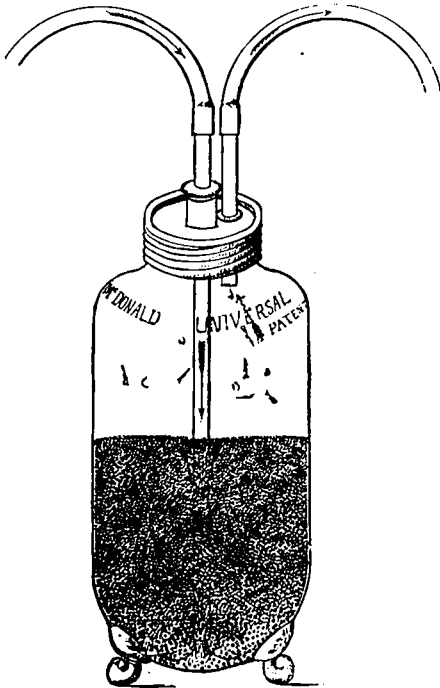

Automatic shad-hatching jar.

hatching. The cleanliness of the apparatus is also advantageous, and as the material of which it is made is glass, the progress of development can be watched satisfactorily from the outside of the jar with a hand glass or pocket lens of moderate power.

The jar consists of a cylindrical glass vessel, of 7 quarts' capacity, with hemispherical bottom, supported upon three glass legs. The top is made with threads to receive a screw-cap. It is closed by a metallic disk, perforated with two holes five-eighths inch in diameter—one in the center admits the glass tube that introduces the water into the jar, the other, equally distant from the central hole and the edge of

The most meritorious feature of this apparatus is that it prevents the development of the saprolegnious fungus, which caused so great a mortality in some other forms of hatching contrivances in which all the ova were not in continual movement. The very gradual, gentle, and continual rolling movement of the ova upon each other in the jar apparently prevents the spores of the fungus from ad-

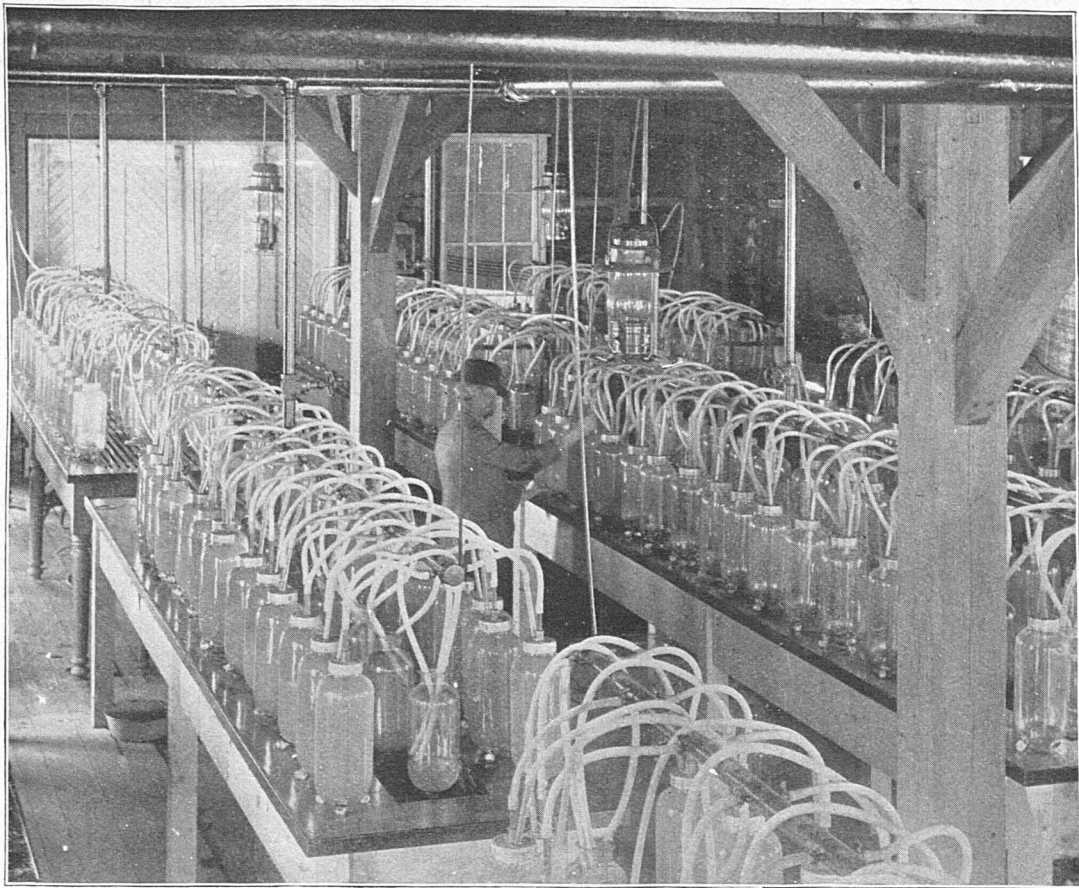

INTERIOR OF HATCHERY AT BATTERY STATION, EQUIPPED WITH HATCHING-JARS.

the metal plate, admits the glass tube which carries off the waste water. The central tube is connected by half-inch rubber tubing with the pet-cock, which regulates the supply of water. A groove in the inner surface of the metallic plate carries a rubber collar, and when the plate is in place the tightening of the metallic screw-cap seals the opening hermetically. Both the inlet and outlet tubes pass through stuffing-boxes provided with gum-washers and binding-screws. The central or feed tube is provided with stuffing-boxes, one on the top of the disk and one on the bottom, the better to hold it to a true center. The outlet tube is provided with only one stuffing-box, and the binding-ring is beveled.

In preparing the jar for work the side tube is fitted first. The glass tube should be wet, the gum-washer slipped on the tube about an inch from the end and introduced into the opening. Holding the tube perpendicularly to the face of the plate, press fairly on the tube, and the washer, rolling on itself, will fall into the seat provided for it. Screw on the binding-ring, and test by seeing that the tube slides freely back and forth in the stuffing-box; if not, it should be refitted with a heavier or lighter washer, as may be required. Glass tubes can not be procured of absolute uniformity in size. Water is the only lubricant that should be used about the jar fittings.

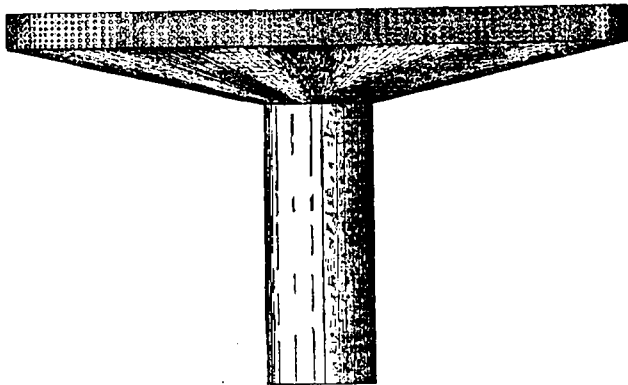

Egg Funnel.

The jar, after being washed clean, is filled with fresh water. A shallow tin funnel with a perforated rim is inserted, so that the water will stand as high in the funnel-throat as possible, and the eggs are poured in by dipperfuls, or when taken from transportation trays are washed in by a jet of water. Care is used to have the eggs fall but a short distance, and no fish scales or other foreign matter should enter the jar with them, as the presence of anything but water and eggs renders a proper motion of the mass impossible, and usually results in the loss of a large proportion of the eggs. The requisite number of eggs, 80,000 to 100,000, being in the jar, it is put in position and closed, care being taken that both the inlet and outlet tubes slide freely in their stuffing-boxes. If the tubes become gummed, let water trickle down around the binding-screws. To close the jar, turn on the water, place the feed-tube in the jar, turning off the water immediately after the feed-tube has passed beneath the surface of the water in the jar,

thus expelling all the air from the feed-tube; otherwise it would rise in bubbles, throwing a portion of the eggs out through the outlet-tube.

With a proper quantity of semi-buoyant eggs in the jar and the water turned on and regulated, the movement of the current establishes a regular boiling motion in the mass of eggs, which brings each in succession to the surface. This motion may be regulated without altering the quantity of water. By loosening the upper binding-screw of the central stuffing-box, and pushing the feed-tube down until it almost comes in contact with the bottom of the jar, the motion of the eggs is increased. If the jar is working properly, the dead eggs when brought to the surface remain on top, forming a distinct layer, and by pushing down the outlet tube a suitable distance they are lifted up by the escaping current and taken out.

When the water is turned on for the first time the jar should be watched closely until a regular motion has been established. When eggs have stood 15 or 20 minutes in the jar before the water is turned on they do not readily yield to the boiling motion, but tend to rise in a solid mass to the top of the jar. By quickly starting and stopping the current the mass is readily disintegrated. The degree or intensity of motion of the eggs varies not only with their age and condition, but also with the condition of the water. If the water is muddy, the motion should be rapid enough to prevent mud settling either on the eggs or in the bottom of the jar. Ordinarily the best motion is that which readily brings the dead eggs to the surface. After the hatching has progressed far enough to dispose of a portion of the eggs there is less resistance to the current, and it should be reduced by shutting off part of the supply or by slightly lifting the central tube. If the motion is not reduced from time to time as the hatching progresses, shells will be carried over into the receiving-tank with the fish and, being very light, will be drawn against the outlet screen, causing an overflow. The motion should be so gentle at the time of the greatest hatching as barely to induce the fish to swim out of the jar and leave their cast-off shells behind.

Very healthy eggs, exposed to bright direct sunshine, hatch so rapidly that the combined effort of the swarming mass of young fish will establish sufficient current to draw some shells over into the receiving-tank. This may be modified by placing a screen between the jar and the light. The shells under normal conditions remain and form a cloud-like layer above the mass of working eggs. As they accumulate they should be removed by shoving down the outlet-tube until they are drawn up with the escaping water. A good plan is to draw several jars in succession into a large pan, whence any fish coming over with the shells may be ladled into the receiving-tank.

A remnant of eggs may be long in hatching, and they should be poured into a large, clean, bright pan and exposed to bright sunlight, when they will hatch in five or ten minutes.

If the connection of the jar must be broken, it is essential that the rubber feed-tube does not drop down and siphon the eggs from the jar.

In reconnecting, the air may be expelled with the metal top screwed down in position. To effect this, draw both glass tubes up to the top of the jar and turn on a full head of water, when the air will be forced out in bubbles above the eggs, the bubbles escaping through the outlet tube. The central tube is now restored to its former position. The automatic action permits entire separation of bad from good eggs, though some days may be required to accomplish the full result. The dead become lighter from gases arising from decomposition. A net, small enough to easily enter the mouth of the jar and fixed to a handle several inches longer than the jar, is convenient for removing particles of foreign matter.

Shad eggs are semi-buoyant, and those which will not rise commence lumping on the third or fourth day. The usual period of hatching is from 6 to 10 days, sometimes longer, according to temperature of water, but with high temperature they will hatch in 3 days. Fry hatched in less than 5 days are usually, though not always, weak. In general, the period of incubation varies inversely with the prevailing temperature, but continuous dark and cloudy days will retard and strong light will accelerate development under precisely the same conditions of water temperature, and other circumstances not well understood may also have their influence.

Fry when hatched are about 0.37 inch long. They have been measured at intervals of from 5 to 15 days, from late in May to the middle of October. Toward the middle of August the rate in growth diminishes. When 9 days old they are about 0.62 inch long. Fry 0.5 inch long July 20th were 0.75 inch long 8 days later; on August 14th, 2 to 2.25 inches; September 20th, 3 to 4 inches; October 1st, 4 to 4½ inches; November 4th, 5 to 7 inches. Some years they grow faster than others, and in some streams more rapidly than in others. From the State fish-pounds at Raleigh, North Carolina, 33 were removed in November, 1884, which measured 8 to 9 inches. Their usual size in the Potomac in the fall is 3 to 4 inches.

MEASURING THE EGGS AND FRY.

To estimate the number of eggs and of the young fry was for years rather a difficult matter to accomplish satisfactorily. The standard made use of at the outset was undoubtedly much too high. The scale most used at present is a light square, made of wood, the longer leg being 15 inches and the shorter 7½ inches long. The material is ½ inch wide and ¼ inch thick. The graduations are on the longer leg, and read from the lower end upward. The first line is at a height corresponding to the level attained in the jar by a measured half-pint of water, and the succeeding lines are determined by the introduction of additional half-pints of water. When the scale is being constructed, the central glass tube is stopped at the lower end that it may displace an amount of water equal to the amount of eggs it will displace in

practice. Each line on the measuring stick registers 7,000 shad eggs. The number of eggs in a liquid pint is established by actual count. Those which are very young or have been lately on trays are not of normal size and not qualified for measurement. The eggs are at rest when measured.

The jar contents are determined by placing the short leg of the measuring-stick over the top, with the other pointing downward and touching the side of the jar. The number is indicated on the scale at the point opposite the surface of the bulk of the eggs. Scarcely any semi-buoyant eggs die, under proper conditions, after hatching out has commenced, and a close approximation to the number of fry may be obtained from the last measurement, which is made after the careful removal of all dead eggs and the bursting forth of the first young.

FEEDING AND REARING.

The young shad swims vigorously, by rapid and continuous vibration of the tail, from the moment it leaves the egg. It is colorless, transparent, and gelatinous. Several hundred in a dipper are scarcely discernible. It has a relatively large yolk-sac, but supports it with ease during the first four or five days after hatching, the small quantity remaining after this time not being visible externally, although found in shad fry 14 to 16 days old. Minute conical teeth make their appearance on the lower jaws and in the pharynx about the second or third day after hatching. The jaws at three months are armed with teeth slightly curved.

Young shad feed on other minute organisms, such as exceedingly small crustaceans. Food has never been observed in the alimentary canal until ten or twelve days after the young fish had left the egg. At about the middle of the second week considerable may be seen, but the intestine is then not often very densely packed. At the age of three weeks an abundance of food is

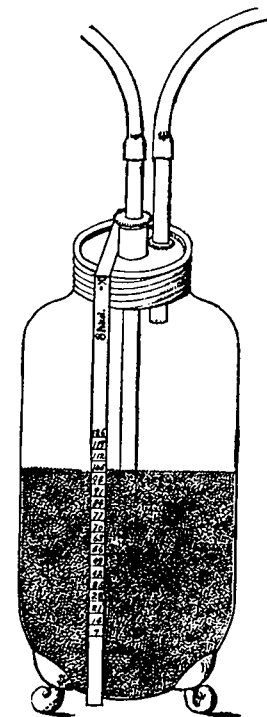

Application of a measuring scale to a jar of shad eggs.

found. They have been known at this early age to eat their own kind, and later the young carp and salmon. When cold, raw winds drive the crustaceans into deeper water, the young shad follow them, and in aquaria they take crustacea freely. In salt-water aquaria they may be fed upon chopped oysters and canned herring-roe.

Experiments with young shad have been carried on for several years at Central Station in salt-water aquaria. On one occasion about 250 were received in October, at which time they were about five months old. They were put in brackish water, specific gravity 1.005, which

was added to from day to day for nearly a week, when it was brought up to 1.018, or the same specific gravity as the water used in the marine aquaria. At the time these were placed in the brackish water others were put into fresh-water aquaria, but the latter died within three days. Those in salt water began in two or three days to take food, consisting of chopped oysters, clams, and beef, the preference being for oysters. At first they would take food only when it was sinking, later they began taking it off plants where it had lodged, and finally from the bottom. Nearly all remained healthy, plump, and active for six months, some living until about midsummer.

For ten years past two or three million shad fry have been reared annually at the Fish Ponds, Washington, D. C. A 6-acre pond is used, the water supply being taken from the city water-works. The depth varies from 2 to 3 feet, and throughout the whole extent there is a dense growth of water-plants, among which crustacean food multiplies—new supplies being brought in from the water-pipes. Fingerling shad are so tender that the numbers annually liberated can not be ascertained; they can not withstand the handling consequent upon counting them, not even undergoing transfer in dippers of water, and their scales drop off on being touched; consequently at high tide they are liberated into the Potomac through a sluice-gate with an outlet pipe about 2 feet in diameter. They require some days to make their escape. By conservative estimate 50 to 60 per cent are held safely until about October.

Rearing has been experimentally tested at Wytheville and Neosho with good results. At Neosho on the 3d of June, 1892, 700,000 fry were received from Gloucester, N. J.; their growth was satisfactory. In preparing for their release the hatchery branch was cleared of shoals, drifts, and aquatic plants for three-quarters of a mile, and early in November, when the branch was swollen with rain water, 200,000 6-months-old fish were allowed to pass through open gates; they were some hours in escaping, in a continuous silvery mass. These were the first fingerling shad planted in waters tributary to the Gulf of Mexico.

TRANSPORTATION.

Good, healthy fry will pass from the jar to the collector-tank as fast as hatched, and unless too thick will not lie on the bottom of the tank, although they sometimes crowd on the side nearest the strongest rays of light. As many as 500,000 to 800,000 are collected in each tank. In transporting, they must be kept in vessels with smooth surfaces, preferably tin-lined cans. Zinc vessels are destructive, and galvanized cans are not recommended.

About 2,000 to 3,000 fry are put to a gallon of water, which must be pure enough for ordinary drinking purposes and well aerated. The water in the cans must be kept at 58° to 65°, though in rivers and ponds the fry endure a temperature of 90° F.

As early as 1874, experiments were carried on to retard the development of eggs, in order to provide a longer period between the delivery

of the eggs from the parent fish and the absorption of the yolk-sac. Eggs, when transported, were placed on trays and put under melting ice, and later experiments have been conducted inside refrigerator boxes. Pathological changes or deformities are induced in the embryos when subjected to too low a temperature or when held long enough on damp flannel trays (ordinary air temperatures) to hatch.

It would appear that 55° to 53° is the lowest temperature in which ova will safely undergo their normal development and 9 days is the longest period of incubation attainable at that temperature—time sufficient, when added to the several days required for the young to absorb the yolk-sac, to ship them to Europe, which has so far failed. One drawback is the rapid development of fungus, which grows over the eggs, penetrates the membranes, and kills the ova.

Retardation of the hatching of shad eggs has not been turned to practical account, but eggs can be transported hundreds of miles on trays, large numbers being moved at a relatively small expense compared with the same number of fry.

Eggs from the Potomac River are sent to Washington, a distance of 12 miles, by steamer, and nearly a mile over cobblestone streets in Washington. Formerly they were put on the trays soon after being taken, but in April, with night air-temperature as low as 49°, and in June, with the relatively high temperature, the quality was bad; they did well between 60° and 65°, and later they were put into hatching-vessels and kept in motion 12 hours, when they became hard, and went forward in better condition. Since 1888 they have been retained in hatching-jars for 36 hours preceding transfer.

They are shipped in crates of 20 shallow trays, the frames of the latter being of wood with bottoms of wire mesh about 8 to the linear inch. Wood and wire are painted with asphaltum. Each tray is covered with cheese-cloth, somewhat overlapping the edges, the cloths being hemmed, to avoid ravelings. There are two frames of wood, connected with leather straps; one the base and the other the cover for the stack of trays. The trays, after being filled with eggs, are wrapped in a long, cotton-goods apron and strapped together. There is an iron handle on the top frame, and the lowermost tray is put down empty with the wire surface upward. Then follow the trays containing eggs, the uppermost one being put on empty with the wire surface up. The top and bottom trays are merely to protect the others.

The greater part of the water above the eggs is poured off from the jars and the remainder poured into tin pans along with the eggs. The cloths, after soaking in water, are arranged one by one on the trays and tucked closely into the four corners. The trays are stacked up and eggs poured evenly over the surface of the top one with a large dipper, and each tray, when filled, is put on the crate base. The surplus water drains away to the manipulating table. Tray cloths of material too closely woven to let the water through are unsuitable. The eggs are bailed up in dippers with the water that they are in, and

usually spread two layers deep, but can be put on more thickly. When eighteen trays are filled they are wrapped in the outer cloth, previously soaked in water, and tightly buckled together. The crate covers and tray cloths are boiled in water each time after use.

Each tray—14 by 19 inches area, with two layers of eggs—holds about 20,000 eggs, the contents of a full crate representing from 300,000 to 400,000 eggs. While in transit the crates are sprinkled with river water on the sides at least once an hour, and kept in the shade, away from the cooling influence of the wind, to preserve even temperature.

TRANSPLANTING.

The propagation of shad is mainly carried on to maintain or increase the supply in rivers where the species is native, and the fry are liberated with that end in view; but the shad has also been planted, in some cases with great success, in waters in which it was either unknown or found in small quantities. Large numbers of fry have been liberated in tributaries of the Gulf of Mexico, but without marked results. Between 1873 and 1892 several million fry were experimentally placed in the waters of Great Salt Lake, Utah Lake, and Bear Lake, Utah.

From 1884 to 1886, 3,000,000 fry were liberated in the Colorado River at the Needles, in Arizona. It was believed that the shad would be permanently confined to the Gulf of California by the warm water of the lower part, and would then return to the Colorado and Gila rivers to spawn. The time having gone by when the adults should return, the experiment is regarded as without result. It has been found that the shallow waters at the mouth of the Colorado River are barren of life and the conditions are unfavorable to stocking that river with shad.

Remarkable success attended the stocking of waters of the Pacific Coast northward from Monterey. In 1871, 12,000 shad fry from the Hudson River were liberated in the Sacramento River by the California Fish Commission, and in 1873 the United States Fish Commission made a second deposit of 35,000. Subsequent plants in the Sacramento, aggregating 609,000, were made by the United States Commission from 1876 to 1880. From these small colonies, amounting to less than 1 per cent of the number now annually planted in the Atlantic Slope rivers, the shad have multiplied and distributed themselves along nearly 3,000 miles of coast from southern California to southeastern Alaska.

The shad rapidly made their way up the coast from San Francisco Bay. They reached Rogue River, Oregon, in 1882. In the Columbia a few were taken as early as 1876 or 1877. About 1881 or 1882 they were on the coast of Washington, reaching Puget Sound in 1882. They appeared in the Fraser River, British Columbia, in 1891; and in the Stikine River, near Wrangell Island, Alaska—latitude 56° 30'—the same year. The species now is found along the entire coast from Los Angeles County, California, to Chilkat, Alaska, covering 22 degrees of latitude. Its distribution, considered from the standpoint of commercial importance, is from Monterey Bay to Puget Sound.

On the northern part of the coast the first fry were introduced in 1885, the number being 60,000. Of these, 50,000 were put in the Willamette River and 10,000 in the Snake River. In the following year 850,000 were introduced into the Columbia River, making a total of 910,000.

The increase has been uninterrupted and rapid in California waters, and the shad is now one of the most abundant fishes of that State. As a result of the liberation of the first two consignments, consisting of 45,000 fry, several thousand mature shad were caught in 1879, and sold in the San Francisco market. In 1880 specimens of all sizes were taken in the Sacramento River and Monterey Bay, and it was evident that the shad had begun to multiply. Up to 1883 the increase was marvelous. Prohibitory law did not prevent their incidental capture in salmon nets, their abundance being thus indicated.

The shad is most numerous on the west coast in San Francisco Bay and its tributaries. It is not common above Sacramento, owing to the low water-temperature. In the Columbia it is regularly found as far as the Cascades, about 150 miles above the mouth of the river. Contrary to their habit in eastern rivers, shad are found in the rivers tributary to San Francisco Bay and the coastal waters of that vicinity throughout the year.



BATTERY STATION HATCHERY, HAVRE DE GRACE, MARYLAND.

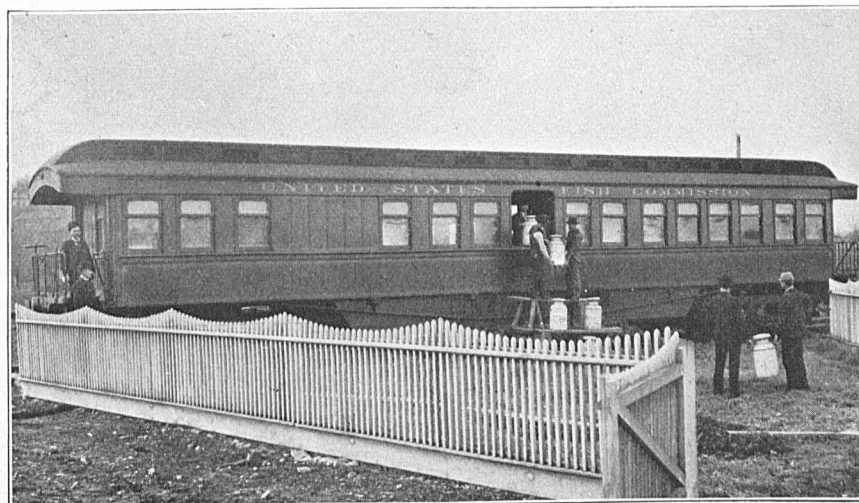

U. S. FISH COMMISSION CAR LOADING AT NEOSHO, MISSOURI.

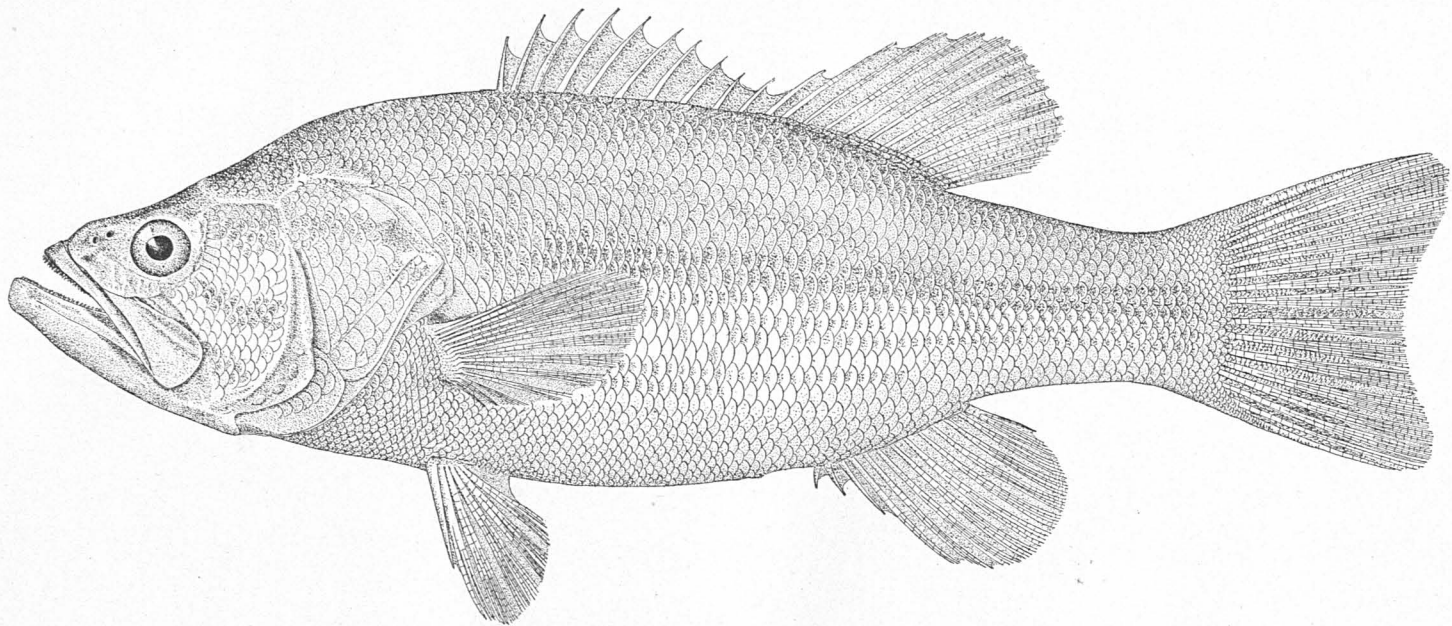

MICROPTERUS SALMOIDES. *Large-mouth Black Bass.*

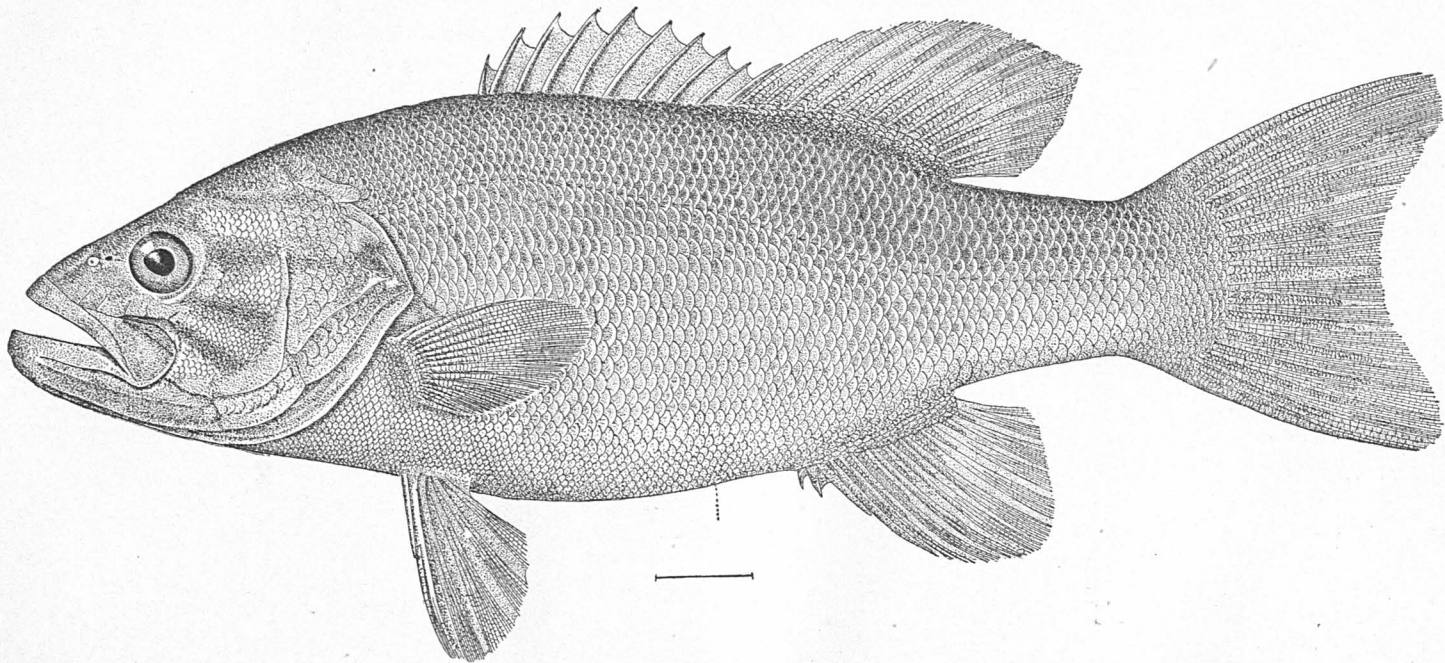

MICROPTERUS DOLOMIEU. *Small-mouth Black Bass.*

THE BLACK BASSES, CRAPPIES, AND ROCK BASS.

DESCRIPTION OF THE FISHES, COMMON NAMES, ETC.

The species treated of in this chapter are those members of the *Centrarchidae* (or fresh-water sunfishes) which have come under the scope of fish-culture, namely, the large-mouth black bass (*Micropterus salmoides*), the small-mouth black bass (*Micropterus dolomieu*), the rock bass (*Ambloplites rupestris*), the crappie (*Pomoxis annularis*), and the calico bass (*Pomoxis sparoides*). Whatever is said of the rock bass will apply equally well to other sunfishes, which might be here considered but which have not been artificially reared.

The principal physical characters of these fishes are indicated in the following key, which serves to distinguish the two species of black bass and the two species of crappie from each other as well as from less closely related species.

Large-mouth black bass: Body comparatively long, the depth about one-third the length; back little elevated; head large, 3 to 3½ in body; eye 5 to 6 in head; mouth very large, the maxillary in adults extending beyond eye, smaller in young. Ten rows of scales on the cheeks; body scales large, about 68 in the lateral line, and 7 above and 16 below the line. Dorsal fin low, deeply notched, larger than anal, with 10 spines and 12 or 13 soft rays; anal with 3 spines and 10 or 11 rays. Color above dark-green, sides greenish-silvery, belly white; young with a blackish band along sides from opercle to tail, the band breaking up and growing paler with age; caudal fin pale at base, white on edge and black between; older specimens almost uniformly dull greenish; three dark oblique stripes across opercle and cheek; dark blotch on opercle.

Small-mouth black bass: Similar in form to large-mouth bass. Mouth smaller, the maxillary terminating in front of posterior edge of eye, except in very old specimens. About 17 rows of small scales on the cheeks; body scales small, 11-74-17. Dorsal fin less deeply notched than in other species, with 10 spines and 13 to 15 rays; anal with 3 spines and 12 or 13 rays. General color dull golden-green, belly white; young with dark spots along sides tending to form irregular vertical bars, but never a lateral band; caudal fin yellowish at base, white at tip, with dark intervening area; dorsal with bronze spots and dusky edge; three radiating bronze stripes extending backward from eye; dusky spot on point of opercle.

Crappie: Body short, greatly compressed, back much elevated; depth

2½ in length; eye large, one-fourth length of head; head long, 3 in length; profile with double curve; mouth large, snout projecting. Scales on cheeks in 4 or 5 rows; scales in lateral line 36 to 48. Dorsal fin smaller than anal, with 6 spines and 15 rays, the spinous part the shorter; anal with 6 spines and 18 rays; dorsal and anal fins very high. Color silvery white or olive, with mottlings of dark green; the markings mostly on upper part of body and tending to form narrow, irregular vertical bars; dorsal and caudal fins with dark markings; anal nearly plain.

Calico bass: Similar in form to crappie, but the body shorter, back more elevated, and profile of head straighter; depth, one-half length; head one-third length; mouth smaller than in crappie; snout less projecting. Six rows of scales on cheeks, and 40 to 45 along lateral line. Dorsal and anal fins higher than in crappie; dorsal spines 7 or 8, rays 15; anal spines 6, rays 17 or 18. Color, light silvery-green, with dark-green irregular mottlings over entire body; dorsal, caudal, and anal fins with dark-olive reticulations surrounding pale areas; whole body sometimes with a delicate pink reflection (whence the name strawberry bass).

Rock bass: Body oblong, compressed, back moderately elevated; depth 2 to 2½ in length; head large, 2¾ in length; eye very large, 3½ in head. Scales 5-39-12, in 6 to 8 rows on cheeks. Dorsal fin much larger than anal, with 11 spines and 10 rays; anal, with 6 spines and 10 rays. Opercle ending in two flat points; gillrakers less than 10. Color olive-green, with brassy reflections; young irregularly barred and blotched with black; adult with a dark spot at base of each scale, forming interrupted and inconspicuous stripes; a black spot on opercle; anal, caudal, and soft dorsal fins with dark mottlings.

The most reliable character for distinguishing the large-mouth from the small-mouth bass is the number of rows of scales on the cheeks. The colors of each species vary with age and the size of the mouth varies with the size of the fish, but the scales are constant under all conditions. With the crappies, the leading differential feature is the number of dorsal spines.

By reason of their wide geographical range, the black basses have received a multiplicity of popular names. The large-mouth black bass is known as Oswego bass, lake bass, green bass, yellow bass, moss bass, bayou bass, trout, jumper, chub, and welchman. In the North it is generally called black bass; in Virginia and North Carolina it is usually designated as the chub, and in Florida and the Southern States it is often called trout. The small-mouth black bass has received the common names of lake bass, brown bass, ninny bass, hog bass, black perch (used in the mountain sections of Virginia, Tennessee, and North Carolina) trout perch, brown trout, jumper, mountain trout, together with other names of purely local use.

Rock bass are variously known as red-eye, red-eye perch, and goggle-eye, and are sometimes confounded with the warmouth (*Chanobryttus gulosus*), which bears some of the same common names.

The calico bass has received the names of strawberry bass, grass bass, bitter-head, barfish, lamplighter, goggle-eye, goggle-eye perch, speckled perch, and speckled trout. The crappie is known in its native waters as crappie, new light, campbellite, sac-a-lait, bachelor, chinquapin perch, croppie, and cropet. On account of the similarity of the calico bass and crappie, anglers and fish-culturists have frequently confounded the two, the common and local names often being used interchangeably throughout the regions to which both are native.

Possibly no common name of the black bass is more appropriate than "jumper," which is applied in certain parts of Kentucky. That both species of the black bass are jumpers is well known to every angler, but it is better understood by those who have had occasion to collect these fishes by seining. It is almost impossible to capture them with a seine rigged in the ordinary manner, especially when the fish have the vitality and activity which is usual when living in water of moderate temperature. Like other fishes, they lose in strength and activity when they inhabit warmer waters. While the black bass of the colder northern waters make a fight worthy of the salmon, they may be taken from the waters of the south with hardly a struggle. In seining for brood stock it is well to employ a seine about three times the depth of the water, as the bagging or bellying of a seine so rigged confuses the fish and deters them from jumping.

On one occasion, when collecting black bass on the Holston River, advantage was taken of their jumping habits to effect their capture. A flatboat 12 feet wide and 50 feet long was procured and in suitable places was rapidly poled broadside from one bank to the other. As it approached the further shore the bass would leap from the stream and frequently land in the boat, the gunwale of which was cut down to within 4 inches of the water. One bass was seen to clear the entire width of the boat, making a horizontal jump of 14 feet.

A marked characteristic of the rock bass is their habit of settling down in dense, compact masses, resembling a swarm of bees, which is especially true of the young in cold weather. They are exceedingly pugnacious, and sometimes seem to take the hook rather on this account than from a desire for food. They are well adapted for pond-culture, and under proper conditions will repay the culturist in a large crop of young with the expenditure of very little labor and time.

The calico bass is a fairly game fighter, and its firm, white flesh has a fine flavor when the fish is taken from cool, pure waters; but it is a very delicate fish to artificially propagate. It seems to resent captivity, and especially when taken from warm waters is exceedingly tender, quick to yield to attacks of fungus, and liable to become blind and die. Of large numbers collected and transplanted in new waters many have died within a few days after being deposited.

The spawning and breeding habits of the calico bass and the crappie are so nearly like those of the rock bass that special remarks on the subject do not appear necessary.

GROWTH AND WEIGHT.

There is a wide difference in the rate of growth, and there is no way by which the age of a black bass can be determined from its size. Some are comparatively large from the moment they are hatched, and grow much more rapidly than the smaller members of the same school. The average size of adults varies in different localities, and sometimes will be found to vary from year to year in any particular locality. The variations depend upon initial vitality, upon the scarcity or abundance of food, and upon the range and space given the fish. At the age of 5 or 6 months the young bass measure from 4 to 8 inches, according to locality and surroundings, though a certain percentage of the crop will always run large. In 1892, at Neosho station, a black bass, which was positively known to be under 18 months old, weighed on the scales 1 pound 9½ ounces.

Large-mouth bass have been known to weigh 23 pounds. They are not infrequently taken from the San Marcos River, Texas, weighing from 12 to 15 pounds, and a 6-pound or 8-pound bass in the southern tributaries of the Mississippi and in the inland lakes of Florida excites no surprise. The small-mouth bass does not grow so large, 2½ pounds probably exceeding their average size, though they occasionally reach 5 or 6 pounds. The rock-bass fry grow slowly, those 6 months old seldom averaging 2 inches in length. The adult usually weighs from ½ to ¾ pound, occasionally reaching 1 pound; and examples have been recorded as high as 3 pounds.

The crappie and the strawberry bass will, as a rule, not exceed 1 pound in weight, though in Missouri the former has been taken as high as 3 pounds. Under like conditions of pond environment, at 6 months old the young of both these species are about the size of black-bass fry of the same age, possibly a little smaller. Each school will have a few individuals much larger than the majority.

NATURAL HABITAT AND DISTRIBUTION.

The large-mouth and small-mouth black basses are widely distributed. The natural range of the large-mouth is from the Great Lakes and the Red River of the North to Florida, Texas, and Mexico, and west to the Dakotas, Nebraska, and Kansas. The small-mouth bass ranged formerly from Lake Champlain to Manitoba, and southward on both sides of the Alleghanies to South Carolina and Arkansas. The adaptability of these fish to extremes of temperature and their great tenacity of life under seemingly adverse conditions has rendered their distribution comparatively easy, and they have been successfully introduced into nearly all the sections of the United States to which they were not native, and into England, France, Germany, and Finland. They have been planted in California, Washington, Utah, and other Western States by the United States Fish Commission. In three years they became so numerous in Utah that 30,000 pounds were caught and marketed from one lake.

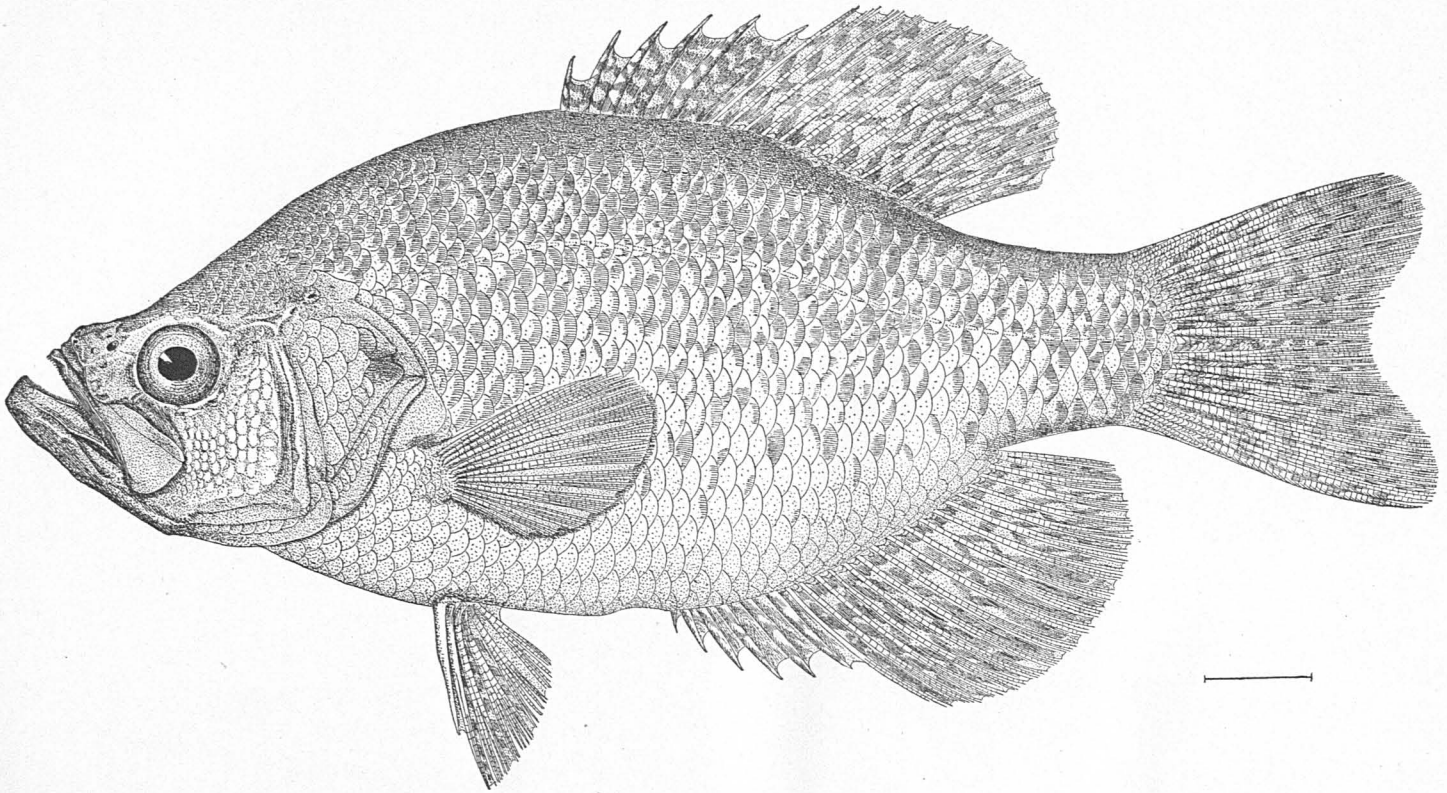

POMOXIS ANNULARIS. *Crappie.*

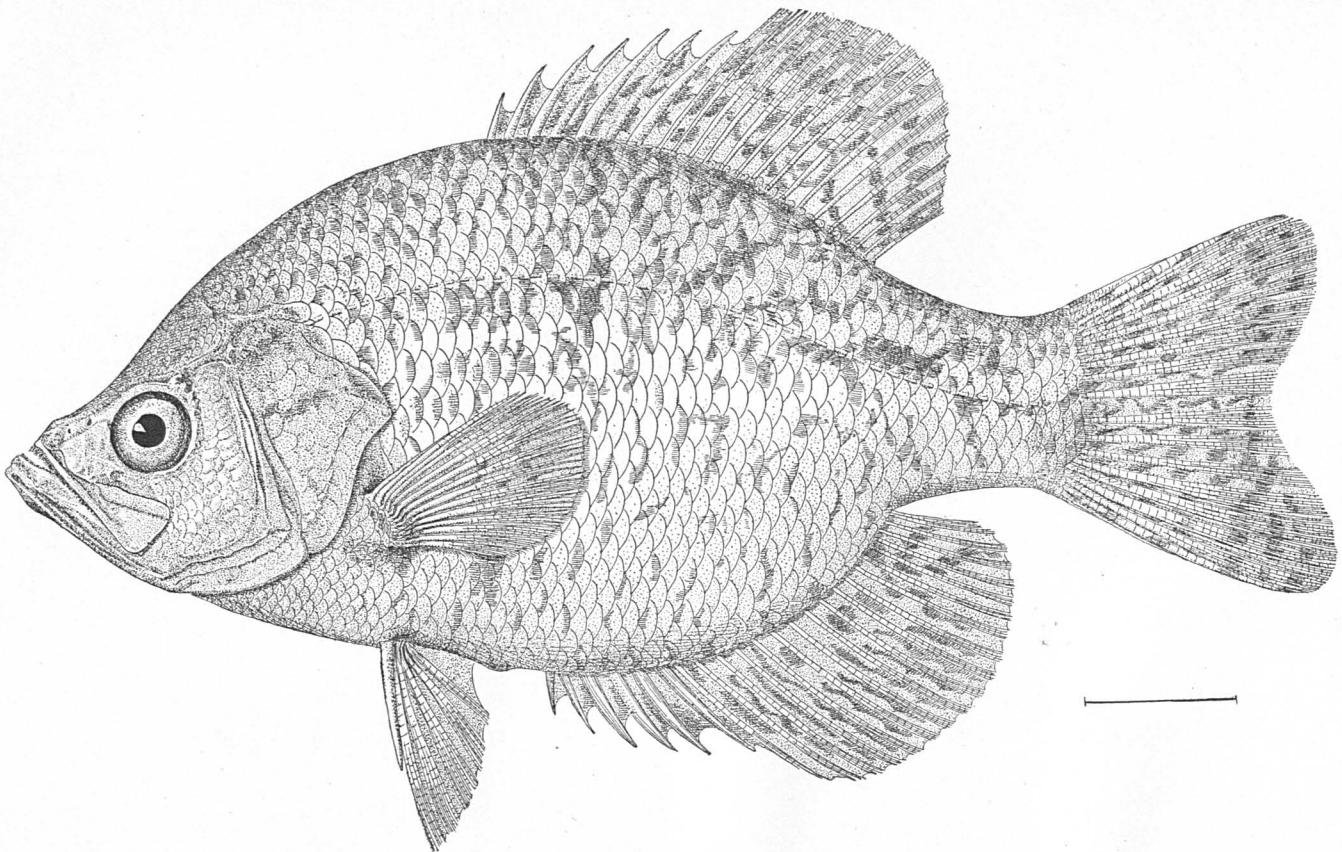

POMOXIS SPAROIDES. *Calico Bass; Strawberry Bass.*

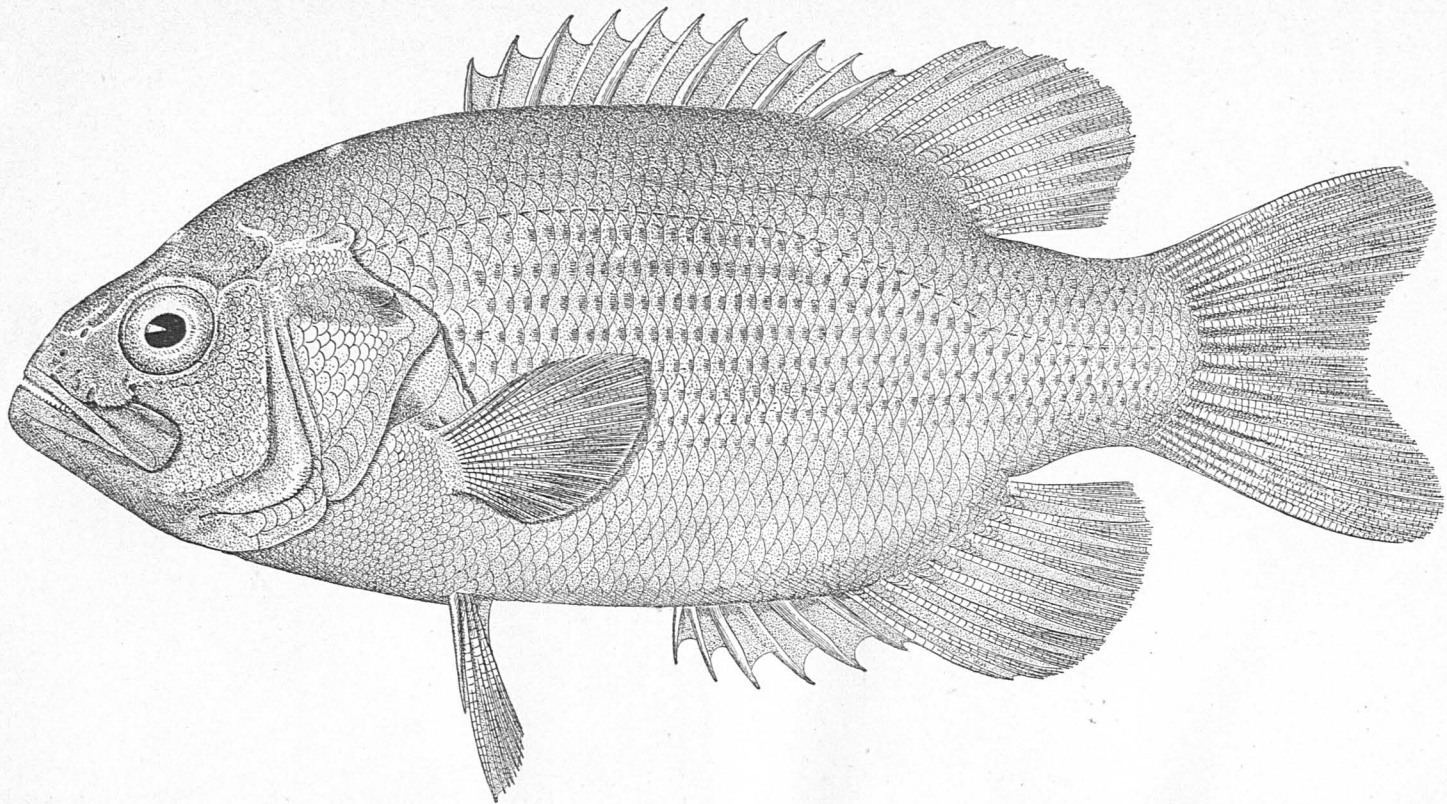

AMBLOPLITES RUPESTRIS. *Rock Bass.*

Two notable early instances of the successful transplanting of black bass in a primitive way may be mentioned, the fish being transferred in the tender of a locomotive—once in 1853, when the Potomac was stocked, and again in 1875, when, under the direction of the Commissioner of Fisheries of Virginia, adult black bass were moved from the Roanoke River across the divide to the New River, a tributary of the Kanawha. Up to 1875 the Kanawha contained no bass, and its edible fishes consisted almost entirely of catfish, but for the past ten or a dozen years thousands of bass have been taken from New River and its numerous tributaries, draining ten counties of Virginia and running through parts of North Carolina and West Virginia. New River was also successfully stocked with rock bass by the Virginia Fish Commission, the fish being brought from Holston River, a tributary of the Tennessee in Washington County, Virginia, in June, 1876, and deposited in the smaller tributaries of New River, in Montgomery County, Virginia, whence they have colonized the entire New River basin.

Few fish thrive in water of such varying extremes of temperature as the large-mouth black bass, and, to a certain extent, the small-mouth. The former are found in water covered with ice and in that standing at 100° F.; but with both species sudden changes of temperature frequently prove fatal.

The small-mouth black bass seeks pure, rapid, fairly clear streams, and lives at higher elevations and in clearer waters than the large-mouth. In the northern part of its range it becomes torpid in winter, but in the warmer waters of the South it is active throughout the year. The large-mouth black bass also likes pure, clear water, but often inhabits the hot and stagnant bayous and ponds of the South. It has been seen in great numbers under conditions of high temperature and muddy water which would ordinarily be fatal to all forms of aquatic life except of a very low order. Many die under these conditions, but numbers live for months and some possibly for years. Those from hot, stagnant waters, however, have a soft, flabby flesh, and are apt to be infested with parasites; they spoil quickly and are not palatable. Bass do not voluntarily seek such unfavorable surroundings, and their presence there is attributable to accident. The bass found in the Mississippi valley under these conditions have been left by the spring freshets, and, failing to go out with the slowly receding waters, they reproduce in great numbers in the ponds and lakes temporarily formed in the depressions of the land. The surroundings are generally either rich alluvial meadows or swampy forests, from which the receding water drains an infinite quantity of natural food for the sustenance of the fish retained in the temporary ponds.

The rock bass is indigenous to the Great Lakes region and Mississippi Valley, and there is evidence to show that it is native to certain streams on the east side of the Alleghanies. It has been successfully introduced into many new waters. In its native waters it is found in the winter months under ice, and stands a high summer temperature,

though not so great as the black bass. The highest temperature to which it has been subjected at Neosho is 88°. The transportation of this species would indicate that it suffers from change of temperature as quickly as the black bass, with possibly this difference, that while the black bass seems to be more quickly and fatally affected by a change from high to low temperature, the opposite change more quickly and injuriously affects the rock bass. Though sometimes found in muddy bayous and in waters of the middle South stained by decaying vegetation, the rock bass thrives better in clear, pure waters well stocked with aquatic plants.

The natural habitat of the calico bass is the Great Lakes region, the entire Mississippi Valley south to Louisiana, and the streams of the Carolinas and Georgia east of the Alleghanies, while its close kin, the crappie, is confined to the Mississippi Valley, though it is sometimes taken in the Great Lakes region. The calico bass is said to demand a higher temperature and clearer water than the crappie, but this is not certain.

NATURAL FOOD, ETC.

The natural food of the black basses varies greatly, and is influenced by the spawning season, character and temperature of the water, and the weather. They are voracious and pugnacious, and devour other fish almost indiscriminately. The food of the adults comprises crayfish, minnows, frogs, tadpoles, worms, and mussels, and the young feed on insects and other minute forms of life found in water.

At times both the large-mouth and small-mouth bass refuse the most tempting bait, and at other times they bite greedily at almost everything. Various kinds of animals of a suitable size, even rats and snakes, and many varieties of vegetables, have been found in their stomachs, and in a wild state under some conditions they devour almost anything moving in or immediately over the surface of the water.

The black basses afford perhaps the highest type among fishes of parental care and watchfulness, guarding their young until after the dispersal of the school of fry; but a large part of the young, so zealously protected early in the season, at a later date furnish food for adult bass, possibly their own progenitors. As with trout, bass of the same school of young vary in size, and the larger prey mercilessly upon the weaker, often attacking their own kind when other natural food is abundant.

COMMERCIAL IMPORTANCE.

The market value to the fishermen of the black bass taken in the United States amounts to about \$130,000 annually, a sum representing over 2,000,000 pounds of fish. A great part of the bass caught, however, never reach the market, being consumed by anglers and their friends. The indirect value of bass fishing to rural districts, in the expenditures of visiting sportsmen for boats, guides, teams, supplies, and accommodations, is very great.

Ten years ago it was said that black bass did not exist in sufficiently large numbers to ever become a staple article of food, but they now furnish important additions to the food supply of many thousands of people. The annual sales in New York are estimated to be at least 50,000 pounds, with an average value of 10 cents per pound. Possibly because of the abundance of whitefish and lake trout, Chicago does not seem to afford as good a market for bass as other large cities. A recent estimate places the sales of all the bass handled by wholesale dealers of Chicago at 15,000 pounds, but these figures are probably too low. The Illinois fishermen ship nearly 50 tons of black bass to the markets annually, and it is a reasonable assumption that Chicago consumes a very large part of the production of the surrounding country.

The States in which the black-bass fishery is most important are North Carolina and Ohio; in 1890, over 400,000 pounds, valued at \$20,500, were caught for market in North Carolina; in Ohio, in 1894, nearly 300,000 pounds, worth over \$22,000, were taken. Other States in which there is an annual yield of over 100,000 pounds are Arkansas, Florida, Minnesota, Missouri, and New York, and in about twenty other States this fish is of some commercial importance.

The annual catch of crappie for market, according to recent statistics of the United States Fish Commission, is about 850,000 pounds, having a first value of \$39,000. The leading States in this fishery are Arkansas, Illinois, Minnesota, Missouri, and Tennessee, the three first named producing more than half the yearly yield. The market value of the rock bass is not large. Crappies are generally considered better food-fish than the rock bass and enter much more largely into commerce. As with black bass, a very large percentage of the catch of crappies, rock bass, and sunfishes does not reach the markets.

LIMITATIONS OF BASS-CULTURE.

The artificial propagation of black bass, by taking and impregnating the eggs, has not been, up to the present time, practically successful. Unlike the shad and salmon, eggs can only be stripped from the female with great difficulty, and it has been necessary to kill the male to obtain the milt. Another obstacle is the difficulty of finding the two sexes ready to yield the eggs and milt at the same time, even when they are taken from over the nests apparently in the act of spawning. Interruption or handling seems to prevent the discharge of eggs or milt. At Neosho unsuccessful efforts were made daily for several weeks to spawn a female black bass in which a part, at least, of the ovaries were fully developed. The fish was so near the point of spawning that when held head downward the eggs could be seen to roll forward toward the head, and when reversed to drop in the opposite direction.

Since a way to artificially impregnate the eggs of the bass has not yet been discovered, and the handling of eggs with indoor apparatus is impossible, it is fortunate that the natural impregnation of these fishes reaches a percentage closely approximating that which fish-culturists

have been able to secure by artificial means from other species, and also that the parental instinct is unusually developed. The first conditions make pond-culture necessary and the second render it possible. The methods hereafter described are those in use at Neosho station.

ARTIFICIAL PONDS FOR REARING BASS.

The size of spawning-ponds is controlled, to a certain extent, by circumstances. Small ponds which are long and narrow, with the inlet

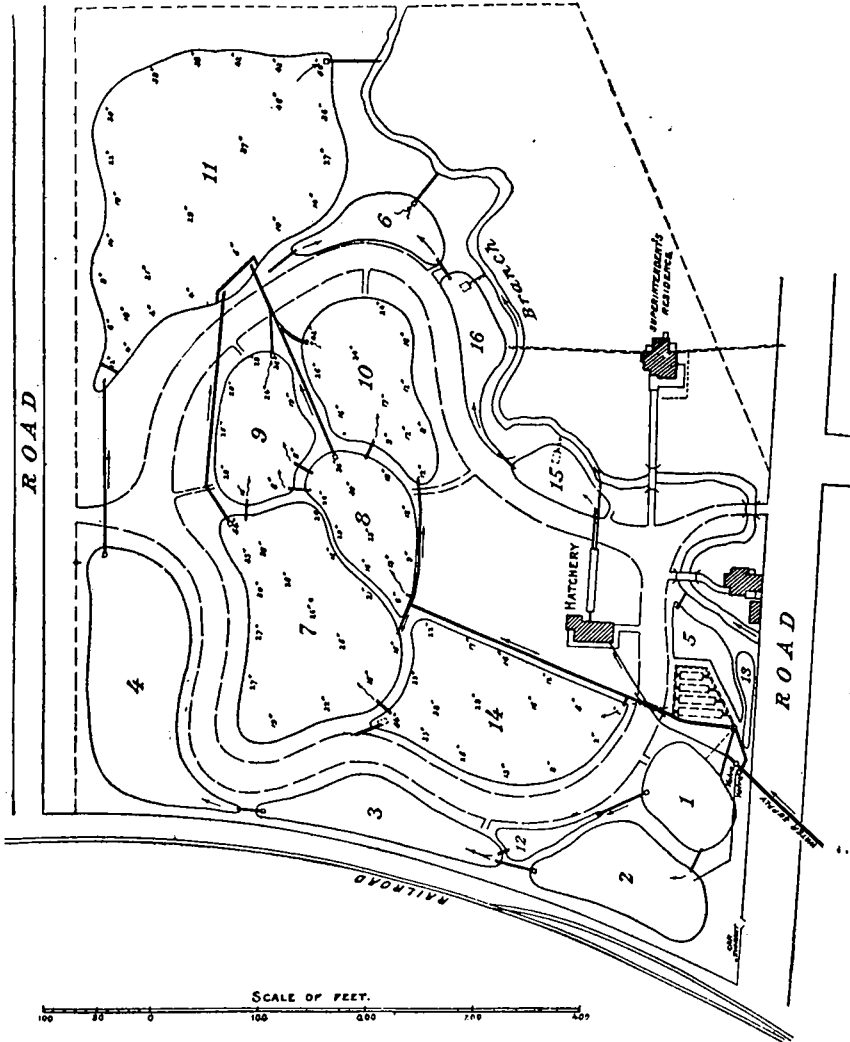

Plan of Neosho Station, showing shape and depth of ponds, with location of hatchery and superintendent's dwelling.

at one end and the outlet at the other in the line of the longest axis, produce the best results, as the strength of the current can be better controlled, and the whole pond regulated under the scrutiny of attend-

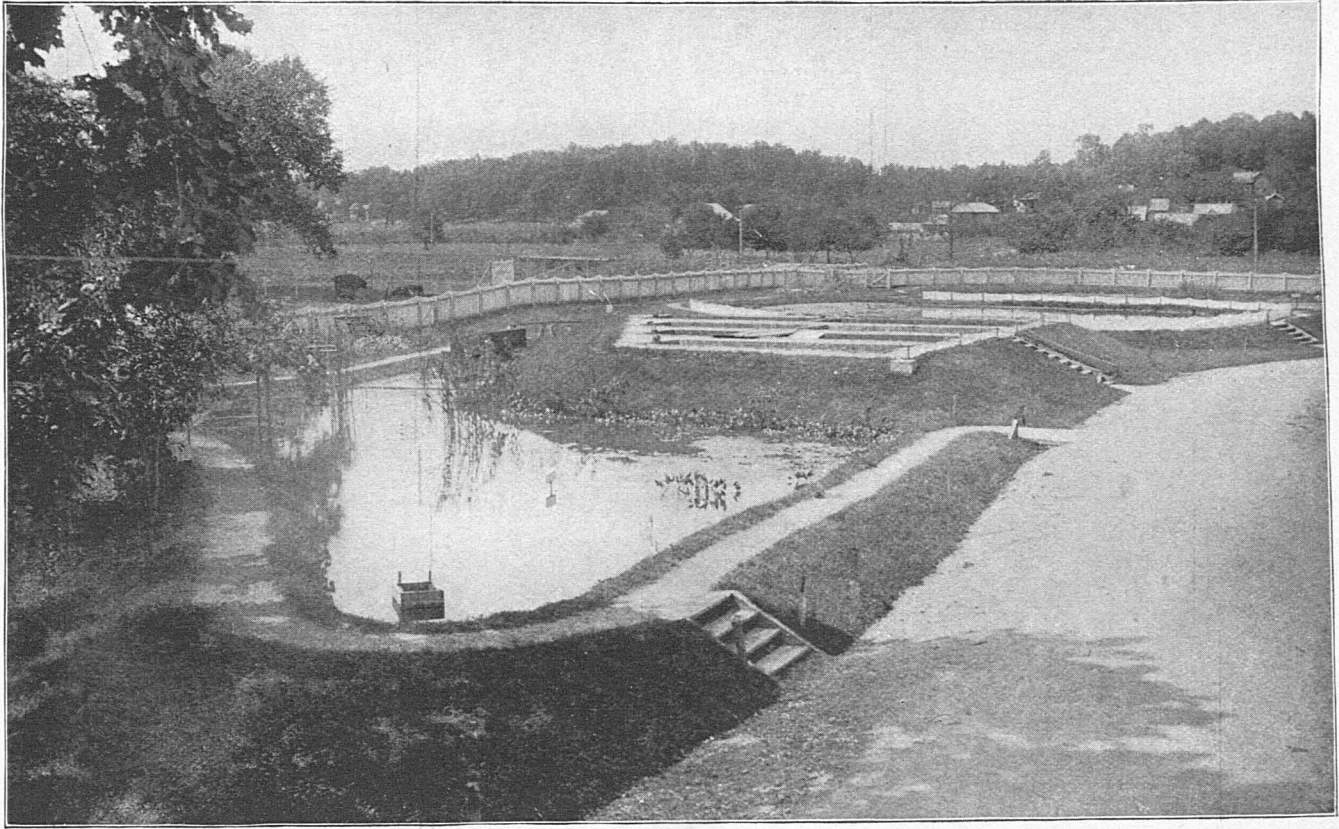

BASS AND TROUT PONDS AT NEOSHO, MISSOURI.

ants from the shores. Large ponds furnish wider range, and this is desirable when fish are raised for market, but large spawning or nursery ponds are not recommended; and if the object is to produce large quantities of young for distribution in new waters small ponds are undoubtedly better.

At least one-fourth of the pond should be not over 1 foot in depth, and this portion should be planted with pond-weed (*Potamogeton*) and water-weed (*Elodea* or *Anacharis*) to facilitate the production and growth of the minute animals, which furnish so large a part of the food for the young bass. The remainder of the pond should have a gradually sloping bottom, and consequent increase of depth to the kettle (or draw-off), where the water must be at least from 3 to 6 feet deep for the warm Southern States, and 12 to 14 feet deep for the Northern States, to provide against the danger of freezing. In the middle third of the pond water-lilies should be planted, preferably those having the largest pads, such as the *Nymphaea alba*; these plants not only furnish the breeding fish a hiding-place from fish-hawks, but serve as sunshades during the summer. It is not usually advisable to place large boulders in the ponds, as they are in the way of seining or netting, and furnish an acceptable resort for crayfish.

When the young, under the guidance of the parent fishes, are schooling, they may be collected from the nests and deposited in waters to be stocked, or transferred to nursery-ponds. These ponds should be constructed to afford young bass protection from enemies and to produce the greatest quantity of insect life suited to their sustenance, and this is better accomplished with a number of small ponds than with one large one. A good working size is from 40 to 50 feet long by 12 to 15 feet wide, with a depth of from 30 to 36 inches for the "kettle."

Where the topography of the ground will permit, it is best to have the nurseries immediately adjoining the spawning-pond, with the water supply from the same source, so that there will be but slight difference between the temperature of the shallowest part of the nursery-pond and the surface water of the other. As in all other ponds for fish propagation, the supply and discharge for each nursery-pond should be independent of any other, and the bottoms be made to slope toward the "kettle." The young large-mouth bass is not a strong fish, and currents in the spawning and nursery ponds should be avoided for some time after the spawning period.

If the locality is infested with crawfish, it is advisable to pile or otherwise protect the banks; and the entrance of snakes, frogs, and such enemies may be prevented by surrounding the pond with finely woven screens, or, better yet, boards let into the earth a few inches and projecting above the ground. The pond should be supplied with the aquatic plants previously mentioned as desirable for the shallow parts of the spawning-pond.

A plan has been suggested, which combines the features of a spawning and nursery pond, by constructing one comparatively long pond,

narrow near the middle, so that the general shape will be like a dumb-bell with a very short handle. Across the narrow part is to be stretched a screen of $\frac{1}{4}$ -inch wire cloth, which will confine the spawners to the deeper end of the pond, while the fry, following their instinct of moving upstream, will find their way through the screen into the upper, shallower end. This method would apparently not only save much labor in transferring the fry, but obviate the risk involved in handling them.

If it is desired to hold the bass until they attain their full growth, the fry are transferred to troughs or pools where they are reared in a purely artificial manner—that is, tamed and trained to take prepared food. For this purpose modifications in the shape and arrangement of the spawning-pond are necessary, somewhat as described above for the combination pond. The shallow part near the inlet has a long, narrow neck and the general shape, where the ground permits, follows the outline of a gourd. That part which resembles the handle is screened off from the remainder with wire netting, with a quarter-inch or less mesh. The young fry, after the dispersal of the school, seek the shallow waters, which, warmed by the sun, at this time of year afford rich pasture of *Cyclops*, *Daphnia*, young *Corixa*, and other small invertebrates. Following the natural inclination of young fishes to head toward the source of the water supply, they pass through the screen and collect within the neck of the pond, where the food supply will be found to be greater than around the margin. From this part of the pond the fry have no inclination to retreat, and the parent fish can not follow and devour them.

TROUGHS.

The ordinary horizontal trough in general use in trout-culture is well adapted to raising young bass fry. A trough 12 to 14 feet long with 4 inches depth of water at 57°, changing 2 gallons per minute, will support from 3,000 to 5,000 black-bass fry, and twice or three times as many rock bass will live comfortably under like conditions. For bass of larger size, fingerlings and upward, vats or pools answer better than troughs. The troughs can be so arranged that the water discharged from them furnishes the supply for one or more pools. The shape, size, and number of the pools must be regulated by the topography of the land, though they should not be wider than 6 feet, nor with a depth of water greater than 2 feet, and either lined with plank or built of brick or stone. Wire netting or guard-boards, projecting 1 to 1½ feet above the ground, prevent the entrance of snakes and other enemies. As with all ponds, provision is made to entirely empty one pool without interfering with the water supply of another, and to have a good fall from inlet to outlet. The length of the pool must be regulated by the lay of the land, and, if long, it is advantageous to divide the pool into sections, with movable screens of wire cloth for convenience in handling several sizes of fish.

The same general care and cleaning usually given to troughs containing trout fry is necessary in cultivating bass. The trough is swept down twice a day and occasionally washed inside with a cloth, and the water supply, conduits, and outlets frequently examined and kept clear and clean.

The young bass is able to stand any temperature to which the sun raises the water of the nursery; those hatched in water at 56° F. will thrive two months later with the temperature at 86°. However, bass grown in very high temperature are exceedingly tender, and can not be handled and transported until the approach of fall and winter has gradually reduced the temperature and so hardened them. Moreover, under such conditions they are more liable to attacks of parasites, both external and internal. While bass can live in water ranging from 33° to 98°, more moderate limits are desirable. The *Cyclops* and some other of the natural forms of food for young bass reproduce best at a temperature between 68° and 70°, and can not resist higher than 95°.

CARE OF PONDS.

It is desirable that the ponds should be "wintered" each year—that is, entirely drawn off in the autumn, thus leaving the beds exposed to the combined action of sun, winds, and frost. This tends to kill out the larvæ of the larger aquatic insects (dragon-flies, beetles, etc.), and to increase the following season's supply of small crustacea, which furnish an important element of food to the young bass. This purifying process can be assisted by the free use of quicklime dropped into the crayfish holes. There is no danger of the lime injuring the fish the following year, as lime-water is more beneficial than harmful, and the process purifies the pond-bed, besides killing the crayfish and the like.

In addition to the yearly wintering, the accumulated decayed matter ought to be occasionally removed, the frequency for this depending on the character of the water supply, the amount of silt it brings into the pond, the character of the soil, and on the thoroughness of the yearly removal of the surplus mosses. Scraping large ponds and hauling the accumulated muck involve considerable labor and expense, possibly more than the yield of the pond warrants, and in some cases it is advisable, once in four or five years, to lay the pond bare for an entire year and cultivate it in peas or some other deep-rooted vegetable.

While abundant pond vegetation is favorable to a large production of fry, it is sometimes so luxuriant that it settles down in a blanket-like mass and smothers many of the young fish. Under such circumstances it should be removed some time in advance of lowering the pond level, and during the process should be carefully picked over, as some of the fry will be found among it. Wading into the pond leaves the bottom tracked with deep footprints, which, as the water recedes, catch and retain many of the young fishes, most of which die in a short time. To avoid this a strong but lightly built flatboat is used, which can easily be moved from pond to pond as needed. At either end of

the boat is a ring through which a stake is driven at the point in the pond to be worked. The vegetation is raked from the water in small lots, and unloaded on the banks with a pitchfork. It should be promptly removed from the bank, as it will rot very fast and its presence is objectionable.

NESTS AND NEST-BUILDING.

Whenever the spawning period occurs, whether early or late, ample warning is given by the preparation of the nests, which are built by the mated fish, sometimes working in company and sometimes separately. The nests are ordinarily built in gravel, brushed into neat circular piles 18 inches to 3 feet in diameter, and are usually found in water from 18 inches to 3 feet deep, though not infrequently in much deeper water and sometimes in water less than a foot in depth.

In the proper preparation of the newly built spawning-pond clean gravel, ranging in size from a buckshot to a hickory nut, is arranged in small flat heaps about 4 to 6 feet from the banks as soon as the ice is off in the spring, in advance of the spawning season, and, if well located, it can be used through several seasons and more than once in the same season. Gravel probably possesses no advantage, of itself, over a hard clay bed except that it presents more surface within a given area for the eggs to attach themselves to; but if gravel of suitable size is to be had the bass usually select it, and no matter how dirty it may be, or how overgrown with moss and algæ, they clean it with the caudal fin and tail until it is as bright as if every particle had been polished with a brush, often using the head and mouth to remove the larger stones from the nest. On the Mississippi River and in Texas, however, black bass have been observed to deposit their eggs on mud.

Some bass build several nests in a season and are compelled to remove a comparatively large quantity of rough and jagged material, yet very few wounded or abraded bass are captured. At Neosho the same bass have been observed at nest-building for seven years without showing a torn or worn caudal or anal fin. Trout, on the contrary, wear their caudal fins and tails to the very bone in their efforts, and often die in consequence. Many of the wounds on the trout at spawning time are due as much to fighting as to the wear and tear of nest-building; and the bass also are hard fighters.

The proximity of the nests to each other depends on the size of the pond and the number of fish. They are sometimes less than 5 feet apart, and in a spawning-pond of the Michigan Fish Commission, having only 108 square feet of surface and containing 30 adult fish, there were 8 nests. If the nests are placed near the banks, in water from 18 inches to 3 feet deep, the entire process of spawning and incubation is easily observed and the fry can be more conveniently secured and transferred to nursery-ponds at the proper time. The larger fish are apt to select deeper water, but they have been known to decline a clean lot of gravel, in water 3 feet deep and 8 feet away from the

embankment of the pond, to build a nest on the naked clay bottom within reach of the bank on which people were passing almost every hour. Nesting bass should have seclusion, although those reared in captivity probably fail to notice minor disturbances at the time of spawning which would at other times alarm them.

Artificial nests for bass have been devised, which should give increased results in the number of fry saved by simplifying the transfer of fry to nursery ponds and eliminating the risk of handling with nets. The artificial nest is a wooden box about 20 inches square, with sides $2\frac{1}{2}$ inches high and slightly flaring outward. Cleats are nailed

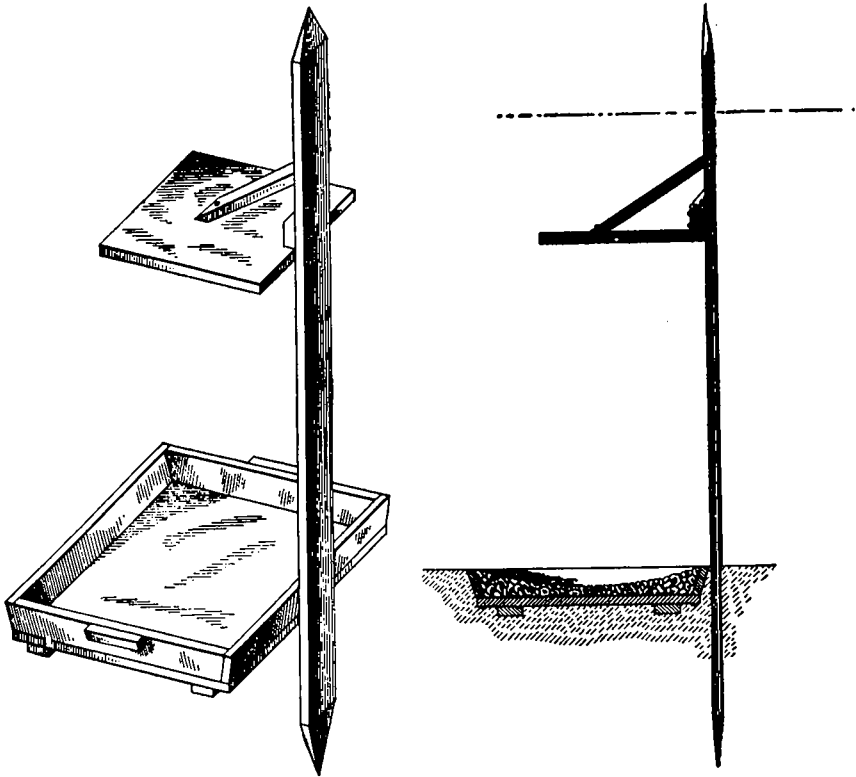

Artificial Nest for rearing Black Bass (perspective and sectional views).

on the side for convenience in handling. Coarse gravel is placed in the bottom of the box and the remaining space filled with fine gravel, flush with the top of the box. The top layer is sufficiently fine not to allow the eggs to fall through the spaces and mix with the large gravel underneath. The nest, thus completed, is placed in an excavation with the upper edge even with the bottom of the pond. A stake is driven near the nest and a board fastened to it to afford seclusion and protection from the sun and enemies. A round pottery nest, about the same size, with a rim sufficiently high to retain the gravel, is also used. Shade is

important, for, although bass sometimes build nests where there is no shade, in most instances they select places under overhanging grasses, lily-pads, stumps, and logs. The artificial nests should be located several weeks in advance of the expected spawning, and undue disturbance of the pond should be avoided. They must be examined often, and all containing young fish removed to the rearing-ponds.

From the time the bass commence nest-building the attendant keeps the pond and its contents under constant surveillance and maintains a close watch for fish-hawks and herons. A record is kept, as nearly as practicable, of the date when each lot of eggs is laid, so that it may be known when to expect the young to hatch. If artificial nests are used, the observations can be made more carefully, and numbers can be painted on the shade-board to designate the particular nests, and the records of hatching and spawning can be kept with greater accuracy.

STOCKING THE BREEDING-PONDS.

Whenever procurable, domesticated fish are to be preferred to wild fish for this purpose, as they are less liable to injury in handling and transportation. A disrupted scale, lacerated fin, or a bruise on head or body frequently causes the death of wild bass, and the conditions of their native surroundings make it difficult to collect any considerable number of them. Moreover, adult fish captured from their native waters frequently fail to spawn in the year or season in which captured, on account of fright.

Bass not over 2 or 2½ pounds are recommended if the work is carried on in ponds which are to be frequently drawn off, but larger fish can be used advantageously if they are to be but rarely transferred to other ponds. Very large bass are more liable to injury when the ponds are drawn and the fish transferred, as they are more difficult to handle safely, and bruise and injure themselves in the tubs. Males and females should be in equal proportion, as an excess of males is liable to prove a disturbing element at spawning time, and, later in the season, a source of loss from their preying on the fry. The sexes of the black bass are not as easily distinguishable as of the trout. The number of adult fish for breeding-ponds depends upon the food supply. For several years past at Neosho an average of 30 breeding bass to the acre of water has been allowed, but that number might be increased.

SPAWNING HABITS.

When the nests are prepared and the spawning time arrives, the parent fish—especially the male—show considerable excitement and swim back and forth over and around the nest. In the act of spawning they cross the nest, their bellies close together, the male a little behind the female, and simultaneously void the eggs and eject the milt, the real act of spawning occupying a comparatively short time—a minute or less. The eggs, when laid, are viscid, and as soon as voided

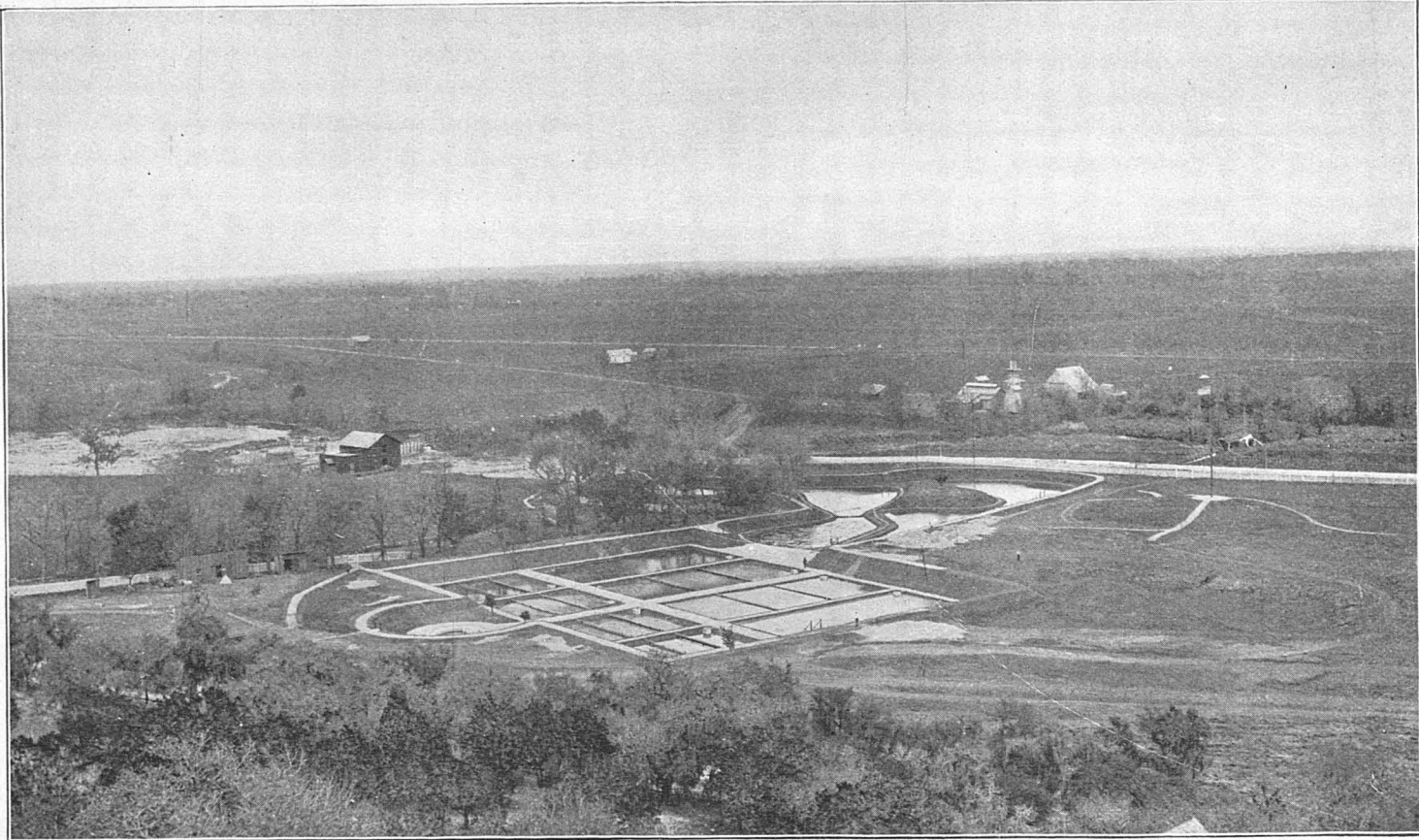

BASS PONDS AT SAN MARCOS, TEXAS.

and impregnated attach themselves to the floor of the nest. Then commences a parental watchfulness worthy of imitation on the part of some higher animals, one fish hovering immediately over the nest and maintaining a gentle motion of the fins for the purpose of keeping the eggs free from sediment, and the other acting as an outer sentinel, patrolling 8 or 10 feet away. Both male and female show great courage when guarding their eggs and young fry. A rock bass has been seen to leap entirely out of the water to bite viciously at an attendant's hand when moving aside the grasses sheltering the nest, and a black bass when guarding its nest has been known to attack and kill a snake three times its own length. The brightness of the nest makes the parent on guard easily distinguishable by enemies, like the fish-hawk and eagle, but this danger may be materially lessened by planting the broader-leaf water-lilies near the nests to afford shelter when in danger.

Black bass begin to spawn in the northern part of the United States about the middle of May, while farther south the season commences as early as March, and in all localities it is later in deep than in shallow waters. In the far South, in waters uniformly warm, the spawning time may not depend entirely on the seasons. The period lasts about two months. Many, if not all, discharge only a part of their eggs at one spawning. The maturation of the entire ovaries is never fully completed at one time, but the ripening is prolonged and the spawning done at intervals. As far north as southern Missouri and Illinois, black bass frequently spawn in the season following the spring when they are hatched, but this is not always the case; and farther north maturity comes later in life. Bass continue to yield eggs for a number of years, and there are some in the brood ponds at Neosho which were adults when first taken to the station, and have been held for seven years and are still productive, though less so than formerly.

Rock bass have been known to produce two separate broods within one season as far north as southern Missouri, and this is probably true of some of the other basses. At Neosho they spawn when one year old.

EGGS AND FRY.

The eggs differ greatly in number and size, according to the age and size of the fish, varying generally from 2,000 to 10,000 per fish and from 80,000 to 100,000 per quart; 17,000 eggs have been found in a large-mouth black bass weighing 2½ pounds, a little less than 7,000 to the pound of fish; but on another occasion careful count of the mature eggs showed only 2,674 to the pound of fish. Wide discrepancies in the figures may be sometimes accounted for by different methods of counting, as in rejecting or counting small eggs which are commencing their maturation for the next production. The rock-bass egg is fully three times as large as that of the black bass, and the fry correspondingly large.

The varying factor of initial vitality and the impossibility of equalizing the intensity of sunlight render it impossible to determine pre-

cisely the period of incubation of any eggs treated in pond-culture. With some kinds, under extreme conditions of temperature and other less understood factors, wide variations are found. Bass eggs require from 7 days to 3 weeks for hatching, but usually from 8 to 10 days—governed mostly by the temperature of the water. Eggs artificially impregnated, in an experimental way, hatch in from 70 hours to 4 days at a temperature of 63° F., or somewhat over.

When the fry leave the eggs, they remain on the nest till the sac is absorbed, this depending, as with other fishes, on the period of incubation, modified by the temperature or condition of the atmosphere; usually a fifth less time being required to absorb the sac than for hatching the eggs. When the sac is absorbed, the fry rise from the nest and form a school which hovers over the nest usually from two to four days, settling back at night, except in extremely warm weather, when they may scatter in a few hours. A sudden fall of temperature may cause the school to settle back and remain a day or two longer on the nest. The tactics of the parents change and they no longer stand guard over the nest, but circle around the school, whipping back truants and driving off intruders. When the school rises and hunger begins to be felt, the fry separate and are driven, for protection, by the parent fish into shoal water or into the thick grasses; there they are deserted, and dispersing, they seek the minute crustacea, larvæ, and insects.

Black-bass fry do not average one-fourth of an inch in length and are almost colorless for the first three to five days, when the pigment forms along the back, making them appear quite dark when viewed from above, though it is difficult to distinguish the color of an individual fish when caught on a net of bolting-cloth.

Very young rock bass seem occasionally to attach themselves to the sides and bottom of the nests and to submerged plants. This action has not been noticed with black bass, possibly because their nests, being in deeper water, are more difficult of observation.

FOOD OF THE YOUNG.

Just how much food to give the young bass fry is as difficult to determine as with any other young fish. They are very greedy, and, if acceptable food is given them, appear to be hungry nearly all the time, and it is more than probable that the troubles caused by overfeeding other fishes would show themselves in the bass if they were overfed. Bass, like the trout, are given about 1½ per cent of their weight in food per day. This ratio will maintain black-bass fry in a healthy growing state, and probably less will be found to answer with rock-bass fry. Compared with other fishes reared in troughs, especially some of the trout, bass are easily managed. Healthy fry have been carried at Neosho for four months with a loss of only 2 per cent. When first brought into the troughs, they can not be induced to take the prepared food, as they are wild and must be tamed or domesticated. They are

fed almost every hour in the day, though but little food is given at one time and that well scattered through the trough. The attendant should be about the trough constantly to accustom them to his presence, care being taken not to alarm them. Instead of being frightened and darting to the dark corners of the trough at his approach, they soon learn to come to meet him, not a few at a time, but all together.

For several days their food will have to consist of such minute animals as can be conveniently collected from the ponds with a dip net of cheese-cloth. After four or five days they will accept prepared food, as fish of some kind, ground to a fine paste. In general, bass fry under $1\frac{1}{2}$ or $1\frac{1}{2}$ inches in length are too small to take artificial food, and some die before they can be accustomed to take it.

The number of young bass to be put into a pond depends upon its size and its capacity to produce food. If the nursery has been prepared in advance with aquatic plants some crustacea will be found there, and the deficiency is supplied by the introduction of snails, *Gammarus*, *Corixa*, etc. The use of beef liver as food is not advised. To a nursery in fair condition from 3,000 to 5,000 young bass may be allotted. The death of a part of these must be expected, and if even a fair percentage are to survive they must have more food than the pond can grow. Should a large part of them survive the first few weeks they can be distributed into other nurseries.

At Neosho crayfish have been used for food with good results, not that they have any value over other forms of aquatic life, but because they are abundant, cost nothing, and are acceptable to the fish. Young bass can easily be fed on any kind of fish, and all that is necessary is to reduce the fish to a paste by passing it through a meat-cutting machine. Carp may be cultivated for the purpose. At the Forest ponds of the Missouri Fish Commission little branch chub are caught and placed in the pond several weeks before the bass spawn. As the chub spawn and hatch out before the bass, when the young bass are transferred to the nursery they find a lot of young chub ready to be eaten. An objection is that the old chubs destroy the young bass, though this could be obviated by hatching the chub artificially (as can be easily done) and turning only the young chub into the pond. However, the propensity to cannibalism in the bass should not be fostered, and it is better not to feed bass, old or young, on any kind of live fish. They are thus trained, while under domestication, to forego their natural inclination for fish diet.

Sometimes, even with abundance of natural food, the young prey upon each other, and they should then be thinned out by transferring a part to nursery-ponds, or the entire lot removed to troughs or vats in the hope of inducing them to take the prepared or natural food. As the summer advances the strongest fish may be observed to grow rapidly, and at the first evidence of unusual growth the fish must be sorted out and those of a certain size placed in separate ponds. The successful

raising of bass in ponds depends very largely on frequent and careful sorting, and a fish that persists in efforts to devour his companions should be either liberated or destroyed.

TRANSFER OF FRY FROM HATCHING-PONDS.

In transferring the fry to troughs or other ponds two nets of cheese-cloth are required. The main one is about 30 inches square, supported by ribs from above; to the center of the ribs a handle is attached, so that the net can be used 5 or 6 feet from the shore; the net is made to sag to an open pocket in the center, which can be closed and tied with a drawstring. The second net is easily made from an ordinary landing-net by replacing the netting with cheese-cloth. This will be useful in catching the fry that escape from the larger net. The transfer is made in tubs filled with water from the spawning-pond in order to preserve the same temperature as nearly as possible. Netting is done in the early morning, as the shallow waters of the pond become cool during the night and the temperatures of the different waters are more nearly equal.

The process of netting requires patience and a degree of skill which comes with practice. The operator stands on the bank and introduces the net with a gentle and scarcely perceptible side movement under the school and cautiously lifts it out, and, when the net is clear of the water, turns with a quick motion and brings it over the tub, so that the part of the net holding water and fish can be readily submerged in the tub. An assistant stands near the tub to catch the sides of the net and help in the latter part of the operation. While the operator holds the rod to which the frame of the net is attached, the assistant slips his hands into the tub and unties the drawstring of the net pocket, and the net is then gently lifted out of the tub. A bucket of water from the pond, and a dipper, are kept at hand to wash any of the fry into the tub that may stick to the cheese-cloth. The fry should never be freed from the net by the use of a feather or by shaking.

As soon as the collected fry are in the vessels they are carried to the troughs or pools, when the temperature of the water in the bucket or cans is compared with that flowing through the troughs. An experienced workman can tell by the sense of touch whether there is a material difference in the temperature, and can take the steps toward equalizing it. Should there be a difference of 3° or more, it must be corrected. If a vessel is not crowded, an effective, though slow, method of equalizing the temperature is to set or suspend the vessel in the water flowing through the pool or trough. If the water in the vessel is warm and the time short, in addition to setting the vessel in the trough, a part of the water may be bailed from the vessel and replaced with fresh colder water. This operation is known among fish-culturists as "tempering;" it requires care, good judgment, and patience.

It is well to have several large buckets made with "windows," that is, a small screen of perforated metal in one side of the bucket near the

top. The windowed bucket is put in a trough under a small jet of water, conducted by a rubber tube to the bottom of the bucket. The jet discharging at the bottom of the bucket, and the surplus water escaping through the perforated window, assist in the process of tempering. The temperature being equalized, the fish are carefully ladled into troughs or pools and the various sizes sorted and separated into different troughs.

A part of the fry do not find their way through the wire screens into the cut-off, and all around the margin of the pond, even in the deep water, straggling fry may be seen. Sometimes these scattered youngsters will be small, but generally they are the largest. After all the fry have been captured from the cut-off and the season's spawning is over, the pond is drawn to collect and save those that have failed to come into the cut-off. This work is generally in June or July, when the ponds are quite warm and the temperature of the atmosphere is high, and is carried out with extreme watchfulness and care, as the midsummer drawing of a bass pond is the most delicate operation connected with their propagation in ponds. These fry need to be "tempered" and sorted in the same way as advised for other fry.

During the various stages of its life the bass is subject to the attack of enemies of many kinds. The fish-eating birds, like the kingfisher; wading birds, like the heron, and amphibious animals, like the mink and muskrat, must be guarded against. Snakes, frogs, turtles, and various beetles are dangerous to the fry, and sometimes even to adult fish.

SHIPPING FRY.

Collecting for shipment occurs in the cool days of autumn, as experience has shown that the bass can be much better and more safely transported in the spring and fall than in the summer. They can be transported more cheaply in midwinter than any other time, but when fish are moved long distances in very cold weather (or at any other time when much ice is used in the cans) many die from gill troubles. After the ponds are freed from vegetation and are ready for drawing off, the water level is reduced slowly. Every precaution is taken not to frighten the fish, and with this in view no more attendants are allowed about the bank than are absolutely necessary. Black bass when frightened will burrow in the mud and live there an incredible length of time, and if a fingerling burrow in the mud when the pond is being drawn he may prove a dangerous occupant the following spring when the young fry are introduced. The same precautions should be observed in transferring fingerlings as with the very young fry.

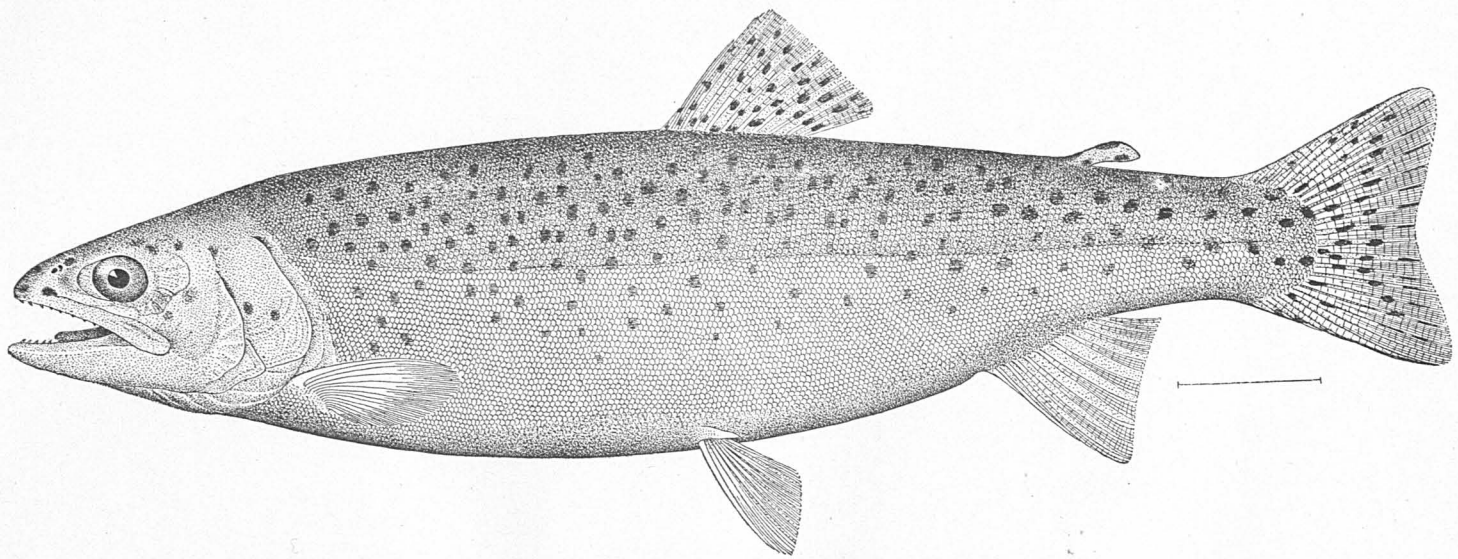

SALMO MYKISS. *Black-spotted Trout.*

MISCELLANEOUS FRESH-WATER FISHES.

Besides the fresh-water and anadromous fishes considered in the foregoing chapters, a number of others have been artificially cultivated, including some species introduced from Europe. The special methods of propagation already referred to are in general applicable to all fishes of similar character, and need not be described again in detail.

MINOR TROUTS AND THE GRAYLING.

The different methods of hatching the eggs of the various members of the salmon family are practically interchangeable, so that in considering the following species it is not necessary to dwell again on fish-cultural processes.

Several varieties of the black-spotted trout (*Salmo mykiss*) are artificially propagated. This fish is somewhat similar to the European sea trout or salmon trout (*Salmo trutta*) and in parts of its range has the same half-migratory habits. It is widely distributed, very abundant, and subject to great variation in color and structure. It is found from Alaska to Mexico in the streams of the Coast Range, Sierra Nevada, and Rocky Mountains, and in some lakes in the same regions. It attains a weight of over 30 pounds, although the average is, of course, much less.

Among the varieties whose eggs have been artificially hatched are the Lake Tahoe trout or Truckee trout (*Salmo mykiss henshawi*), which is extensively propagated by the California Fish Commission at hatcheries on Lake Tahoe; the Colorado River trout (*Salmo mykiss pleuriticus*), and the yellow-fin trout (*Salmo mykiss macdonaldi*), both of which are cultivated by the U. S. Fish Commission at its station at Leadville, Colorado. All of these species are handsome game and food fishes.

In the vicinity of Leadville the spawning season extends from May 1 to July 15. The eggs are hatched in the same troughs and under the same conditions as those of the brook and rainbow trouts. In water ranging from 42° to 60° and averaging about 52° F., the eye-spots appear in 20 days and hatching ensues in 30 to 45 days.

The Scotch lake trout, or Loch Leven trout (*Salmo trutta levenensis*), and the European brown trout or brook trout, or Von Behr trout (*Salmo furio*), were introduced by the Fish Commission a number of years ago, and have been widely distributed in the United States. They are now propagated in many States from eggs taken from brood fish retained in ponds. At Northville the spawning season of these fish is the same

as that of the brook trout. Their eggs are somewhat larger than those of the latter fish, but they are handled in the same way, the progress of incubation is similar, and the fry are fed on the same materials.

Small numbers of the European sea trout or salmon trout (*Salmo trutta*) have also been propagated at Craig Brook and other stations, and have been reared to full maturity in ponds.

The fish called the Swiss lake trout, European charr, or saibling (*Salvelinus alpinus*), has been propagated on a small scale from eggs taken from pond fish, which in turn were hatched from eggs sent from Switzerland. This species is similar to the brook trout and other native charrs, and its eggs are subjected to the same methods.

The representative of the saibling found in certain New England lakes, known as the Sunapee trout, or golden trout (*Salvelinus alpinus aureolus*), has also received some attention from fish-culturists.

The Michigan grayling (*Thymallus ontariensis*) is naturally found only in certain streams in Michigan, although the type specimen was said to have come from Lake Ontario. It is one of the most attractive and game of fresh-water fishes, but is rapidly approaching extinction, owing to excessive fishing and the pollution of streams, which have not been counteracted by artificial propagation. The Montana grayling (*Thymallus ontariensis montanus*) inhabits a limited area in the head-waters of the Missouri River and is very abundant in some streams.

The Arctic grayling (*Thymallus signifer*) is found from the Mackenzie River westward through Alaska and north to the Arctic Ocean. The Michigan grayling rarely weighs 1½ pounds, and the average weight is only half a pound; the northern species is somewhat larger.

Although the cultivation of the grayling was begun as early as 1874, it was never regularly or extensively conducted. Spawning in Michigan occurs in April, and the eggs are normally laid in gravel beds in clear, cold streams. The number of eggs taken from a single fish varies from 3,000 to 4,000. The same methods of culture pursued with the brook trout are applicable to the grayling. In water having a temperature of 50° to 60° F., the incubation period is 14 to 20 days.

THE LAKE HERRING AND OTHER WHITEFISHES.

While the common whitefish is the only member of the tribe that has received much attention from fish-culturists, it is probable that several other species of whitefish will in time be extensively propagated. The lake herring (*Argyrosomus artedi*) has already been artificially hatched to a limited extent at Put-in Bay station, and the long-jaw or bloater (*Argyrosomus prognathus*), the bluefin or blackfin (*A. nigripinnis*), the tullibee (*A. tullibee*), and others will doubtless become the subjects of fish-cultural work in certain lakes. The eggs of all these fish can be hatched by the same methods as are used with the common whitefish, but the spawning seasons differ.

The lake herring is readily distinguished from the common whitefish by its smaller size, projecting lower jaw, long and numerous gillrakers,

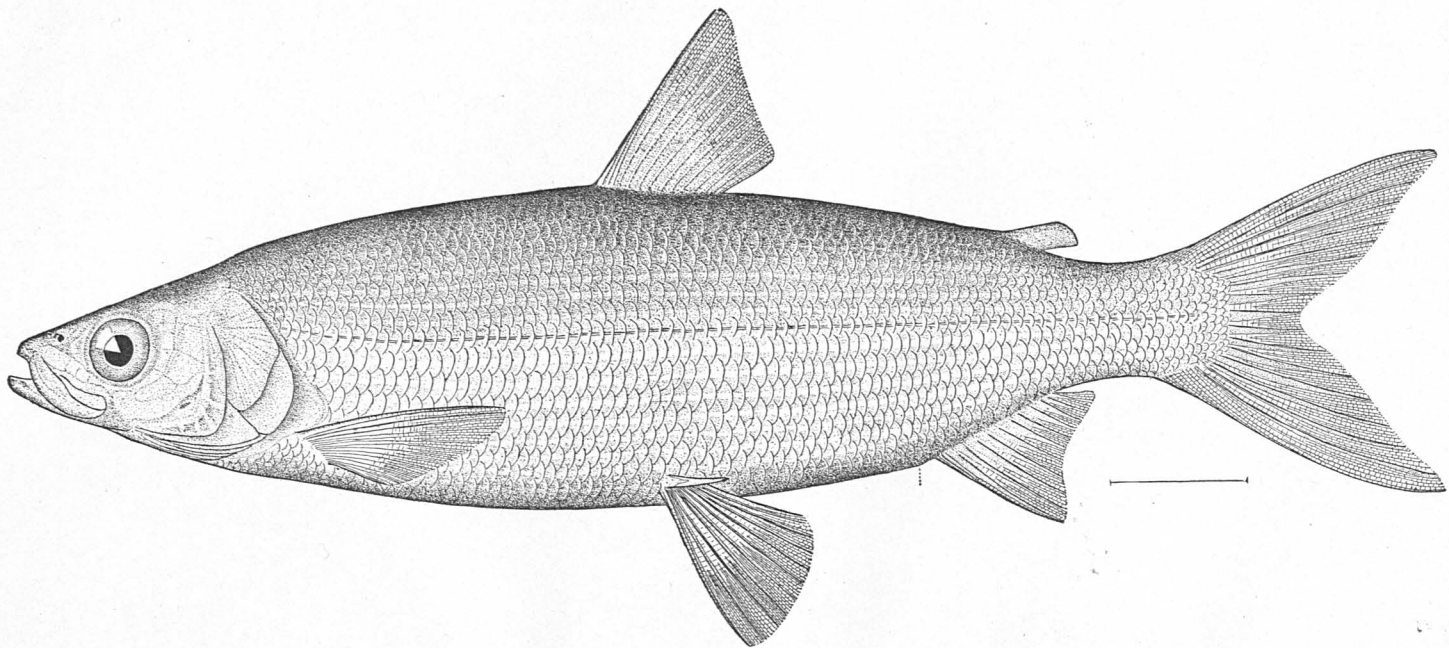

ARGVROSOMUS ARTEDI. *Lake Herring; Cisco.*

absence of arch on back, etc. It is the most abundant of the whitefishes, being especially numerous in lakes Erie, Michigan, and Huron, and larger quantities are taken each year than of all other species combined. The average length is 12 to 14 inches and the average weight is under a pound, although a maximum weight of 3 or 4 pounds is attained. The fish is generally known as "herring" but has numerous other names, among which are cisco, blueback herring, greenback herring, grayback herring, and Michigan herring.

The spawning season of the lake herring begins somewhat later and terminates sooner than that of the whitefish. The eggs are procured and hatched in the same manner as are those of *C. clupeiformis*, and require about the same time for incubation, namely, 4 to 5 months, depending on the temperature of the water. The eggs are smaller than those of the common whitefish, 70,000 making a fluid quart.

These two species are readily hybridized artificially. The milt of either species will impregnate the eggs of the other as effectively as if there were no cross fertilization. Large specimens of apparently hybrid fish of this character have been obtained in Lake Erie. The use of milt of the lake herring for impregnating whitefish eggs is resorted to only when the eggs would otherwise be lost.

The round whitefish or menominee (*Coregonus quadrilateralis*) is propagated by the New York Fish Commission. It is very widely distributed, ranging from New Brunswick to Alaska, and is abundant in some of the Adirondack lakes, where its eggs are taken and hatched in comparatively large numbers. It rarely exceeds a pound in weight, but its food qualities are good, and it is taken for market in considerable quantities in lakes Huron and Michigan.

In the New York lakes, where the fish is known as the frostfish, the spawning season is from the middle of November to the early part of January, although the period in any one lake is less prolonged. The eggs are heavy, adhesive, and $\frac{1}{8}$ inch in diameter; the average yield per fish is 3,500, but 12,000 have been taken from a $1\frac{1}{2}$ -pound fish. In the very cold water of these lakes the incubation is protracted, being 150 days with the water at 33° F. The sac is absorbed in 10 to 20 days.

THE MUSKELLUNGE.

The muskellunge (*Lucius masquinongy*) is the largest representative of the pike family. Its maximum weight is about 80 pounds and its average weight 25 or 30 pounds. Its range includes the Great Lakes, Upper Mississippi Valley, Ohio Valley, and lakes in Wisconsin, Minnesota, New York, Ontario, and elsewhere. It is much sought by anglers and is of some value as a food fish. Being provided with a very large mouth, armed with strong, formidable teeth, its food consists chiefly of living fish, which it captures by making sudden darts from its place of concealment among the water-plants at the bottom of a lake or stream.

This fish is artificially propagated by the New York Fish Commission at Chautauqua Lake. Upward of 3,000,000 fry are sometimes hatched

in a year. The eggs are taken from fish caught in the lake, and are hatched in submerged boxes, provided with double wire-mesh tops and bottoms. The eggs are similar to whitefish eggs, being semibuoyant and nonadhesive. A 39½-pound fish has been known to have ovaries weighing 5 pounds, and a 35-pound fish has yielded 265,000 ripe eggs. Spawning takes place in May, in shallow, grassy places. The eggs are about $\frac{1}{11}$ of an inch in diameter and number 74,000 to the quart. About 97 per cent of the eggs impregnated are hatched. With the water temperature at 55° F., hatching ensues in 15 days, the yolk-sac being absorbed in the same time. The fry are very helpless when first hatched.

Owing to the extremely voracious habits of the muskellunge, great caution should be exercised in distributing the fry, which should, as a general practice, be placed only in those waters in which the fish already exists.

THE YELLOW PERCH.

The yellow perch (*Perca flavescens*), known also as ring perch, striped perch, and raccoon perch, is one of the most strikingly marked and best known fresh-water fishes of the Atlantic and North-central States. It is commonly regarded as the type of the spiny-rayed fishes and in some systems of classification is given the first place among fishes.

The general body color is golden yellow, the back being greenish and the belly pale; six or eight broad vertical blackish bars extend from the back nearly to the median line of abdomen; the lower fins are largely bright red or orange, most highly colored in the breeding male; the dorsal fins are dull greenish. The body is elongated, back arched, mouth large and provided with bands of teeth on jaws, vomer, and palate.

It is found from Nova Scotia to North Carolina in coastwise waters, throughout the Great Lakes, and in the Upper Mississippi Valley, and in most parts of its range is very abundant. Through the efforts of the Commission it has been very successfully introduced into lakes in California, Washington, and other Western States, and is now met with regularly in the markets of some of the cities of that region.

The usual length of the yellow perch is less than 10 inches, and its average weight is under a pound. It is a food-fish of fair quality, and is taken for market in very large quantities annually in the Middle States and Great Lakes, fyke nets, gill nets, seines, traps, and lines being used. The value of the output is over \$300,000 yearly, more than a third of which sum represents the fishery in the Great Lakes. It bites readily at the baited hook and is caught in large quantities by anglers.

Artificial propagation, in the full sense of the term, has not been attempted with the yellow perch. The eggs have neither been artificially taken nor artificially impregnated, but the brood fish have been impounded and their naturally fertilized eggs hatched. The extent to which this modified cultivation of yellow perch may be carried on in the coast rivers, in the Great Lakes, and elsewhere is almost limitless.

The fish is so abundant, however, and the supply so well maintained that fish-cultural work in its behalf is not now generally required.

This fish spawns in late winter and early spring in the fresh waters of the coast rivers and in the Great Lakes. In the Potomac River spawning takes place in February, March, and April. The water temperature at which spawning begins is about 44° F., while 49° seems to mark the maximum limit. This narrow range of temperature which bounds the spawning act is somewhat noteworthy.

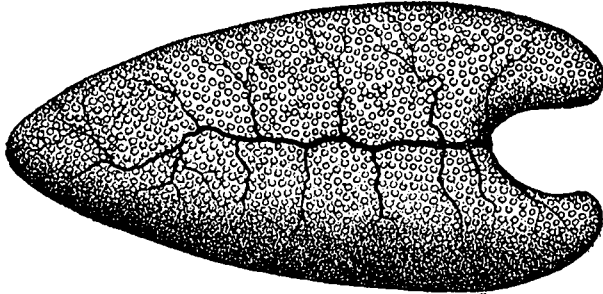

Ovary of a yellow perch with nearly-ripe eggs, the forked extremity being the anterior part of the roe.

The eggs of the yellow perch are among the most remarkable that have been artificially hatched. The spawn is in one piece, a much elongated ribbon-like structure, of a semitransparent light-grayish color. One end of the large egg mass, corresponding to the anterior part of the roe, is larger than the other, and is bluntly forked. The string is very long,

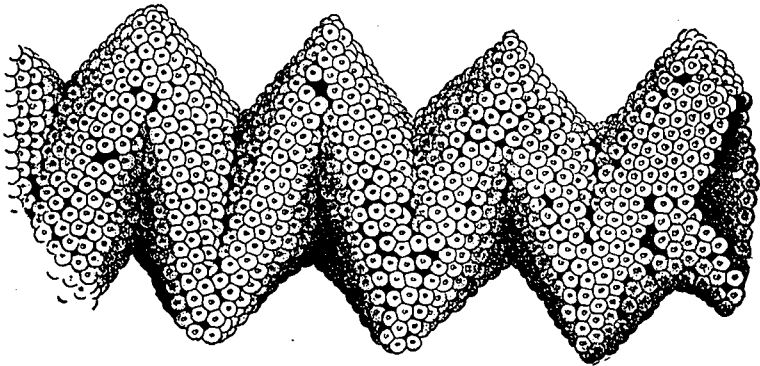

Part of a recently-laid mass of yellow-perch eggs.

but may be much compressed lengthwise by virtue of its arrangement in regular transverse folds like the sides of a bellows or accordeon. When deposited the eggs are in a loose globular form, and after being fertilized and becoming "water-hard" their mass rapidly becomes many times larger than the fish which laid them. The length of the strings is from 2 to more than 7 feet, depending on the size of the fish. One

fish in an aquarium at Washington deposited a string of eggs 88 inches long, 4 inches wide at one end and 2 at the other, whose weight after fertilization was 41 ounces avoirdupois, while the weight of the fish before the escape of the eggs was only 24 ounces.

A cavity extends the whole length of the egg mass, its walls being formed by the delicate membrane in which the eggs are imbedded. The cavity is almost closed, small apertures occurring irregularly, which have the appearance of being accidental, but may be natural, in order to permit the circulation of water on the inside of the mass.

The egg-string is quite light and resilient or springy, the least agitation of the water causing a quivering motion of the whole mass.

The diameter of the egg is $\frac{1}{3}$ inch. The quantity can not be easily measured, but the number is approximately 28,000 to a quart.

The best method of securing the spawn is to place mature fish of both sexes in suitable tanks with running water. The females selected should be those whose external appearance indicates that the eggs are still undeposited. Spawning takes place at night, and the eggs are naturally fertilized. Under proper conditions, it is the exception to find unfertilized eggs. In the morning the eggs are transferred to the hatching apparatus.

The eggs of this fish have been hatched at different stations of the Commission. One season, at Central Station, Washington, D. C., 130 ripening females and about an equal number of males taken from the Potomac were placed in aquarium tanks supplied with water from the city water-works. Spawning began March 10 and continued till April 3, and 98 strings, containing nearly 1,000,000 eggs, were deposited.

The eggs are hatched in the automatic shad jar, provided with a cap of fine-meshed wire netting; the usual inflow tube is retained, but the siphon tube is withdrawn, the water escaping over the top of the jar. The amount of water circulation is not great enough to force the mass of eggs to the upper part of the jar or to give much motion to them. They are lighter than shad or whitefish eggs, and when put in rapid motion to dislodge adhering sediment they would clog the outlet tube if the ordinary method of manipulating this jar were employed.

The eggs from several fish may be placed in one jar. They perhaps need as little care as any eggs handled by fish-culturists. When one string of eggs or one lobe of a string dies it may be removed with a small net, or the entire contents of the jar may be turned into a pan.

The period of hatching varies from two to four weeks, according to the temperature. As the fry hatch, they pass over into tanks provided with screened overflows, where they are held till planted. The fry are very hardy, and may be readily retained in aquaria for several weeks. The percentage of eggs hatched is large. From one lot of 955,000, 754,000 fry, or 79 per cent, were produced.

THE STRIPED BASS AND THE WHITE PERCH.

The striped bass, or rockfish (*Roccus lineatus*), ranges from New Brunswick to western Florida. It is especially abundant from New York to North Carolina, and is taken in large quantities for market, by means of seines, gill nets, pound nets, and lines, on the coast and in the bays, sounds, and rivers. It is one of the best food-fishes of American waters. The annual value of the catch is about \$300,000.

Through the efforts of the Commission, this fish has been introduced into the waters of California, where it has become very abundant; it occurs along almost the entire coast of that State, but is most numerous in San Francisco Bay and tributaries. It supports a special fishery, and the estimated catch in 1897 was about 1,000,000 pounds. It meets with ready sale, and is one of the most popular fishes of the west coast.

The striped bass attains a weight of over 100 pounds; examples weighing 50 to 75 pounds are not uncommon; but the usual size of those taken for market is 3 to 20 pounds. Its form, size, and markings make it readily distinguishable from other fishes. The color of the body is light silvery-green above, white below, with seven or eight blackish stripes along the sides.

The striped bass passes most of its time in salt water, but in spring ascends the rivers to spawn. Important spawning-grounds are the tributaries of Albemarle Sound, Chesapeake Bay, Delaware Bay, and New York Bay. The eggs are sometimes deposited quite near the ocean, in brackish or salt water. The number that may be deposited by a single fish is immense; a fish weighing only 12 pounds, caught at the mouth of the Susquehanna River, in May, 1897, yielded 1,280,000 good eggs, and a 75-pound fish would doubtless produce 10,000,000 eggs.

The commercial importance of the striped bass and its comparative scarcity in some waters in which it formerly abounded make its cultivation very desirable, and its eggs have been artificially impregnated and hatched on several occasions; but difficulty has been experienced in finding a locality where ripe eggs can be regularly taken in large quantities. The eggs are free, transparent, and semi-buoyant, about $\frac{1}{7}$ of an inch in diameter, and have a very large oil-globule. In quiet water they gradually sink to the bottom of a vessel and remain there, but a very slight agitation of the water causes them to rise and remain in suspension for some time. The number in a quart is about 24,000.

The tidal apparatus, such as is used for cod and tautog eggs, is adapted to hatching the eggs of this fish. At a mean temperature of 58° F., the hatching period is about 74 hours. A large oil-globule in the anterior part of the yolk-sac causes the younger fry to assume a perpendicular position, with the head toward the surface of the water.

The white perch (*Morone americana*) belongs to the same family as the striped bass, and closely resembles it in range, habits, and character of the eggs; but it is much smaller and less valuable commercially,

although one of the choicest of pan fishes. Its eggs are deposited about the same time and in the same places as those of striped bass and are susceptible of the same methods of hatching. Ripe fish are frequently taken in shad seines. The average yield of eggs per fish is about 40,000. The period of incubation is like that of the striped bass.

THE ALEWIVES OR RIVER HERRINGS.

The alewives or river herrings have the appearance of being small-sized shad, but on close inspection will be seen to have characters which entitle them to generic distinction. From the shad (*Alosa*) they differ chiefly in having the cheeks longer than deep, fewer and shorter gill-rakers, and no notch at the tip of the upper jaw. They also closely resemble the common sea herring (*Clupea*), but may be distinguished from it by the absence of teeth on the vomer, by a less elongate body, and by much stronger scutes or plates along the ventral edge of the body. The two species of alewives so closely resemble each other that they are often confounded by fishermen.

The branch herring (*Pomolobus pseudoharengus*), also known as the branch alewife, gaspereau, wall-eyed herring, etc., has a rather deep and compressed body (the depth being contained $3\frac{1}{2}$ times in length), a large eye, and a pale or gray membrane (peritoneum) lining the abdominal cavity. The glut herring (*Pomolobus astivalis*), also called blueback, sawbelly, kyack, summer herring, etc., has a more elongate body, smaller eye, lower fins, and a dark or black peritoneum.

The alewives are the most abundant food-fishes of the east coast rivers and rank next to the shad in commercial value among the anadromous fishes of the Eastern States. Both species range along the entire Atlantic coast of the United States, but the glut herring is more numerous southward and the branch herring is the principal fish in New England. The average weight of each species is one-third to two-fifths of a pound. The maximum is only half a pound. The age at maturity is three or four years.

There is an alewife fishery in every coast State from Maine to Florida, but two-thirds of the catch is taken in Maryland, Virginia, and North Carolina, Chesapeake Bay and Albemarle Sound being the chief centers of abundance. The total output in 1896 was 62,066,622 pounds, having a value of \$459,598. These fish usually go in large schools or bodies, which are often of immense size. Many hundred thousand have frequently been taken at a single seine haul, and they have at times been so abundant in North Carolina and elsewhere as to crowd out shad and other fish and cause a suspension of shad fishing.

Besides furnishing food for man, in a fresh, pickled, and smoked condition, alewives are consumed in large quantities by other food-fishes, especially in salt water, and are extensively utilized as bait in the important line fisheries of New England.

The annual migration of the alewives from the ocean to the fresh-

water rivers is wholly for the purpose of spawning. The time of their arrival in a given place is quite constant from year to year. The branch alewife precedes the summer alewife by three or four weeks, and also arrives several weeks before the shad. The run of the glut herring occurs during the middle of the shad season. The branch herring ascends the small streams to spawn, often entering branches only 10 feet wide and not more than 6 inches deep. After spawning, very little is known of the habits of the fish or of the departure from the rivers; nor has their winter abode been ascertained.

The eggs resemble those of the sea herring rather than of the shad, being glutinous and adhering to brush, stones, piling, and other objects under water. The netting, ropes, and stakes of traps in which the fish are caught are often covered with the fertilized eggs; the alewives thus have a great advantage over the shad, and to this fact must largely be attributed the continuance of the supply in the face of very extensive fishing not counteracted by artificial propagation. The eggs are about $\frac{1}{20}$ inch in diameter.

There has been no effort to regularly hatch the eggs of alewives artificially. The undiminished abundance of these fish in the regions of the most extensive fisheries has made their artificial propagation unnecessary. In the New England States, where the alewife is an important fish in many of the smaller towns, the supply has been maintained by constructing fishways which permit the fish to reach their spawning-grounds. In this way comparatively small streams have annually yielded very large quantities of fish, and many streams, in which the alewife run had been entirely inhibited by obstructions, have been reopened and very successfully restocked.

As early as 1871 the eggs of the alewife were artificially fertilized and hatched, and those of the branch herring were similarly treated in 1877. Their cultivation presents no special difficulties, and can be prosecuted on a large scale whenever it becomes necessary. The milt is first taken in a pan, and then, while one person keeps the pan in motion, another expresses the eggs; this prevents the eggs from matting together and facilitates the contact of all with the milt. Eggs adhering to the side of the pan may be removed with a stream of water.

The automatic shad jar is the proper apparatus in which to hatch the eggs, which are treated precisely like those of the shad. Sufficient water is supplied to keep them moving freely and to overcome adhesion.

The alewives are much more prolific than either the shad or the sea herring. On one occasion, in the Potomac River, 644 female branch herring yielded 66,206,000 eggs, an average of 102,800 per fish. Probably 100,000 may be taken as a fair average. The eggs hatch quite quickly under normal conditions. The period of incubation, in water having a mean temperature of 60° F., is 6 days. The fry are very minute. They are planted at the same time and in the same manner as shad fry. Those in the rivers and lakes attain a length of 2 to 3 inches by the time they move toward salt water in the fall.

THE SMELT.

This fish (*Osmerus mordax*) is propagated by the New York Fish Commission at its station at Cold Spring Harbor, Long Island. As a food-fish, it is held in high esteem, the flesh being delicate and of excellent flavor. Its range is from Maine to Virginia, on the United States coast. It is of economic importance in all the States between New York and Maine, but is taken for market in largest quantities in Maine. The average length of those sold is 6 to 9 inches, and their weight from 2 to 4 ounces. The fish enters the fresh-water rivers in fall and winter for the purpose of spawning and feeding and is then caught with lines and nets. The annual catch is about 1,700,000 pounds, valued at \$125,000.

The smelt spawns in spring, in either fresh or brackish water of rivers or brooks. The eggs, which are adhesive, are attached to stones, weeds, sticks, or other objects.

The results of smelt propagation on Long Island have been quite marked; not only has there been a large increase in the catch, but the fish have appeared in streams where they were previously unknown. The return of mature fish apparently artificially hatched has permitted the taking of many more eggs than was at first possible. In a stream previously destitute of smelts, in which fry were planted in 1885, nearly 32,000,000 eggs were collected in 1894.

The eggs are 0.05 inch in diameter and number 496,000 to the fluid quart. Smelt weighing only 2 ounces yield from 46,000 to 50,000 eggs. Some fish only 3 or 4 inches long are full of spawn.

The fish-cultural work with this species is similar to that with the yellow perch and flatfish. The spawning fish, of both sexes, are placed in troughs, which are covered to exclude light. The eggs are naturally laid and fertilized, and become attached to each other and to the troughs. They are scooped up with a flat shovel, placed on wire trays in water, and are forced through the meshes of the trays to separate them, the operation being repeated if they are not sufficiently separated at first. They are then transferred to automatic shad jars, blanketed to exclude light, which is very injurious to them. If during hatching the eggs form into bunches, they are removed from the jars and again passed through the meshes of the wire trays.

THE GOLDEN IDE.

This fish, known as the golden ide or orfe (*Idus idus*), has been introduced into the United States from Europe by this Commission. Although a food-fish of fair quality, it is seldom eaten in this country, but is chiefly used for ornamental purposes. Its usual length is about a foot and its weight 1 pound. It is a very showy fish, being of a uniform reddish-golden or silvery color. The small, weak mouth restricts the character of the natural food to vegetable and diminutive animal substances.

The fish is reared in ponds, like carp, tench, and other similar species. The ponds should be 3 or 4 feet deep, with either spring or running

water, and must have a very abundant growth of myriophyllum or other water plants. In the latitude of Washington, D. C., spawning takes place in April. The fish makes no nest, but deposits its eggs on water-plants, gravel, stones, and other substances. The eggs being adhesive, like those of most cyprinoid fishes, become attached as soon as ejected, and so remain until hatched. The eggs are about $\frac{1}{16}$ inch in diameter. They are extremely tender, and it is important that at the time of spawning the water be of an even temperature.

Under favorable conditions the eggs develop rapidly, and at a mean temperature of 56° F. hatch in 5 or 6 days. In suitable ponds, with plenty of shade and a healthy growth of plants, the natural food that the fry will secure renders artificial feeding unnecessary for a month or more. After the fifth or sixth week the young may be given small quantities of cooked corn-meal mixed with flour. They take finely divided fish flesh, bivalves, and crayfish, but the main dependence should be on the corn-meal flour mixture.

At the end of six months the young have attained a length of 3 inches, and in a year are 6 inches long. Maturity is attained at an age of 3 years.

THE STURGEONS.

There are six species of sturgeon in the waters of the United States. The common and the short-nose sturgeons (*Acipenser sturio* and *A. brevirostris*) are found only on the Atlantic Coast, ascending rivers to spawn. The white sturgeon and green sturgeon (*A. transmontanus* and *A. medirostris*) inhabit only the waters of the Pacific Coast. The lake sturgeon or rock sturgeon (*A. rubicundus*) exists in the Great Lakes, the Upper Mississippi Valley, and other northern interior waters. The shovel-nose sturgeon or white sturgeon (*Scaphirhynchus platyrhynchus*) is found in the Mississippi and other streams of the Southern and Western States.

While all of the sturgeons are edible and caught for market, the most valuable species are the common sturgeon and the lake sturgeon, which alone have been artificially propagated.

The catching of sturgeon for market is a business of comparatively recent origin. A few years ago enormous numbers were annually killed and thrown away by salmon, shad, and whitefish fishermen, to whom they were of no value. The special apparatus employed in taking sturgeon consists of gill nets and set lines, but many are caught in pound nets, seines, etc., set primarily for other fish. The principal fisheries are in the Great Lakes, Delaware River, and Sacramento River. The present yearly value of the yield is about \$300,000. Very important secondary products are derived from the sturgeon, namely, caviar, isinglass, and oil.

The sturgeon fishery is declining, and affords a remarkable illustration of the comparative facility with which the supply of river and lake fishes may be exhausted by indiscriminate fishing. In some localities the change in the sturgeon fishery within a single decade has been from a condition of great abundance, with little appreciation of the value of

the fish, to active prosecution of the fishery without regard to season, age, or spawning state, resulting in practical extermination and the suspension of fishing operations. Considering the entire country, it is estimated that during the past decade the decrease in the sturgeon catch has been 60 to 80 per cent. Much of the decline in some places is attributable to the destruction of the young, which linger near the mouths of rivers and, becoming entrapped in nets and pounds, have been killed on account of the annoyance caused the fishermen.

The common sturgeon of the Atlantic Coast attains a weight of over 500 pounds, but the average in recent years is not more than 150 pounds. The lake sturgeon reaches a weight of about 200 pounds; the average at the present time is 60 pounds. The known maximum weight of the Pacific white sturgeon is 848 pounds, and those weighing 500 pounds or more were not rare in the Columbia River some years ago, when the average weight was fully 150 pounds; but at present, as well as in the Sacramento River, the average is much less.

The spawning time of the sturgeon is spring and summer. When fully mature, the ova constitute from 20 to 30 per cent of the total weight of the female. When ripe, the eggs are free from the ovarian walls and lie loose in the abdominal cavity. The number of eggs produced by the common Atlantic sturgeon is from 1,000,000 to 2,500,000. The spawning of the anadromous species takes place in either the fresh or brackish waters of the streams. The lake sturgeon prefers rocky ledges near the shores of lakes. When deposited naturally the eggs soon become glutinous and adhere to sticks, weeds, brush, and other objects. The diameter of the egg is $\frac{1}{4}$ inch.

The culture of the sturgeon has not been systematically carried on in the United States or Canada, although the time seems opportune for rendering aid to nature in order to keep up the supply. Experimental work indicates that there are no insurmountable obstacles in the way of extensive artificial propagation, although the work presents some unusual difficulties.

One of the drawbacks met with in the Atlantic rivers is that of obtaining ripe male and female fish simultaneously. The important fact has been determined, however, that both eggs and milt may be cut from live or recently killed fish and fertilization be thus successfully accomplished. In order to secure the milt, pieces of testes may be obtained and the milt squeezed therefrom through a coarse cloth.

A large proportion of the females taken at the fishing centers are not ready to spawn when caught, and their retention in the crude pens used by the fishermen, together with the rough handling they receive, appears to render their eggs incapable of fertilization. The successful penning of the fish pending the ripening of the eggs and milt would greatly add to the success of this work, as the spawning season in a given place usually extends over a number of weeks.

The glutinous nature of the sturgeon's egg has been a drawback in the propagation experiments heretofore conducted. The eggs become

viscid in about 20 minutes after fertilization and stick together in masses of various sizes. This interferes with their aeration, lowers the vitality, and leads to the attack of fungus. The practice heretofore adopted for overcoming this condition has been either to spread the eggs in very thin layers on the hatching-trays prior to the development of the adhesive quality, so that after becoming fixed they would be properly aerated, or to stir them continuously for several hours in order to overcome their adhesiveness. The high degree of success attending the hatching of the glutinous eggs of the flatfish and the wall-eyed pike indicates that the difficulty encountered with the similar sturgeon egg may be readily overcome. By gently stirring recently fertilized eggs with a mixture of dry cornstarch and water or fine swamp muck and water, the tendency of the eggs to stick together and to other objects is avoided through the partial coating of the individual eggs with particles of starch or dirt. Other substances that will remain suspended and not be dissolved in water can doubtless be employed to advantage. Swamp muck is probably the best, because cheapest and most easily obtained; 2 quarts of it may be mixed with 10 gallons of water, which will be sufficient to render non-glutinous about 3 gallons of eggs; the same proportion of water, eggs, and cornstarch is recommended. After being transferred to the hatching station, the eggs may be placed under running water and the superfluous foreign particles washed away before being placed in the hatching apparatus.

The apparatus used in hatching sturgeon eggs has been chiefly boxes placed in the open water of the river. The glutinosity being overcome, there seems no reason why hatching may not be conducted in the automatic shad jar or in other modern appliances.

In the experimental hatching operations many eggs have been lost through attacks of fungus, induced by the character of the apparatus employed. The use of floating-boxes in open water has led to the loss of eggs by storms, rough water, and sudden changes of temperature.

The incubation period is about 7 days in water having a temperature of 62° to 66° F. The outline of the fish appears in 48 hours.

The question as to whether eggs of the common sturgeon can best be hatched in fresh or brackish water is not yet determined, but the indications are that brackish water is preferable. One reason is that the eggs are less liable to attacks of fungus in such water.

An attempt to rear artificially hatched sturgeon at Northville was unsuccessful, owing to the failure of the young to eat. The mouth of the sturgeon fry is very small, and the food is largely of a microscopic character, consisting of unicellular algæ, infusoria, insect larvæ, etc.

In Europe, where the sturgeon fisheries are vastly more important than in America, the results of experiments in sturgeon-culture have scarcely been as satisfactory as in this country. No method of separating glutinous eggs except by stirring seems to have been devised, and the same difficulty has been found in obtaining fish with ripe spawn and milt. The retention of fish in inclosures has not generally been successful.

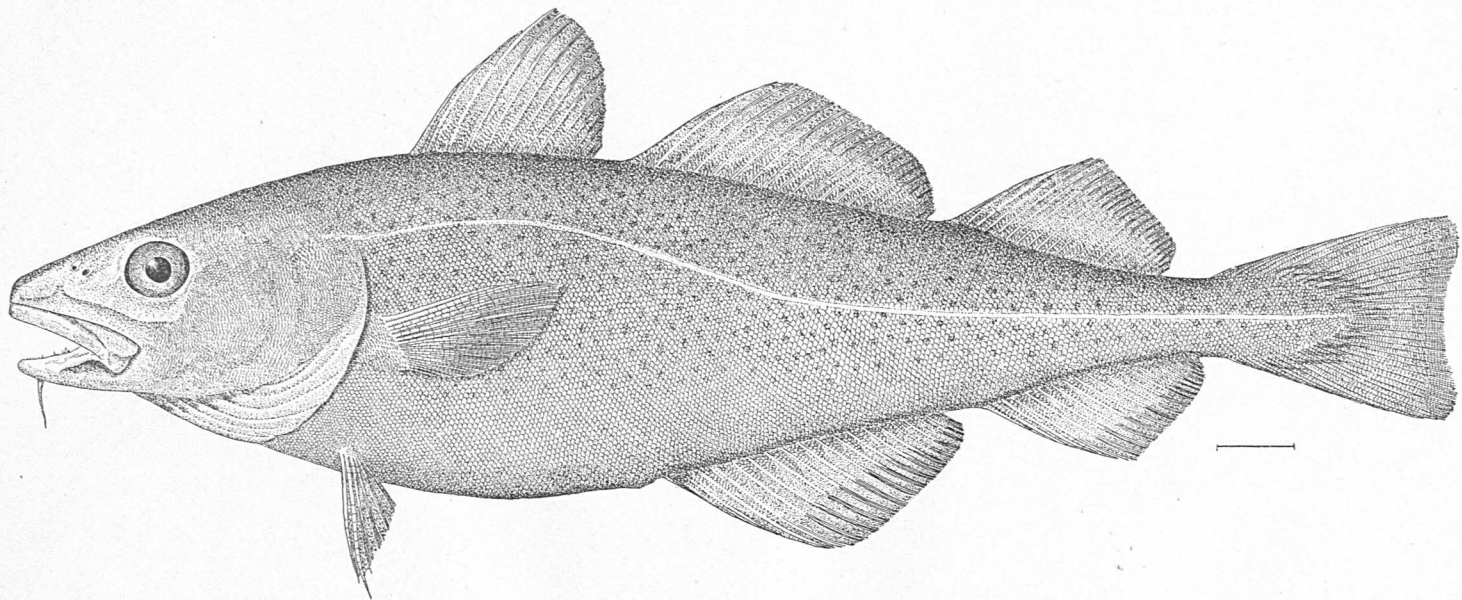

GADUS CALLARIAS. *Cod.*

THE COD.

DESCRIPTION OF THE FISH.

The body of the cod is moderately long, compressed and tapering behind; the greatest depth is about one-fourth its length. The large head is narrowed anteriorly and is contained $3\frac{1}{2}$ to $4\frac{1}{2}$ times in the body length. The mouth is large; the lower jaw is included within the upper when the mouth is closed; the maxillary extends to about middle of eye. The diameter of the eye is about half the length of the snout and one-fifth that of the head. There is a conspicuous barbel on the chin. The number of dorsal fins is 3 and of anal fins 2; the dorsal rays are usually about 14, 21, and 19 in the respective fins, and the anal rays are 20 and 18. The ventral fins are well developed, with about 7 rays. The cycloid scales, with which the body is covered, are very small. The air-bladder is large and thick. The color varies greatly, depending on food, kind of bottom on which found, and other conditions. Fish taken offshore in deep water are usually olivaceous on the back and whitish beneath; the so-called rock cod, found in shoaler water among rocks and kelp, vary in color from green to deep red. The back and sides are covered with small, round, reddish-brown spots. The lateral line is conspicuous, of a whitish color. The fins are dark.

From other species of the family, taken in the same waters, the cod is readily distinguished. From the haddock it differs in having a pale, instead of a black, lateral line; in its spots (absent in the haddock), and in its larger maxillary bone, which reaches past the eye, while in the haddock this bone does not extend to the eye. The features distinguishing the pollock from the cod are the smaller size, the projecting lower jaw, the uniform coloration above, the sharp snout, the smaller barbel, etc. The hakes have only 1 anal and 2 dorsal fins, a filamentous prolongation of the first dorsal ray, and a ventral fin consisting of two or three very long filamentous rays.

The status of the cod of the North Pacific Ocean is somewhat uncertain. It has generally been considered identical with the Atlantic species, but its smaller air-bladder and other features may entitle it to recognition as a distinct species.

RANGE, MOVEMENTS, FOOD, ETC.

Cod are widely distributed in the North Atlantic Ocean. To the north they range far beyond the Arctic Circle, and to the south as far as Cape Hatteras, although they are not common south of New Jersey.

The cod of the North Pacific Ocean is found from Bering Sea south to Oregon and Japan.

The movements of cod are not well understood. They go in schools, but in much less dense bodies than do mackerel, herring, and menhaden, and when moving from one ground to another they are in more compact schools than when on the feeding-grounds. The movements on and off shore and from bank to bank are due to several causes, among which are the effects of water temperature, the presence or absence of food, and the spawning instinct. In the winter months there is a well-marked movement of large bodies of codfish to the shores of the New England and Middle States, and important fisheries are there carried on in regions from which cod are absent at other times. This movement seems to be chiefly for the purpose of finding shallow grounds for spawning. That the cod sometimes makes very long journeys is shown by their capture on the New England coast with peculiar hooks in their bodies which have been identified as similar to the hooks employed by the French cod fishermen on the Grand Banks.

Although sometimes found in shallow water, cod are essentially deep-water fish, preferring water from 20 to 70 fathoms deep and being found even at a depth of 300 fathoms. Those caught for market are usually taken at depths of 20 to 40 fathoms.

The cod takes its food on the bottom, at the surface, or at intermediate points. It is an omnivorous and extremely voracious feeder, consuming all marine animals of suitable size. Favorite articles are bivalve mollusks, crabs, lobsters, starfish, and fish. Among the fish consumed in large quantities are capelin, lant, herring, alewives, menhaden, mackerel, and haddock, although many others are also eaten. The abundance and movements of such fish have an important relation to the presence and abundance of cod in a given region.

WEIGHT AND GROWTH OF COD.

The largest cod recorded from New England waters weighed 211½ pounds and was over 6 feet long; it was taken on a trawl off the northern Massachusetts coast in May, 1895. The capture of a number weighing from 100 to 175 pounds could be cited, but those exceeding 100 pounds in weight are by no means common, and even 75-pound cod are not numerous. The average weight of the large-size cod caught in the shore waters of New England is about 35 pounds; on Georges Bank, 25 pounds; on the Grand Banks and other eastern grounds, 20 pounds; the average weight of the small-size fish caught on all these grounds is about 12 pounds.

Observations in Massachusetts of the rate of growth of the cod show that those 1½ to 3 inches long are about 6 months old; those 9 to 13 inches long, and weighing 7 or 8 ounces, are 1½ years old; those 18 inches long, and weighing 2 to 2¼ pounds, are 2½ years old; and those about 22 inches long, and having a weight of 4 to 5 pounds, are 3½ years old.

SPAWNING.

The principal spawning time of the cod on the New England coast is winter, but the season begins as early as November and continues until April. Spawning fish are occasionally caught from October until May. The spawning period for an individual fish is greatly prolonged, and probably covers six or eight weeks, only a small percentage of the eggs maturing at one time. The male and female cod may attain sexual maturity when weighing only $3\frac{1}{2}$ or 4 pounds. The ages of normal fish having these weights are supposed to be three to four years.

When impelled by the spawning instinct, the cod seek the shoal waters of the coast or banks in schools consisting of both sexes. The female is less active than the male at this period, and probably rests quietly on the bottom while discharging the eggs. There is no evidence to show that the sexes are paired or in close proximity during the act of spawning. On the contrary, it seems likely that fertilization is generally accomplished by accidental contact of the sexual products as they are swept about by the elements, having risen to or near the surface as soon as extruded.

The cod is one of the most prolific fishes. The ovaries of a 21-pound fish have been computed to contain 2,700,000 eggs, and a 75-pound cod has been estimated to have 9,100,000 eggs, these figures being deduced by careful weighing or measuring of a known number of eggs. The egg is from $\frac{1}{16}$ to $\frac{1}{7}$ inch in diameter, the smallest fishes having the smallest eggs; the average size may be taken as $\frac{1}{8}$ inch. The approximate number in a fluid quart is 337,000.

The destruction of cod eggs in nature is necessarily large. The principal loss is probably through failure of impregnation, the eggs losing their ability to become fertilized and the milt its vitality very soon after being thrown from the fish. Incalculable numbers are thrown on the shore by the waves and there die. Cod eggs are also destroyed by numerous animals, including fish, birds, and invertebrates.

COMMERCIAL IMPORTANCE AND FOOD VALUE.

The cod is one of the most valuable of all food-fishes, and in the United States ranks as the most prominent commercial fish. In the matter of persons engaged, vessels employed, capital invested, and value of catch, the taking of cod in the United States is more extensive than any other fishery for fish proper.* The number of vessels which fish wholly for cod or take cod in noteworthy quantities, together with other "ground fish," is not less than 600, of over 25,000 net tons burden, carrying about 7,000 men, and with a value of \$3,000,000, besides which there are very large fisheries carried on from boats and small vessels of less than 5 tons burden. The approximate annual value of the cod

* The oyster fishery is the most important branch of the fishing industry of the United States.

catch in recent years is about \$3,000,000, a sum representing the first value of the fish. The weight of the fish as landed from the vessels (fresh, split, and salted) is about 100,000,000 pounds.

The cod fishery is prosecuted in all the coastal States from Maine to New Jersey, being most important in Massachusetts and Maine. Gloucester and Boston are the principal fishing centers. On the Pacific coast there is an important fishery in Alaska, carried on by San Francisco vessels.

Cod are taken with hand and trawl lines, baited with fish, squid, etc., and fished from small boats or the vessel's deck. The principal grounds in the Atlantic are the famous "banks"—Grand, Georges, Western, Quereau, etc.; on the Pacific coast the Shumagin Islands are the chief grounds. Small quantities are taken in traps at places on the New England shore.

ARTIFICIAL PROPAGATION.

The cod is propagated artificially on a more extensive scale than any other marine fish. Artificial hatching was first undertaken at Gloucester, Massachusetts, in the winter of 1878-79, and has since been regularly prosecuted on an increasingly large scale at both Gloucester and Woods Hole. Up to and including the season of 1896-97, the number of cod fry liberated by the Commission on the east coast was 449,764,000. The output of fry in the last-named year was 98,000,000. The unmistakable economic results which have attended these efforts warrant all the time and money devoted to them and justify the greatest possible expansion of the work.

COLLECTING EGGS ON THE FISHING-GROUNDS.

The following methods are pursued in collecting cod eggs for the United States Fish Commission station at Gloucester.

As cod are abundant in Ipswich Bay during the winter, vessels from Gloucester, varying in size from 10 to 70 tons, engage in fishing there, starting from Kittery Point, Maine, or Portsmouth, New Hampshire, where they market their catch, secure bait, and obtain supplies. At the beginning of the cod season (which usually opens from the middle to the last of November) arrangements for the board of the men, dory and building hire, transportation of eggs, etc., are made with persons at Kittery Point and permission to place spawn-takers aboard the fishing vessels is obtained, with the understanding that they will be allowed to take eggs from the fish secured, that they be given the freedom of the vessel in order to properly care for the eggs, and that no charges be made against the Commission except that 25 cents be paid for each meal furnished the spawn-takers. After these arrangements are made the men are directed to board such of the fleet as are at the time meeting with the best fishing, but as the fish are not of uniform abundance in the bay it is necessary to keep a vigilant watch on each vessel's catch as it is landed, daily, to know where to place the spawn-takers to the best advantage.

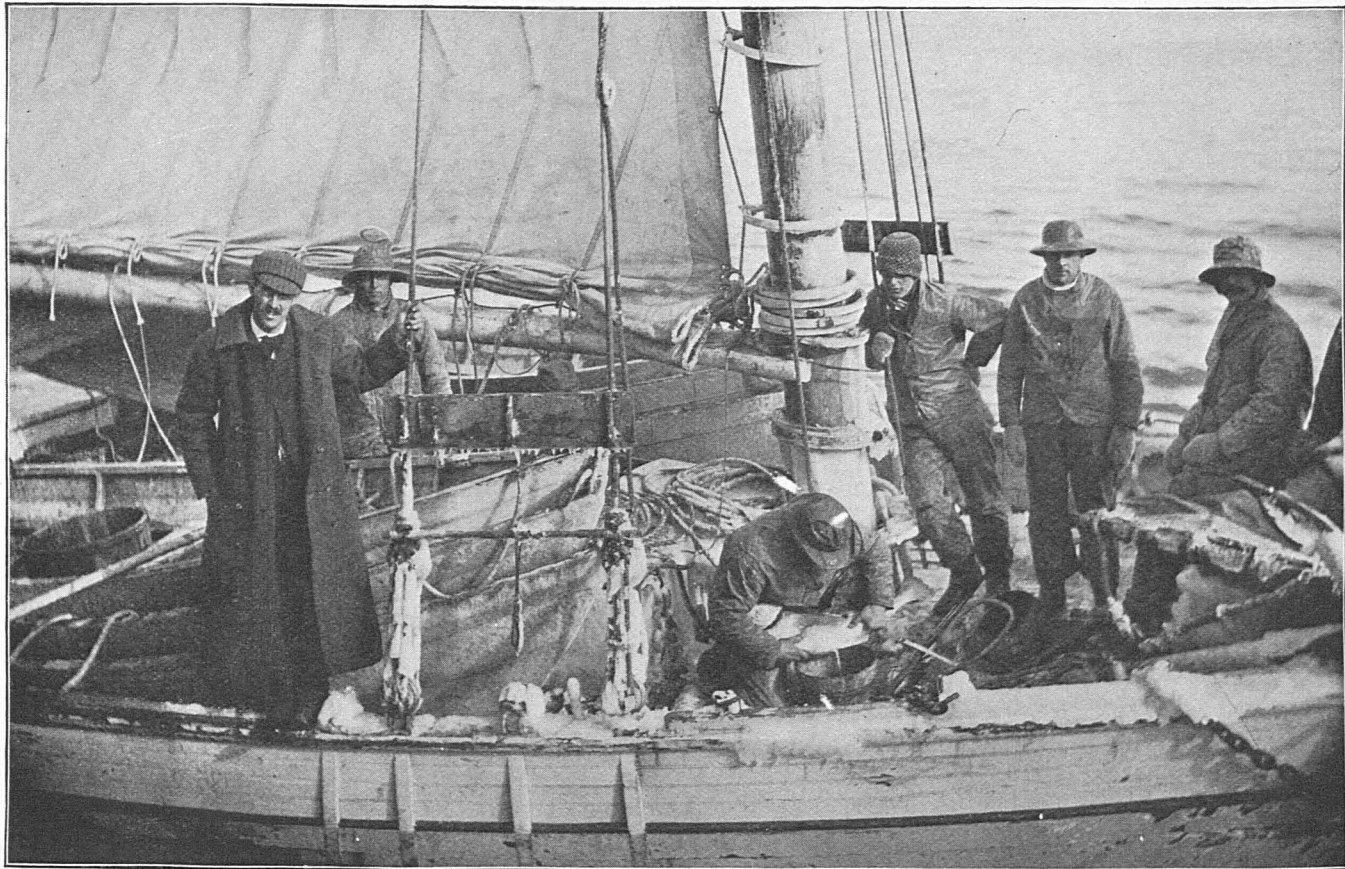

STRIPPING COD ON VESSEL.

A spawn-taker's outfit consists of a water bucket or pail, a dipper, a siphon, a thermometer, and a tin spawn-kettle about 2 feet long, 1 foot wide, and 8 to 9 inches deep; the kettle has a cover and handle.

When new spawn-takers are employed they are instructed in the work and sent out in vessels with the experienced men to familiarize themselves with the methods. The spawn-takers ordinarily leave their boarding-places at 1 o'clock in the morning (though the time varies somewhat, according to the weather) and join the boats anchored in the harbor of Kittery or at Portsmouth. During moderate weather the men frequently go aboard before midnight, as the vessels must sail when the tide is favorable, to avoid getting becalmed or meeting a head tide, either of which might prevent them from reaching the fishing-grounds in good season.

After joining the vessels, the spawn-takers usually assist the fishermen in getting under way, managing the ship, etc., and on reaching the place where the nets or trawls are set—usually 6 to 10 miles distant—the spawn-takers help the crews in hoisting out and dropping the dories on the gear as each buoy is reached, the men remaining on the vessel's deck with the captain while the fishermen are hauling or under-running their gear, and until they return to the vessel with the fish.

As soon as the dories begin to arrive with fish, the work of the spawn-taker begins. As the fish are pitched aboard, the spawn-taker stands ready to examine each one and select those that may contain ripe eggs or milt. As the dories are usually picked up in the same order in which they are dropped, there is opportunity to strip the fish without much hurry, but sometimes several are picked up in a short space of time, and if a large quantity of fish is landed the catch remains on deck until the spawn-taker can overhaul it. In bad weather, however, when the fish would be in danger of being washed away, they are put in bins on deck and can be pitched from one bin to another by the spawn-taker as the condition of each is determined. Usually one of the crew assists in this work and often renders valuable assistance. Great care is taken not to get any green or dead eggs with the good ones and to keep the eggs as free from foreign matter as possible; but in rough weather, when the vessel is pitching or rolling heavily, vigilance in these respects is necessarily somewhat relaxed.

The spawn-taker seizes the fish by the tail, places the head under the left arm, if it is not too large, leaving the right arm free for stripping the fish, which is done in the usual way. Only live fish or fish recently dead are used.

The eggs are first taken in a common pail, the inside of which has been moistened with water. Then a sufficient quantity of milt to fertilize the eggs is added and thoroughly mixed with them and allowed to remain from 10 to 20 minutes, or longer, after which water is added and the eggs are carefully cleaned by siphoning off the old water and putting in fresh water until all the slime and milt are drawn from the pail. The good eggs, which rise to the surface of the water, are

then transferred to the spawn-kettle containing clean water and the poor or dead eggs are thrown away.

All the eggs obtained on a given vessel are kept in the kettle until the receiving-house on shore is reached, the water on the eggs being changed at intervals during the passage in; and to keep the temperature uniform, the eggs are shifted from one part of the vessel to another, according to conditions. Sometimes, when the sea is very choppy or rough, the pail can not safely be used, as the eggs will spill out, and they are then stripped directly in the spawn-kettle and cleaned as well as possible.

It was formerly the practice to take cod eggs in a small quantity of water, but during the season of 1896-97 it was determined to test the relative efficacy of the so-called wet and dry methods of fertilization. Some of the spawn-takers were instructed to employ the dry method and others the wet method. The experiments show that when eggs were taken by the dry method a much larger percentage was fertilized than when taken in water. Eggs from fish caught on trawl lines invariably yield a larger percentage of fry than those from fish caught in nets, although fine eggs are frequently obtained from net fish. The explanation seems to be that fish caught in nets soon become entangled and are either drowned, or nearly so, shortly after being meshed; they struggle a great deal more than fish on trawls and the greater part of them are dead when taken into the boats, many of them being scaled, which indicates severe exertion in trying to escape. Trawl fish, on the other hand, are almost always alive and active when taken from the water, and very few fish without scales are found unless the gear has been out a long time or has been set during a heavy storm, when, of course, many of the fish will be dead.

Better results are obtained from eggs taken when the weather is fairly cold than when it is warm, as when the temperature is high it is difficult for spawn-takers to keep the water containing the eggs at a safe temperature, and before the egg house on shore is reached there is almost always a heavy loss. When the weather is too cold for eggs to be kept on the vessel's deck the spawn-takers put them below the deck, where the temperature will be suitable.

Many difficulties and much exposure are encountered by the men who collect cod eggs on the fishing vessels, and during severely cold and windy weather, when the deck is covered with ice and the fish freeze stiff in the dories before they reach the vessel, it is practically impossible to get good eggs. During boisterous weather, when the fleet succeeds in hauling the gear only once or twice a week, the greater part of the catch is generally dead when taken. A spawn-taker often secures a good lot of eggs and can find no ripe milt fish, but in this event he will, if the weather permits, visit the nearest vessel in quest of milt. Sometimes there is a school of milt fish in the bay and very few female fish, and a vessel may catch several thousand pounds of cod day after day without finding ripe spawn in any of them, while another

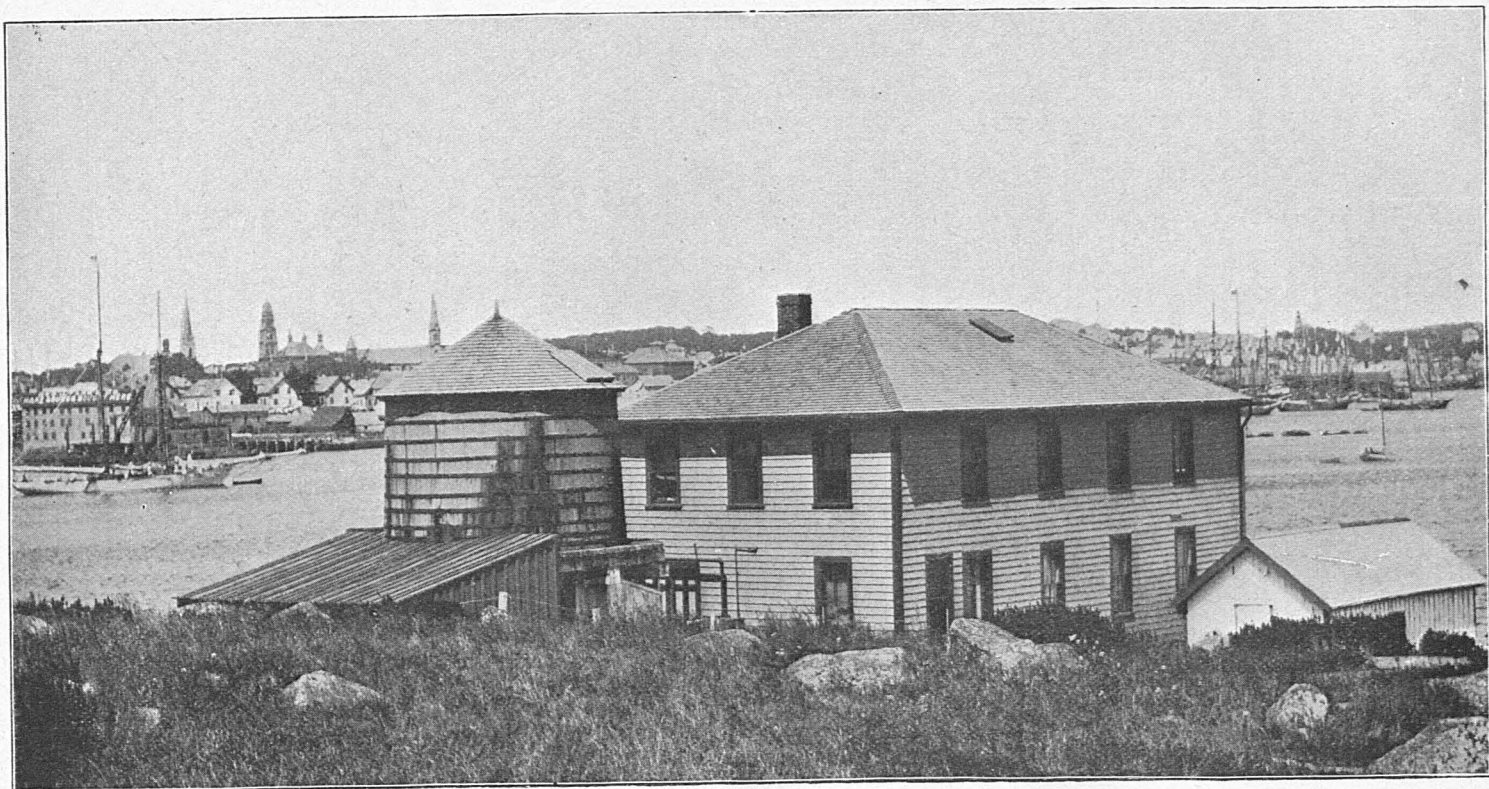

GLOUCESTER STATION

vessel, fishing only a short distance away and not catching many fish, will get a comparatively large number of spawners.

The spawn-takers are instructed not to take eggs from fish that have died on trawls or in nets, although fine lots of eggs are often taken from fish that die in the dories before they reach the vessel, showing that the eggs do not die immediately after the fish expire. The vitality of the eggs after the death of the fish varies in different cases and depends on the conditions of the eggs and the fish at the time the fish are caught, the state of the weather, etc. An experienced spawn-taker can almost always distinguish readily between good and poor eggs, although it is not always possible to determine whether or not a given lot of eggs will live. As the weather and the nature of the school of fish in the bay regulate the collection of eggs, the results of a season's work can not be estimated in advance. It has been observed that roe fish are found in largest numbers previous to an easterly storm and when the wind is from the south or west. During heavy westerly winds cod appear to approach quite close to the beach, and when the wind blows from the eastward and the sea begins to rise, they leave for deeper water.

When fishermen are hauling their nets and trawls, they frequently notice spawn being emitted from fish when they are landed in the dories. Such fish are laid away on their backs in the stern of the boat and when the vessel is reached are carefully passed to the spawn-taker, many eggs that would otherwise be lost being thus saved.

When the price of fish is low at Portsmouth or the wind is unfavorable for making that harbor, some of the fleet go to Rockport to sell their fish, and should spawn-takers be on such vessels they immediately take their eggs to Gloucester when the vessels arrive in Rockport.

Usually the fishing vessels return to Kittery Point between 1 o'clock and 10 o'clock p. m. Immediately on landing, the spawn-takers carry their collections to the egg-house on shore, where the spawn is carefully examined, cleaned, packed, and shipped to Gloucester by first train. In shipping eggs large fruit jars are used. About 350,000 eggs are put in each jar, the jar is filled with water, the top is securely fastened, and the jar is placed horizontally in a large iron kettle made especially for the purpose and holding five jars. The jars are wrapped in burlap before they are put in the kettles to prevent them from breaking, and when necessary, snow or ice is put in each end of the kettles to keep the temperature uniform during transit, but it is not allowed to come in direct contact with the jars.

A messenger usually accompanies the eggs and gives them constant attention until they are delivered at the station. The snow or ice is removed from the kettles, if the temperature falls too low, and replaced, if necessary, the messenger making frequent use of a thermometer.

In preparing eggs for shipment without messenger, they are first cleaned carefully by drawing off all dead eggs or dirt, then put in large fruit jars in the same manner as when they are shipped to Gloucester, and the jars are packed horizontally in large wooden cases holding nine

jars each. Rockweed or moss, together with ice or snow, is used in packing them, the former being placed around the jars and the latter put in the bottom, sides, and top of the case to keep the eggs cool. Successful shipments are often made by express.

Some difficulty has been experienced in keeping large lots of eggs over night at Kittery Point, as the facilities are insufficient for changing water or for spreading the eggs out to overcome the injurious effects of prolonged crowding; but when it is necessary to so retain them, they are put in McDonald jars in which the water is changed as often as the supply will permit. As the water in the harbor is partly fresh and unfit for this purpose, it is necessary for spawn-takers to bring in a supply from the open bay in large transportation cans.

CAPTURING AND PENNING BROOD COD.

Practically all of the cod fry hatched at Woods Hole prior to 1896 represented eggs taken from penned fish. Some of the cod collected for breeders are caught by the crew of the Fish Commission schooner *Grampus* and some are purchased from commercial fishermen. Two or more smacks usually engage in fishing for the station during the collecting season, which is from about October 1 to November 30. The grounds resorted to are east of Nantucket and around Block Island. The fish are taken with hand lines fished from the deck while the vessel is drifting, in water from 10 to 40 fathoms deep. Those taken in the shoaler water are preferable to those coming from deep water, as the change to the shallow cars in which they are held at the station is less pronounced. Great care is exercised in catching the fish, for when hastily hauled up from deep water they are very liable to be "poke-blown," that is, they have their stomachs turned inside out through the mouth. When drawn in with moderate speed, they become adapted to the gradually diminishing pressure and do not suffer injury. It is also important in unhooking the fish not to injure its mouth any more than is absolutely necessary, as the wound caused by the hook frequently spreads and forms a large sore and eventually kills the fish. All the vessels which collect cod for the station are provided with wells in which the fish are placed and held while in transit.

When a vessel arrives at the station with cod, the fish are immediately transferred with dip nets from the well to live-cars 16 feet long, 6 feet wide, and 5 feet deep, which are constructed of wood and divided into two compartments by a crosswise partition. As the fish obtained from smacks are paid for by the pound, it is customary to weigh about 10 per cent of each load and estimate the total weight by the average of those weighed. While being weighed, the cod are also counted, about 500 being put in each car. The cars are moored in the middle of a pool or basin protected on all sides by a wharf, which breaks the force of the sea in stormy weather and affords a sheltered place for handling the fish and taking the eggs.

Cod take little or no food when spawning. The impounded brood fish are often tempted with fresh fish and with fresh and salted clams,

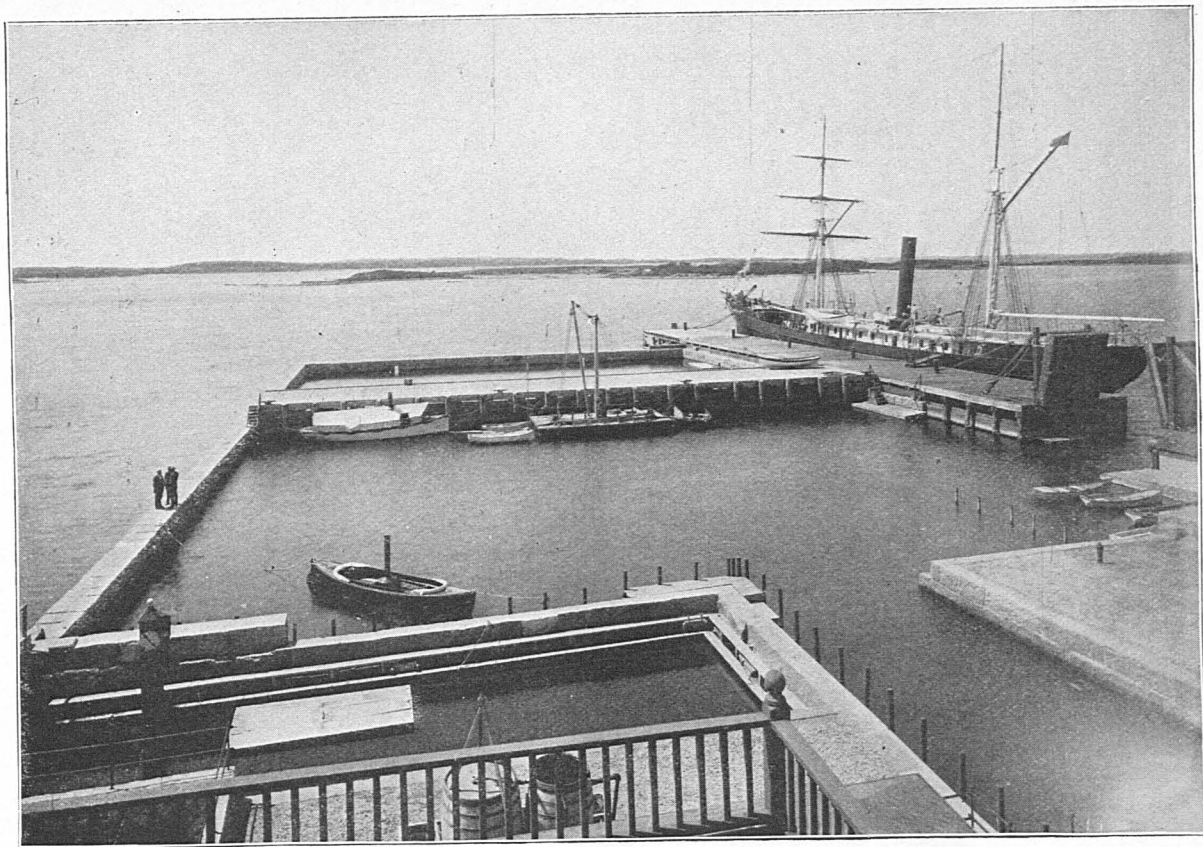

POOL FOR RETAINING BROOD FISH AT WOODS HOLE. THE ALBATROSS AT WHARF.

but they can rarely be induced to eat. A certain percentage of the penned fish die and are removed at once from the cars. The development of the sexual organs is noted when the dead fish are taken out. Fish about ready to spawn are placed in a separate car and carefully watched. They are examined two or three times a week and any ripe eggs are taken.

In taking and fertilizing the eggs of brood cod the same general methods are followed as are adopted on the fishing vessels in Ipswich Bay. The spawn-taker grasps the ripe fish near the tail with his left hand and holds the fish's head either between his body and left arm or between his thighs, using his right hand to strip the fish. The eggs are usually taken in a bucket. Both the dry and wet methods of fertilization are used at Woods Hole. Usually about 80 per cent of the eggs taken are fertilized. Unlike many other fishes artificially propagated, the cod does not yield all of its eggs at one time. After expressing all the eggs possible from a given fish, it is returned to the live-car, and in a few days will have matured more eggs, which are then taken. When the ovaries have discharged all their eggs, the fish is released.

In recent years from 1,600 to 9,000 cod have been penned annually in the protected basin at Woods Hole. Only from one-ninth to one-third of these, according to the season, yield good eggs.

CHARACTERISTICS OF COD EGGS.

Cod eggs are nearly transparent, and float at the surface of the water when first taken. They vary in color from a pale green to a deep red, those having the green color being the best. Good results are seldom obtained from the red eggs, and those of a deep red color almost invariably die in three or four days after being received. Unless the density of the water is low, the eggs normally float during the entire hatching period. However, it frequently happens that, owing probably to the accumulation of sediment, the eggs gradually sink during the last third of the incubation period, and finally mass together on the bottom of the hatching-box; here they would quickly smother but for the current.

Floating eggs are not necessarily good ones, for unfertilized and injured eggs usually float 18 to 36 hours before going to the bottom. Unfertilized eggs may be readily detected, as they have no disc which marks fertilization and have a milky appearance. The dead eggs quickly sink, and are easily distinguished from the sound eggs by a white spot in the center.

Eggs received at the hatchery are transferred from the vessels in which they came to Chester jars partly filled with water, and in 10 or 15 minutes they rise to the surface in a dense mass. The eggs are put in each jar to the depth of an inch, a quantity representing approximately 379,000 eggs. If the hatchery is full, about a fifth more eggs may be put in a box, the maximum number that may be safely carried being 450,000. The first measurements are carefully made, as they form the basis for subsequent estimates. As soon as the eggs are measured they are transferred to the hatching-boxes with dippers.

THE APPARATUS USED IN HATCHING COD.

The apparatus and methods employed in cod-culture are the outgrowth of long experience and study and have as their special features the closest possible simulation of natural conditions. The apparatus now in general use is the so-called McDonald or automatic tidal box. The boxes are constructed in series of 12 or less, the number depend-

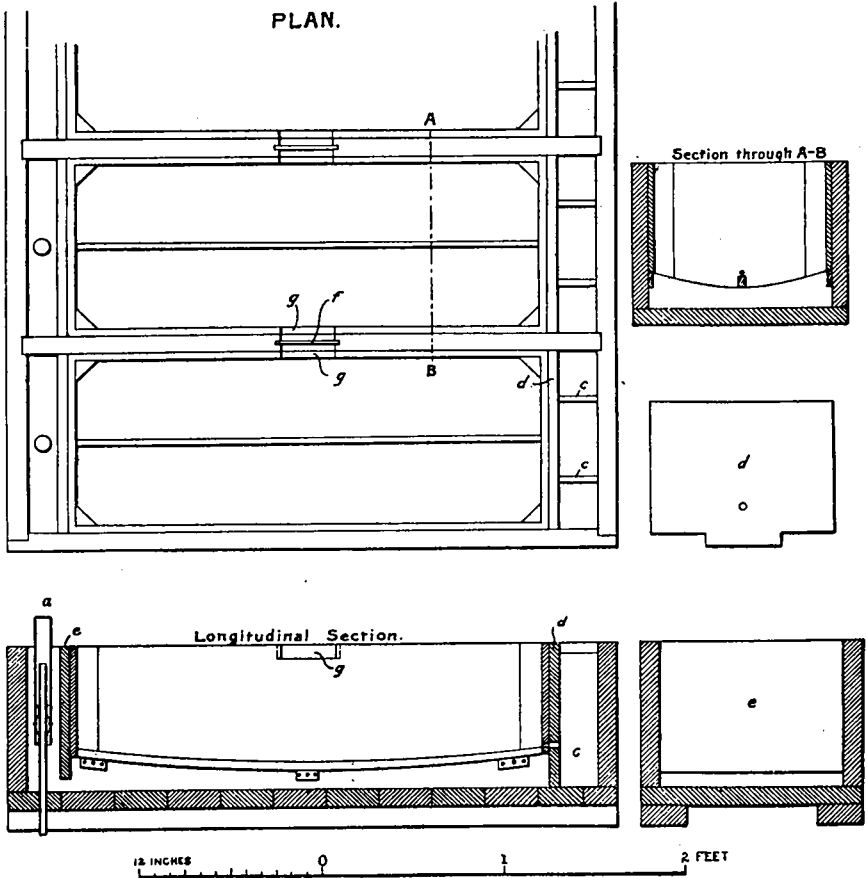
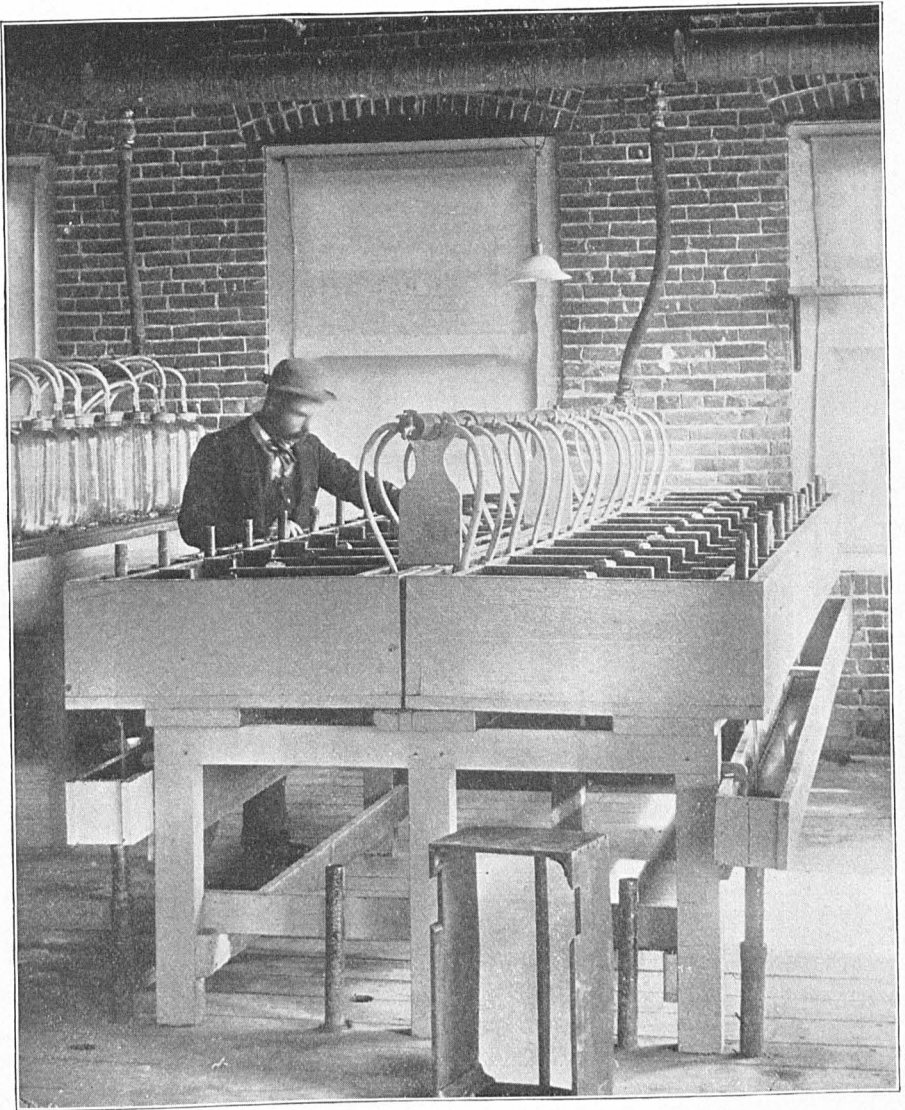

Diagram of Tidal Cod Hatching-Box.

- | | |
|---|---|
| A-B Points where cross-section is taken. | e, partition forming space at lower end of compartment. |
| a, siphon. | f, glass gate. |
| c, partitions forming upper pockets. | g, slot between adjoining compartments. |
| d, partition forming space at upper end of compartment. | |

ing on the size of the hatching-room, the arrangement of the hatching-tables, or other conditions. The Gloucester hatchery has 8 tables of 9 boxes each, and Woods Hole 14 tables of 12 each. At Gloucester 25,000,000 eggs can be hatched at one time, and at Woods Hole 65,000,000. For a wooden framework to accommodate 9 boxes such as are used at Gloucester the outside dimensions are: Length, 10



McDONALD TIDAL BOXES, USED FOR HATCHING COD AND FLATFISH.

feet; width, 3 feet 8 inches; depth, 11 inches. The table or trough is constructed of 2-inch lumber and raised to a convenient height by short, stout legs. The table is divided into 9 water-tight compartments by means of crosswise partitions of $1\frac{1}{2}$ -inch plank.

At Woods Hole the dimensions of the troughs containing 12 boxes are as follows: Length over all, 13 feet; width, 2 feet 7 inches; depth, 12 inches. The plank is $1\frac{1}{2}$ inches thick. The bottom of the trough is $2\frac{1}{2}$ feet above the floor. The compartments are separated by $1\frac{1}{2}$ -inch partitions and are 22 inches long, 12 inches wide, and $10\frac{3}{4}$ or 11 inches deep.

Two inches from each end of each compartment there is a 1-inch wood partition. The partition *d* at the supply or upper end of the compartment extends with its middle portion to the bottom of the trough, while the two sides extend only to within $1\frac{1}{2}$ inches of the bottom. The partition *e*, at the discharge or lower end of the compartment, extends its full length to within $1\frac{1}{2}$ inches of the bottom of the trough. Between the two partitions *d* and *e* in each compartment there is snugly fitted a movable box in which the eggs are placed. This box, which is constructed of $\frac{1}{2}$ -inch plank, is 9 to $9\frac{1}{2}$ inches deep in the center, but only 8 inches deep at the corners, the bottom sloping upward toward the sides and ends of the box and being covered with linen scrim. A wooden strip at the bottom, $\frac{1}{2}$ inch thick and conforming to the shape of the bottom of the box, extends the length of the box. The box rests on cleats in the corners of the compartments which keep the center of the box $1\frac{1}{2}$ inches above the bottom of the trough.

The space at the supply end of each compartment is divided into three pockets by 1-inch wood partitions. The middle pocket connects with the main compartment by means of a small hole ($\frac{3}{16}$ to $\frac{2}{16}$ inch) through the center of the partition and end of the box immediately above the lengthwise strip, and the two lateral pockets connect by a space at the bottom with the main compartment.

At Woods Hole the water used in hatching is pumped from the harbor to two tanks of about 18,000 gallons joint capacity. The water is led to the hatching-room through a 4-inch wooden pipe and is supplied to the hatching apparatus through a $2\frac{1}{2}$ -inch hard-rubber pipe which branches from the main pipe and runs directly over each row of tables. At Gloucester the main supply-pipe is of hard rubber, 3 inches in diameter; this leads from a tank of 15,000 gallons capacity, the bottom of which is about 6 feet above the level of the troughs. A small soft-rubber tube, provided with a rubber pet-cock, carries the water to the middle pocket at the back of each box. As the pocket is always full of water when the boxes are in operation, a considerable amount of water goes through the small hole with much force, creating a strong current in the box and keeping the eggs in constant rotary motion. This current is one of the principal features of the apparatus.

Much more water enters the middle pocket than can pass through the small hole into the box, and the surplus flows over the sides and

enters the main compartment from below, coming up through the scrim-covered bottom into the movable box.

The partition forming the pocket at the lower or front end of the box only extends to within $1\frac{1}{2}$ inches of the bottom, leaving a space through which the water runs from the compartment. In the bottom of the pocket there is an opening in which the vertical waste-pipe fits. This pipe is brass, $\frac{1}{2}$ inch in diameter and 10 or 11 inches long; the top of the pipe is 7 inches above the bottom of the table. The waste-pipes from the different boxes discharge into a trough which carries the water from the building.

A particularly important part, and the one which gives the name "tidal box" to the apparatus, is used in conjunction with the waste-pipe. This is a brass siphon-cap, which fits over the upper end of the waste pipe. The cap is a tube, closed at the top, 9 inches long and $1\frac{1}{2}$ inches in diameter. It is kept at any desired height on the waste-pipe by wire springs in the cap or by other means.

By virtue of the siphon attachment the water in each box rises to the height of the top of the waste-pipe and begins to run over. This partly exhausts the air in the cap, more water rushes in, and the pipe becomes filled with water; then the siphon begins to act and takes off the water to a level of the bottom of the siphon-cap. Usually the cap is pushed about half down the waste-tube, although the height of the water in the box after the discharge of the siphon is regulated by the manner in which the eggs are working. About 7 minutes are required for the water to be drawn down and the box to again fill, and approximately two-fifths of the water is taken off at each discharge. By this arrangement the water in the boxes is constantly rising and falling automatically; the movements of the waves are thus simulated, the eggs are kept in constant circulation, and fresh water is continually entering the boxes.

The Chester box was generally used in cod-culture up to a comparatively recent date, and is still occasionally employed in marine fish-cultural operations. The general object of its construction is the production of an automatic rise and fall of water, as in the McDonald box, although it differs from the latter in some essential particulars. It consists of a box of variable dimensions in which jars are placed for the reception of the eggs. A convenient size of box is $7\frac{1}{2}$ feet long, 2 feet wide, and $2\frac{1}{2}$ feet deep. From 4 to 8 large glass jars are arranged on wooden supports 7 or 8 inches above the bottom of the trough. Smaller boxes, to accommodate only 2 or 4 jars, are also used. The jars are about 9 inches in diameter and are of two heights—9 inches and 17 or 18 inches; they have straight sides and a flat bottom with a central half-inch hole.

The jar is placed in the box in an inverted position, with its bottom above the level of the top of the trough. The sea water supplying the trough enters the compartment at one end of the trough and escapes

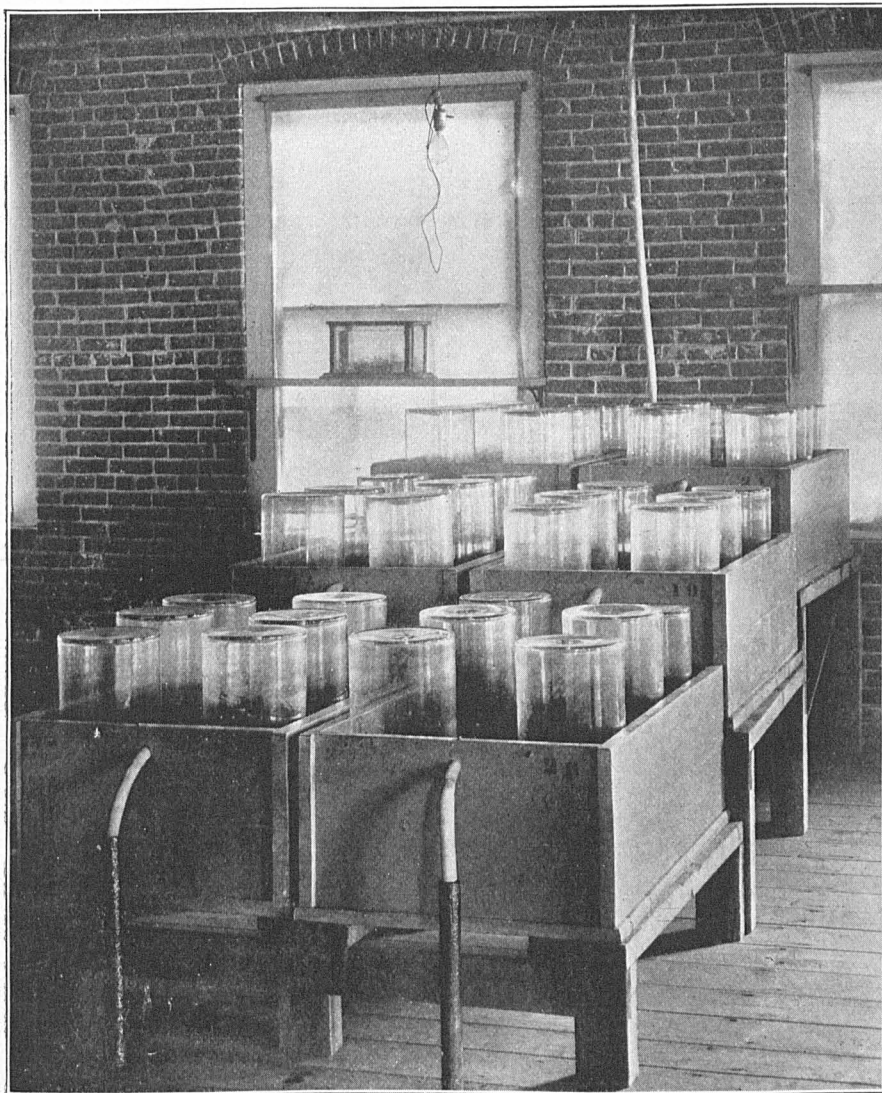

CHESTER BOXES.

by means of a siphon in the other compartment, running through a hole several inches below the top of the trough. The trough fills with water up to a level with the hole, when the siphon begins to act and takes off the water more rapidly than it enters, to a level with the inner end of the siphon, the fall being 4 to 5 inches. Air then enters the siphon, and it ceases to act until the water has again risen to the height of the discharge hole. The water thus rises and falls in the jars automatically, the interval between the successive discharges being regulated by the length of the inner arm of the siphon, the size of the tube, and amount of water supplied.

After the eggs are introduced into the jars a piece of cheese-cloth or linen scrim is placed over the top, and fastened by means of rubber bands. The jar is then inverted and placed on the wooden supports provided for the purpose, and the plug in the bottom removed to allow the escape of the air and the rise and fall of water. The number of eggs per jar is about 190,000 or 200,000.

DEVELOPMENT OF THE EGG.

The development of the cod egg is greatly influenced by the water temperature, which fluctuates from day to day and makes it difficult to state exactly when the eggs will hatch. With a high temperature the advancement of the egg through the different stages proceeds rapidly and can readily be appreciated with the unaided eye, while with a low temperature the development is slow and may be greatly prolonged by very cold water. With a mean temperature of 47° cod eggs begin to hatch in 11 days, although 2 or 3 additional days are usually necessary for all the eggs of a given lot to hatch. At 43° the time is 14 or 15 days, and at 38° it is 20 to 23 days. The best results are obtained when the temperature ranges from 41° to 47°. The hatching proceeds satisfactorily with the water at 38°, but with a lower temperature the incubation period is so long that the fry are very weak. On the natural spawning-grounds the water seldom gets below 38°, while at the stations after January 1 the water used for hatching rarely gets as warm as 37°, and often is as low as 31°; from the middle of January to the latter part of February it remains at about 32°. Since it is impossible to do even fair work when the water gets below 35°, it has been the practice to warm the water by passing it through a coil of pipe contained in a tank of warm water or by introducing steam directly into the water pipe whenever the hatchery water gets below 37°.

The water being at 47°, during the first 4 days the egg passes through the different stages of segmentation; at the end of that time the germinal area begins to assume the general form of a fish; and by the ninth day the fish is quite well formed, and may be readily seen with the naked eye. By the tenth day the embryo shows signs of life, and under the microscope the heart may be seen to beat.

Following is a table showing the approximate time required for cod eggs to hatch, with the water at the stated mean temperatures:

Mean water temperature.	No. of days.	Mean water temperature.	No. of days.	Mean water temperature.	No. of days.
31° F.....	50	37° F.....	23	43° F.....	14
32° F.....	40	38° F.....	21	44° F.....	13
23° F.....	35	39° F.....	19	45° F.....	12
34° F.....	31	40° F.....	17	46° F.....	11
35° F.....	28	41° F.....	16	47° F.....	10 or 11
36° F.....	25	42° F.....	15		

Moderately clear water is essential to the healthy development of the fry. If much sediment is present it collects on the eggs and acts very injuriously, often killing them. Sometimes eggs become so coated with sediment that the fry appear to be unable to burst the shell; some lots of eggs thus affected have been known to retain fry fully two weeks beyond the normal period of incubation.

With eggs carefully taken and fertilized, and clear water of a temperature from 41° to 47° F., it is possible to hatch from 70 to 85 per cent of the eggs, but when the temperature gets below 38° the percentage of fry hatched is only from 25 to 50, and the average for the season is thus greatly reduced. The number of fry hatched is determined by deducting the losses shown on the hatching-cards from the number of eggs originally in the box. One liquid ounce is estimated to contain 10,524 eggs.

CLEANING THE EGGS.

Owing to the accumulation of sediment and other foreign matters in the hatching-boxes, it is necessary to clean the eggs daily, running the sound eggs from one box to another through a slot, the dead eggs being left behind. The slots in the partitions dividing the hatching compartments correspond with similar slots in the boxes; they are 3 to 3½ inches long and 1½ inches deep, and are placed 3 inches from the front of the compartments. To begin the cleaning of a given row of boxes, a glass slip is fitted into the slot between the second and third boxes, the first box being left empty for the purpose of receiving the cleaned eggs from the second box. A wooden plug is then put in the current hole at the back of the second box, and the siphon cap is removed from the waste-pipe; this allows the box to fill with water, and the eggs, undisturbed by the current, rise to the surface. The water is allowed to enter the first box and to gradually fill it to the level of the waste-pipe, and is then turned off. A plug is next put in the waste-pipe of the box containing the eggs; the water rises till it reaches the slot, and then runs over into the first box, carrying the good eggs with it, while the dead eggs remain in the box. The regular water circulation is then established in the first box.

The inner box from which the good eggs have been removed is taken out and the remaining eggs are washed into one end and poured into

a glass graduate. The dead eggs quickly sink and the quantity, in ounces, is noted on a card attached to each box. If there are any good eggs in the glass they are saved; the spoiled eggs are thrown into the waste-trough. Both the inner box and the trough in which it rests are thoroughly washed and sponged after each change.

When the inner box is replaced it is made ready for the eggs to be transferred from the third box, and the same method is pursued until all the boxes have been cleaned. Eggs recently taken, being on the surface, run over very quickly, 5 or 10 minutes usually sufficing for the transfer of a box of 400,000 eggs; but when eggs become heavier, as a result of development, the cleaning takes much longer, as it is then necessary to run them into the lower part of the box (as in removing dead eggs) and to dip them out, care being taken to keep the lower end of the box in the water while manipulating them. As the loss of eggs has ceased by the time they reach this stage, everything in the box may be dipped over, and with care no damage is done the eggs.

THE FRY.

When the fry first hatch they are much curved in shape and show but little vigor. If the water is comparatively warm they rapidly straighten out and become stronger. At this stage they float at the surface, except when forced about by the current. As they get older they frequent the upper water less and if kept in the boxes till the mouth begins to functionate most of them remain on or near the bottom.

As soon as the first fry in a given box make their appearance the eggs are all run-over for the last time. As the fry are comparatively delicate they are handled as little as possible and with great care.

The fry are planted as soon as practicable. If all the eggs of a given lot have not hatched it is better to plant them with the fry rather than hold the latter until incubation is complete, for the boxes soon become foul from the accumulation of eggshells and the eggs will hatch in a very short time, especially as the water on the spawning-grounds is usually 3 or 4 degrees warmer than the water in the hatchery.

When the fry are to be removed from the boxes, preparatory to planting, a plug is put in the current hole at the back of the box, and in a short time most of them will come to the surface. They are then dipped out and put in transportation cans. About 200,000 fry may be safely carried in a 10-gallon can. Deposits are usually made on the natural spawning-grounds.

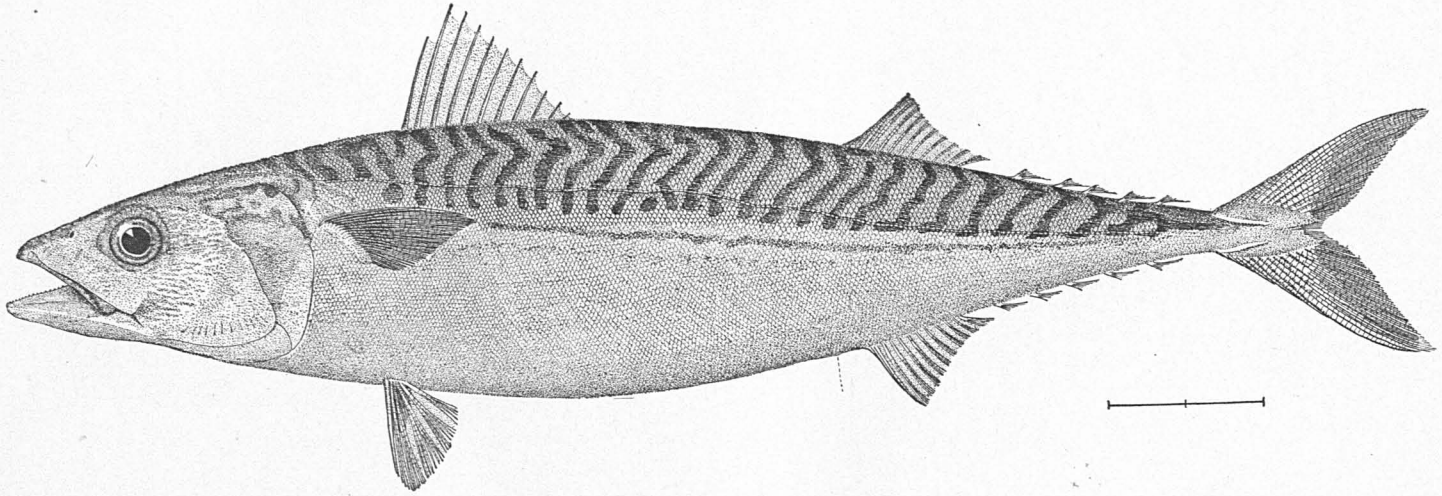

SCOMBER SCOMBRUS. *Common Mackerel.*

THE COMMON MACKEREL.

DESCRIPTION, SIZE, ETC.

The genus *Scomber*, of which the common mackerel (*S. scombrus*) is the leading representative, is distinguished from related genera of scombroid fishes of the Atlantic coast (*Auxis*, the frigate mackerels; *Gymnosarda*, the little tunnies; *Thunnus*, the great tunnies; *Sarda*, the bonitos, and *Scomberomorus*, the Spanish mackerels and kingfish) by the small size of the species, by the absence of a median keel on each side of the caudal peduncle, by a short spinous dorsal fin having 9 to 12 spines, by the pattern of coloration, and by a number of other characters.

The body of the mackerel is fusiform and but little compressed laterally. The standard length is $3\frac{1}{2}$ times the depth. The caudal peduncle is slender, with a small keel on either side. One-third of the total length without tail consists of the head. The eye is rather small, its diameter being only one-fifth the length of the head. The mouth is large and armed with a row of small slender teeth in each jaw. There are two dorsal fins, the anterior containing 11 spines and the posterior 12 rays, following which are 5 finlets; the formula of the anal fin is 1 spine, 11 rays, and 5 finlets. The scales are very small, numbering several hundred along the lateral line. The color is dark blue above and white below. About 35 dark wavy vertical streaks mark the back.

The common mackerel closely resembles the other species of the same genus found on both the Atlantic and Pacific coasts, namely, the bull's-eye, chub, or thimble-eye mackerel (*S. colias*), but is separated from it by the absence of the air-bladder, more dorsal spines, smaller eye, and somewhat different markings.

The length of the full-grown mackerel is 17 or 18 inches, but fish a little over 20 inches long, and weighing upward of $3\frac{1}{4}$ or 4 pounds, are occasionally taken. The average length of the market catch is about 12 inches. Such a fish weighs from three-fourths of a pound to a pound.

Small mackerel are known among the fishermen by several names, such as "spikes," "blinkers," and "tinkers." Spikes are the smallest caught by the commercial fishermen; they are 5 or 6 inches long and are 5 to 7 months old. Tinkers are under 9 inches in length and are supposed to be about two years old. Blinkers are intermediate in size and age. Maturity is probably attained in the fourth year.

DISTRIBUTION, MOVEMENTS, ABUNDANCE, AND SPAWNING.

This species inhabits the North Atlantic Ocean. On the American coast its range is from Cape Hatteras to the Straits of Belle Isle. On the European coast the fish is found from northern Norway, in latitude

71°, to the Mediterranean and Adriatic. It is not recorded from the West Indies, Bermudas, Gulf of Mexico, South America, or Africa.

On the east coast of North America mackerel first appear in the spring off Cape Hatteras and subsequently reach the shores of the Middle and New England States and the British possessions, migrating in from the sea from a southerly or southeasterly direction. Certain bodies of fish seek the New England shore, while others first strike the shore of Nova Scotia and follow it into the Gulf of St. Lawrence. They leave the coast in the same way in fall and early winter.

The mackerel is a wandering fish. Its movements when in the coast waters are undoubtedly regulated by external causes not yet clearly understood, but food, temperature of water, and reproduction are potent factors.

The mackerel is one of the most abundant fishes found on the Atlantic coast. It goes in schools, often of immense extent. The testimony of reliable fishermen relative to the size of schools observed often seems incredible; thus one school seen in the South Channel in 1848 was half a mile wide and at least 20 miles long. Another school noticed off Block Island in 1877 was estimated to contain 1,000,000 barrels. The schools swim at the surface or at varying depths beneath the surface, and present a comparatively broad front.

From the earliest times, there have been periods of scarcity of mackerel alternating with seasons of abundance. As early as 1670 the Colony of Massachusetts enacted laws for the preservation of mackerel. Since 1885 there has been the most noteworthy and prolonged scarcity of the fish of which there is any record. The New England catch in 1885 was 330,000 barrels, and in the 8 years ending in 1885 averaged 309,000 barrels; in 1886 it fell to 80,000 barrels, and in the succeeding 10 years aggregated only 481,000 barrels; was several times below 25,000 barrels, and never exceeded 89,000 barrels. The yield in 1896 was the largest in 9 years.

The spawning season on the east coast of North America includes the months of May, June, and July, June probably being the principal month. The spawning-grounds are in rather deep water and extend along the entire coast from Long Island to the Gulf of St. Lawrence. Most of the bays and sounds of the New England coast are important spawning-grounds, as is also the Gulf of St. Lawrence. Prior to spawning and for several weeks thereafter the mackerel are lean and poor and never make No. 1 fish when salted.

FOOD AND ENEMIES.

The mackerel feeds on a large variety of small animals, and is in turn eaten by a number of fishes, birds, cetaceans, etc. The relations existing between the presence of favorite food and of enemies on one hand and of mackerel on the other are fully appreciated by the commercial fishermen, who are often guided in their search for fish by the appearance of mackerel food in abundance or of their well-known

enemies. The presence of food is frequently shown by flocks of birds, especially phalaropes, which are called "mackerel geese."

The principal food objects of the mackerel are small crustaceans; copepods predominate, but shrimps of various kinds, young crabs, etc., are also important. One of the surface-swimming copepods, known as "red feed," "cayenne," etc., is a very favorite food; when mackerel have been feeding freely on it, they spoil very quickly after being caught, owing to their sides rotting or "burning." Fish constitute a rather important part of the mackerel's diet; herring, anchovy, sand lance, silversides, menhaden, and many other small fishes are eaten.

Among fishes, sharks are, perhaps, the most destructive enemies; mackerel sharks and dogfish are known to prey on the mackerel, driving and scattering the schools. Other fish enemies are bluefish and cod. Porpoises and whales are often seen feeding on the mackerel schools. Large squids do great damage to small mackerel. Among birds, the gannet is especially destructive.

THE MACKEREL FISHERY.

The mackerel is one of the best and most valuable food-fishes of the Atlantic Ocean. It is the object of important fisheries in Norway, Ireland, and Great Britain, and is extensively taken in the United States and the British provinces of North America. The fishery is prosecuted with vessels using purse seines, gill nets, and lines, much the largest part of the catch being taken in seines. In the boat fishery, lines and nets are employed. Stationary appliances, such as pound nets, trap nets, and weirs, also secure considerable quantities of mackerel.

In the United States the vessel fishery is carried on chiefly from Gloucester, Mass. The vessels sail south in early spring and fall in with the fish when they first appear off the coast of the Southern and Middle States, the catch being landed fresh in New York and Philadelphia. The fleet next seeks the fish on the southern shore of Nova Scotia and follows the school north to the Gulf of St. Lawrence. During the summer some of the vessels enter the gulf, but most of them cruise on the New England shore, where most of the fall fishing is also done. Some of the finest fishing vessels of the United States are engaged in this fishery. In recent years the fleet has numbered only 150 to 225 sail, but formerly nearly 1,000 vessels were at times employed in this branch.

The shore and boat fishing is carried on from New Jersey to Maine. The fish thus caught are as a rule sold in a fresh condition.

The fishery is much less productive than formerly, and during the past ten years has not as a rule been profitable, although each year a few vessels make good catches and yield very satisfactory returns, owing to the high price of fish. The local fishing does not supply the home demand, and large quantities of fresh and salt mackerel are annually imported from Norway, Ireland, and the British provinces.

ARTIFICIAL PROPAGATION.

The artificial propagation of mackerel was more extensively prosecuted in 1896 than in any previous year. The long-continued scarcity of mackerel on the Atlantic coast of the United States seemed to warrant some efforts on the part of the Government to increase the supply by artificial means. The limitations of mackerel culture depend on the erratic movements of the fish in a given season or on a given part of the coast and the difficulty of securing healthy eggs in large quantities from fish taken by the commercial fishermen. During the summer of 1896, 24,000,000 mackerel eggs were collected. The work was largely experimental and only a small percentage of fry was hatched, but the outlook is good for a great expansion of mackerel propagation.

The egg of the mackerel is one of the smallest dealt with by the fish-culturist, being only $\frac{1}{10}$ inch in diameter. Being provided with a large oil-globule, it floats at the surface, like the eggs of many other marine fishes. Within 48 hours after fertilization it generally begins to sink, remains in suspension a short while, and then falls to the bottom, where it remains until hatching ensues.

Owing to the inability to retain mackerel in ponds or live-cars pending the ripening of the eggs, as is done with the cod, it is necessary to depend for the egg supply on the nets of the fishermen. The eggs collected at Woods Hole are secured from fish captured in pound nets near Chatham and at other points on the southern Massachusetts coast; at Gloucester traps in the vicinity furnish the eggs. As the nets are usually hauled only once or twice a day, the fish have often been caught for many hours, and the tender eggs have undergone considerable loss of vitality; the quality of the eggs seems to have a direct relation to the length of time the fish have been in the nets.

One of the most favorable grounds for collecting mackerel spawn is Casco Bay, on the coast of Maine. Mackerel are taken chiefly in drag nets set about 4 o'clock p. m., and hauled from 9 o'clock p. m. to daylight. Eggs from fish caught in the first hauls of the nets are of much better quality than those taken in the last lifts.

In collecting eggs from pound nets the spawn-takers accompany the fishermen when they visit their nets and overhaul the mackerel as they are taken into the boats. The collection of eggs from the drag-net fishermen requires the spawn-takers to remain on the fishing-grounds from early in the afternoon until the next morning.

There is nothing peculiar in the methods of stripping the fish, mixing the eggs and milt, and transferring the eggs from the field to the hatchery. Although both the wet and the dry methods of fertilization have been practiced, the latter apparently gives better results. The average number of eggs taken from a fish is probably about 40,000. Three mackerel, stripped at Woods Hole in 1893, yielded 434,500 ripe eggs, an average of 144,833 eggs. As many as 546,000 eggs have been taken from a $1\frac{1}{2}$ -pound fish, and the largest fish probably yield fully 1,000,000

eggs. The largest number of eggs taken from one fish in Casco Bay in 1897 was 200,000.

From the field the fertilized eggs are conveyed to the station in jars, as described in the chapter on cod propagation. For short shipments they may be transported in buckets or cans.

Mackerel eggs may be artificially incubated in a variety of ways. In 1896 three forms of apparatus were employed for comparative purposes. These were (1) the McDonald hatching-jar, with the water supplied through the long central tube and discharged through a cheese-cloth top; (2) the Chester jar, and (3) the automatic tidal-box; the latter gave the best results.

Owing to the very small size of the eggs, from 200,000 to 225,000 may be placed in a Chester jar and 450,000 or more in a tidal box 20 by 11 inches. The eggs are manipulated in about the same way that cod eggs are, but, owing to the short period of incubation, require very little handling.

For reasons not yet definitely determined, but apparently connected with the condition of the eggs rather than the methods of hatching, mackerel ova are liable to exceedingly large mortality during incubation. While as many as 75 per cent of certain small lots of eggs have produced fry, less than 1 per cent of most of the eggs hatch.

The period of incubation at a mean water-temperature of 58° is about 5 days. In 48 hours after impregnation the embryo is discernible, and in 68 hours its development is far advanced. The critical period seems to be the end of the third day, when a large part of the eggs die.

The fry are planted within 24 hours of hatching. They are taken to the natural spawning-grounds in regular transportation cans and liberated below the surface of the water.

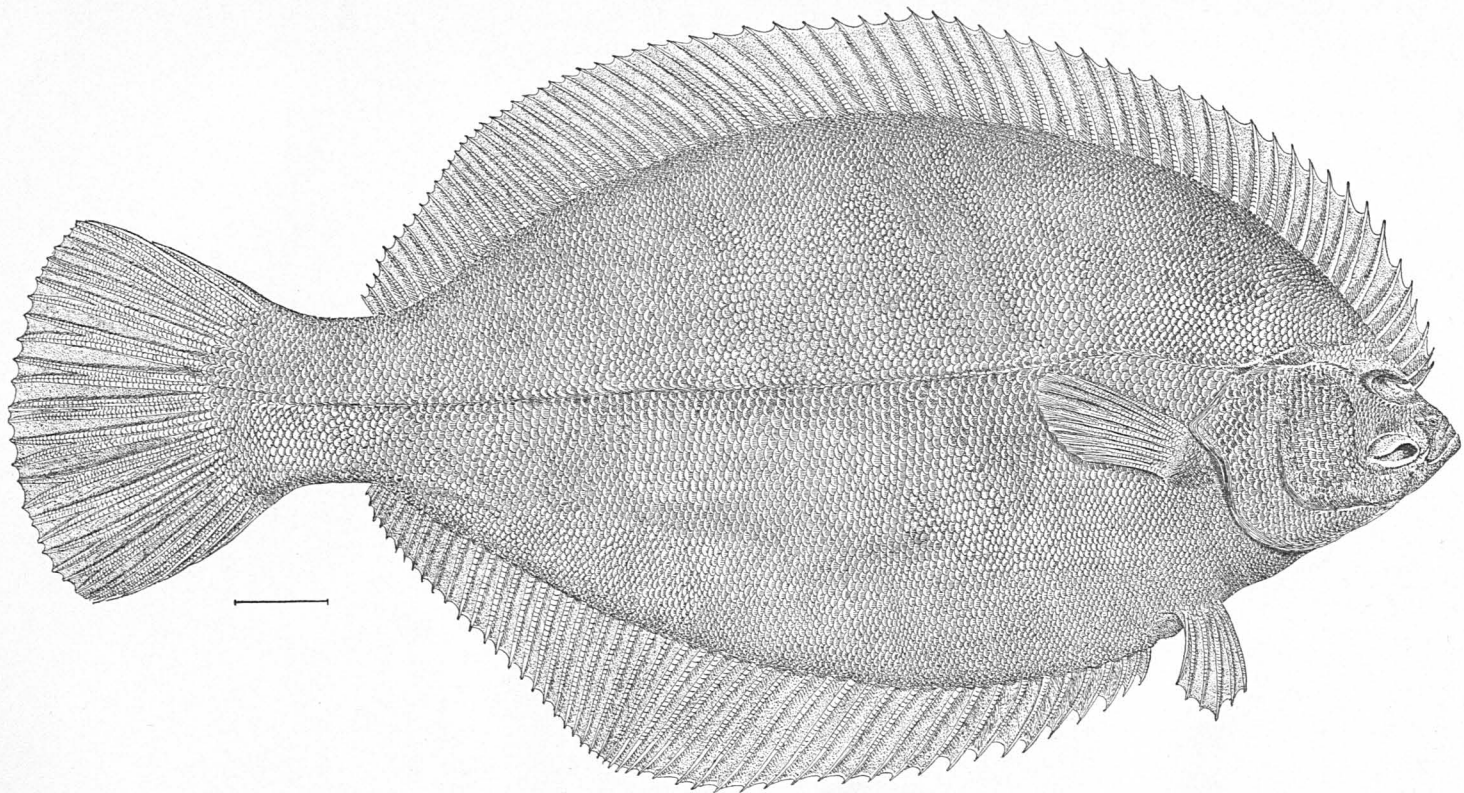

PSEUDOPLEURONECTES AMERICANUS. *Flatfish, or Winter Flounder.*

THE FLATFISH, OR WINTER FLOUNDER.

The body of the flatfish (*Pseudopleuronectes americanus*) is regularly elliptical. The eyes and color are on the right side. The upper side of the head is covered with imbricated ctenoid scales similar to those of the body; the blind side of the head is nearly naked. The teeth are close-set, incisor-like, and form a continuous cutting edge; the right side of each jaw is toothless. The length of the head is contained 4 times in the length of the body and the depth $2\frac{1}{4}$ times in the body length. The dorsal fin contains 65 rays and the anal fin 48 rays. The lateral line, which is nearly straight, has 83 scales. The color above is dark rusty-brown, either plain or mottled with darker; the young are olive-brown, spotted with reddish; the under parts are white.

This species has a comparatively small mouth, and feeds chiefly on small shells, crabs, and other bottom animals. It is found on sandy, muddy, or rocky bottoms, and seems to prefer sheltered coves and bays. Its coastwise and bathic movements are limited. It is one of the most abundant flounders of the Atlantic coast, being especially numerous in southern New England and New York. It ranges as far north as Labrador and as far south as the Carolinas, but is not present in noteworthy quantities south of New Jersey. It does not attain a large size, the usual length being only 12 to 15 inches and the weight about $1\frac{1}{2}$ pounds. Very rarely examples are taken over 20 inches long, weighing as much as 5 pounds.

The winter flounder is exceedingly prolific, over a million eggs being laid by a large fish. Along the coast of the southern New England and Middle Atlantic States the spawning season is from February to April. By August the young fish, having attained a length of 1 or 2 inches, are found in shallow water along sandy shores. The species is obtained principally during the winter and spring months, and large quantities are sent to the markets, where it sells readily at good prices. The flesh is white, firm, and of excellent flavor. Next to the halibut and the summer flounder, or plaice (*Paralichthys dentatus*), this is the most important flatfish of the Atlantic coast.

The winter flounder has been more extensively propagated than any other species of *Pleuronectida*, owing to the facility with which its eggs are obtained at Woods Hole, where its propagation fills in the time between the taking of cod eggs on one hand and of lobster eggs on the other, slightly overlapping the ending of the former and the beginning of the latter. The work covers that part of the year when the most

inclement and changeable weather occurs, and is necessarily somewhat limited in extent by uncontrollable physical and other conditions.

During the fiscal year 1895-96, the collections of flatfish eggs numbered 11,008,000, which yielded 8,472,000 fry; in the year 1896-97 84,591,000 eggs were taken, from which 64,095,000 fry were hatched.

The flatfish from which eggs are obtained are very plentiful during February in the Woods Hole region, being found on sandy or hard clay bottom, and taken in fyke nets set in water from 6 to 14 feet deep. As many as 60 to 70 fish are sometimes taken at one lift of a fyke net, but as a rule not more than two or three of this number are gravid fish. These nets are usually some distance from the station, and the fish are carried to the hatchery in transportation cans, six or eight being put in one can. In some cases this trip is made by water in a sail or row boat, while at other times it is made overland by team. The fish are often carried 10 or 12 miles without change of water and without apparent injury. A few are caught while the water temperature is as low as 33° F., but they are more numerous after the temperature reaches 34° or 35° F. On arriving at the station the fish are put into wooden tanks supplied with constantly changing water, and here they are held until ripe. It is customary to put both males and females in the same box or tank. The fish are examined daily and the eggs are taken from all which are found to have ripened, the stripped or spent fish being released.

The eggs of the flatfish are quite small, there being 30 in a linear inch. Unlike the eggs of the cod, haddock, mackerel, and other marine fishes, they do not float, but sink to the bottom of the vessel in which they are held. They are not so heavy as those of the lobster, and a slight current causes them to rise and carries them to a point where there is still water, when they again go to the bottom. When first deposited, the eggs are very adhesive and stick together in one mass or in clusters of different sizes. This adhesiveness is overcome, in a measure, by thoroughly washing them, and, as this force gradually weakens as the eggs become older, usually nearly all the eggs are separate when they begin to hatch. The use of dry powdered starch is very effective for this purpose; this mixes readily with the salt water and admirably overcomes the glutinosity of the eggs. Its action is purely mechanical.

In stripping, it is customary to fill a Chester jar with water and place inside the jar a bag made of cheese-cloth, into which the eggs are allowed to fall. The fish is grasped by the head with the left hand, the mouth being in the palm of the hand, and the edge on which the vent is located turned from the spawn-taker. The right grasps the fish near the tail, and as it is moved with gentle pressure toward the vent, at the same time that the left thumb is moving crosswise and exerting similar pressure, the eggs are extruded. The milt is then expressed in the same way; the eggs are stirred slightly with the hand to thoroughly mix them with the milt, and after allowing a short time for the action

of the milt they are cleaned and the superfluous milt washed off by introducing a gentle stream of water into the bag and rolling the eggs from side to side.

It frequently happens that fish held in tanks to mature deposit their eggs during the night. In such cases the eggs are found on the bottom of the tank the next morning. They are usually in clusters and when examined with the microscope it will be found that practically every egg is fertilized.

After the eggs have been taken and fertilized the number is calculated by measuring in a glass graduate and computing 47,826 eggs to the liquid ounce. The average number of eggs is about 500,000 to a fish. On March 6, 1897, 30 ounces, or 1,462,000 eggs, were taken from a fish 20 inches long and 11 inches wide, its weight being 3½ pounds after the eggs were taken.

Flatfish eggs may be hatched in several kinds of apparatus, but the Chester jar is most used, in combination with the McDonald tidal box employed in incubating cod eggs. From 400,000 to 500,000 eggs are usually placed in each jar. The top of the jar is covered with cheese-cloth held in place by rubber bands. The jar is then inverted and placed in a tidal box. The usual complement of each box is 2 jars. A wooden frame of 1-inch strips is placed lengthwise on the bottom of the box for the jars to rest on, so as to raise them and allow the free circulation of the water. A hole in the bottom of the jar allows the air to pass in and out as the water inside rises and falls. The inner compartment, with a bottom of cheese-cloth, used in cod-hatching is omitted.

As in using the jars the eggs are generally on the bottom all the time, the experiment has been tried of employing the McDonald box with the automatic current in order to keep the eggs in circulation. It having been found that the current commonly used for cod eggs caused the eggs to pile up in the end nearest the outlet, a stream was introduced into each end of the box and the water was allowed to escape in all directions through a perforated nozzle; the water was kept about 3 inches deep in the bottom of the box by using a quantity sufficient to prevent the breaking of the siphon. By this means a constant current is formed, the eggs develop nicely, and the fry hatch, but the current necessary to keep the eggs in circulation is strong enough to kill the fry by forcing them against the sides of the box. This experiment is therefore not considered a success.

The period of incubation when the mean water temperature is 37° or 38° F. is 17 or 18 days.

The fry of the flatfish, although much smaller than those of the cod, are much more lively, and are straightened out when first hatched. Unlike the young cod, they do not float on the surface, but are scattered through the water from top to bottom, many being seen among the eggs on the bottom of the jars. Unlike the adults, the flatfish fry

swim with the body upright, as young fish of other families do, and when first hatched the eyes are on opposite sides of the head. At the age of about three months, however, one of the eyes will have moved to the other side of the head, to conform with the change of the body in swimming from an upright to a flat position. The position constantly assumed by the very young fry is peculiar, the long axis of the body being vertical, with the head upward. This is owing to a large oil-globule in the anterior part of the yolk-sac.

The fry are quite hardy and stand transportation very well. They have been kept three weeks without change of water in a bottle hanging in a box of running water to maintain an even temperature in the bottle. In planting the fry, which is done in one or two days after hatching, they are put into the transportation cans commonly used for such purposes and taken in a boat to localities in which the brood fish are found. The cans are put overboard and sunk until the mouth is submerged, when the contents are gently turned out. For a trip of not more than two or three hours' duration, with water temperature about 38° F., from 400,000 to 500,000 fry may be safely carried in a 10-gallon can.

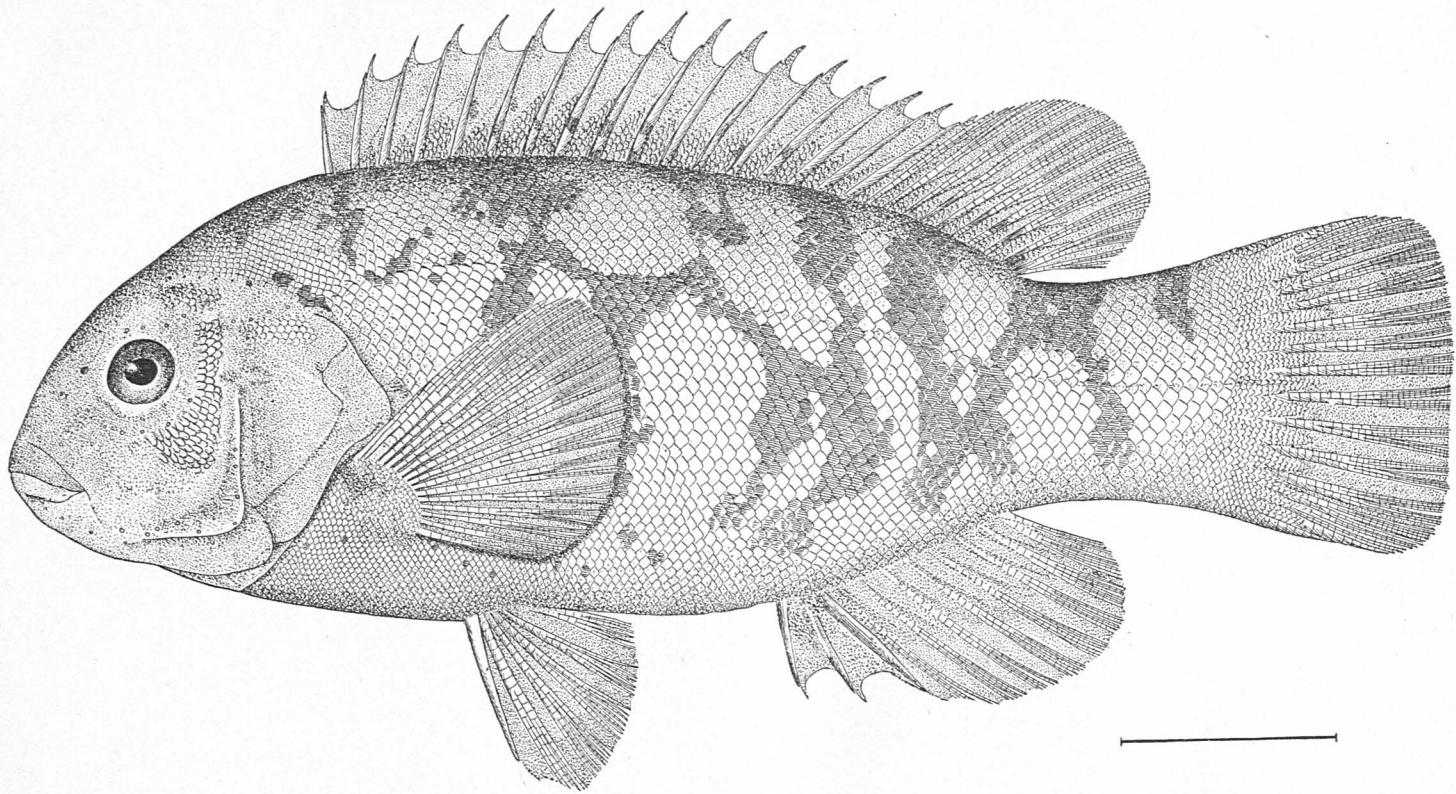

TAUTOGA ONITIS. *Tautog.*

MISCELLANEOUS MARINE FISHES.

In addition to the salt-water fishes previously considered, a number of others have been artificially propagated by the U. S. Fish Commission. With some of these the fish-cultural work has been rather extensive; with others, hardly more than experimental. Among those to which most attention has been given are tautog, Spanish mackerel, pollock, and haddock. Others that have come in for a share of either practical or experimental work are sea herring, scup, sea bass, squeteague, cunner, sheepshead, and several flounders.

The same methods of culture mentioned hereafter in connection with tautog are applicable in general to scup, sea bass, squeteague, and other species having floating eggs.

THE TAUTOG.

The tautog (*Tautoga onitis*) is a strongly marked species. It belongs to a family (*Labridæ*, or the wrasses) characterized in part by one dorsal fin, thoracic ventral fins, double nostrils, thick lips, and strong teeth in the jaws. The tautog has an elongated body and a large head with a convex profile. The rather small mouth is armed with strong conical teeth in two series. The eye is small and placed high on the side of the head. The body is covered with small scales, in about 60 transverse rows and 40 longitudinal series. The head is destitute of scales, with the exception of a small patch behind the eye. The dorsal fin is long and low, with 16 strong spines and 10 soft rays. The anal fin contains 3 spines and 8 rays. The body length is $3\frac{1}{4}$ or $3\frac{1}{2}$ times that of head and $2\frac{2}{3}$ or 3 times the depth. The gillrakers are short, feeble, and number only 9. The color of adults is almost uniformly blackish or greenish; the young are marked by dark irregular crossbars on a pale brownish background; chin, white; iris, bright green.

The tautog is of considerable importance in certain parts of its range. It is found from Maine to South Carolina, but is most abundant in Massachusetts, Rhode Island, and New York. It is one of the best-known shore fishes of the east coast, and goes by a variety of names, among which are blackfish, chub, oyster-fish, and moll, besides the most generally used name of tautog.

The tautog inhabits principally rocky bottom, where it hides in crevices, often with its body in an apparently very unnatural position. It is quite susceptible to changes in temperature, and during winter enters into a state of hibernation in the more northern parts of its range. Its coastwise movements are very limited. Its sharp strong teeth enable it to consume mollusks and crustaceans, which are its chief food; it also eats sand-dollars, worms, and other animals.

The tautog is taken for market in considerable numbers by means of lines and traps. It bites quite readily and is a favorite with anglers. Its average weight as caught for sale is not more than 2 or 3 pounds, but tautog weighing from 6 to 15 pounds are not rare. The maximum weight is about $22\frac{1}{2}$ pounds; such a specimen from New York, $36\frac{1}{2}$ inches long, is preserved in the U. S. National Museum. The annual commercial catch of tautog is about 1,500,000 pounds, valued at \$60,000; nearly half the yield is from Massachusetts.

The spawning season on the southern New England coast extends from April to August, although June appears to be the principal month. The young are very abundant along the shores in the fall.

The artificial propagation of tautog was experimentally undertaken at Woods Hole in 1886. In 1896, 31,431,000 eggs were taken in June; from these 17,575,000 fry were hatched and planted in neighboring waters.

Tautog from which eggs for hatching are taken are obtained from nets or from line fishermen near the station and transferred to live-cars. When first brought in they seldom yield any eggs, but in 2 to 6 hours they may be stripped of a part of their eggs. The eggs taken after fish are held more than 6 hours are usually of no value, and those obtained from fish retained one night are invariably worthless.

The tautog is very prolific. In 1896 a $9\frac{3}{4}$ -pound fish yielded 1,142,600 eggs, and it was estimated that the ovaries contained fully as many more eggs that were not yet mature. The average number of eggs per fish is from 150,000 to 200,000.

The eggs of the tautog are about $\frac{1}{16}$ inch in diameter. They are buoyant, like those of the mackerel, and are susceptible of the same method of hatching. When placed in the automatic tidal box, they hatch in about 5 days, with the water temperature at 69° F., and in 2 or 3 days with the temperature at 71° .

The newly hatched fry are transparent and exceedingly small, the length being only $\frac{1}{12}$ inch. They are quite hardy and stand transportation well. They are planted shortly after hatching.

THE SPANISH MACKEREL.

The Spanish mackerel (*Scomberomorus maculatus*) is the best-known fish of the genus and the only one that has received the attention of fish-culturists. From the other species of *Scomberomorus* found on the eastern United States coast (*S. regalis*, the kingfish, and *S. cavalla*, the cero) this fish is, in part, distinguished by its smaller size and by the insertion of the soft dorsal fin in advance of the anal. The body is long, the head small and pointed, the mouth large and armed with prominent teeth. The anterior dorsal fin has 17 spines, the soft dorsal has 18 rays. The anal fin has 2 spines and 17 rays. Behind both the dorsal and anal fins are 9 small finlets. The lateral line is wavy and has about 175 pores. The general color is silvery, dark-bluish above and whitish below. The sides have numerous rounded yellowish spots.

This fish is widely distributed, being found on both coasts of North America. On the west coast it does not enter United States waters, but on the Atlantic seaboard it ranges from Texas to Massachusetts. It is especially abundant in the Gulf of Mexico, among the Florida keys, in Chesapeake Bay, and on the coast of the Middle Atlantic States.

Its maximum weight is about 9 pounds. Many weighing only 1 or 1½ pounds are caught for market, and the average is less than 3 pounds.

The Spanish mackerel is one of the choicest food-fishes of American waters; in popular estimation it is scarcely surpassed by any marine species except the pompano. It is caught throughout its range on the east coast with gill nets, seines, pound nets, and lines. The principal fishing is on the west coast of Florida, on the Louisiana coast, in the lower part of Chesapeake Bay, and on the coasts of New Jersey and New York. The approximate annual value of the catch at present is \$130,000, which represents 1,700,000 pounds. In 1880 the output was 1,887,000 pounds, having a value of \$132,000. The yield in the Middle States is much less than formerly, while in the Gulf States it has increased.

The fish spawns throughout its entire range on the United States coast. The spawning season is quite prolonged, extending from April in the Carolinas to September in New York, and in a given locality continues from six to ten weeks. All of the eggs in the ovaries of a given fish do not mature at one time; eggs in all stages of development may be found, suggesting a comparatively long spawning season for individual fish as well as for the species as a whole. The eggs, when laid, float at the surface, where they are driven about by wind and tide. Doubtless a large percentage of the eggs do not hatch, through failure of fertilization and by being stranded. The eggs are very small, their diameter being only $\frac{1}{8}$ to $\frac{1}{2}$ of an inch.

The artificial impregnation and hatching of Spanish mackerel eggs were first accomplished in 1880, since which time the propagation of the fish has been taken up on a number of occasions, although the work in any one season has been comparatively limited.

The serious diminution in the supply of this species in certain sections seems to call for its artificial cultivation whenever it can be taken up without detriment to the propagation of other more or equally important fish.

In the work of artificially propagating this fish recourse has been had to the nets of commercial fishermen for the supply of spawn and milt. Chesapeake Bay has been the seat of the principal operations, which have been conducted by the steamer *Fish Hawk*. The catch of Spanish mackerel in this bay in pound nets and other appliances is very large, and the facilities for fish-cultural work of this character are doubtless superior to those of any other section, with the possible exception of the west coast of Florida.

The necessity for depending on the fishermen for the supply of eggs is somewhat detrimental to the best results and prevents extensive work, although the owners of fishing apparatus heartily cooperate.

Owing to the fact that the fish appear to spawn mostly at night, when the pound nets are lifted in the morning the ripe eggs have in many cases been extruded before the spawn-taker could secure them. The injuries which the fish sustain while in the pound nets and during the hauling of the nets appear to seriously affect the eggs and cause the non-hatching of a comparatively large percentage. Undoubtedly better results may be obtained if a number of nets are fished exclusively for this purpose, insuring the careful removal of fish at the best times for taking and fertilizing the eggs.

The eggs are very delicate and susceptible to meteorological influences. Their development is markedly affected by water temperature and atmospheric conditions; electrical disturbances, as with other fish eggs, are injurious, but to what extent and in what way are not known. The largest number of ripe eggs thus far taken from a single specimen is 60,000, but the average is only 20,000.

The Chester jar, such as is used in hatching flatfish eggs, has been found the best apparatus for Spanish mackerel eggs. If the jars are kept clean and not overcrowded, a constant current of water does not seem to be essential; of a lot of 60,000 eggs in a jar of quiet water, 90 per cent hatched. The cod tidal-box is also adapted to this work.

In ordinary bay water having a density of 1.014 to 1.019, the eggs are buoyant and remain at the surface until hatching ensues; but in water of low specific gravity they sink and give unsatisfactory results. The period of incubation is very short. Under normal conditions eggs hatch in 20 to 30 hours, averaging 25 hours, at a temperature of 77° or 78°. The fry are planted soon after hatching.

HADDOCK, POLLOCK, AND OTHER GADIDÆ.

The methods of culture employed with the cod are applicable to other members of the cod family having buoyant eggs. The United States Fish Commission have frequently taken and hatched eggs of the pollock (*Pollachius virens*) and the haddock (*Melanogrammus aeglefinus*). Both are important food-fishes, but much less valuable than the cod, and the collection of eggs has generally been only supplemental to cod work.

The pollock is found from New Jersey northward. It goes in large schools, which are often found at the surface, thus differing from the cod and haddock. The average weight is 9 or 10 pounds, and the maximum about 30 pounds. Fishing is chiefly done from small vessels and boats, and is most important in Massachusetts. The value of the annual catch is about \$100,000. The pollock is an excellent food-fish in both a fresh and a salted condition.

The eggs of the pollock have at times been gathered in large numbers in the vicinity of Gloucester; during some seasons about 40,000,000 eggs have been taken. The eggs measure about $\frac{1}{2}$ inch in diameter. The pollock spawning season includes the months of October, November, and December. The fish from which eggs are obtained are taken

with nets and lines by commercial fishermen; the average number of eggs to a fish is from 200,000 to 250,000. The period of incubation is somewhat shorter than that of the cod, being 9 days at 43° and 6 days at 49°. About 5 days are required for the absorption of the yolk-sac.

The haddock ranges from Delaware northward, and is, as a rule, very abundant on the "banks" lying off the New England shore. In its habits it is similar to the cod, frequenting the same grounds and being caught at the same time. Its average weight is about 4 pounds and the maximum under 20 pounds. The fishery is very extensive in Massachusetts, most of the catch being landed fresh in Boston. The annual yield is about 50,000,000 pounds, worth \$1,115,000.

The artificial propagation of haddock has been conducted chiefly at Gloucester, where as many as 30,000,000 eggs have been collected in a single season. The eggs are about $\frac{1}{17}$ inch in diameter, and are quite delicate and tender. The spawning time extends from January to June. The average production of eggs per fish is about 100,000.

The eggs are slightly glutinous and have a tendency to form into small lumps during hatching. At a mean temperature of 37° they hatch in 15 days, and at 41° in 13 days. The yolk-sac is absorbed in 10 days at a temperature of 41°.

The tomcod or frostfish (*Microgadus tomcod*) has been extensively propagated by the New York Fish Commission. It is a small but excellent food-fish, found along the Atlantic coast from New York to the Bay of Fundy. It is most abundant in early winter, when it approaches the shores and ascends streams for the purpose of spawning. It rarely exceeds 10 or 12 inches in length.

THE CUNNER.

The eggs of the cunner or chogset (*Ctenolabrus adspersus*) are of the same size and character as those of its near relation, the tautog, and are deposited during the same season. In water having a mean temperature of 56° F. they have been hatched in 5 days, in the tidal cod-jar. On account of the small size, great abundance, and comparatively little commercial value, the propagation of the cunner has not been regularly undertaken.

THE SCUP.

The scup (*Stenotomus chrysops*) is a rather important small food-fish found along the Atlantic coast from Cape Ann to South Carolina; it is most abundant in southern New England. It spawns in June. The eggs are $\frac{1}{28}$ inch in diameter and hatch in 4 days at a mean temperature of 62° F.

THE SEA BASS.

The eggs of the sea bass (*Centropristes striatus*) are of the same size as scup eggs, are deposited in June, and hatch in 5 days with the water temperature 59° or 60°. The sea bass is an important food-fish,

found from Massachusetts to Florida; it is taken in large quantities from New Jersey northward with lines and traps. It attains a weight of 5 pounds, but the average weight is only 1 or $1\frac{1}{2}$ pounds.

THE SQUETEAGUES.

The squeteague or weakfish (*Cynoscion regalis*) is a prominent food-fish of the Atlantic and Gulf coasts, the northern limit of its range being in the vicinity of Cape Cod. It goes in immense schools and is taken in large quantities for market, in North Carolina, Chesapeake Bay, Delaware Bay, on the New Jersey and New York coasts, and in southern New England. It varies greatly in size; the average weight is under 5 pounds, but it has been known to attain a weight of 30 pounds. In the vicinity of Woods Hole this fish spawns in June. Its eggs are $\frac{1}{8}$ inch in diameter, and at an average temperature of 60° F. hatch in 2 days.

The spotted squeteague or "sea trout" (*Cynoscion nebulosum*) has also been propagated on a small scale. It is a valuable food-fish from Chesapeake Bay southward, being taken in largest quantities in Virginia, North Carolina, Florida, and the Gulf States. Its average weight is 2 pounds and its maximum 10 pounds. It spawns in bays and sounds in spring and summer, the time varying with the latitude. The eggs are buoyant, $\frac{1}{3}$ inch in diameter, and hatch in about 40 hours at a temperature of 77° F. This species has been artificially hatched on the southwest coast of Florida by the steamer *Fish Hawk*.

THE SHEEPSHEAD.

The sheepshead (*Archosargus probatocephalus*) is generally regarded as one of the best food fishes of American waters. Its deep body, of a grayish color, marked by 8 transverse black bands, and its peculiarly shaped head, with mouth armed with prominent incisor teeth, make it readily recognized. It ranges from Cape Cod to Texas, but is most abundant from Chesapeake Bay southward. It attains a weight of over 20 pounds, but the average weight on the Atlantic coast is not over 7 or 8 pounds, and in the Gulf of Mexico scarcely exceeds 3 pounds. In southern waters the fish is a permanent resident, but in the northern part of its range it is found only during spring, summer, and autumn. The spawning season is from March to June, according to the locality.

The artificial hatching of the sheepshead has been undertaken on several occasions, but is not regularly prosecuted. The most extensive work was conducted by the *Fish Hawk* in March and April, 1889, when 23,400,000 eggs were taken in the vicinity of San Carlos Bay, on the southwest coast of Florida. These yielded 16,500,000 healthy fry, most of which were planted in local waters.

In capturing spawning fish on the Florida coast it was found that the best time to use the seine was just before sundown, as the flood tide was about to "make." The fish were then easily taken in large numbers. Seine hauls in the morning consisted only of male fish. Spawning

sheepshead swim in schools, and seem to prefer sandy beaches, along which they resort at a depth of 6 or 8 feet.

The sheepshead egg is very small, transparent, and of less specific gravity than sea water. The diameter is $\frac{1}{32}$ of an inch, and the number in a fluid ounce is about 50,000, or 1,600,000 in a quart.

The eggs are satisfactorily incubated in the tidal cod-jar, about 300,000 eggs being placed in each jar. The development is very rapid, and in the warm water of the Gulf (76° or 77° F.) the eggs hatch in 40 hours. The newly hatched fry are very small, but active and strong, and withstand considerable rough handling. They are planted when 72 to 80 hours old.

It is probably not practicable to carry on extensive sheepshead hatching north of Florida, although small quantities of eggs could doubtless be taken in North Carolina and Virginia.

THE SEA HERRING.

The sea herring (*Clupea harengus*) may be distinguished from other clupeoid fishes found in United States waters by the following characters: Body elongate and laterally compressed, the depth contained $4\frac{1}{2}$ times in length; mouth at end of snout; lower jaw projecting, extending to beneath the middle of eye; roof of mouth with an ovate patch of small teeth; gillrakers long and slender, about 40 below the angle in adults, fewer in young; dorsal fin with 18 rays, inserted slightly behind middle of body; ventral fins beginning beneath middle of dorsal; anal fin with 17 rays; median line of belly with 28 weak spines or scutes in front of ventral fins and 13 behind fins; scales thin, easily detached, posterior edges rounded, 57 in lateral series; color bluish or bluish-green above, light-silvery below.

The sea herring exists in great abundance on both shores of the Atlantic Ocean north of the latitude of about 37° north. On the coast of North America it is not regularly abundant south of Cape Cod, but it is occasionally found as far south as Chesapeake Bay. In number of individuals this species is probably exceeded by no other fish. On the Pacific Coast a similar and almost equally abundant species (*Clupea pallasii*) is found from Alaska to Mexico.

There are no well-defined movements of the herring on the west shore of the Atlantic, if those induced by the spawning instinct are excepted. There was formerly a distinct shoreward migration, during the winter months, in the Bay of Fundy, but this run has not occurred for a number of years. In many places the herring, especially the smaller individuals, appear to be resident in the shore waters. The maximum length of this fish is about 17 inches, and the usual length of spawning fish on the United States coast is from 11 to 14 inches.

The herring subsists on minute invertebrates, chief among which are copepods, larval worms, and larval mollusks. In turn it is consumed in enormous quantities by cod, haddock, sharks, and many other fishes.

With respect to the time of spawning, the herring may be divided into two groups, one spawning in the spring, in April, May, and June, and the other between July and December. The spring spawning occurs entirely east of Eastport, Maine, and the fall spawning principally, but not altogether, west of that place. Probably the greatest spawning-grounds south of the Gulf of St. Lawrence are at Grand Manan, where the eggs are deposited principally in July, August, and September. Thence the season becomes progressively later westward, on the coast of Maine occurring between September 1 and October 15; on the eastern coast of Massachusetts, between October 1 and November 1, and south of Cape Cod from October 15 to December 1.

The female herring of average size deposits between 20,000 and 47,000 eggs at a spawning, the usual number being not far from 30,000. The eggs are deposited upon the bottom, and, being covered with a glutinous material which soon hardens in contact with the water, they become firmly attached to extraneous materials, to which they often adhere in masses as large as a walnut. The egg measures about $\frac{1}{10}$ inch in diameter, and is usually polyhedral from mutual pressure exerted by the eggs in masses.

The commercial value of the sea herring is almost incalculable. It is undoubtedly the most important of food-fishes, although in the United States it is exceeded in economic value by many marine and fresh-water species. Some time ago the annual yield of the world was estimated at 3,000,000,000 herring, weighing 1,500,000,000 pounds, the principal part of which was taken in Norway. In the New England States the annual catch is about 55,000,000 pounds, with a first value of \$350,000. The fish is taken chiefly with seines and weirs, and about five-sevenths of the yield is obtained on the coast of Maine. The market value of the output is greatly enhanced by the salting, smoking, and canning processes to which a large part of the catch is subjected. In Maine the canning of young herring as sardines is a very important industry. Fresh herring are used chiefly for bait in the line fisheries for cod and other "ground fish."

Experiments in the artificial propagation of the herring have been conducted both in this country and in Europe, but owing to the great abundance of the species the work has not been carried beyond this experimental stage. In the United States there has as yet been no permanent diminution of the supply that renders the cultivation of the species necessary, notwithstanding an extremely large fishery and the sacrifice of enormous quantities of very small fish.

The first successful attempt to propagate this fish was in 1878, in Germany, when elaborate experiments were made. In the same year the artificial hatching of the species was accomplished by the United States Fish Commission. The eggs, owing to their cohesion into masses, showed a tendency to molding, but this difficulty could doubtless be obviated by the use of starch, as with other cohesive eggs.

Development takes place in water ranging in temperature between 33° and 55° F., the time of incubation varying from about 40 days at the former temperature to 11 or 12 days at the latter. Sudden and extreme variation between the temperature limits mentioned had little or no effect except to retard or accelerate the hatching in accordance with the rule just mentioned. When water of a temperature lower than 33° F. was used many of the embryos were deformed. The degree of salinity of the water does not appear to exert much influence upon the hatching of the eggs.

THE SAND-DAB AND FOUR-SPOTTED FLOUNDER.

Besides the flatfish or winter flounder, two other flounders have been artificially hatched, on a small scale, at Woods Hole; these are the sand-dab (*Bothus maculatus*) and the four-spotted flounder (*Paralichthys oblongus*). The eggs of both fish are buoyant, and deposited in May. Those of the former are $\frac{1}{24}$ inch in diameter, and of the latter $\frac{1}{6}$ inch. The period of incubation at a temperature varying from 51° to 54° F. is about 8 days.

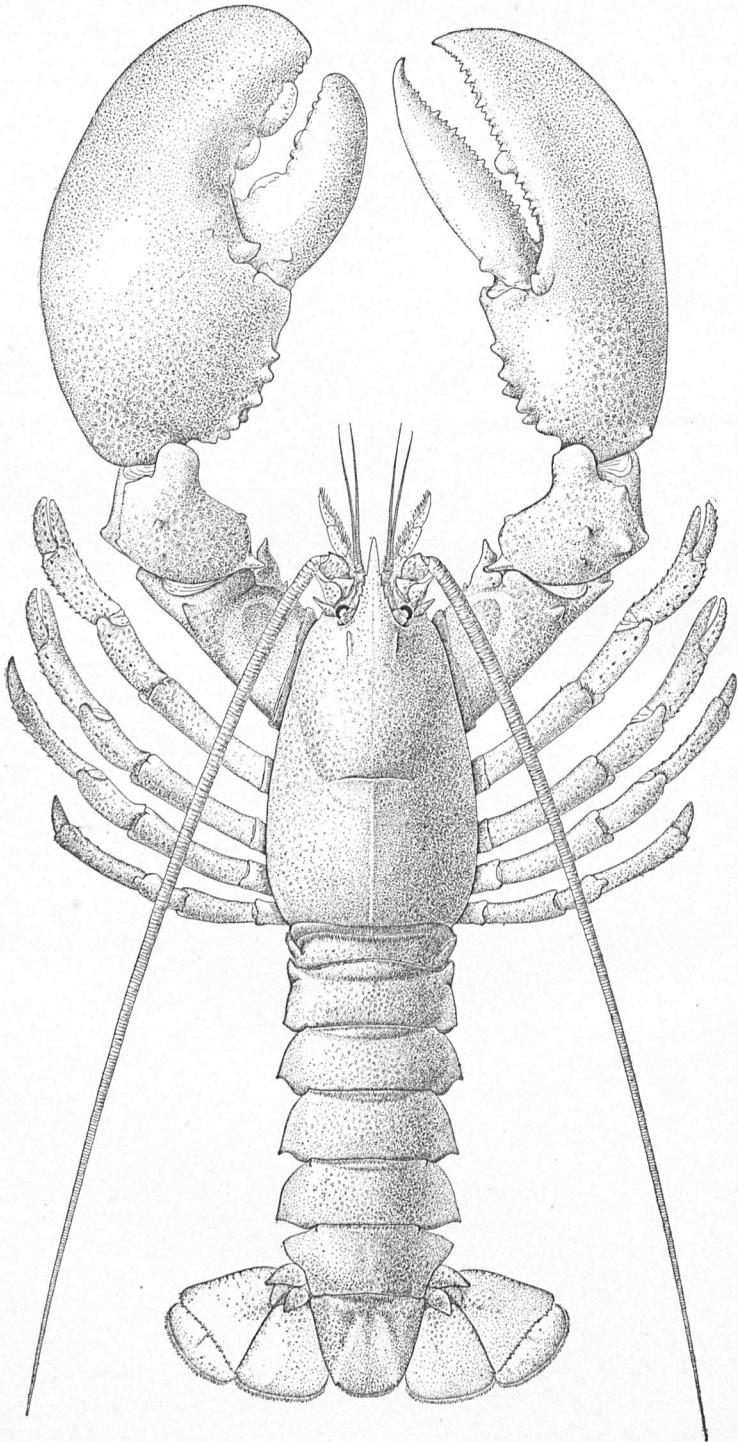

HOMARUS AMERICANUS. *American Lobster.*

THE AMERICAN LOBSTER.

DESCRIPTION.

The lobster (*Homarus americanus*) belongs to that group of the crustacea called the Decapoda, because all of its members are provided with ten feet, more or less adapted for walking. To the Decapoda also belong the crabs and the shrimps, prawns, and crayfish. The crabs are less related to the lobster than the other forms mentioned, and may be readily distinguished from them by the relatively great breadth of the body and the small size of the abdomen or tail, which is doubled under the thorax to form the "apron." The lobsters, crayfish, shrimps, etc., are elongate forms with the tail or abdomen very large and extended more or less in the same horizontal plane with the anterior part of the body. The lobster and the crayfishes are somewhat closely related, but differ, among other characters, in the number and structure of the gills and in the relative size of the flat plate or scale which is attached at the base of the antennæ or long feelers. The Pacific Coast crayfishes have 18 gills, those east of the Rocky Mountains have 17, while the lobster has 20. The appendage of the antenna is large in the crayfishes, but very small in the lobster. Moreover, the crayfishes rarely exceed 5 or 6 inches in length, while the adult lobster is much larger, as seen in the markets, seldom measuring less than 9 or 10 inches. The spiny lobster, the "lobster" of the Pacific Coast, is readily distinguished from the crayfish and the common lobster by the total absence of great claws, by the greater length and stoutness of the antennæ, and by the presence of large, broad-based, spinous processes on the back.

The body of the lobster is divided into two distinct regions, the cephalothorax and abdomen. The former consists of the head and thorax fused into one united whole. That portion which would constitute the head, were it separate, bears the eyes, the two pairs of feelers, and the mouth, with the several pairs of modified limbs which surround that organ and aid in tearing up the food and passing it between the lips. The thoracic portion of the cephalothorax is furnished with five pairs of stout limbs, the first pair bearing the great claws, which are rarely of the same size on the two sides, and the last four pairs being used in walking. From the fact that this portion of the body bears five pairs of appendages, it is assumed that it represents five fused segments.

The abdomen is narrower than the cephalothorax and is composed of six separate segments movable on one another. In the female the

first five pairs of abdominal appendages, known as swimmerets, are all similar and consist of a short basal piece and two terminal pieces side by side. The appendages of the sixth segment consist of the same arrangement of parts, but the pieces are broad and paddle-like, and, with the terminal plate attached to the last segment, constitute a powerful caudal paddle or tail. In the male the abdomen is narrower than in the female, and the first two pairs of swimmerets differ much from those which follow.

The color of the lobster is subject to great variation, but most frequently is dark bluish-green above, mottled with dark-green blotches; there is usually more or less red or vermilion on the appendages, especially on the tubercles, tips, and under side of the great claws and on the antennæ; the walking legs are light blue with reddish tips and tufts of hair. Occasionally specimens are found which are almost entirely red, and more frequently they are blue or bluish in general tone.

DISTRIBUTION AND ABUNDANCE.

The lobster is found from Labrador to Delaware, its range covering about 1,300 miles of coast line. Stragglers have been taken on the coasts of Virginia and North Carolina. While the bathic range is practically limited by the 100-fathom line, it is occasionally found long distances from land on the fishing-banks off the New England coast.

The lobster is most abundant in the northern part of its habitat. On the United States coast it is most numerous in Maine. In the provinces of Nova Scotia, New Brunswick, and Quebec, and also in Newfoundland it is extremely abundant.

MOVEMENTS.

The movements of the lobster are chiefly on and off shore. Such coastwise movements as characterize the mackerel, bluefish, and menhaden are never undertaken by the lobster. This fact makes possible the rapid depletion of fishing-grounds, and even the practical extermination of the lobster in given areas; it also affords basis for the belief in the efficacy of artificial means for maintaining and increasing the supply.

There are well-marked movements of the lobster induced by various influences, among which are the abundance or scarcity of food, the water temperature, and the spawning instinct. On the United States coast there is in the spring months a shoreward movement of large bodies of lobsters; on the approach of winter the lobsters move out into deep water.

FOOD.

The principal food of the lobster is fish, either dead or alive. Such bottom species as the sculpin, flounder, and sea-robin can doubtless be readily caught by the lobster, and they also consume a large number of invertebrates, among them being crabs and other crustaceans, clams, conchs, and other mollusks, starfish, sea-urchins, etc. Lobster eggs

have been found in a lobster's stomach, and algæ sometimes serve as food. Fish is the bait most extensively employed in the lobster fishery.

REPRODUCTION.

The reproductive function of the lobster is not generally understood, and until a comparatively recent date a number of important questions in relation thereto were undecided. From the standpoints of the commercial fishermen, fish-culturist, and legislator, it is necessary that the principal phases of this subject be clearly appreciated, in order that the supply may be maintained.

The principal spawning season for lobsters on the United States coast is summer, especially July and August, when probably three-fourths of the lobsters deposit their eggs. The remaining egg-producing lobsters lay during the fall and winter. A given lobster does not spawn oftener than every second year, as has been shown by recent studies conducted by the Commission.

The eggs are fertilized outside the body of the female. The spermatic fluid is deposited in a receptacle at the base of the third pair of walking legs, and retains its vitality for a long time. When the eggs are being extruded, the female lobster lies on her back and folds the tail so as to form a kind of chamber to retain the eggs. After their discharge from the body, the eggs become coated with a cement substance secreted by glands in the swimmerets; this substance hardens after being in contact with the water and firmly unites the eggs to the hair-like filaments on the swimmerets. The exact method by which the fertilizing principle is conveyed to the eggs from the pouch in which it is contained is not known.

The incubative period is much prolonged. After the eggs are extruded and become attached externally, they are carried 10 or 11 months before hatching ensues; during this time they are carefully protected, and are perfectly aerated by the active motion of the swimmerets. On the United States coast most of the lobsters emerge from the egg in June, although some of the hatching is completed in May and some in July or even later. A few eggs are now known to hatch in winter. All of the embryos do not come from the eggs at the same time, the hatching occupying a week or more. The young receive no attention from the adults, but lead an independent existence immediately after escaping from the egg.

The lobster egg is about $\frac{1}{8}$ inch in diameter. When newly laid it is usually of a dark-green color, but is sometimes light-grayish or yellowish-green.

The known maximum number of eggs produced at one time by a lobster is 97,440; the average from lobsters taken for market is 10,000 to 12,000. The number depends largely on the size of the lobster, apparently in conformity to the following rule: The numbers of eggs laid by given lobsters vary in a geometric scale, while the lengths of the lobsters vary in an arithmetic scale.

The following table illustrates, with approximate accuracy, the egg-producing capacities of lobsters of the lengths indicated under normal conditions:

Length of lobster.	Number of eggs laid.
8 inches.....	5,000
10 inches.....	10,000
12 inches.....	20,000
14 inches.....	40,000
16 inches.....	80,000

MOLTING AND GROWTH.

The act of shedding the shell, or molting, is important and critical. It is only after shedding that growth takes place; during the early stages of the lobster's existence this function is often exercised in a comparatively short time, while later it occurs only at long intervals. Molting in the lobster consists in throwing off the entire external skeleton, together with the lining of the digestive tract.

The first molt takes place about the time the young emerges from the egg, when it is about a third of an inch long, and many lobsters do not survive this. During this first stage the larval lobster swims at or near the surface. A second molt ensues in from 1 to 5 days, and the lobster enters on its second stage, its average length being about two-fifths of an inch and its habits similar to the first stage. In 2 to 5 days another molt takes place, and the length of the larva increases to about half an inch. This is followed in 2 to 8 days by another molt, and the lobster enters on the fourth stage, when its length becomes slightly greater. From 10 to 20 days later the fifth molt ushers in the fifth stage, after which the surface-swimming habit is discarded and the larva goes to the bottom and begins to assume the characteristics of the adult. This stage lasts 11 to 18 days, and in it the young lobster has attained a length of about three-fifths of an inch. From this time on the molts are at longer and longer intervals until the fully mature condition is reached, when shedding takes place only once in one or two years.

The food of lobsters during the larval stages consists chiefly of small crustaceans. A very pugnacious instinct then characterizes them, and active cannibalism prevents their artificial rearing for lack of abundant natural food.

Larval lobsters are very susceptible to the influence of the sun (heliotropic) while in the first three stages, being attracted by bright rays to the surface of the ocean or to the side of a vessel. This peculiarity is lost during the fourth stage.

During the first year the young lobster, which since the fourth stage has become more and more like the adult in form and habits with each molt, attains a length of about 2 or 3 inches. At the end of the second

year the length is 5 to 7 inches. By the end of $4\frac{1}{2}$ or 5 years a length of about 10 inches is reached. The rate of growth, however, depends greatly on the environment, the abundance of food being a very important factor.

The adult lobster usually molts in summer, and in the case of the female, shortly after the hatching of the eggs. As several months are required for the new shell to acquire the hardness of the old; as newly-laid eggs are rarely found on a soft-shell lobster; as molting does not ensue while the eggs are on the swimmerets; and, furthermore, as dissection has shown that the ovaries of a lobster whose eggs have recently hatched are in an immature condition and will not yield eggs until the succeeding year, it follows that the mature lobster deposits eggs not oftener than once in two years, with an alternating molt.

. SIZE AND WEIGHT.

The average size of lobsters caught for market is now much less than it was in the earlier days of the fishery, and their average weight is probably not over 2 pounds. A lobster 9 inches long weighs, on an average, $1\frac{1}{4}$ pounds; a $10\frac{1}{2}$ -inch lobster, $1\frac{3}{4}$ pounds; a 12-inch lobster, 3 pounds; and a 15-inch lobster, 4 to 5 pounds; while a lobster 20 inches long weighs 20 pounds or more. Lobsters weighing as much as 15 or 20 pounds are uncommon, and those weighing over 20 pounds are very rare. Up to a recent date, the largest lobster of authenticated weight was about 25 pounds. In 1897, however, 3 lobsters, each weighing over 30 pounds, were taken off Sandy Hook, N. J., the weight of the largest being 33 pounds.

The male lobster weighs more than the female of the same length, the difference in 11-inch lobsters, for instance, being about a quarter of a pound.

The size at which the lobster attains sexual maturity is a very important question. In the New England and Middle States and the Canadian Provinces the laws relating to the minimum size of marketable lobsters are quite various and illustrate the absence of definite information on this subject. In Maine, Massachusetts, New Hampshire, and New York the minimum limit of size of lobsters that may be sold is now $10\frac{1}{2}$ inches; in Rhode Island it is 10 inches, and in Connecticut it is 9 inches. In the British Provinces the limit is much lower than in Maine.

Investigations conducted by the Fish Commission on the New England coast show that the female lobster attains maturity when from 8 to 12 inches long. Comparatively few lobsters under 9 inches in length lay eggs. Of over 1,000 egg-bearing lobsters collected at Woods Hole during a period of years, less than 2 per cent were under 9 inches long. On the other hand, by the time they have reached the length of $10\frac{1}{2}$ inches most lobsters will have produced eggs, and this should be the minimum size permitted in the markets.

COMMERCIAL VALUE.

The lobster is the most important crustacean of the United States. It is the object of a special fishery, carried on with pots or traps, in all the coastal States from Delaware northward, and also in Nova Scotia, New Brunswick, Prince Edward Island, Quebec, and Newfoundland. In Maine, where the fishery is more important than in any other State, the lobster is the principal fishery product. In 1892 over 3,500 persons were engaged in this fishery in the United States; the capital invested was about \$650,000, and the catch amounted to 23,725,000 pounds, valued at \$1,062,000. In 1880 the yield was but little smaller (20,240,000 pounds), but the market value was much less, being only \$488,000.

Between 1889 and 1892 the New England lobster catch decreased over 7,000,000 pounds, or 23 per cent, while the value increased over \$200,000, or 25 per cent. For a number of years this fishery presented the anomaly of a diminishing supply and an augmented catch, owing to the more active prosecution of the business; but the decline in the yield has for some time been unchecked, notwithstanding the employment of more apparatus and the prolongation of the fishing season. With a singular disregard for their own welfare, many fishermen have continually violated the State laws for the protection of small, immature lobsters and females bearing eggs. Only the rigid enforcement of restrictive measures by the States and the extensive artificial propagation of the lobster can ward off the destruction which threatens this valuable fishery.

INCEPTION AND PROGRESS OF LOBSTER-CULTURE.

If egg-bearing lobsters were not liable to destruction by man, artificial propagation would hardly be necessary. Notwithstanding the enactment of stringent laws prohibiting the sale of "berried" lobsters, the frequent sacrifice of such lobsters, with their eggs, and of many immature lobsters, has seriously reduced the lobster output and rendered active and stringent measures imperative. By the present methods millions of lobster eggs are annually taken and hatched that would be lost, and the females producing them, amounting to several thousands, are liberated.

Prior to 1885 experiments had been conducted at various points looking to the artificial propagation of the lobster. The only practical attempts of this nature previous to those made by the Fish Commission were by means of "parking," that is, holding in large naturally inclosed basins lobsters that had been injured, soft-shelled ones, and those below marketable size. Occasionally female lobsters with spawn were placed in the same inclosures. One of these parks was established in Massachusetts in 1872, but was afterward abandoned; another was established on the coast of Maine about 1880. It was soon demonstrated, however, that the results from inclosures of this character, so far as the rearing of the lobsters from the young were concerned, would not be sufficient to materially affect the general supply.

The completion of the new marine laboratory and hatchery at Woods Hole in 1885, with its complete system of salt-water circulation, permitted the commencement of experiments in artificial hatching on a large scale, which had not been practicable theretofore, although small quantities of lobster eggs, as well as those of other crustaceans, had been successfully hatched. In 1886 the experiments had progressed so successfully that several million eggs were collected and hatched at Woods Hole, the fry being deposited in Vineyard Sound and adjacent waters. From 1887 to 1890, inclusive, the number of eggs collected was 17,821,000.

From the eggs collected up to 1889 the average production of fry was about 54 per cent. During these years experiments were conducted as to the best method of hatching the eggs. The various forms of apparatus used were the Chester jar, the McDonald tidal box, and the McDonald automatic hatching-jar. In 1889 the results secured in the latter form of apparatus were so much better than with the others that it was adopted, and in 1890, from the 4,353,000 eggs collected, over 81 per cent yielded fry. Work was continued at Woods Hole on about the same scale until 1894, when the collections aggregated 97,000,000 eggs. In the same year lobster propagation was undertaken at Gloucester and a collection of 10,000,000 eggs was made there.

During the fiscal year 1896 the number of eggs taken by the Fish Commission was 105,188,000, the resulting fry liberated numbering 97,579,000, or about 93 per cent; and in 1897 the collections amounted to 150,000,000 eggs, of which 135,000,000, or 90 per cent, were hatched.

COLLECTION OF EGG-BEARING LOBSTERS.

Although the new eggs appear on the lobsters during the months of July and August, no special effort is made to secure egg-bearing lobsters until the following spring. The collections usually commence in April and continue until the middle of July. At Woods Hole it has been the recent practice to receive at the station and place in the hatching-jars during the fall and winter any lobsters having external eggs that may be captured by local fisherman. The collecting-grounds extend from New London, Connecticut, to Rockland, Maine. For Woods Hole station eggs are secured from fishermen operating between New London, Connecticut, and Plymouth, Massachusetts.

The most important grounds in Connecticut are in the vicinity of New London and Noank; in Massachusetts, New Bedford, South Dartmouth, Plymouth, Woods Hole, and numerous localities in Buzzards Bay and Vineyard Sound. Eggs for the Gloucester station are secured from the fishermen operating between Boston and Rockland, which territory comprises the most important lobster fishery in the United States. The schooner *Grampus* is used in making the collections between Portland and Rockland, the lobsters being delivered at Gloucester early in the season and later on to the steamer *Fish Hawk*, which is stationed at a suitable point in Casco Bay.

As the laws of Massachusetts, New Hampshire, and Maine prohibit the holding of the "berried" lobsters by the fishermen, arrangements are made with the State authorities by which certain officials of the Fish Commission are appointed deputy wardens and authorized to hold egg-bearing lobsters for fish-cultural purposes in live-boxes. Early in the spring all of the lobster fishermen in the territory referred to above are visited by agents of the Commission, who arrange with them to hold all of their egg lobsters in live-cars until called for, at a price agreed on.

Collections are made from Woods Hole and Gloucester by steam launches and sailing vessels. The steam launches visit the near points three to four times a week to obtain egg-bearing lobsters. The vessels collect at more distant points in Connecticut and Maine. Local agents at Boston and Plymouth, Massachusetts, and Kittery Point, Maine, also collect egg-bearing lobsters, which are held in live-boxes until the agent has a sufficient number to make a trip. On the arrival of the vessel or launch at the station the lobsters are transferred to tanks supplied with running water and held until the spawn-taker is ready to strip the eggs.

TAKING AND MEASURING THE EGGS.

The receptacle into which the spawn-taker strips the eggs from a lobster is either a glass jar (9 inches in diameter) or a water-bucket, which, after thorough cleaning, is partly filled with water.

The operator, with his left hand, grasps the lobster from above and turns it on its back, lowering it into the spawning-vessel head downward. By pressing it firmly against the sides of the jar it is prevented from using the anterior part of its body or its mandibles. The hand is then slipped farther back toward the tail and the segmented portion of the body is held firmly to prevent its closing. The lobster is then ready for stripping. A rather dull, short-bladed knife is used to separate the eggs from the swimmerets, to which they are attached by hair-like fibers; stripping begins at the last pair of swimmerets and gradually proceeds toward the body. As the eggs are scraped off they fall into the water in the jar. Some which adhere to the claws of the lobster are washed off by means of a small stream of water. The lobster is then put back into a tank, where it remains until liberated.

Lobsters received by the local agents at Boston and Kittery Point are held until a suitable quantity is on hand and are then stripped, the eggs being taken to the station in transportation cans and the adults released. Early in the spring the eggs stand transportation well, but late in the season, as incubation becomes more advanced, they are very delicate and are quickly affected by rough handling or sudden changes in temperature.

Before being transferred to the hatching-vessels the eggs are accurately measured, generally with a glass graduate, into which they are poured, the water being drawn off. The basis of measure is an ounce, which contains about 6,090 eggs.

HATCHING APPARATUS AND OPERATIONS.

Experiments conducted during a series of years having demonstrated that the automatic hatching-jar was the best form of apparatus for hatching lobster eggs, it has been adopted at the stations of the Commission since 1889. A full description of this jar is given in the article on shad-culture, pp. 150-152. The manipulation and operation of the jar is practically the same as with shad eggs, except that frequently, where the water supply is inadequate, three jars are connected by means of rubber tubing and the water used over and over. This is accomplished by connecting the overflow from the first jar with the supply to the second and so on, but can only be done during the early stages before the fry commence to hatch. When first placed in the jar the eggs are matted together by the fine hair-like fibers, but after a few days they separate and work very much like shad eggs.

From 400,000 to 500,000 eggs (equivalent to about 2 to 2½ quarts) are usually placed in each jar, although at times when the hatchery is crowded a few more may be successfully cared for.

The fry pass voluntarily from these jars to cylindrical glass jars, 9 inches in diameter and either 9 or 18 inches high, placed in the center of the table and covered with cheese-cloth at the top to prevent their escape.

The period of incubation depends entirely upon the age of the egg when collected. For example, eggs taken in October do not hatch until the following May, whereas eggs collected in June frequently hatch in 24 hours after being placed in the jars. During one season eggs collected from December 12 to January 25, numbering 1,717,000, at a temperature of 45°, commenced hatching May 25 at a temperature of 54°. To determine how soon the new-laid eggs can be taken from the parent and hatched artificially, collections were begun early in July and continued until fall, for several seasons, the eggs being placed in hatching-jars at the Woods Hole Station; all those collected prior to October 15 died. In November, 1895, 15,000,000 were placed in jars and carried through the winter under very unfavorable conditions, but hatched with a loss of only 50 per cent. The density of the water at Woods Hole varies from 1.023 to 1.025, its average temperature being from 49° to 64° during the months of April, May, and June.

THE LOBSTER FRY.

Owing to the cannibalistic habits of young lobsters when closely crowded, it has been the policy of the Commission to liberate the fry as soon after hatching as possible. They are taken out in ordinary 10-gallon transportation cans, about 200,000 being placed in a can for short shipments and 125,000 for long shipments, and liberated in the vicinity of the grounds from which the adult lobsters were taken. When this is impracticable, they are liberated in Vineyard Sound and Buzzards Bay with an outgoing tide, so as to insure their wide distri-

bution. The question of the transportation of lobster fry any great distance is still an unsettled one, as in but few instances has it been attempted to ship them by rail, and then the trips were comparatively short—namely, from Woods Hole to Cold Spring Harbor, New York; from Woods Hole to Provincetown and Plymouth, and from Gloucester to Kittery Point. The shipments from Woods Hole have all been very successful, and there seems little doubt that the young lobster will stand transportation for 24 hours with excellent results.

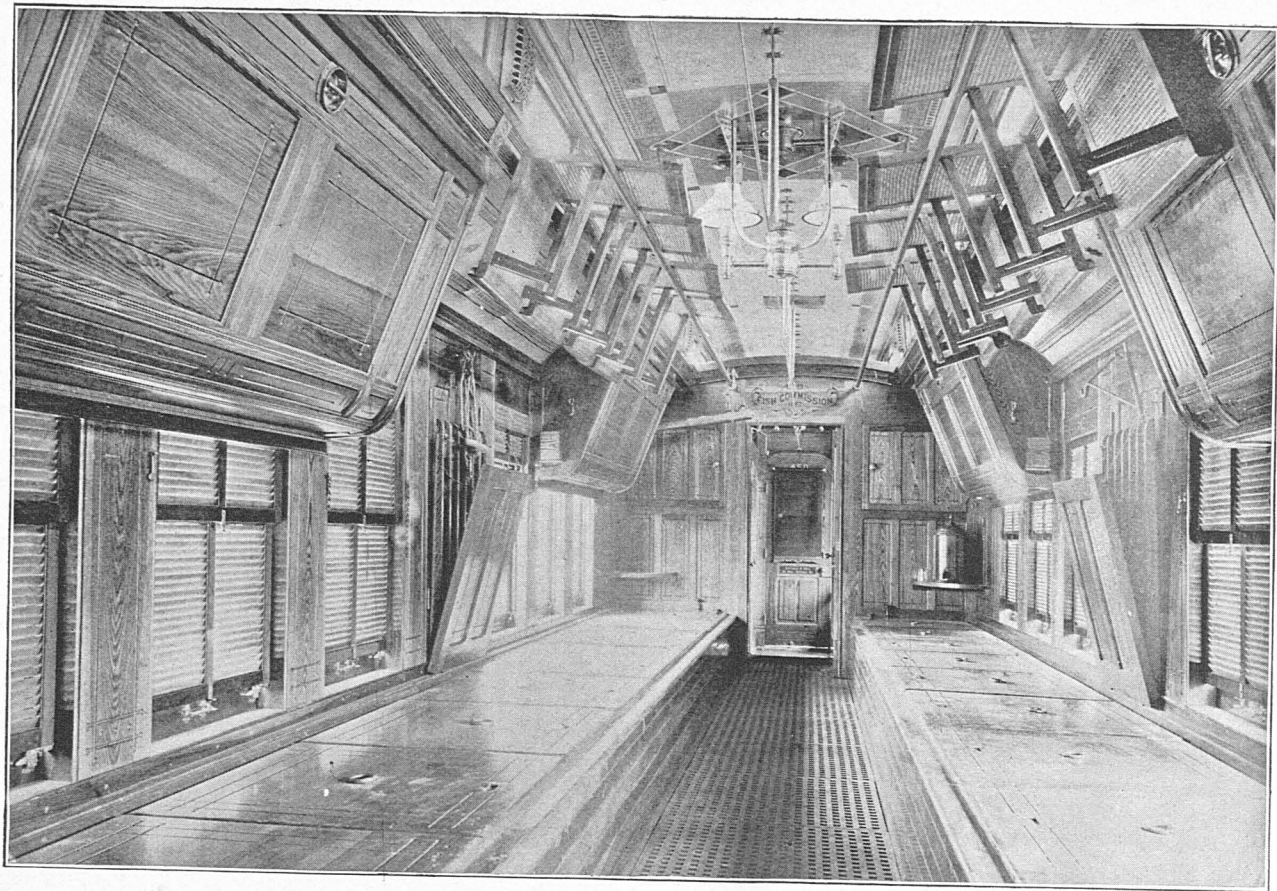

INTERIOR OF TRANSPORTATION CAR, SHOWING BERTHS CLOSED AND CHAIRS HUNG UP SO THAT COMPARTMENTS FOR FISH CAN BE OPENED.

THE TRANSPORTATION OF FISH AND FISH EGGS.

During the earlier years of the Commission young fish were carried by messengers in baggage cars on regular passenger trains, but as the work increased it was found that this method was inadequate and that other arrangements must be made to transport the large numbers of fish which were being hatched. Accordingly, in 1879 and 1880, experiments were successfully made in moving shad fry in specially equipped baggage cars, and it was found that large numbers of fish could be economically moved with little loss. A car was therefore constructed specially adapted for the distribution of live fishes, the requirements of such a car being a compartment for carrying the fish in which an even temperature could be maintained, proper circulation of water and air in the vessels containing the fish, and sleeping and living accommodations for the messengers attending them.

A baggage car, the body of which was 51 feet long, 9 feet 10 inches wide, 13 feet 8 inches high, was purchased. At one end of the car was a room containing a stove, sink, and berth for the use of the cook, besides a boiler, pump, etc.; and at the other were two sections of berths, like those in a Pullman car, which would accommodate two men on each side. Each compartment was about 7 feet long. In its center was a refrigerator compartment 30 feet 3 inches long by the full width of the car, and extending up to the clear story. The ice was carried in two racks, holding 1 ton each, which were located in the corners of the refrigerator, diagonally opposite each other. Cylinder cans, placed on galvanized iron tanks 9 feet 4 inches long, 28 inches wide, and 8 inches high, were provided in which to carry the fish. The tanks were placed on opposite sides of the car, with a passageway between them.

An apparatus for circulating water was arranged in the following manner: In the top of the car, extending the full length of the clear story, was a long, semicircular iron tank 12 inches in diameter, which was filled through the top of the car. From this the water was brought into a 6-inch pipe extending all around the top of the refrigerator compartment. The pipe contained a sufficient number of pet-cocks to supply the number of cans carried, the water being conveyed to the cans through rubber tubing. From the cans it passed into the tanks through the same-sized tubing, whence it was drained into 2-inch pipes underneath the car, and from these pipes was pumped up to the tank in the clear story.

While this circulating apparatus worked well, its arrangement necessitated the carrying of a large amount of water in the top of the car,

thus causing it to roll from side to side in such a manner as to make it unsafe. It was also found that while the refrigerator compartment carried the fish safely, the health of the messengers was injuriously affected owing to the sudden changes of temperature experienced in going to and from the compartment. Accordingly, another car was built in which these defects were remedied, and the original car was altered to conform to the improved plan.

The Commission now has four transportation cars in use. While they differ somewhat in construction and arrangement, three of them are essentially alike; the fourth is simply a baggage car with living quarters and circulating apparatus. The car known as No. 2 is regarded as the best type. Its body is 52 feet 7 inches long; from buffer to buffer, 59 feet 9 inches; width, 10 feet; height, from top of rail to top of car, 14 feet 3 inches. It is equipped with 6-wheel Pullman trucks, paper wheels, combination couplers, etc., so that it can be hauled on passenger trains. Underneath, between the trucks, are boxes for carrying provisions, tools, extra couplers, and a water-tank. Inside the car is finished in white ash, and due arrangements are made for the comfort and convenience of the crew. In one end is an office for the use of the captain, containing a sleeping-berth, desk, and toilet facilities; at the other end is the kitchen, with lockers for dishes, also the air-pump, steam-pump, and a 5-horsepower boiler for furnishing necessary power.

The fish are carried in tanks or cans arranged in two refrigerator compartments on each side of the passageway. Over these compartments are two upper berths on each side for the accommodation of the crew, whose meals are served on a large table, placed when in use in the passageway in the center of the car. Chairs without legs are provided, so that they can be placed on top of the refrigerators.

The refrigerator-chambers are 26 inches high and 34 inches wide, and provided with lids; the partitions are filled with cork, which is used on account of its nonconducting properties. At one end of the chambers is an ice-box, which holds about three-fourths of a ton of ice.

The transportation-tanks used in carrying yearling and adult fishes are made of heavy galvanized iron, and are 27 inches long, 27 inches wide, and 24 inches deep, holding 52 gallons each. They are heavily coated with asphalt before being used.

For the transportation of fry ordinary 10-gallon iron cans, tinned, are used. These cans are 24 inches high, 12 inches in diameter on the outside, with sloping shoulders and cover, and two handles on the sides for convenience in moving. The water is introduced by means of a rubber hose connected with the pressure tank, or simply with a dipper or bucket.

The supply of water is carried in an iron pressure-tank of 500-gallon capacity, which is located in the body of the car next to the office. The water is circulated by means of a steam-pump through galvanized-iron

piping, which runs from the pump to the pressure-tank, thence along the sides of the refrigerator to the transportation-tanks, whence it flows by gravity to a tank below the floor. From here it is pumped into the supply tank for redistribution.

In order to provide sufficient air circulation, the air is driven by a pump to a 30-gallon reservoir in the top of the car over the boiler-room, from which it is taken to the transportation-tanks or cans through two lines of iron piping running along the sides and top of the car. One pet-cock is placed in the pipe for each tank to be supplied with air, which comes to it through a hole $\frac{1}{8}$ inch in diameter. From the pet-cock the air is carried into the tank with rubber hose and released in the water through liberators made of American linden, placed in hard-rubber holders.

Before the present system of water circulation was adopted the water was taken from four 40-gallon tanks located in the bottom of the refrigerator compartments, pumped into four 60-gallon supply-tanks, from which it flowed through the transportation-boxes and was returned thence to the lower tanks. The water supply was at first connected with a rotary hand-pump, and afterwards an arrangement was adopted to furnish power for the pump and an air-blower, by means of a friction wheel placed on the truck at one end of the car. This wheel was attached near one end to the top of the truck, so that it rested on the tread of the car wheel and was held there by two spiral springs. When not in use, it could be elevated above the car wheel by a lever operated from inside the car. Power was transmitted from the friction wheel by means of a countershaft and rubber belting. The friction wheel gave a great deal of trouble, however, as it was impossible to make it strong enough to stand the wear to which it was subjected. As the action of the truck springs, while the car was in motion, moved the truck frame up and down—sometimes 3 to 5 inches—the friction wheel would be jolted out of position, and so uncertain was its operation that it could not be relied upon and the pump and blower had to be worked by hand.

This car is also fitted up with a hatching outfit, consisting of eight lead-lined boxes about 6 inches high, which may be placed on top of the refrigerators and made to fit in place of the lids, which can be removed. These boxes each hold six McDonald jars. An aquarium, specially made for the work, is placed in the center of each box, with three jars on each side of it. The jars and aquarium are securely wedged in the box, so that they can not move. The supply of water for the jars comes from the supply-pipes in the refrigerator compartments, the pipe coming up through the top of the refrigerator near the center, then branching out on each side with pet-cocks in it, to which is attached the rubber tubing to supply the jars. The overflow is through a pipe leading out of the bottom of the boxes into the tank under the car.

Fry are carried in cans, and yearlings and adults in the transportation tanks. Great care is taken not to make a sudden change in the

temperature. If the air and water circulations are not used it is necessary to aerate the water with a dipper, that is, to take a dipperful of water from the can and, holding it up about 2 feet, pour it back, thus taking air with the water to the bottom of the can. This is done as often as is necessary to keep the water fresh.

Whitefish fry are carried in water at a temperature from 33° to 45° F. If necessary to reduce the temperature, ice can be placed in the water with the fry. If the air and water circulations are used, about 40,000 fry can be carried in each can. Without the circulation 20,000 are carried, and in order to aerate them it is necessary to draw off in a pail, through a screened siphon, about one-half the water in the can. This is then thoroughly aerated in the pail with a dipper and returned to the can, with a small amount of fresh water added. When a car arrives at its destination, the cans are taken to a tugboat or steamer and carried to the spawning-grounds where the whitefish are to be planted, by carefully lowering the cans into the water and allowing the fry to escape. On board the boat they are given fresh water as fast as is required to keep them alive.

Shad fry are carried in water at a temperature of from 55° to 65°, depending on the temperature of the water in which they were hatched. These fry can not be carried successfully with the circulating system of water or air, and aeration, by the use of the dipper, is therefore necessary. From 20,000 to 30,000 are carried in each can. When the water is to be changed, it is drawn off through a siphon into a pail, the head of the siphon being in a wire cage, covered with cheese-cloth to prevent the fry from escaping. After the water in the pail has been thoroughly aerated and ice added to bring the temperature down to what is required, it is poured back through a large funnel which reaches nearly to the bottom of the can. To prevent the force of the water from injuring the delicate fry, the lower part of the funnel for about 6 inches is made of perforated tin. When long trips are made, the sediment which collects on the bottom of the cans is removed, as soon as it is noticed, by drawing it off through a siphon into a pail. Should any fry come out with it, they are carefully returned to the can by dipping them out after the sediment has settled to the bottom of the pail. If a trip lasts five or six days, the cans are cleaned every other day by transferring the fry with a dipper from one can to the other and cleaning the empty one before the fry are returned to it. Shad fry are more tender than any other young fish moved on the cars, and the greatest care is necessary in handling them.

Trout and salmon fry are carried in water at a temperature of 36° to 46°, though rainbow trout are sometimes transported in water 10° or 15° warmer. If it is necessary to reduce the temperature, ice is placed in the cans with the fish. Each can contains 5,000 trout fry, and 2,000 to 3,000 salmon fry, when the air and water circulations are used; without air circulation, 3,000 or 4,000 trout, and 1,200 to 1,500 salmon

fry are allowed to each can—the number depending on the length of the trip and age of the fry. These fish are moved as soon as the sacs are absorbed, or when they first begin to swim up from the bottom. If shipped before this period of life, they are liable to collect on the center of the can in the bottom and smother. If the fry will keep away from the mouth of the can, the water is aerated by dipping it directly from the can and letting it fall back; but if the fish do not go down when the dipper is introduced, the water is siphoned into a pail, aerated, and then poured back.

Small yearling trout are sometimes carried in cans, but usually in the galvanized-iron tanks; 100 to 200 are put in each can if the air circulation is used, and the water is kept cool by introducing ice. As salmon and lake trout are more delicate than the others, the number placed in each can is reduced. When shipping adult trout but few can be taken in each tank, only from 20 to 50 if they are of large size. They are given all the air and water circulation possible and carried at a low temperature. Incessant watchfulness is necessary in moving these fish. When the fish are in distress they come to the surface of the water, and if the water is then vigorously aerated they will return to the bottom of the tank.

When black bass are distributed in the fry stage they should be shipped in water from 40° to 60° F., according to the temperature of the water from which they are taken; but it is considered preferable to hold these fish in the ponds or feeding-troughs until they are from three to six months old, when they will have attained a length of from 1½ to 3 or 4 inches, fish hatched at the same time often varying considerably in length. These older fish also require a temperature of from 40° to 60°, according to circumstances, when they are transported. Young black bass are very voracious, and begin to eat each other as soon as they are confined in cans or tanks for transportation. The number of bass carried in each tank is approximately as follows: Fifty 8 to 12 inches long; one hundred and twenty 5 to 8 inches long; two hundred and fifty 2 to 5 inches long.

Crappie are carried in the same manner as black bass, although it is more difficult to handle them. Rock bass are commonly carried in cans, about 500 to 700 in each if the fish are about an inch long. The temperature of the water is from 40° to 60°.

Codfish fry are moved in cans with water of a temperature of 33° to 38°. The trips are usually of short duration. The water is aerated by drawing it from the can through a screen siphon into a pail and returning it after it has been thoroughly aerated.

Large lobsters, on long trips, are packed in seaweed in wooden trays about 6 inches high and of a size convenient for handling. Strips of wood attached to the bottom of trays have open spaces between them to allow air circulation. About 2 inches of seaweed are spread on the bottom of the tray and the lobsters placed on it with their claws

toward the outer ends, so that they can not injure each other, and the trays are then filled with seaweed. They are packed in the refrigerator compartments, and the temperature of the air is kept, if possible, at from 40° to 48° F. A supply of salt water, filtered through cotton, is taken along, and the lobsters are sprinkled with it three or four times a day, and they are also daily overhauled and repacked. If the desired temperature is maintained, 50 to 60 per cent can be carried for five or six days. Lobster fry are moved in the same manner as codfish fry.

In transporting adult salt-water fishes, as many as possible are placed in the tanks without overcrowding them. The water is kept fresh by air circulation only. Ice is packed around the galvanized iron tanks to keep them cool, and if necessary to reduce the temperature a can filled with ice is placed in the water. Marine fishes have been transported successfully for 6 days or more.

A large number of fish are distributed yearly by messengers, acting independently of the cars. Each messenger is supplied with a sufficient number of 10-gallon cans, and is equipped with a dipper, a 5-gallon iron pail, a large tin funnel with a perforated bottom, a thermometer, and a piece of $\frac{3}{4}$ -inch rubber hose, about 4 feet long, for use as a siphon, besides a supply of ice.

When it is necessary to renew the supply of water, the messenger sees that it is clean, fresh, free from lime, iron, and other deleterious substances. Especial attention must be given to this in passing through limestone regions, and fresh water must be tested before the supply on hand is thrown away. The fry are cared for and aerated in the same manner as has been already described for transporting them in cans.

SPAWNING SEASONS OF FISHES PROPAGATED, CHARACTER OF FISH EGGS, PERIOD OF INCUBATION, ETC.

In the following table there are presented, in a form convenient for reference, some of the more important facts connected with eggs of the fishes artificially cultivated in the United States. It should be understood that there is considerable variation in many of the items, depending on climatic conditions, size and age of fish, etc.; the information for such can therefore be only approximately correct. For certain of the less important fishes, it is possible, from the data available, to supply only a part of the information indicated by the column headings. The spawning season given is generally that of wild fish in the regions where fish-cultural work is prosecuted; this varies much with latitude and local conditions.

Fish eggs, as regards their physical characters, naturally fall into four classes, as follows:

(1) Buoyant or floating, as the eggs of the cod, mackerel, and most pelagic fishes, which come to the surface when first deposited and remain there during at least the early stages of incubation.

(2) Semi-buoyant, as the eggs of the shad and whitefish, whose specific gravity is but slightly greater than that of water.

(3) Heavy, non-adhesive, as the eggs of salmon and trout.

(4) Heavy, adhesive or glutinous, as the eggs of the flatfish, sea herring, yellow perch, and most pond fishes.

The differences in the types of hatching apparatus depend primarily on the foregoing characters of the eggs.

At the hatching stations the size of eggs is determined by placing a number of moist eggs, shortly after taking, on a flat surface, side by side, and noting how many are required to cover a linear inch. Owing to capillary attraction between adjoining eggs leading to compression or flattening of the contiguous sides, this method is liable to slight error, the extent of which is in inverse proportion to the size of the eggs.

By means of the microscope, accurate measurements of small eggs may be made. The size of eggs of a given species often varies considerably, sometimes amounting to 25 per cent.

Spawning seasons of fishes propagated, character of eggs, period of incubation, etc.

Name of fish.	Spawning season.	Character of eggs.	Diam-eter of egg.	Average num-ber of eggs per fish.	Maximum egg production.		Period of incubation.		Yolk-sac absorbed.	
					Number of eggs.	Weight of fish.	Time.	Mean tempera-ture.		
Aloewives (<i>Pomolobus aestivalis</i> , <i>P. pseudo-harengus</i>).	Spring.....	Heavy, adhesive.....	<i>Inch.</i> 7/8	100,000		<i>Pounds.</i>	6 days.....	60	40 days.	
Atlantic salmon (<i>Salmo salar</i>).....	Oct. to Nov.....	Heavy, non-adhesive.....	7/8	9,363	20,992	22 1/2	11 days.....	55		
Black basses (<i>Micropterus salmoides</i> , <i>M. dolomieu</i>).	March to June.....	Heavy, adhesive.....		3,000 to 10,000			157 days.....	37		
Black-spotted trout (<i>Salmo mykiss pleuriticus</i>).	May to July 15 (Colo.).....	Heavy, non-adhesive.....	1/2	1,000 to 6,000			10 to 12 days.....	60	20 to 30 days.	
Blueback salmon, or redfish (<i>Oncorhynchus nerka</i>).	Aug. to Sept.....	do.....		1,000 to 1,200						
Brook trout (<i>Salvelinus fontinalis</i>).....	Sept. to Oct.....	do.....	1/2	500 to 1,500			45 days.....	52 to 60	25 days at 50°. 40 days at 37°. 12 days at 38°.	
Cod (<i>Gadus callarias</i>).....	Nov. to April.....	Buoyant, non-adhesive.....	1/2		9,100,000	75	50 days.....	50		
Crappies (<i>Pomoxis sparoides</i> , <i>P. annularis</i>).	April to June.....	Heavy, adhesive.....	1/2				125 days.....	37		
Cunner (<i>Ctenolabrus adspersus</i>).....	May to July.....	Buoyant, non-adhesive.....	7/8				21 days.....	43	15 days at 38°.	
Flatfish (<i>Pseudopleuronectes americanus</i>).	Feb. to April.....	Heavy, adhesive.....	7/8	500,000	1,462,000	3 1/2		38		
Four-spotted flounder (<i>Paralichthys oblongus</i>).	May (Mass.).....	Buoyant, non-adhesive.....	7/8					51 to 56		
Frostfish or round whitefish (<i>Coregonus quadrilateralis</i>).....	Nov. to Jan. (N. Y.).....	Heavy, adhesive.....	1/2	3,500	12,000	1 1/2	5 days.....	56	10 to 20 days.	
Golden ide (<i>Idus idus</i>).....	April (D. C.).....	do.....	7/8				150 days.....	33		
Golden trout (<i>Salvelinus alpinus aureolus</i>).	November.....	Heavy, non-adhesive.....	1/2	2,300	4,100	5 1/2	5 or 6 days.....	56	67 days at 39°. 8 or 10 days. 10 days at 41°.	
Grayling (<i>Thymallus ontariensis</i>).....	April to May.....	do.....	1/2	3,000 to 4,000	5,200	1 1/2	123 days.....	39		
Haddock (<i>Melanogrammus aeglefinus</i>).....	Feb. to May.....	Buoyant, non-adhesive.....	7/8	100,000	250,000	12	14 to 20 days.....	50 to 62		
Lake herring (<i>Argyrosomus artedii</i>).....	November.....	Semi-buoyant, non-adhesive.....	7/8				13 days.....	41	5 to 15 days.	
							15 days.....	37		
							130 days.....	34 1/2		
Lake sturgeon (<i>Acipenser rubicundus</i>).....	May to June.....	Heavy, adhesive.....	1/2				7 days.....	62 to 66	40 days.	
Lake trout (<i>Cristivomer namaycush</i>).....	Oct. to Nov.....	Heavy, non-adhesive.....	7/8	5,000 to 6,000	14,943	24	12 to 20 days.....	55 to 65		
Landlocked salmon (<i>Salmo salar sebago</i>).....	Oct. to Nov.....	do.....	7/8	1,426	3,069	6 1/2	75 to 90 days.....	40 to 45		
Lobster (<i>Homarus americanus</i>).....	April to July; ¹ July to Aug. ²	Heavy.....	1 1/2	10,000 to 12,000	97,440	5 1/2	169 days.....	37		
							10 or 11 months.....			
Loch Levent trout (<i>Salmo trutta levenensis</i>).	Oct. to Nov.....	Heavy, non-adhesive.....	1/2					70 to 80 days.....	45	30 days.
Longjaw whitefish (<i>Argyrosomus prognathus</i>).	Summer (chiefly).....	Semi-buoyant, non-adhesive.....	7/8							
Mackerel (<i>Scomber scombrus</i>).....	May to July.....	Buoyant, non-adhesive.....	7/8	41,000	546,000	1 1/2	5 days.....	55 to 58	6 days. 15 days.	
Menominee whitefish (<i>Argyrosomus quadrilateralis</i>).	Nov. to Jan. (N. Y.).....	Heavy, adhesive.....	1/2	3,500	12,000	35	15 days.....	55		

Muskellunge (<i>Lucius masquinongy</i>).....	March (N. Y.)	Semi-buoyant, slightly adhesive.	$\frac{1}{2}$	100,000	* 265,000	35	15 days.....	55	15 days at 55°.
Pollock (<i>Pollachius virens</i>)	Oct. to Dec.	Buoyant, non-adhesive	$\frac{1}{2}$	225,000	425,000		6 days	49	5 days. 30 to 40 days at 44°.
Quinnat salmon (<i>Oncorhynchus tshawytscha</i>).	July to Nov.	Heavy, non-adhesive..	$\frac{1}{2}$	5,000	8,000		9 days	43	
Rainbow trout (<i>Salmo irideus</i>)	Feb. to May (Cal.), May to July (Colo.), Nov. to Mar. (Va.)	do	$\frac{1}{2}$				35 days	54	
Rock bass (<i>Ambloplites rupestris</i>).....	April to June.	Heavy, adhesive.....					42 to 45 days..	50	30 days.
Sand dab (<i>Bothus maculatus</i>)	May (Mass.)	Buoyant, non-adhesive	$\frac{1}{2}$				10 to 12 days..	60	34 days.
Scotch sea trout (<i>Salmo trutta</i>)	Oct. to Nov. (Me.)	Heavy, non-adhesive..					8 days	51 to 56	
Scup (<i>Stenotomus chrysops</i>)	June (Mass.)	Buoyant, non-adhesive	$\frac{1}{2}$				169 days	36	
Sea bass (<i>Centropristes striatus</i>)	do	do	$\frac{1}{2}$				4 days	62	
Sea herring (<i>Clupea harengus</i>).....	Sept. to Dec. (New England).	Heavy, adhesive.....	$\frac{1}{2}$	30,000			5 days	59 or 60	
Shad (<i>Alosa sapidissima</i>)	Feb. (Fla.) to July (N. Y.)	Semi-buoyant, non-adhesive.	$\frac{1}{2}$	30,000	156,000		11 days	50	33
Sheepshead (<i>Archosargus probatocephalus</i>).	March (Fla.)	Buoyant, non-adhesive	$\frac{1}{2}$				40 days	55 to 68	
Silver salmon (<i>Oncorhynchus kisutch</i>)	September	Heavy, non-adhesive..		2,000			3 to 10 days...	77	
Spadefish (<i>Chaetodipterus fader</i>)	June to Aug. (Va.)	Buoyant, non-adhesive	$\frac{1}{2}$				40 hours	78	
Spanish mackerel (<i>Scomberomorus maculatus</i>).	April (N. C.) to Sept. (N. Y.)	do	$\frac{1}{2}$ to $\frac{1}{2}$	20,000			24 hours	84	
Spotted squeteague (<i>Cynoscion nebulosum</i>).	March (Fla.)	do	$\frac{1}{2}$				18 hours	78	
Squeteague (<i>Cynoscion regale</i>)	June (Mass.)	do	$\frac{1}{2}$				24 hours	77	
Steelhead (<i>Salmo gairdneri</i>)	Feb. to April	Heavy, non-adhesive..	$\frac{1}{2}$	3,000 to 5,000			2 days	60	
Striped bass (<i>Morone lineatus</i>)	May (Md., Va.)	Buoyant, non-adhesive	$\frac{1}{2}$		2,200,000		42 to 50 days..	50	
Sturgeon (<i>Acipenser sturio</i>)	Spring and summer.	Heavy, adhesive.....	$\frac{1}{2}$	1,680,000			5 days	58	
Tantog (<i>Tautoga onitis</i>)	May to July	Buoyant, non-adhesive	$\frac{1}{2}$	{ 150,000 (to 200,000)	1,142,600	9 $\frac{1}{2}$	6 days	65	
Tomcod (<i>Microgadus tomcod</i>)	Dec. (N. Y.)	Heavy, non-adhesive	$\frac{1}{2}$	25,000	43,740	1	2 or 3 days....	71	4 days at 40°.
Von Behr trout (<i>Salmo fario</i>)	Nov. and Dec.	do	$\frac{1}{2}$				15 days	69	
Wall-eyed pike (<i>Stizostedion vitreum</i>)	April in Lake Erie	Heavy, adhesive.....	$\frac{1}{2}$				35 days	40	
Whitefish (<i>Coregonus clupeiformis</i>)	Nov. to Dec.	Semi buoyant, non-adhesive.	$\frac{1}{2}$	35,000			17 to 20 days..	45	5 to 10 days.
White perch (<i>Morone americana</i>)	April and May	Buoyant, non-adhesive		40,000			150 days	34	
Yellow-finned trout (<i>Salmo mykiss macdonaldi</i>).	May 1 to July 15 (Colo.)	Heavy, non-adhesive	$\frac{1}{2}$	1,000 to 6,000			3 days.....	58	20 to 30 days.
Yellow perch (<i>Perca flavescens</i>).....	Feb. to April	Heavy, adhesive in bands.	$\frac{1}{2}$				45 days	52 to 60	

¹ Hatching season.

² Spawning season.

³ Only a portion of the eggs of this fish were obtained.

NOTES ON THE EDIBLE FROGS OF THE UNITED STATES
AND THEIR ARTIFICIAL PROPAGATION.

BY

F. M. CHAMBERLAIN,

Assistant, U. S. Fish Commission.

NOTES ON THE EDIBLE FROGS OF THE UNITED STATES AND THEIR ARTIFICIAL PROPAGATION.

The frogs are familiar representatives of the great class of cold-blooded vertebrates known as the Batrachia. The batrachians are intermediate anatomically and physiologically between the fishes and the reptiles (snakes, turtles, terrapins, alligators, etc.); they are chiefly characterized by the metamorphosis which the young undergo before assuming the functions and habits of the adults. The young are mostly aquatic and breathe by means of gills, which absorb oxygen from the water. Later the gills disappear and are replaced by lungs.

The frogs are included in the order *Salientia* (the leapers), distinguished by having a short, depressed body and four limbs, the hind pair being much enlarged and adapted to leaping and swimming; the tail, present in the young, disappears with age. In the related orders (*Urodela*, containing the salamanders and newts; *Proteida*, the mud-puppies or water-dogs, and *Trachystomata*, the sirens or mud-eels) the tail persists in adult life and the hind limbs are small, but the metamorphoses and habits otherwise more or less closely resemble the *Salientia*.

Associated with the frogs (*Ranidae*), in the order *Salientia*, are the families (*Bufo* and *Hyla*) to which the toads and tree frogs belong. The toads are very closely related to the frogs, but differ in having more terrestrial habits and, among other structural features, in the absence of teeth and the possession of an expansible thorax; their uncouth form and the pungent secretions which have brought them immunity from the attacks of other animals have added to the prejudice against their relatives, the frogs. The tree frogs are characterized by arboreal habits and corresponding changes in structure. More than 250 species of true frogs (*Ranidae*) are known. They are most numerous in Africa and the East Indies.

The edible frogs of the United States belong to the genus *Rana* (Latin, a frog). Of these, Professor Cope in his *Batrachia* of North America (1889) lists 13 species and 6 subspecies or varieties, to which there have since been some additions.

FOOD VALUE OF FROGS.

The value of frogs as food is now thoroughly recognized. The meat is white, delicate, and very wholesome and palatable. Although eaten at all times, it is in best condition in fall and winter; in spring it is of

relatively inferior quality. Only the hind legs are commonly utilized, the meat on the other parts of the body being edible, but in very small quantity. In some localities, however, the entire body, after the removal of the viscera, is fried with eggs and bread crumbs. The legs are prepared for the table by broiling, frying, or stewing.

A prejudice formerly existed against frogs as an article of food, perhaps based on their uncanny appearance and heightened through their appropriation by witches and empirics for spells in love affairs and the cure of various diseases. For a long time the French people alone availed themselves of this delicacy, though it was known to the Romans. From France the use of this food passed into Germany, England, and other parts of Europe, and later into the United States, where frogs are now more generally consumed than in any other country, and where, during the proper seasons, they may be found in the markets of any of the larger cities.*

FROG-HUNTING.

The business of taking frogs for market has greatly increased in recent years. It is now carried on in all sections of the United States, and is of economic importance in about fifteen States, while in nearly all the remaining States and Territories frogs are taken for local or home consumption, of which it is impossible to get a statistical account. The States supplying the largest quantities for the markets are California, Missouri, New York, Arkansas, Maryland, Virginia, Ohio, and Indiana. More frogs are taken in New York than in any other State, but on account of their comparatively small size their value is less than in Missouri and California. The Canadian Province of Ontario also yields a comparatively large supply of market frogs. According to inquiries of the United States Fish Commission, the annual catch in the United States is but little less than 1,000,000, with a gross value to the hunters of about \$50,000. The yearly cost of frogs and frog legs to the consumers is not less than \$150,000.

The localities in which especially important frog hunting is done are the marshes of the western end of Lake Erie, and Lewis and Grand reservoirs, in Ohio; the marshes of the Sacramento and San Joaquin rivers, California; the valley of the Kankakee River, Indiana; Oneida Lake, Seneca River, and other waters of northern New York, and the St. Francis River and the sunken lands of the Mississippi River, in Arkansas and Missouri.

In taking frogs for market, lines baited with red cloth, worms, or insects are extensively used; guns, small-bore rifles, and spears are also employed, and cross-bows are adopted for this purpose in Canada. They are often hunted at night, a lantern furnishing light for the

* While it is popularly supposed that the consumption of frogs in France is much larger than elsewhere, this is not the case, and, on the authority of the *Revue des Sciences Naturelles Appliquées* (1889), it may be stated that the annual consumption of frogs in the United States is ten times that in France.

hunter's aim, and at the same time blinding or dazing the frogs. After entering on their hibernation, many are dug out of the mud, large numbers often being found together at this time.

In the basin of the St. Francis River, in Missouri and Arkansas, where the business is important, frogs are captured by means of spears, with lines at the end of long rods, and with firearms. In the early part of the season, when the frogs retire to the mud during the cool nights, and only appear on warm, bright days, they are taken on hooks baited with red cloth and by guns and rifles. Later the bulk of the catch is made at night by means of spears with one to three barbed prongs. Two men usually hunt together in a boat, one rowing, the other standing in the bow with spear and a large reflector made especially for the purpose. The season in this region is principally from March to June. Only the hind legs are preserved; a pair of these weighs about half a pound.

The prices received for frogs varies greatly, and depends on the condition of the market, the size of the frogs, and the locality. Dressed legs yield the hunters from 12½ to 50 cents a pound, and live frogs from 5 cents to \$4 a dozen. In the Kankakee Valley, Indiana, for example, the prices received by the hunters are 75 cents a dozen for large frogs, 10 cents a dozen for medium-sized frogs, and 5 cents a dozen for small frogs, while in San Francisco the market price is \$3 to \$4 a dozen.

The unrestricted hunting of frogs threatens their practical extinction in all places where their abundance and shipping facilities or proximity to market render the business profitable. Already a marked decrease in the supply is manifest in Lake Erie, in northern New York, and other places, and in order to meet the increasing demand hundreds of people are experimenting or preparing to engage in frog-culture.

The need of definite information as to the methods of procedure has been generally felt and frequent inquiries concerning frog-culture are received by the United States Fish Commission. While the practicability of artificial propagation has not been demonstrated, it is evident that the number of salable frogs from a given area may be largely increased by artificial means. To undertake intelligent work in this line a knowledge of the natural history of the frog is essential.

HABITS AND DEVELOPMENT OF FROGS.

All frogs undergo a tadpole stage, though in some species this is so rapid as to lead the casual observer to think it omitted.

Upon the disappearance of frosts at the close of winter the hibernating frogs return to active life, and as the waters become warmer in the spring sun their notes are heard in suitable localities all over the country. In some species the song is distinctly a *chant d'amour*; in others it is continued long after the breeding season is over. During the breeding season the social instinct prevails, and species of usually solitary habits congregate in large numbers, thus becoming ready prey for the hunter.

The eggs are extruded by the female and are fertilized by the male as they pass out, very few failing to be impregnated. The process of oviposition or laying continues through several days, and during this period several hundred eggs may be deposited. The size of the ova varies with the species, but averages about 1.75 millimeters (.07 inch) in diameter. In passing down the oviduct the egg receives a thin coating of albuminous material; this rapidly swells when the egg enters the water and forms the well-known gelatinous mass in which the frog eggs are always found imbedded. The toad's eggs are laid in long strings and are readily distinguishable. The salamander's eggs are also placed in the water, but the gelatinous mass is somewhat firmer and the eggs are slightly larger than the frog's, and they are usually deposited somewhat earlier.

The eggs begin development, under favorable circumstances, as soon as fertilized, the rapidity depending mainly on the temperature of the water; incubation is much retarded by cold, and some seasons many eggs are killed by late frosts. At first the upper part of the eggs is black and the lower white, but the rapid growth of the black embryo makes the entire egg dark. The egg, which is at first spherical, soon becomes ovoid. In from 4 to 30 days the tadpole is able to wriggle out of its gelatinous envelope and shortly attaches itself to some plant or other support by means of a sort of adhesive organ in front of the mouth. At first the mouth and anus are closed, and food can only be obtained by absorption, the first food consisting of the gelatinous egg-envelope. In a short time the mouth and anus become functional, the alimentary canal lengthens, and macerated animal and vegetable matter becomes the food. The prevalent idea that the tadpole is exclusively vegetarian, based on its anatomical structure, horny jaws, and long intestine, is incorrect. Recent observations have shown that animal matter is preferred to vegetable; all food must be in a state of maceration, especial fondness for dead animals being shown.

Respiration is at first carried on by means of external gills. They are soon replaced by internal structures covered by opercula.

Rapidity of development depends upon the abundance of food and the temperature of water. The most favorable conditions are a shallow pool, readily warmed by the sun and well stocked with organic matter, that is, an old pond. In this stage the frogs may reach a length of several inches, the bullfrog tadpole being largest. The various species closely resemble each other, but can be distinguished after some experience by certain points of mouth structure, size, and coloration.

In a period varying from two months to two years the first indication of the adult form appears in the protrusion of the two hind legs. The forelegs or arms, owing to their being concealed by the gill membranes, are much later in coming out.

As the legs become functional the tail is absorbed and furnishes material for growth, so that little food is taken. In the case of the second-year tadpole the capture of insects is begun before the tail is

lost. As the gills are replaced by lungs during this period, it is essential that the tadpoles have access to land or resting-places, and it is a time of peculiar difficulty in the creature's existence. When the tail is almost fully resorbed, the purely aquatic life is forsaken for the amphibious and the food is changed from dead to living matter, which must demonstrate its living condition by motion. The peculiarly formed tongue—loose behind, so that it may be thrown out to quite a distance—is covered with a viscid secretion so that the frog readily captures any insects or small animals that approach it closely. Tadpoles are commonly satisfied to wait patiently for their food, and even the adults do not often search actively for food. Sexual maturity is reached in about three or four years, being latest for those varieties that pass the first winter in the tadpole stage. It is generally believed that frogs live for 12, 15, or even 20 years.

During the tadpole stage they furnish tempting morsels for fish, reptiles, some mammals, and other frogs, and especially for wading birds, like herons and cranes. Their defenseless condition and the shallowness of their natural habitats at this period make them ready prey,

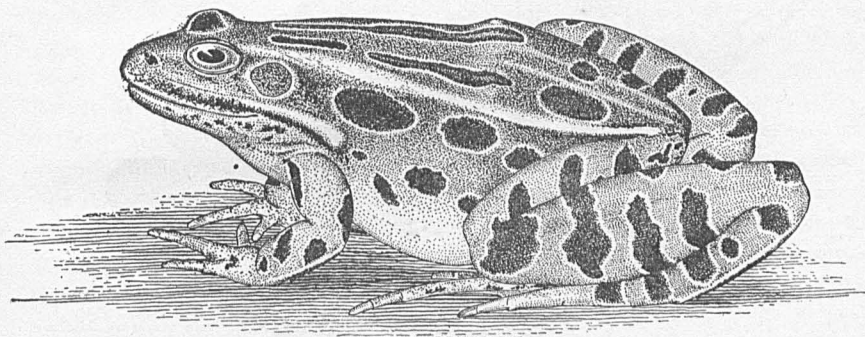

Spring Frog or Leopard Frog (*Rana virescens*).

and it is in the prevention of this wholesale destruction that man may profitably intervene. In the adult frog stage the relentless pursuit by birds and reptiles is continued until of the hundreds of eggs deposited few become reproducing individuals. Only slight revenge for all this slaughter can be taken. They may occasionally capture disabled fish or small fish of sluggish habits found in the mud or on the bottom, and instances are recorded of their eating snakes, toads, and young birds, but insects and lower forms are their staple diet.

DESCRIPTIONS OF MARKETABLE FROGS OF THE UNITED STATES.

The species of frogs commonly eaten are the bullfrog (*Rana catesbiana*), the green frog (*Rana clamata*), the spring frog (*Rana virescens*), and the western bullfrogs (*Rana pretiosa* and *Rana aurora*).

The following references to their geographical distribution and brief descriptions of their color and form have mainly been extracted from Professor Cope's work on *The Batrachia of North America* (Bulletin No. 34, U. S. National Museum, 1889).

The most widely distributed species is the common frog, spring frog, shad frog, or leopard frog (*Rana virescens*). It is found from the Atlantic Coast to the Sierra Nevada Mountains, and from Lake Athabasca, in Canada, to Guatemala, Central America, but is most abundant in the Eastern States. It reaches a length of about $3\frac{1}{2}$ inches, exclusive of legs. The toes are well webbed, but the web does not reach the tips of the fourth toe, as in the common bullfrog. The head is moderate in size, the snout being rather pointed; the tympanum (ear) is distinct and nearly as large as the eye. The hind limb being carried forward along the body, the tibio-tarsal articulation reaches nearly the tip of the snout. The color is usually bright green, marked by irregular black, dark-brown, or olive blotches edged with whitish or yellowish. These spots form two irregular rows on the back and one or two more or less

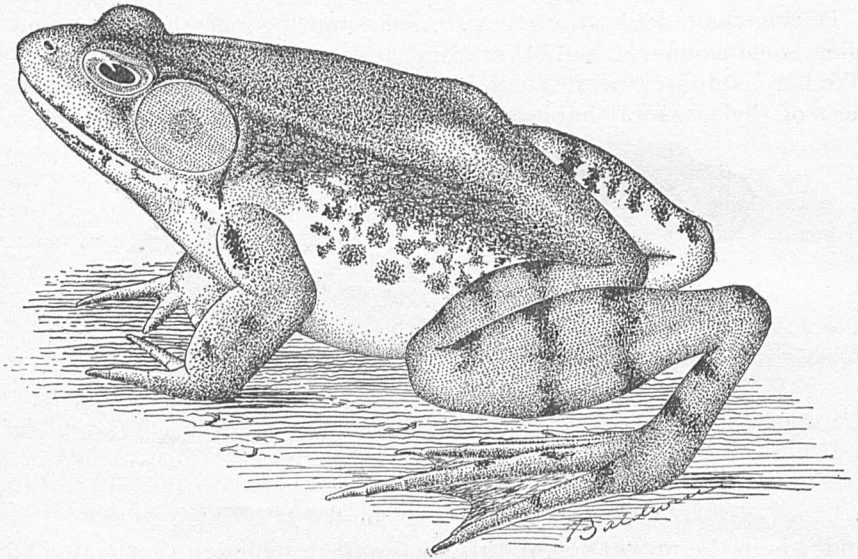

Green Frog or Spring Frog (*Rana clamata*).

indefinite rows on the sides. The blotching is continued as spots or bars on the posterior extremities. These spots are frequently smaller and more numerous than shown in the specimen figured. The glandular fold which runs from the orbit to the posterior part of the body is yellow. The under surface is whitish or light yellow and unspotted. The leopard frog passes the tadpole stage the first season, and is more gregarious than the bullfrog or green frog. These considerations are of importance from a culturist's standpoint.

The green frog or spring frog (*Rana clamata*) is found throughout the Eastern and Central States and neighboring parts of Canada. The body and limbs are stout and massive, the legs are short, and the head is more rounded than in *R. virescens*. The tympanum is very large, though this differs in the sexes, as a rule being larger than the eye in

males and smaller in females. A fold of skin runs from the eye backward, with a short branch from the tympanum to the shoulder. The femur and tibia are equal in length, the web of toes not reaching end of fourth toe.

The color above is dark olive posteriorly, passing into brilliant green anteriorly. It is sometimes greenish-brown above and on sides, with small round brown spots. The buttocks are usually mottled with brown and yellowish white, but are almost uniformly black in some specimens. Below, this species, white or greenish white, sometimes more or less mottled and blotched. The throat is citron yellow.

This frog is especially aquatic in habits, not hunting on land; it frequents all kinds of fresh waters. It is more solitary in its habits than *R. virescens*, living singly, in pairs, or in small companies. It is active on land and in water, but not noisy. A nasal "chung" is occasionally uttered. When disturbed it often emits a shrill cry as it leaps into

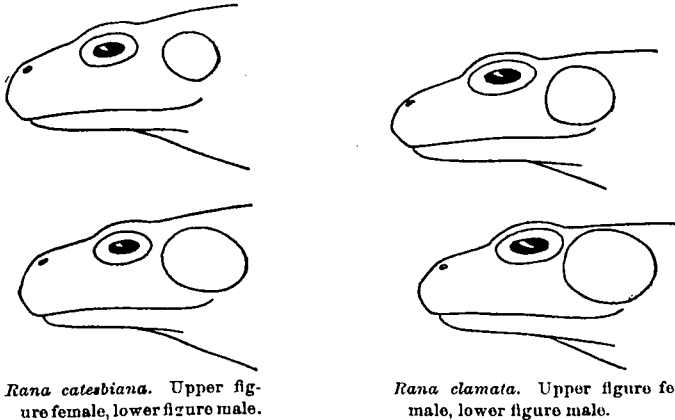

Rana catesbiana. Upper figure female, lower figure male.

Rana clamata. Upper figure female, lower figure male.

Figures illustrating relative size of the tympanum in the two sexes.

the water. It is preeminently an inhabitant of swamps and marshes, especially those connected with rivers or large creeks. "It is the first species heard in spring, and although its voice is not loud, the noise produced by thousands of them is deafening when heard close at hand, and is transmitted through the atmosphere for many miles. It may be imitated by the syllables *chock, chock, chock.*"

The pickerel frog, marsh frog, or tiger frog (*Rana palustris*) closely resembles the leopard frog, but may be readily distinguished from it by the bright yellow on the thighs and legs. It is solitary in its habits and is often found in the grass, although preferring cold spring streams. In the Alleghany Mountains it is the most abundant frog. It is a very active species, taking longer leaps than any of the others here mentioned. The note is a prolonged, low, grating croak. Owing to its disagreeable odor it is but rarely eaten.

The bullfrog (*Rana catesbiana*) is the largest of North American frogs, reaching a body length of over 8 inches. It has much the same geographical range as the spring frog. The body is very bulky and clumsy, the legs are thick, and the head is broader than in *R. clamata*. A fold of skin extends from the eyes over the tympanum, around the insertion of forearm, and disappears on the breast. There are no folds on the sides of back, as in *R. clamata* and *R. virescens*. The skin is slightly rough above. The tympanum is larger than eye, with the same sexual differences as in *R. clamata*. The tibia is slightly shorter than the femur. The hind toes are fully webbed. The complete webbing of the fourth toe, with the absence of dorsal folds of skin, furnishes means of distinguishing this from the spring frog.

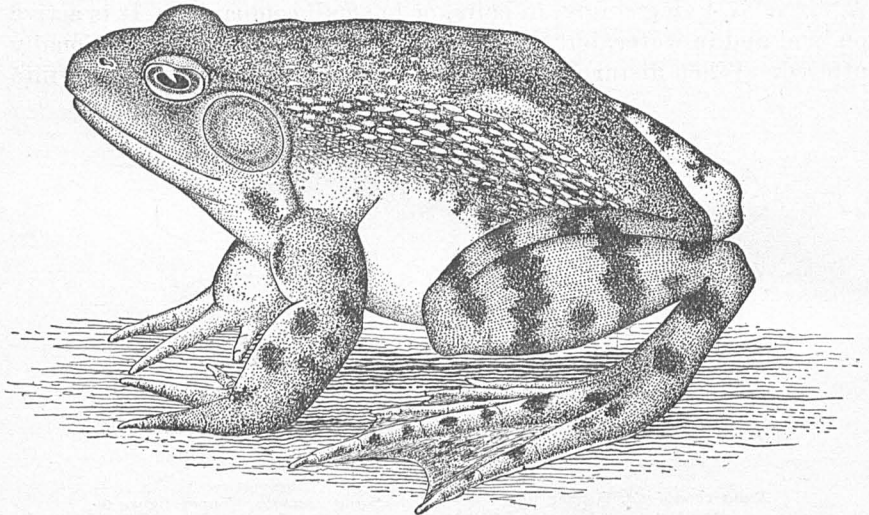

Common Bullfrog (*Rana catesbiana*). Male.

The color above is olivaceous, brown, or ferruginous, with darker blotches half the diameter of the eye, more or less uniformly distributed. The color is sometimes yellowish green without blotches or other markings. The hind legs are barred above and the buttocks blotched with nearly black markings. The lower parts are white, with obscure mottlings of brown, the throat sometimes being bright yellow. In the young the blotches above are reduced to distinct black dots, and the under parts are yellowish anteriorly. The habits are much the same as those of *R. clamata*. Both species pass the first winter in the tadpole stage and are said under unfavorable circumstances to pass even the second winter so. This fact, with the solitary habits of the adult, is of importance to the culturist.

The Western frogs are not well known. The range of *Rana pretiosa* is from Montana west to Puget Sound, thence south to southern California. It is the common frog of the Northwestern States. The body is stout and depressed like *R. catesbiana*. The head is obtuse, rounded, subtruncate, and broader than long. The eyes are small and the

tympanum, which is sometimes indistinct in some small specimens, is smaller than the eye. Skin thick. The femur is shorter than the tibia and not quite half length of body. The toes are fully webbed. A depressed ridge extends from eye to flank. The color is dull yellowish-

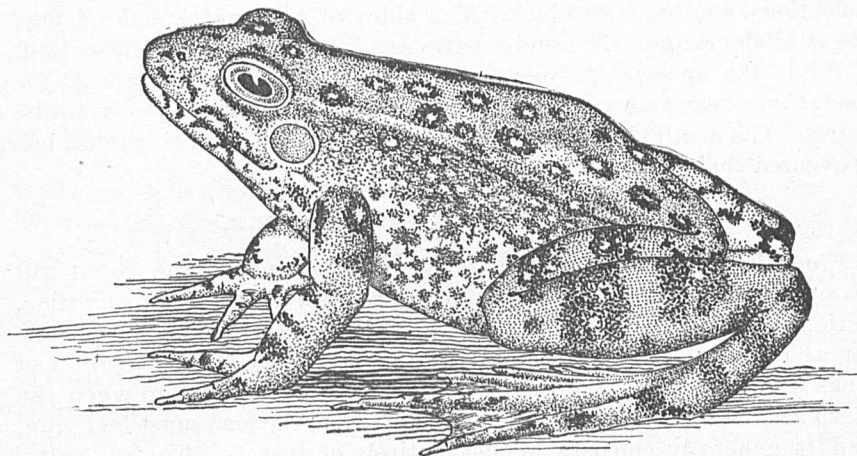

Western Frog (*Rana pretiosa*).

brown (dead leaf) above, darker on sides, with circular brown blotches between the ridges. The outer surface of the limbs is blotched transversely. The body spots are often less numerous and smaller than in the specimen figured. The under parts are yellowish white, with obscure brown marbling, posteriorly salmon color.

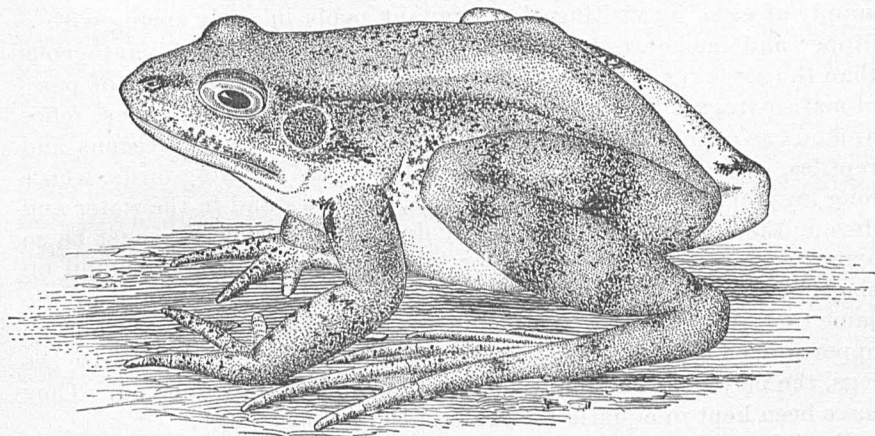

Western Bullfrog (*Rana aurora*).

Rana aurora is found in the western coast region of the United States. The body is depressed and elongated; limbs slender, well developed; head broad, acute, rounded anteriorly; eye moderate; tympanum smaller than eye, but not so small as in preceding species. A fold of

skin runs from eye to hind leg. The femur is shorter than the tibia, which is rather more than half the length of body. The toes are not quite fully webbed, the last joints of all the toes and last two of the fourth toe being free. The color above is greenish-yellow, with golden reflections, spotted with black. The sides of abdomen and hind legs are reddish-orange. The under parts are dull yellowish-green, spotted.

While the species of frogs described are those commonly used for food, there seems no valid reason why any of the *Ranidae* may not be eaten. The small size of some, with possibly a disagreeable odor, has prevented their use up to this time.

SUGGESTIONS FOR FROG-CULTURE.

From the foregoing discussion of the development of the frog it will be seen that its culture must be of necessity a matter requiring time, patience, and an appreciation of the animal's habits and needs. So far as can be learned, attempts thus far made in the cultivation of frogs from the egg stage have been arrested at the period when the larva assumes the adult form. From this time the food must be living, and it generally consists almost entirely of insects. The difficulty, approaching impossibility, of furnishing these in sufficient quantity has been the great drawback. The placing about the pond of meat and decaying matter to attract flies has been suggested, but the contamination of the water by the poisonous matters of decomposition has counteracted all benefits produced. The frogs, failing in the supply of more natural food, have been compelled to devour one another.

To rear the tadpole is comparatively easy. Anyone may obtain a supply of eggs by visiting the stagnant pools in early spring with a dipper and bucket, but this method is said to be less advantageous than the stocking of suitable waters with a sufficient number of pairs of mature frogs. The young can be protected by building a close fence around the edge of the pond to exclude such enemies as raccoons and reptiles, while a screen must be provided so that wading birds, whose long legs furnish them special facilities, can not stand in the water and devour the helpless tadpoles. Any device to be effective must be so arranged that there is no room for birds or other animals to stand on shore or in shallow water, either on or under the screen, and at the same time it must allow the young to come to land, for if there is no opportunity for the tadpoles to breathe the air at rest and exercise the legs, the period of metamorphosis will be indefinitely delayed. They have been kept in aquaria for years in the tadpole stage.

Food during this period is readily provided. If a shallow old pond is chosen, already well stocked with organic matter, it will supply, unaided, food for a large number of frogs. This may be readily increased by supplying animal refuse, liver and such material, care being taken, of course, not to leave a surplus to putrefy and infect the water. The more abundant the food and the warmer the water the more rapid is the

growth, hence the desirability of selecting a shallow pond. The young should be separated from the adult frogs during this time, as they are eagerly eaten; and it is needless to say that the pond must be free from fish, turtles, snakes, and crayfish.

The critical period occurs at the time of metamorphosis. The creature is now abandoning its aquatic habits and has not yet a perfect apparatus for terrestrial life. Any slight disarrangement of the natural environment is liable to destroy the equilibrium. The rapid resorption of the tail furnishes matter for growth, so that food is not so much a necessity, but as soon as the terrestrial habit is fully assumed live food is absolutely requisite, and should be furnished in liberal quantities. There seems to be no reason why this might not be accomplished by transfer of the tadpoles to waters where natural food abounds. It is useless to attempt to supply this food artificially by any method at present known, neither has any device to increase the natural abundance of insects been practicable as yet. The pond should have a growth of rushes and other plants; wild rice (*Zizania aquatica*) has been recommended, but it might attract birds that would prefer young frogs and tadpoles to their vegetable fare. Shade is necessary. Such a pond will furnish natural food for a large stock of frogs, and give opportunity for successful breeding.

One of the most successful "frog farms" is in Ontario, in the Trent River basin. It has been in operation about twenty years and annually yields a comparatively large product of frogs. The waters were stocked by means of mature mated frogs. No attempt is made to confine the frogs until near the time for shipment to market. They are then taken alive at night, with the aid of a torchlight, and confined in small pens that can be drained when the frogs are desired for market. No food is given, as this is naturally present in sufficient amount for successful growth. The species is the eastern bullfrog (*Rana catesbiana*); it begins to breed at the age of three years and reaches a marketable size in four years. During the years 1895 and 1896 this "farm" yielded 5,000 pounds of dressed frog legs and 7,000 living frogs for scientific purposes and for stocking other waters.

While at present it would perhaps be advisable to limit practical attempts at frog-culture to stocking natural waters with paired breeders, experiments in artificial methods should not be abandoned. There seems no reason why methods similar to those at present pursued in fish-culture may not eventually be successful in the case of frogs.

OYSTERS AND METHODS OF OYSTER-CULTURE.

BY

H. F. MOORE,
Assistant, U. S. Fish Commission.

CONTENTS.

	Page.		Page.
Introduction	265	Description of natural bed	292
Distribution :		Destruction of natural beds—causes and	
Atlantic coast	265	remedies	295
Pacific coast	266	Increase of supply by artificial means....	296
Description :		Planting with seed :	
Eastern oyster, <i>Ostrea virginiana</i>	266	Preliminary considerations	298
Pacific coast "native," <i>Ostrea lurida</i> ..	267	Preparing bottom	299
Reproduction and development :		Seed	301
Sexual characteristics	267	Sowing the seed	302
Ripening of the generative organs... ..	268	Working the beds	303
Spawning	268	Planting with cultch or stool :	
Embryonic development	270	Preliminary considerations	304
Fixation, set, or spatting	274	Preparing bottom	305
Growth	274	Cultch, collectors, stool	305
Anatomy	276	Coating cultch	309
Physical and biological conditions on oys-		General considerations on spat-col-	
ter-beds :		lecting	310
Temperature of water	280	Working the beds	312
Temperature; planted beds in San		Protection from enemies	313
Francisco Bay	281	Increase on planted beds	320
Density of water; determination of		Growing oysters in ponds	320
density and temperature	281	Breeding oysters in ponds	322
Silt, mud, and suspended matter	283	Artificial propagation	330
Tides and currents	284	Artificial feeding	335
Depth of water	285	Fattening, plumping, floating	336
Weather conditions—storms, gales,		Greening	337
and ice	285	Transportation and length of life when	
Food	286	removed from the water	338
Enemies	288	Notes on clam-culture	339

OYSTERS AND METHODS OF OYSTER-CULTURE.

By H. F. MOORE,
Assistant, United States Fish Commission.

INTRODUCTION.

This paper is designed to briefly set forth the principal facts relating to the subject of oyster-culture in the United States. It embraces the practices of proved commercial value as well as a summary of the methods and results of investigations which appear to give some promise of utility in certain places and under special conditions, or which indicate the lines along which profitable experiment may be carried on. It is intended primarily as a guide to those persons who are exhibiting an interest in the subject and who contemplate embarking in the industry, yet hesitate on account of unfamiliarity with the methods employed. To aid such persons to a more thorough understanding of the problem involved, certain matters are considered which do not strictly appertain to the practical side of the subject, but which may assist in explaining observed phenomena or in indicating the limitations and possibilities of experiment. Such are the chapters on development and anatomy.

Attention is directed chiefly to the eastern oyster, which is the species of principal, one might almost say only, interest in this country, and, practically, the great problem of oyster-culture applies to it alone. For comparative purposes, however, and to round out the information presented, it has seemed advisable to incorporate some facts regarding the native oysters of the Pacific Coast.

DISTRIBUTION.

ATLANTIC COAST.

Upon the eastern coast of North America there is but one species of oyster, *Ostrea virginiana*, which occurs along the northern side of the Gulf of Mexico, on the Atlantic coast from Florida to Cape Cod, and on the southern and western shores of the Gulf of St. Lawrence. In Massachusetts Bay and on the coast of New Hampshire and Maine it does not now occur, though it was found in abundance locally at the time of the settlement of the country, and the former existence of beds of great extent is indicated by the vast quantities of the valves in the ancient Indian shell-heaps. Oyster fisheries are located in every coast-wise State from Texas to Massachusetts and in the Maritime Provinces,

the most important being in Chesapeake Bay, mainly upon the natural beds, and in Long Island Sound, principally upon planted grounds. The Canadian oyster-beds are much depleted, and an effort is now being made to restore them to a productive condition.

PACIFIC COAST.

Upon the western coast of North America there are five, and perhaps six, recognized species of oysters, but only two of them are of present importance.

The eastern oyster was planted in San Francisco Bay about 1872 and has there formed the basis of a somewhat important industry ever since. The supply has been maintained by the annual planting of seed oysters from the east, and while the species appears to be propagating itself to a limited extent, no reliance has been placed upon this fact for the maintenance of the beds. The United States Fish Commission has recently planted oysters in Willapa Bay, Washington; Yaquina Bay, Oregon, and Humboldt Bay, California, but it is still too early to say with what success.

The native oyster (*Ostrea lurida*) of California, Oregon, and Washington is found at various places on the coasts of the States mentioned, but attains its greatest size and perfection in Willapa Bay. It is much inferior to the eastern oyster in size, but its flavor is esteemed by many.

In the Gulf of California is found a large species, *Ostrea iridescens*, which resembles the eastern species and is an object of some trade in the adjoining portions of Mexico. Attempts have been made to introduce this form in the markets of San Francisco, but the mortality en route has been large and the venture unprofitable.

Two smaller oysters, *Ostrea palumea* and *Ostrea palumea glomerata*, are also found in the Gulf of California.

DESCRIPTION.

EASTERN OYSTER, *OSTREA VIRGINIANA*.

The shell of this species is generally elongate, but varies much with age and the conditions under which it grows. In the younger stages it is often nearly round, with ear-like projections on each side of the hinge and stout radiating ridges near the margin, thus bearing some resemblance to the European oyster. In shells which are actively growing there is a broad fringe of yellow cuticle around the edge of the valves, which, however, soon becomes thickened by a deposit of lime.

The shell is subject to great variation in thickness, but it is rarely so thin as in the Pacific coast oyster. The exterior is marked by laminations and more or less concentric lines of growth; it is often covered by a yellowish cuticle, but is sometimes white and flinty in appearance. The inside of the shell is generally white, somewhat tinged with purple near the margins, and with a more or less pearly luster. The muscular impression is generally nearer to the posterior

margin than to the hinge; it is a well-defined scar, kidney-shaped in specimens of ordinary size, but becoming more elongate in very large individuals; in young specimens it is pale, but it afterwards becomes purple or almost black. The left or lower valve is deeply concave within, the upper valve being flat or, usually, slightly concave. The animal portions are large, nearly filling the shell, and the mantle border is comparatively narrow. (Plate v.)

PACIFIC COAST "NATIVE," *OSTREA LURIDA*.

The shell of this species is thin and irregular, varying in shape from almost round to elongate elliptical; the surface is sometimes laminated, but is never ribbed; the color is variable, being sometimes purple, sometimes dirty green or gray; the inside of the shell is greenish, sometimes tinged with purple. The muscular impression or scar is purple, but paler than in the eastern oyster, and its greatest length is usually longitudinal rather than transverse; it is situated about midway between the hinge and the lips or nibs of the shell, and its ventral margin is usually prolonged toward the hinge. There is rarely a well-defined pit or excavation beneath the hinge, the inner face of the shell sloping off gently from the ligament. The lower valve is deeper than the upper one, but is rarely so strongly concave as in the eastern species. (Plate vi.)

REPRODUCTION AND DEVELOPMENT.

SEXUAL CHARACTERISTICS.

In the European oyster the individuals are hermaphrodites—that is, each is both male and female; in the common eastern oyster the sexes are separate, each individual being either male or female, but not both.

Although the sexes differ remarkably in physiology and minute anatomy, it is not possible to distinguish male from female by any known external characters. It is only by an examination of the genital glands, which in the male produce the spermatozoa or milt and in the female the ova, eggs, or spawn, or by examining the genital products themselves, that the one sex may be distinguished from the other.

The differences between the ovaries of the female and the testes of the male are explained in the section treating of the anatomy. When the animals are ripe, the distinction of the sexes is most conveniently made by an examination of the genital products. A drop of genital fluid is extracted from the oyster in the manner described under the head of artificial fertilization (p. 332) and let fall into a glass of clear sea water. If the individual be a ripe female, the drop will break up into a uniformly distributed cloud, which, if examined against a black background, will be seen to consist of separate minute white granules or eggs. If the eggs be unripe, they will remain aggregated in little compound masses. If the specimen examined be a male, the drop of milt will form an irregular, stringy cloud, showing a tendency to drift in

streaks if the water be agitated, and with no particles distinguishable by the naked eye.

Another test is to spread out a drop of the genital fluid, mixed with a drop of water, in a thin film upon a piece of glass, such as a microscope slide. If the specimen be a female, an examination with a strong hand lens will reveal many minute pear-shaped or oval bodies or eggs, each with a clear spot, the nucleus or so-called germinal vesicle. If the specimen be a male, the film can not be resolved into distinguishable particles when viewed with the lens, but consists of a milk-white mass, having a quivering appearance owing to the effect of the combined movements of the indistinguishable spermatozoa.

The histological characters which distinguish the testes and ovary are considered under the head of anatomy.

According to Professor Schiedt, an hermaphroditic oyster occurs on our northwest coast, the specimens examined coming from the State of Washington, the exact locality not being mentioned. Sexually, therefore, this species resembles the common oyster of Europe.

RIPENING OF THE GENERATIVE ORGANS.

In spring, when the water begins to warm, certain changes begin to manifest themselves in the generative organs, preparatory to the act of spawning. In the female some of the minute eggs in the ovaries increase in size and become loosened in the follicles or little pockets of tissue in which they have undergone their early development. All of the eggs which are to be discharged in any one year do not ripen at the same time, so that the spawning of each individual extends over a greater or less period. An examination of the ovary at any time will always show great numbers of minute immature eggs, most of these being ova which will ripen and be discharged during some subsequent year. Other changes, which it is not necessary to mention here, take place in the eggs and tissues, but the ultimate result is that the ovary becomes enlarged by the growth of the ripening eggs and the latter pass into the oviducts, which stand out as milky-white and much-branched vessels on each side of the body.

The spermatozoa develop in somewhat the same manner, but the generative cells, instead of developing into eggs, undergo rapid division, each into a number of minute active bodies, which pass into the sperm ducts and gorge them with a white fluid, the milt, in general naked-eye appearance closely resembling the ovarian fluid.

SPAWNING.

The act of spawning consists in the discharge of the ripe genital products into the surrounding water, where fertilization is left to chance.

The genital ducts, one on each side, open into the chambers above the gills, and the ova in the one sex and the spermatozoa in the other, gradually oozing out of the openings, are caught up by the currents of water passing through the gill-canals and expelled from the body,

together with the various waste products resulting from digestion and respiration. •

The season at which oysters spawn differs with the latitude of the bed and with local conditions. As a general rule, it may be said that they ripen earlier in the south than in the north, and that in the same region the genital products mature earlier in shallow than in deep water. These facts appear to be dependent primarily upon the temperature, other things being equal, southern waters warming before the northern, and the shallows before the depths.

It is stated that the raccoon oyster of South Carolina spawns from the middle of March to the middle of August. Ripe individuals are found in shallow-water creeks during January and February, and it is probable that intermittent spawning may take place at any time during the year when favorable conditions prevail. In Chesapeake Bay oysters are found spawning from April to October, but apparently a few scattered individuals spawn at other times, though most of the spawn appears to be cast during the latter part of July or early in August. In Long Island Sound spawning takes place, according to the locality, during May, June, July, and August. Sometimes many oysters are found with well-developed ova during April, but this appears to be unusual, and Dr. Dean remarks that when it occurs "it will almost invariably be found that the spring has been warm and dry."

Not only the time of spawning, but the quantity of spawn, appears to be affected by the weather conditions. Sudden changes produce very marked results, and a transfer of the oyster from one place to another during the spawning season is almost certain to interfere with reproduction or even absolutely arrest it.

The age at which the oyster becomes capable of reproducing its kind varies with the locality, but it appears that in regions of rapid growth the generative organs ripen during the first year. The number of eggs discharged by the female is naturally dependent upon its size. According to Dr. Brooks, the Maryland oyster of average size produces 16,000,000 eggs each year, while a very large individual may produce 60,000,000. The spermatozoa, being extremely minute, are present in the milt in inconceivable numbers.

Notwithstanding the great fecundity of the individual oyster the reproductive power of the beds is not so vast as is generally supposed. If the oysters are scattered, or the number spawning at a given time is small, most of the genital matter will be wasted, as the contact of the male and female cells is entirely dependent upon chance, and the fewer such cells there are in a given body of water the smaller the probability of their meeting and fusing in the manner constituting the act of fertilization. Neither the eggs nor the spermatozoa live long after they are discharged from the parent, and if fertilization is to take place at all the two elements must be brought into contact promptly; and it will be seen, therefore, that nature must supply a vast number of germ cells to insure the survival of but a few.

EMBRYONIC DEVELOPMENT.

The following popular account of the early stages in the development of the oyster is slightly modified from the description by Dr. W. K. Brooks:

The ovarian eggs are simply the cells of an organ of the body, the ovary, and they differ from the ordinary cells only in being much larger and more distinct from each other, and they have the power, when detached from the body, of growing and dividing up into cells, which shall shape themselves into a new organism like that from whose body the egg came. Most of the steps in this wonderful process may be watched under the microscope, and owing to the ease with which the eggs of the oyster may be obtained this is a very good egg to study.

About 15 minutes after the eggs are fertilized they will be found to be covered with male cells, as shown in plate VII, fig. 1.* In about an hour the egg will be found to have changed its shape and appearance. It is now nearly spherical, as shown in plate VII, fig. 2, and the germinative vesicle is no longer visible. The male cells may or may not still be visible upon the outer surface. In a short time a little transparent point makes its appearance on the surface of the egg and increases in size and soon forms a little projecting transparent knob—the *polar globule*—which is shown in plate VII, fig. 3, and in succeeding figures.

Recent investigations tend to show that while these changes are taking place one of the male cells penetrates the protoplasm of the egg and unites with the germinative vesicle, which does not disappear but divides into two parts, one of which is pushed out of the egg and becomes the polar globule, while the other remains behind and becomes the *nucleus* of the developing egg, but changes its appearance so that it is no longer conspicuous. The egg now becomes pear-shaped, with the polar globule at the broad end of the pear, and this end soon divides into two parts, so that the egg (plate VII, fig. 4) is now made of one large mass and two slightly smaller ones, with the polar globule between them.

The later history of the egg shows that at this early stage the egg is not perfectly homogeneous, but that the protoplasm which is to give rise to certain organs of the body has separated from that which is to give rise to others.

The upper portion of the egg soon divides up into smaller and smaller spherules, until at the stage shown in plate VII, figs. 5, 6, and 7, we have a layer of small cells wrapped around the greater part of the surface of a single large spherule, and the series of figures shows that the latter is the spherule which is below in plate VII, fig. 4. This spherule now divides up into a layer of cells, and at the same time the egg, or rather the embryo, becomes flattened from above downward and assumes the shape of a flat oval disk. Plate VII, figs. 10 and 9, are views of the upper and lower surface of the embryo at about this time. In a sectional view, plate VII, fig. 11, it is seen to be made of two layers of cells, an upper layer of small transparent cells, *e c*, which are to form the outer wall of the body and which have been formed by the division of the spherules which occupy the upper end of the egg in plate VII, fig. 6, and a lower layer of much larger, more opaque cells, *g*, which are to become the walls of the stomach, and which have been formed by the division of the large spherule, *a*, of plate VII, fig. 6.

This layer is seen in the section to be pushed in a little toward the upper layer, so that the lower surface of the disk-shaped embryo is not flat, but very slightly concave. This concavity is destined to grow deeper until its edges almost meet, and it is the rudimentary digestive cavity. A very short time after this stage has been reached, and usually within from two to four hours after the eggs were fertilized, the embryo undergoes a great change of shape and assumes the form which is shown in three different views in plate VII, figs. 12, 13, 14, and 15.

* References to figures in quoted portions of this paper do not correspond with the originals, being altered to accord with their sequence in the present article.

A circular tuft of long hairs or cilia has now made its appearance at what is thus marked as the anterior end of the body, and as soon as these hairs are formed they begin to swing backward and forward in such a way as to constitute a swimming organ, which rows the little animal up from the bottom to the surface of the water, where it swims around very actively by the aid of its cilia. This stage of development, plate VII, fig. 12, which is of short duration, is of great importance in raising the young oysters, for it is the time when they can best be siphoned off into a separate vessel and freed from the danger of being killed by the decay of any eggs which may fail to develop. On one surface of the body at this stage, the dorsal surface, there is a well-marked groove, and when a specimen is found in a proper position for examination the opening into the digestive tract is found at the bottom of this groove. Plate VII, fig. 13, is a sectional view of such an embryo. It is seen to consist of a central cavity, the digestive cavity, which opens externally on the dorsal surface of the body by a small orifice, the primitive mouth, and which is surrounded at all points, except at the mouth, by a wall which is distinct from the outer wall of the body. Around the primitive mouth these two layers are continuous with each other.

The way in which this cavity, with its wall and external opening, has been formed will be understood by a comparison of plate VII, fig. 13, with plate VII, fig. 8. The layer which is below in plate VII, fig. 8, has been pushed upward in such a way as to convert it into a long tube, and at the same time the outer layer has grown downward and inward around it, and has thus constricted the opening. The layer of cells which is below in plate VII, fig. 8, thus becomes converted into the walls of the digestive tract, and the space which is outside and below the embryo, in plate VII, fig. 8, becomes converted into an inclosed digestive cavity, which opens externally by the primitive mouth.

This stage of development, in which the embryo consists of two layers, an inner layer surrounding a cavity which opens externally by a mouth-like opening, and an outer layer which is continuous with the inner around the margins of the opening, is of very frequent occurrence, and it has been found, with modifications, in the most widely separated groups of animals, such as the starfish, the oyster, and the frog; and some representatives of all the larger groups of animals, except the protozoa, appear to pass during their development through a form which may be regarded as a more or less considerable modification of that presented by our embryo oyster. This stage of development is known as the *gastrula* stage.

The edges of the primitive mouth of the oyster continue to approach each other and finally meet and unite, thus closing up the opening, as shown in plate VII, fig. 16, and leaving the digestive tract without any communication with the outside of the body, and entirely surrounded by the outer layer. The embryo shown in plate VII, figs. 12 and 16, are represented with the dorsal surface below, in order to facilitate comparison with the adult, but in plate VII, fig. 17, and most of the following figures, the dorsal surface is uppermost, for more ready comparison with the adult.

In other lamellibranchs, and doubtless also in the oyster, the shell begins as a deposit in an invagination or pocket on the dorsal side of the body. In its manner of formation this shell-gland resembles the primitive mouth for which it has been more than once mistaken by investigators. In some forms the shell is at first single, but in the oyster they are said to be separated from each other from the beginning, and appear independently. Dr. Brooks says further:

Soon after they make their appearance, the embryos cease to crowd to the surface of the water and sink to various depths, although they continue to swim actively in all directions, and may still be found occasionally close to the surface. The region of the body which carries the cilia now becomes sharply defined, as a circular projecting pad, the *velum*, and this is present and is the organ of locomotion at a much later stage of development. It is shown at the right side of the figure in plate VII,

fig. 17, and in plate VII, fig. 18, it is seen in surface view, drawn in between the shells, and with its cilia folded down and at rest, as they are seen when the little oyster lies upon the bottom.

The two shells grow rapidly, and soon become quite regular in outline, as shown in plate VII, fig. 17, and plate VIII, fig. 1, but for some time they are much smaller than the body, which projects from between their edges around their whole circumference, except that along a short area, the area of the hinge upon the dorsal surface, where the two valves are in contact.

The two shells continue to grow at their edges, and soon become large enough to cover up and project a little beyond the surface of the body, as shown in plate VIII, fig. 1, and at the same time muscular fibers make their appearance and are so arranged that they can draw the edge of the body and the velum in between the edges of the shells in the manner shown in plate VII, fig. 18. In this way that surface of the body which lines the shell becomes converted into the two lobes of the mantle, and between them a mantle cavity is formed, into which the velum can be drawn when the animal is at rest. While these changes have been going on over the outer surface of the body other important internal modifications have taken place. We left the digestive tract at the stage shown in plate VII, fig. 16, without any communication with the exterior.

Soon the outer wall of the body becomes pushed inward to form the true mouth, at a point (plate VII, fig. 17) which is upon the ventral surface and almost directly opposite the point where the primitive mouth was situated at an earlier stage. The digestive cavity now becomes greatly enlarged and cilia make their appearance upon its walls, the mouth becomes connected with the chamber which is thus formed and which becomes the stomach, and minute particles of food are drawn in by the cilia and can now be seen inside the stomach, where the vibration of the cilia keep them in constant motion. Up to this time the animal has developed without growing, and at the stage shown in plate VII, fig. 16, it is scarcely larger than the unfertilized egg, but it now begins to increase in size. The stages shown in plate VIII, fig. 1, and plate VII, fig. 18, agree pretty closely with the figures which the European embryologists give of the oyster embryo at the time when it escapes from the mantle chamber of its parent. The American oyster reaches this stage in from twenty-four hours to six days after the egg is fertilized, the rate of development being determined mainly by the temperature of the water.

Soon after the mantle has become connected with the stomach this becomes united to the body wall at another point a little behind the mantle, and a second opening, the *anus*, is formed. The tract, which connects the *anus* with the stomach, lengthens and forms the intestine, and soon after the sides of the stomach become folded off to form the two halves of the liver, as shown in plate VIII, fig. 1. Various muscular fibers now make their appearance within the body, and the animal assumes the form shown in plate VIII, fig. 1, and plate VII, fig. 18.*

What follows this stage may be best told in the words of Professor Huxley, who speaks of the European oyster, in which the metamorphosis from the free-swimming fry to the fixed spat and finally the adult oyster is essentially the same as in our species.

The young animal which is hatched out of the egg of the oyster is extremely unlike the adult, and it will be worth while to consider its character more closely than we have hitherto done.

Under a tolerably high magnifying power the body is observed to be inclosed in a transparent but rather thick shell (plate VIII, fig. 2, *L*), composed, as in the parent, of two valves united by a straight hinge, *h*. But these valves are symmetrical and similar in size and shape, so that the shell resembles that of a cockle more than it does that of an adult oyster. In the adult the shell is composed of two substances

*Report Maryland Fish Commission, Annapolis, 1860, pp. 19-25, in part.

of different character, the outer brownish, with a friable prismatic structure, the inner dense and nacreous. In the larva there is no such distinction, and the whole shell consists of a glassy substance devoid of any definite structure.

The hinge line answers, as in the adult, to the dorsal side of the body. On the opposite or ventral side the wide mouth *m* and the minute vent *v* are seen at no great distance from one another. Projecting from the front part of the aperture of the shell there is a sort of outgrowth of the integument of what we may call the back of the neck into a large oval thick-rimmed disk termed the *velum*, *vl*, the middle of which presents a more or less marked prominence. The rim of the disk is lined with long vibratile cilia, and it is the lashing of these cilia which propels the animal, and, in the absence of gills, probably subserves respiration. The funnel-shaped mouth has no palps; it leads into a wide gullet, and this into a capacious stomach. A sac-like process of the stomach on either side (the left one, *l*, only is shown in fig. 2) represents the "liver." The narrow intestine is already partially coiled on itself, and this is the only departure from perfect bilateral symmetry in the whole body of the animal. The alimentary canal is lined throughout with ciliated cells, and the vibration of these cilia is the means by which the minute bodies which serve the larva for food are drawn into the digestive cavity.

There are two pairs of delicate longitudinal muscles, *rs ri*, which are competent to draw back the ciliated velum into the cavity of the shell, when the animal at once sinks. The complete closure of the valves is effected, as in the adult, by an adductor muscle, *am*, the fibers of which pass from one valve to the other. But it is a very curious circumstance that this adductor muscle is not the same as that which exists in the adult. It lies, in fact, in the forepart of the body and on the dorsal side of the alimentary canal. The great muscle of the adult, fig. 3, *M*, on the other hand, lies on the ventral side of the alimentary canal and in the hinder part of the body. And as the muscles, respectively, lie on opposite sides of the alimentary canal, that of the adult can not be that of the larva, which has merely shifted its position; for in order to get from one side of the alimentary canal to the other it must needs cut through that organ; but as in the adult no adductor muscle is discoverable in the position occupied by that of the larva or anywhere on the dorsal side of the alimentary canal, while on the other hand there is no trace of any adductor on the ventral side in the larva, it follows that the dorsal or anterior adductor of the larva must vanish in the course of development, and that a new ventral or posterior adductor must be developed to play the same part and replace the original muscle functionally, though not morphologically.

* * * * *

When the free larva of the oyster settles down into the fixed state, the left lobe of the mantle stretches beyond its valve, and, applying itself to the surface of the stone or shell to which the valve is to adhere, secretes shelly matter, which serves to cement the valve to its support. As the animal grows the mantle deposits new layers of shell over its whole surface, so that the larval shell valves become separated from the mantle by the new layers (plate VIII, fig. 3, *S*), which crop out beyond their margins and acquire the characteristic prismatic and nacreous structure. The summits of the outer faces of the umbones thus correspond with the places of the larval valves, which soon cease to be discernible. After a time the body becomes convex on the left side and flat on the right; the successively added new layers of shell mold themselves upon it, and the animal acquires the asymmetry characteristic of the adult.*

The horny convex shell of the fry (plate VIII, fig. 3, *L*) may be seen, for a considerable time after attachment, at the umbo or beak of the developing shell of the spat (plate VIII, fig. 3, *S*). The under or attached valve of the latter at first conforms closely to the surface to which it has become

* Huxley, Thomas H. Oysters and the Oyster Question. The English Illustrated Magazine, London, Oct. 1883 and Nov. 1883, vol. 1, pp. 47-55, and pp. 112-121.

attached, being usually flat, but afterwards, as a rule, becoming deep and strongly concave, through an upgrowing along the edges.

FIXATION, SET, OR SPATTING.

At the time of fixation the fry will, under proper conditions, attach itself by its left valve to any hard or firm body with which it may come in contact.

The first essential is that the surface should be clean and that it should remain so a sufficient length of time to enable the young oyster to firmly establish itself. So long as this condition obtains, the nature of the material seems to matter but little. In most bodies of water the spat fixes itself at all levels from the surface to the bottom, but in certain parts of the coast its place of attachment is confined to the zone between high and low water, the mid-tide mark being the place of maximum fixation. It has been suggested that this was due to the density of the water preventing the sinking of the fry. There are a number of objections to this theory, but no better one has been offered, and it may receive provisional acceptance.

GROWTH.

At the time of its attachment the oyster fry measures about one-eighth or one-ninth of an inch in diameter. The valves of the shell are strongly convex and symmetrical, and are composed of a horny material quite different from the finished shell of the adult.

The mantle, a thin flap of tissue which envelops the body of the oyster on each side, projects freely from between the lips of the valves and is the organ which secretes the shell. Upon its outer surface successive layers of horny material are laid down, these becoming impregnated with calcareous matter arranged in a prismatic manner, and thus forming the stony shell which characterizes the adult.

The mantle increases *pari passu* with the growth of the soft parts in general, and as it is always capable of protrusion a little beyond the lips of the valves, it follows that each successive layer of shell is slightly larger than that which preceded it, and the shell increases in length and breadth as well as in thickness. From the nature of its growth, therefore, the youngest or newest part of the shell is on the inner face and at the edges, the latter always being sharp and thin in a growing oyster. The shell of the young oyster is always thin and delicate, and is generally more rounded than in the adult. The lower valve at first adheres closely to the body to which it is attached, but later its edge grows free and the valve, as a whole, becomes deeper and more capacious than its fellow. The small larval or fry shell remains visible at the beak of the spat shell for a considerable time, but becomes eroded away before the oyster reaches the adult condition.

The soft parts of the oyster assume their adult form in general soon after attachment, although the genital glands do not become functional until a much later period.

The rate of growth (plates X, XI, XII, XIII) varies with locality and conditions. It is more rapid when food is abundant and at seasons when the oyster is feeding most vigorously, these conditions being filled most thoroughly in summer and fall, when the warm water increases the vital activities of both oyster and food.

In South Carolina oysters not more than six or seven months old were found to have reached a length of $2\frac{1}{2}$ inches, and in the warm sounds of North Carolina they reach a length of $1\frac{1}{2}$ inches in from two to three months. In the coves and creeks of Chesapeake Bay they attain about the same size by the end of the first season's active growth, and by the time they are two years old they measure from $2\frac{1}{2}$ to $3\frac{3}{4}$ inches long and from 2 to 3 inches wide. On the south side of Long Island the growth of the planted oysters is much more rapid than in Connecticut, it being stated that "two-year plants" set out in spring are ready for use in the following fall, while upon the Connecticut shore it would require two or three years to make the same growth. On the south side of Long Island oysters $1\frac{3}{8}$ inches long in May have increased to 3 inches by November of the same year.

The amount of lime in the water is a factor in determining the character of the shell, and oysters growing in waters deficient in that respect have thinner shells than those which are well supplied, and are therefore more susceptible to the attacks of the drill.

The shape of the oyster to a certain extent determines its value in the market. Single oysters of regular shape with deep shells and plump bodies will bring a better price than those which are irregular and clustered. The shape depends largely upon the degree of crowding to which the oyster has been subject. When numerous spat become attached to a single piece of cultch, such as an oyster shell, there is often insufficient room for the development of all. Many will be crowded out and suffocated, while the survivors will be distorted through the necessity of conforming to the irregular spaces between the valves of their fellows. Sometimes the pressure exerted between the rapidly growing shells is sufficient to break up the more fragile forms of cultch, and the separated oysters then usually improve somewhat in shape.

The crowding of oysters reaches its climax upon the "raccoon" oyster beds. Raccoon oysters are usually found in localities where the bottom is soft and the only firm place which offers itself for the attachment of the spat is upon the shells of its ancestors. Temperature and other conditions are favorable, growth is rapid, the young oysters are crowded into the most irregular shapes, the shells are long, thin, and sharp-edged, and eventually the mass of young is so dense that it crowds out and smothers the preceding generations which produced it and offered means for its attachment. Oysters crowded in this excessive manner are poor-flavored as well as ill-shaped, but both defects are corrected if they be broken apart, as may be readily done, and planted elsewhere.

ANATOMY.

The following popular description of the anatomy of the oyster is extracted from the writings of Professors Brooks and Ryder:

The general structure of an oyster may be roughly represented by a long, narrow memorandum book, with the back at one of the narrow ends instead of one of the long ones. The covers of such a book represent the two shells of the oyster, and the back represents the hinge, or the area where the two valves of the shell are fastened together by the hinge ligament. (Plate I, fig. 1 l.) This ligament is an elastic, dark-brown structure, which is placed in such a relation to the valves of the shell that it tends to throw their free ends a little apart. In order to understand its manner of working, open the memorandum book and place between its leaves, close to the back, a small piece of rubber to represent the ligament. If the free ends of the cover are pulled together the rubber will be compressed and will throw the covers apart as soon as they are loosened. The ligament of the oyster shell tends, by its elasticity, to keep the shell open at all times, and while the oyster is lying undisturbed upon the bottom, or when its muscle is cut, or when the animal is dying or dead, the edges of the shell are separated a little.

The shell is lined by a thin membrane, the mantle (plate I, fig. 1, *mt*), which folds down on each side, and may be compared to the leaf next the cover on each side of the book. The next two leaves of each side roughly represent the four gills, *g*, the so-called "beard" of the oyster, which hang down like leaves into the space inside the two lobes of the mantle. The remaining leaves may be compared to the body or *visceral mass* of the oyster.

Although the oyster lies upon the bottom, with one shell above and one below, the shells are not upon the top and bottom of the body, but upon the right and left sides. The two shells are symmetrical in the young oyster (plate VIII, fig. 2), but after it becomes attached the lower or attached side grows faster than the other and becomes deep and spoon-shaped, while the free valve remains nearly flat. In nearly every case the lower or deep valve is the left. As the hinge marks the anterior end of the body, an oyster which is held on edge, with the hinge away from the observer and the flat valve on the right side, will be placed with its dorsal surface uppermost, its ventral surface below, its anterior end away from the observer, and its posterior end toward him, and its right and left sides on his right and left hands, respectively.

In order to examine the soft parts, the oyster should be opened by gently working a thin, flat knife blade under the posterior end of the right valve of the shell, and pushing the blade forward until it strikes and cuts the strong adductor muscle, *M*, which passes from one shell to another and pulls them together. As soon as this muscle is cut the valves separate a little, and the right valve may be raised up and broken off from the left, thus exposing the right side of the body. The surface of the body is covered by the mantle, a thin membrane which is attached to the body over a great part of its surface, but hangs free like a curtain around nearly the whole circumference. By raising its edge, or gently tearing the whole right half away from the body, the gills, *g*, will be exposed. These are four parallel plates which occupy the ventral half of the mantle cavity and extend from the posterior nearly to the anterior end of the body. Their ventral edges are free, but their dorsal edges are united to each other, to the mantle, and to the body. The space above, or dorsal to the posterior ends of the gills, is occupied by the oval, firm adductor muscle, *M*, the so-called "heart." For some time I was at a loss to know how the muscle came to be called the "heart," but a friend told me that he had always supposed that this was the heart, since the oyster dies when it is injured. The supposed "death" is simply the opening of the shell, when the animal loses the power to keep it shut. Between this muscle and the hinge the space above the gills is occupied

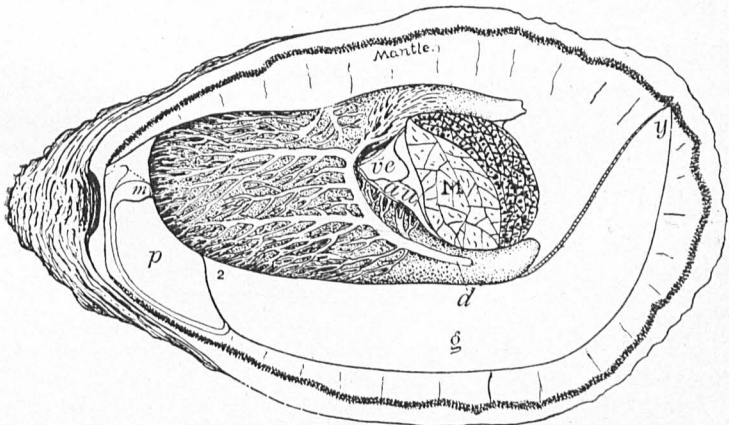
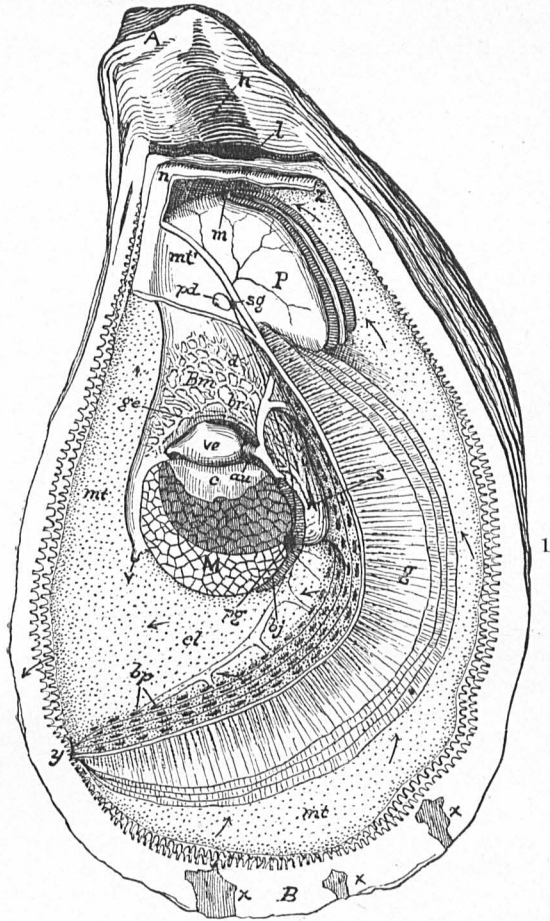

FIG. 1. Oyster with right shell and mantle removed. *a* and *a*, origin of arteries from the ventricle; *au*, auricle of heart; *br*, vessel carrying blood from the gills to the auricle of the heart; *bj*, outline of organ of Bojanus, the so-called kidney; *bp*, pores from which the water issues into the branchial canals; after passing through the gills; *cl*, cloaca; *d*, *pg*, and *sg*, connective and two ganglia of the nervous system; *g*, gills; *gc*, cavity between the two mantle folds; *h*, hinge; *l*, ligament; *M*, adductor muscle; *m*, mouth; *mt*, mantle, the arrows show the direction of currents produced by the cilia; *p*, palps; *p'*, outer end of right pedal muscle; *s*, external opening of sexual and renal organs of right side; *v*, anus; *ve*, ventricle of heart.

FIG. 2. Diagram to show sexual organs of the oyster. *d*, duct of sexual gland. Other letters as above.

by the body, or visceral mass, which is made up mainly of the light-colored reproductive organs and the dark-colored digestive organs, packed together in one continuous mass.

If the oyster has been opened very carefully, a transparent, crescent-shaped space will be seen between the muscle and the visceral mass. This space is the pericardium, and if the delicate membrane which forms its sides be carefully cut away, the heart, *ve* and *au*, may be found without any difficulty lying in this cavity and pulsating slowly. If the oyster has been opened roughly, or if it has been out of water for some time, the rate of beating may be as low as one a minute, or even less, so the heart must be watched attentively for some time in order to see one of the contractions.

In front of the gills, that is, between them and the hinge, there are four fleshy flaps—the lips, *p*, two on each side of the body. They are much like the gills in appearance, and they are connected with each other by two ridges, which run across the middle of the body close to the anterior end, and between these folds is the large oval mouth, *m*, which is thus seen to be situated, not at the open end of the shell, but as far away from it as possible. As the oyster is immovably fixed upon the bottom, and has no arms or other structures for seizing food and carrying it to the mouth, the question how it obtains its food at once suggests itself. If a fragment of one of the gills is examined with a microscope it will be found to be covered with very small hairs, or cilia, arranged in rows, plate VIII, fig. 3, *c*. Each of these cilia is constantly swinging back and forth with a motion something like that of an oar in rowing. The motion is quick and strong in one direction and slower in the other. As all the cilia of a row swing together they act like a line of oars, only they are fastened to the gill, and as this is immovable they do not move forward through the water, but produce a current of water in the opposite direction. This action is not directed by the animal, for it can be observed for hours in a fragment cut out of the gill, and if such a fragment be supplied with fresh sea water the motion will continue until it begins to decay. While the oyster lies undisturbed on the bottom, with its muscle relaxed and its shell open, the sea water is drawn on to the gills by the action of the cilia, for although each cilium is too small to be seen without a microscope, they cover the gills in such great numbers that their united action produces quite a vigorous stream of water, which is drawn through the shell and is then forced through very small openings on the surfaces of the gills into the water tubes inside the gills, and through these tubes into the cavity above them, and so out of the shell again. As the stream of water passes through the gills the blood is aerated by contact with it.

The food of the oyster consists entirely of minute animal and vegetable organisms and small particles of organized matter. Ordinary sea water contains an abundance of this sort of food, which is drawn into the gills with the water, but as the water strains through the pores into the water tubes the food particles are caught on the surface of the gills by a layer of adhesive slime, which covers all the soft parts of the body. As soon as they are entangled the cilia strike against them in such a way as to roll or slide them along the gills toward the mouth. When they reach the anterior ends of the gills they are pushed off and fall between the lips, and these again are covered with cilia, which carry the particles forward until they slide into the mouth, which is always wide open and ciliated, so as to draw the food through the œsophagus into the stomach. Whenever the shell is open these cilia are in action, and as long as the oyster is breathing a current of food is sliding into its mouth.

The cilia and particles of food are too small to be seen without a microscope, but if finely powdered carmine be sprinkled over the gills of a fresh oyster, which has been carefully opened and placed in a shallow dish of sea water, careful observation will show that as soon as the colored particles touch the gills they begin to slide along with a motion which is quite uniform, but not much faster than that of the minute-hand of a watch. This slow, steady, gliding motion, without any visible

cause, is a very striking sight, and with a little care the particles may be followed up to and into the mouth.

In order to trace the course of the digestive organs, the visceral mass may be split with a sharp knife or razor. If the split is pretty near the middle of the body each half will show sections of the short, folded œsophagus, running upward from the mouth, and the irregular stomach, cut 1, *s*, with thick, semi-transparent walls, surrounded by the compact, dark-greenish liver, *ll*. Back of the liver and stomach the convoluted intestine, *i*, will be seen, cut irregularly at several points by the section.

There are no accessory organs of reproduction, and the position, form, and general appearance of the reproductive organ, plate 1, fig. 2, is the same in both sexes. As the reproductive organ has an opening on each side of the body, it is usually spoken of as double, but in the adult oyster it forms one continuous mass, with no trace of a division into halves, and extends entirely across the body and (against) the bends and folds of the digestive tract.*

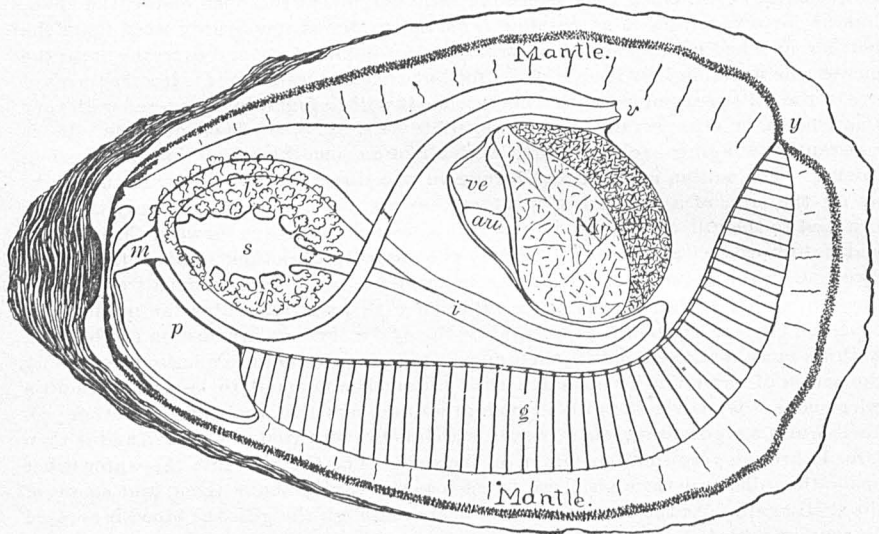

CUT 1.

* The stomach is pretty definitely marked off from the other portions of the digestive tract. It may be said to be that portion of the latter which is surrounded by the liver. The portion of the intestine immediately following the short, widened region which we regarded as the stomach is the most spacious portion of the gut, and in it is lodged a very singular organ, which has been called the "crystalline style." This is an opalescent rod of a glass-like transparency and gelatinous consistence, which measures according to the size of the oyster from half an inch up to one and a half inches in length. Its anterior end is the largest, and in a large specimen measures nearly an eighth of an inch in diameter, but at its posterior end is scarcely half as thick; both ends are bluntly rounded. I fell into an error in supposing that this style was lodged in a special pouch or sac, as described in my report to the Maryland commissioner in 1880. The "crystalline style" really lies in the first portion of the intestine and extends from the pyloric end of the stomach to the first bend of the

* Brooks, W. K. Studies from the Biological Laboratory of Johns Hopkins University, No. 1v, 1888, pp. 5-10 in part.

intestine, where there is a marked constriction of the alimentary canal. It appears, therefore, to be a sort of loose valve in the cavity of the gut; its function may be to prevent coarse particles of food from passing or it may in some way assist digestion. In specimens hardened in acid or alcohol this rod is destroyed, or at least disappears, so that I have been unable to find it. The greater portion of its substance is apparently made up of water.

The peculiar double induplication of the wall of the intestine is described in another place. The fecal matters are extruded in the form of a demi-cylinder, with one side excavated in a groove-like manner. This shape of the fecal matters is due to the presence of the double fold. The feces themselves are composed of extremely fine particles of quartz or sand grains, the tests of diatoms, organic matters, humus, cellulose, fragments of the chitinous coverings of some of the minute worms and articulates, etc., which have been swallowed and digested by the animal. The anus, *v*, is situated on the dorsal side of the great adductor muscle where the intestine ends.

The organs of sensation of the oyster, though not very highly developed, are of sufficient importance to merit attention. The auditory sense, although I have never been able to dissect out the auditory vesicles, I am satisfied exists, because one can not noisily approach an oyster bank where the oysters are feeding without their hearing so that instantly every shell is closed. The tentacles of the mantle are often extended until their tips reach beyond the edges of the valves. If the animal in this condition is exposed to a strong light the shadow of the hand passing over it is a sufficient stimulus to cause it to retract the mantle and tentacles and to close its parted valves. The mantle incloses, like a curtain, the internal organs of the creature on either side, and lies next the shell, and, as already stated, secretes and deposits the layers of calcic carbonate composing the latter. The free edges of the mantle, which are purplish, are garnished with small, highly sensitive tentacles of the same color. These tentacles are ciliated and serve as organs of touch, and also appear to be to some extent sensitive to light.

The nervous system of the oyster is very simple, and, as elsewhere stated, is to some extent degenerate in character. It is composed of a pair of ganglia or knots of nervous matter, plate I, fig. 1, *sg*, which lie just over the gullet, and from these a pair of nervous cords, *d*, pass backward, one on each side, to join the hinder pair which lie just beneath the adductor muscle, *pg*. The mantle receives nerve branches from the hindmost ganglia or knots of nervous matter; these, as their centers, control the contraction and elongation of the radiating bundle of muscular fibers, as well as those which lie lengthwise along the margin; the former contract and withdraw the edges of the mantle from the margin of the shell, while the latter in contracting tend to crimp or fold its edges. The tentacles are mainly innervated by fibers emanating from the hindmost ganglia, while the internal organs are innervated from the head or cephalic ganglia. The hind ganglia also preside over the contractions of the great adductor muscle. The nerve threads which radiate outward from it to the tentacles dispatch the warnings when intruders are at hand that it must contract and close the shells.*

* Ryder, John A.; Fishery Industries of the United States, pp. 714-715.

PHYSICAL AND BIOLOGICAL CONDITIONS ON OYSTER-BEDS.

TEMPERATURE OF WATER.

The oyster lives in waters of widely varying temperature, both as to the average for the year and the extremes met with at different seasons. Perhaps the greatest divergence between the extremes is in Chesapeake Bay, where the range is from the freezing-point of brackish water, something below 32°, to 90° F. In New Jersey and in Chesapeake Bay the shallow-water oysters, which are exposed or nearly exposed at low water, are frequently frozen, an event which is not necessarily fatal if they are gradually thawed. Young oysters in shallow water are sometimes "winter-killed," or their vitality is seriously reduced, by exposure to exceptionally low temperatures. The remedy, or rather preventive, is to remove to deeper water in the fall, and seed oysters on natural spatting-grounds may often be saved by this means.

In deeper water, such as is found on the offshore beds of Long Island Sound, they are not subject to such severe trials, but are nevertheless called upon to withstand, during several months, a temperature not far from 32° F. In the Long Island oyster region the summer temperature of the water reaches 75° F., and from May 1 to November 1 probably never falls below 60° F. On the South Carolina oyster-beds the temperature appears to rarely fall below 55° F., but, on the other hand, the exposed banks of that region are subjected to the direct rays of the sun and therefore withstand a temperature considerably higher than that to which submerged oysters are liable.

The temperature has an important bearing upon the food supply. When the water is warm there is a rapid multiplication of the small forms upon which the oyster feeds, and at the same time the activities of the oyster itself are quickened. The two facts taken together result in a more rapid growth of the oyster than is likely to take place in colder waters.

It is often said that "plants do not spawn," and there appears to be some truth in the statement if we apply it to a period of a year or so after planting, and refer to cases in which the transplanting has induced considerable modification in the conditions under which the oyster is placed. This fact is no doubt largely due to the changes in temperature to which the oyster is subjected when transplanted. Dr. Ryder says:

A very short exposure of the animal to water of an increased temperature caused a deterioration of the generative matter. I have tried to fertilize the eggs of numbers of oysters that had lain over night in the Quinnipiack River and invariably failed; the eggs in every case appeared to be overripe. Oysters taken from the bed at the same time and from the same locality, but kept in a basket over night, gave good results.

The same investigator found that at Beaufort, N. C., the best results in fertilization were obtained the nearer the temperature was to 70° F. Both at Beaufort and in Chesapeake Bay the embryos develop most

rapidly in waters between 74° and 80° F., although the mortality is greater than at a slightly lower temperature. Under such conditions the embryos reach the swimming stage in from 3 to 10 hours, a fact which is, of course, advantageous to those undertaking artificial propagation. When the temperature falls to below 65° F., development almost ceases, and when it rises above 80° F. but few of the embryos reach the swimming stage. Sudden changes are usually fatal, and cold rains kill great numbers of the swimming fry.

Dr. Ryder recommends "that the prevalent temperature of the water during the spawning season shall range from 68 to 80° F." It is quite possible that in other regions, with oysters native thereto, or even those which have been acclimated therein, some other temperature may be found more favorable, but no data bearing upon the matter have been published.

TEMPERATURE; PLANTED BEDS IN SAN FRANCISCO BAY.

The temperature at San Francisco is usually not much higher in summer than in winter, but information upon the subject is limited. Upon the oyster-beds at Millbrae it is said to vary from 58° to 65° F., but at the extreme southern end of the bay it ranges from 67° to 74° F. In October, 1890, Mr. C. H. Townsend found 61° F. at Belmont; at San Mateo, nearer the sea, 60° F., and at California city, 57° F.

In midsummer the temperature was considerably higher; between July 12, 1891, and September 7, 1891, it ranged from 67° to 74° F., the means for 10-day periods during the same time being between 69.1° and 72° F. As Mr. Townsend points out, there is, therefore, a considerable period during the summer when the temperature, in portions of the bay at least, is favorable for spawning of the planted eastern oysters. The portions of the bay near the sea appear to have a temperature several degrees cooler than in the southern portions.

DENSITY OF WATER.

Oysters are found living in water ranging in salinity from 1.002* to 1.025, but the lower densities are always injurious, and prolonged exposure to their influence is fatal to oyster life. It is not possible to profitably maintain oyster-beds in waters where the density falls below 1.007 for any length of time, the oyster, if not killed, becoming poor in quality, pale, watery, and tasteless. Heavy freshets, such as occur in the rivers discharging into Chesapeake Bay and at various places on the Gulf coast, frequently so lower the density of the water as to practically exterminate the oysters on certain beds. Experience apparently indicates that the best oysters are grown in densities between about 1.011 and 1.022, the former being approximately the specific gravity over the Tangier Sound beds, the latter that over the deep-water oyster-grounds of Long Island Sound.

* The figures represent the specific gravity as measured with the salinometer, that of pure water being 1.000.

Change of density has an important effect upon the spawning of oysters. At St. Jerome Creek, Dr. Ryder found that the eggs could not be impregnated in a density much exceeding that in which the parent animals live. With oysters raised in water ranging from 1.007 to 1.0095 it was found that the milt was killed by a density greater than 1.013, the individual spermatozoa losing their mobility in a few moments when exposed to the greater density. The frequent failure of oysters to spawn in the season in which they are transplanted is perhaps in a measure owing to this cause. In Chesapeake Bay they are usually transplanted from deeper, denser water to more shallow and less dense, and when taken from the Chesapeake to Long Island Sound they go through a similar experience. There is at the same time, however, usually a change in temperature, and doubtless both factors combine to produce the effect noticed.

It has been suggested by Lieutenant Platt that the density of the water has an effect on the distribution of the set; that is, the specific gravity of the swimming embryo is such that it can not sink in dense water and therefore must become attached in marginal beds between tide marks, as is seen on the "raccoon" oyster-beds of South Carolina.

In some places it has been found that the best results in oyster-culture are to be had in brackish water, and Dr. Ryder suggests that this may be largely due to the fact that water of the lower densities is usually shallower, and consequently warmer and better adapted to the production of an abundant supply of the minute organisms which constitute the principal source of the oyster's food. There can be no doubt, however, that the eastern oyster is distinctively a brackish-water form. It has been found that it will not thrive in French waters perfectly adapted to the culture of the European species, and there is reason to believe that it will reproduce itself in a lower density than is necessary for the native oyster of California.

For determining the temperature and the density of sea waters the apparatus shown in plate II is used. It consists of a glass float with a long stem and a large bulb, weighted so as to sink in fresh water to a point near the top of the stem. The stem is graduated to read between 1.000 and 1.031, the figures representing the specific gravity; that is, they show the weight of the salt water, an equal body of fresh water being supposed to weigh 1.000.

In practice a scale having the entire range would be too long for safety and convenience, and therefore the salinometers are made in sets of three, reading from 1.000 to 1.011, from 1.010 to 1.021, and from 1.020 to 1.031, respectively.

There is also provided with them a deep copper cup or cylinder, at one side of which a thermometer is attached (plate II). The method of using the salinometer is as follows: The cup is filled with the water to be tested, the appropriate float is placed in the water, the density of

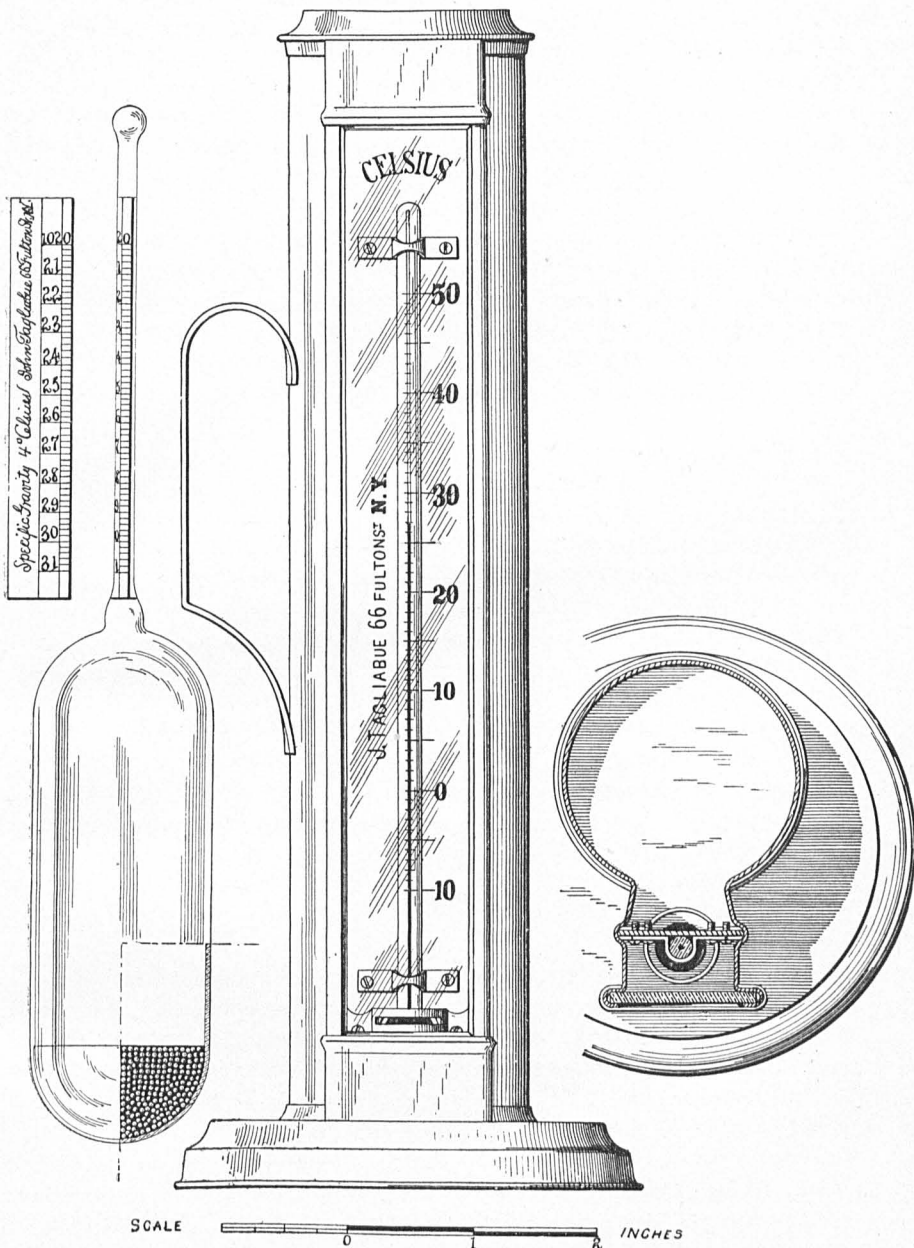

SALINOMETER AND SALINOMETER CUP.

The scale opposite the stem of the salinometer represents that of the high reading spindle as if unrolled. It registers densities between 1.020 and 1.031.

which will be the reading of the scale nearest the point where the surface of the water touches the stem. For purposes of oyster-culture the finer graduations may be neglected. To show the specific gravity, the number "1.0" should always be placed in front of the scale reading; for example, if the surface of the water should stand opposite the scale reading "15," the density would be 1.015. The test should be made immediately after the water specimen has been collected and a reading of the thermometer should be taken at the same time.

For practical purposes on the oyster-beds, a bottle or jar not less than 10 inches deep may be used instead of the copper cup, and any ordinary thermometer may be used for obtaining the temperature. The cheap, wooden-cased instruments known as "bath thermometers" serve very well, as they have no metal parts to be corroded by the salt water. In most oyster regions the salinometer reading from 1.020 to 1.031 will not be necessary, as the density on the oyster-beds rarely falls within its range.

The specimens of water should be from the bottom, or near it, and may be conveniently obtained by the following rough method: An empty jug or large bottle weighted and corked is lowered to the bottom by means of a line. The cork is then pulled out by jerking on a cord previously attached to it, the receptacle fills with a sample of water from or near the bottom, and if hauled rapidly to the surface it answers the practical purposes of more scientific and accurate apparatus.

SILT, MUD, AND SUSPENDED MATTER.

A bottom composed of soft mud, into which the young oysters would sink and become stifled, is unfavorable to oyster-culture or to the development of natural beds. If, however, hard objects are distributed over the bottom they will become collectors of spat so long as the surface remains clean and free from slime and sediment, and the importance of having water containing as little sedimentary matter as possible is manifest if it is desired to produce permanent beds or catch the floating fry.

Oysters will grow more rapidly on muddy bottoms, or in their vicinity, than they will elsewhere, as such situations are usually more productive of food materials. This food is in the form of suspended or swimming organic particles, and, therefore, filtered water, or that which is devoid of suspended matter of all kinds, lacks one of the essential requirements of successful oyster-culture. The most desirable water is that which contains an abundance of minute living particles with a minimum of suspended inorganic matter. An organic slime, however, such as rapidly forms on exposed surfaces in some localities, is as effectual in preventing fixation as is inorganic sediment. In many places in Chesapeake Bay and in the bays on the New Jersey coast the sediment, as well as the bottom mud, is largely composed of the finely comminuted fragments of vegetable matter, seaweeds, etc., the rapid deposit of which soon covers with a soft film the surface of all objects

exposed to it, except when the currents are sufficient to exert a scouring influence.

Large oysters are not so susceptible as small ones to the effects of mud, but even those full grown may be stifled or buried by the rapid deposit of mud or sediment, whether this be of organic or inorganic origin. Freshets and heavy seas often cause great damage by the amount of mud, sand, and other debris which they carry upon the beds.

The question of the physical characters of a suitable bottom for oyster-culture is considered in another connection.

TIDES AND CURRENTS.

Tides and currents are important factors in the growth and culture of the oyster. They bring about the aeration of the water and oxidation of its dead organic ingredients; they have a scouring action upon the bottom and thereby cleanse the cultch, and at the same time serve as the vehicles for the transportation of food, of the genital products, and of the young. Stagnant water tends to become exhausted of its oxygen; it is heated by the sun, and the contained organic matter undergoing death and decomposition causes it to become foul and fatal to the oysters in the vicinity. With currents, however, a fresh supply of oxygen is constantly being supplied for respiration and for the combustion of the effete matter, which is thus rendered harmless.

Over densely-populated beds the food supply, unless unusually prolific, as in *claires*, would in time become exhausted. The oyster can not, of course, change its location, but the same purpose is subserved by currents constantly bringing a fresh supply of food-laden water within the influence of the ciliary action by which the oyster captures its food.

The genital products of the oyster, both male and female, are simply discharged into the surrounding water. The eggs are absolutely immobile, and while the spermatozoa, or male elements, possess the power of locomotion to some extent, they are obviously incapable of moving very far during the limited period of their mobility. In densely-crowded beds no doubt a considerable proportion of the eggs may become fertilized even without the agency of currents, but where, as upon most oyster-grounds, the oysters are scattered, the proportion must be exceedingly small. Oystermen are well acquainted with the fact that upon beds removed from the influence of the tides the rate of reproduction is very low.

Currents, however, will bring about a distribution of the genital products, more particularly the almost impalpable milt, and thus give an opportunity for obtaining better results by increasing the chances for spawn and milt to come into contact. Although the young spat is a free-swimming organism, yet its powers are not sufficient to carry it to any great distance from its original source. It is transported mainly by tidal currents, and, as a general rule, the more widely distributed a given lot of spat, the greater is the number liable to become success-

fully set. Currents, even of considerable strength, do not prevent the settling down of the larval oyster and its fixation upon a proper surface.

In the preparation of this surface the currents are also effective, inasmuch as by their scouring action they prevent the deposit of sediment and slime, which soon render collectors unsuitable for the fixation of the young oyster. Finally, where the fry are uniformly distributed in a body of water a collector placed in a current will collect more spat than one in quiet water, because a greater quantity of water and consequently a larger number of fry will be brought into contact with it. Points around which fry-charged water sweeps with sufficient velocity to prevent the deposit of sediment are good places for the location of collectors.

Freshets, for several reasons, usually have a bad effect upon the oyster-beds. When the volume of fresh water is large, the oysters suffer from the decrease in the density. Large quantities of mud and sediment are brought down by the floods and often deposited on the beds, covering up the cultch and smothering the young spat, and, if the amount of sedimentation is very great, even injuring or killing the adults.

DEPTH OF WATER.

The vertical range of the cultivated oyster beds is from the shore line to a depth of 15 fathoms. In New Jersey, Chesapeake Bay, South Carolina, and other places, there are beds which are partially exposed at low water, while in Long Island Sound successful oyster-culture is carried on in depths as great as 15 fathoms, the average over planted grounds in that region, however, being from 5 to 6 fathoms. In most places, however, the planting is done in shallow bays and coves.

WEATHER CONDITIONS—STORMS, GALES, AND ICE.

Gales rarely have any influence upon adult oysters in deep water, but they sometimes seriously affect shallow-water beds. Heavy surf occasionally carries away the oysters and throws them upon the beach, or they may be buried *in situ* by the sand and seaweeds which the waves lodge upon the beds. Sometimes, after the lapse of a short time, the beds are again uncovered by the eroding effects of currents, but in many cases they are practically destroyed, both old and young being smothered by the overlying deposits.

In winter, ice often grounds upon the beds during gales and does considerable damage. The oyster appears also to be temporarily affected by the mere freezing of the waters, and it is said that, in the Chesapeake, oysters on the deeper beds are more affected than those in shoal and brackish water, becoming dark, slimy, and worthless for the market. Ten days or a fortnight must elapse after the disappearance of the ice before they become again fit for use.

The fry are more affected by the weather than are the adults. Dr. Ryder found that in the swimming stage they were killed by thunder-

storms, by cold rains, and by sudden falls in temperature, and the prevalence of such weather during the spawning season must have an important effect upon the set of spat.

FOOD.

The oyster feeds upon both animal and vegetable food, the particles of which are of microscopic dimensions. The fry and young spat consume relatively large quantities of bacteria and monads, among the most minute organisms known to microscopists. According to Dr. Ryder:

Many of the food balls found in the intestine of the recently attached spat will measure under $\frac{1}{10000}$ inch in diameter. The cavity of the little creature's stomach measures only $\frac{1}{20000}$ inch. Yet in this minute digestive cavity the food is actually found rotating in the form of minute rounded and oval bodies, which are kept in motion by the action of the cilia which line the stomach. That these bodies must have been of about the size noted when they were originally swallowed and as seen rotating in the stomach is evident from the fact that the young oysters, like the adults, are wholly without teeth or triturating organs of any kind.

This minute kind of vegetable and animal food is found more or less abundantly in all sea water, and is especially abundant during the spawning season, when the decomposition and disintegration of all kinds of minute organic debris floating about in the water is in rapid progress, owing to the prevalent high temperature of the air and water. It is, therefore, probable that very few otherwise suitable locations exist where it is not possible to find an abundance of the proper sort of food for the oyster during its very earliest stages of growth.

The food of the slightly more advanced spat and the adults is found to consist of diatoms, rhizopods, infusoria of all kinds, monads, spores of algae, pollen grains blown from trees and plants on shore, their own larvæ or fry, as well as that of many other mollusks, of bryozoa and minute embryos of polyps and worms, together with other fragments of animal or vegetable origin, and sometimes even minute crustaceans. In variety of food the oyster, therefore, has a wide range of choice. There are also few locations otherwise well adapted which will not supply an abundance of food for the animal, which, it is to be remembered, captures and hoards millions of these minute plants and creatures in its stomach, where they are digested and incorporated into its own organization. It therefore follows that when we eat an oyster we are consuming what it required millions of the minutest organisms in the world to nourish. The oyster is consequently a sort of living storehouse for the incorporation and appropriation of the minute life of the sea, which could never be rendered tributary to the food supply of mankind in any other way except through the action, growth, and organization of this mollusk.*

The quantity of young oysters consumed by the adults is doubtless enormous, 200 fry having been found in the stomach of single individuals. Not only the free-swimming fry, but eggs and spermatozoa are fed upon, and an insight is here gained into the ultimate fate of some of the vast numbers of genital elements which the parents shed into the water.

While the oyster feeds upon both plant and animal organisms, it must be remembered that it is primarily dependent upon the former. That not only is the major portion of the food of the oyster itself of vegetable origin, but the minute animal forms are dependent for their sustenance upon the plants and are not to be found in abundance far removed from them.

* Rept. U. S. F. C. 1885, pp. 387-388.

In most regions which have been investigated the plants constitute by far the most important item of diet, usually over 90 per cent of the food contents of the stomachs being composed of vegetable matter. Of this diatoms are the chief constituents, and to a certain extent the food value of any given oyster region may be measured by the quantity of these minute plants which it is capable of producing.

Diatoms are numerous both in species and individuals, and all possess two interesting peculiarities: They are incased in a siliceous or flinty box and they possess the power of locomotion, the first permitting their ready identification in the stomach contents and the second aiding in their distribution. More or less regular diurnal migrations of swarms to and from the surface of the water take place with the variations in the light. During sunlight they rise from the bottom, and are then readily transported by the currents, again settling down as darkness comes on. They feed and grow in size most actively during the day, but multiply in number principally at night. Diatoms are important, not only in fattening the oyster, but they also have a profound influence upon its flavor and color.

The oyster is said to feed mainly during flood tide, opening its shell at that time to admit the influx of water with its contained organisms. Investigation by Dr. Bashford Dean showed that the stomachs were practically foodless in the morning, contained most food at midday, and a somewhat reduced quantity at evening, thus suggesting that feeding was most active during intense daylight.

Dr. Dean remarks:

This suggestion, as to the feeding habits of the oyster, is not a surprising one when we remember that it is during the strongest sunlight than diatoms, as plants keenly sensitive to the sun, are most active and are known to migrate in floating clouds from the bottom of the surface.

As is mentioned in the section relating to the anatomy of the oyster, the water drawn into the mantle cavity by the action of the cilia is filtered through the rectangular openings in the gills into a chamber or tube lying above each gill, whence it passes backward and out of the shell in a current dorsal to the entering stream. The particles of food in the inflowing stream become entrapped in a sticky mucus covering the gills, and, together with this mucus, in part, are carried in a steady stream toward the mouth, the motion being imparted to the mass by the rhythmic action of the cilia. The palps and mouth are also ciliated, which insures the continuance of this current into the stomach, where the food particles undergo digestion. A very considerable proportion of inert matter, sand, mud, etc., of no nutrient value passes into the alimentary tract along with the food, the oyster having no means of making selection.

The temperature, depth, and density of the water have considerable effect upon the food supply. In clear, warm weather the amount of food matter is increased by the natural multiplication of the minute

organic bodies which find such conditions favorable, but at the same time many of these organisms, particularly the diatoms and zoospores, are attracted to the surface by the sunlight and are thus placed beyond reach of the oyster. In rainy or stormy weather, however, they are driven down toward the bottom, where they may be brought within the influence of the cilia, and at the same time there is an increase in the amount of other organic sediment, much of which is available as food.

Shallow water, as a rule, produces more food than the greater depths, owing largely to the fact that it warms more quickly and thus increases the vitality of both the oyster and its food. The latter shows its greater vigor by a more rapid multiplication, and the former by its greater consumption of the food which is thus provided for it. In other words, the chemical and physiological changes resulting in the conversion of inorganic matter into oyster tissue through the medium of plant life go on more rapidly in the presence of warmth. It must also be remembered that the shallow waters are generally of a lower density than the deeper ones, and this approach to brackishness appears to be also favorable to the production of food.

Summer and fall, the seasons of most vigorous growth of aquatic vegetation, are in most localities likewise the best seasons for the growth of the oyster, while in winter the food supply is at a minimum, the vital activities of the oyster are much reduced, the ciliary action is weak, and the oyster in a state of semihibernation, both the waste and repair of tissue being reduced to a minimum.

That the oyster in many places reaches its greatest fatness and perfection late in fall is due partly to the quantity of food produced during the summer and partly to the cessation of the drain which the act of spawning entails. Shortly before and during the spawning season most of the nutrient matter in the food is utilized in the rapid growth of the sexual products, but after the cessation of spawning it is converted into surplus protoplasmic matter, which is stored up in the tissues and thereby renders the oyster fat and well flavored.

ENEMIES.

At all stages of its career the oyster is preyed upon by more or less dangerous foes. It might be supposed that an animal inclosed in a ponderous armor, which in times of danger is a complete encasement, would be free from the attacks of enemies, but no organism has ever evolved a protective device which some other organism has not found partially vulnerable; and it must be remembered that the oyster is not always as well protected as we find it in the adult and marketable condition. In the young state, before attachment, the minute and delicate fry is fed upon extensively by the adult oyster and by other mollusca, lingulas, worms, sponges, and hydroids. Upward of 200 young have been found in the stomach of an oyster, and there is but little doubt large numbers are so consumed on every oyster-bed. Probably the

menhaden, the alewife, and other fish equipped with delicate sifting devices at times find the oyster fry of some importance in their dietary.

After the attachment of the spat other enemies, active and passive, wage war upon it. The passive enemies affect its welfare by consuming its food or by smothering it beneath their own more active growth. Of the former class, mussels, lingulas, etc., are examples, but as the food upon an oyster-bed is usually sufficient for all, this is not a very important consideration, particularly as in the end an equilibrium is established through the intimate reciprocity which exists between the various forms of life.

The conditions of life upon an oyster-bed are favorable to the rapid growth of dense sponges, mussels, barnacles, hydroids, and tube-building worms, which establish themselves upon the young growth, often increase more rapidly than their hosts, and, in many cases, overgrow them to such an extent as to cut off the supply of food and oxygen. (Plate XVII). Aquatic vegetation sometimes has the same effect when its growth becomes extensive. Certain worms, such as *Serpula*, and especially *Sabellaria* (plate xv, fig. 3), often build their tubes of lime or sand so rapidly as to produce dense accumulations upon the surface of the shells, thus forming a nidus for the collection of sand and mud. Considerable loss has at times resulted from the suffocation of oysters by sponges, worm tubes, and vegetable growths, but most of these passive forms have a compensatory use in the food which their spores, eggs, and young furnish to the oysters.

The active enemies of the adult oyster are those which injure it by direct attacks, such enemies being found in most of the classes of zoological life having aquatic representatives.

Fishes of several kinds are found habitually on the oyster-beds. Most of these offer no direct injury and they may even benefit the oyster by keeping down the crowding masses of hydroids and vegetable life, but a few species, of which the drumfish is apparently the most destructive upon the Atlantic coast, consume considerable quantities of oysters as food. At times much damage has thus been wrought to the beds in the vicinity of New York and along the New Jersey coast. In San Francisco Bay the stingray is the most feared enemy of the oyster, and schools of them frequently "clean out" the beds to which they gain access, their teeth being such that the shells are crushed into fragments in their grasp. Some of the skates and rays on the eastern coast no doubt have similar habits, but they do not appear in sufficient numbers to cause much harm.

The drills are the most destructive enemies of the oysters in the Chesapeake and adjoining regions, as well as upon most of the more important inshore beds northward. There are, perhaps, several species, but the most destructive is the form known to naturalists as *Urosalpinx cinerea* (plate xv, fig. 1). It is a snail-like mollusk, which, by means of its rasping tongue, drills a tiny hole in the shell of the oyster, through which it extracts the soft parts. It is only the younger oysters which are thus

attacked, as after they become about 2 inches long the shell is stout enough to resist this foe. The loss sustained from this source is very great, as the drills are often present in large numbers and continue their work throughout the year.

The two large conch-like gasteropods of the Atlantic coast, *Sycotypus canaliculatus* and *Fulgur carica* (plate xv, fig. 4), also feed upon the oyster, from their size being capable of attacking the largest individuals. These periwinkles, "winkles," or conchs, as they are variously called, appear to do comparatively little damage, as they are not present in sufficiently large numbers anywhere except perhaps on the coast of Florida.

Other gasteropods doubtless feed upon the oyster, but not to an extent worthy of consideration.

Upon brackish-water beds the starfish (plate xvi) is not usually troublesome, and in Chesapeake Bay it is practically unknown, but in Long Island Sound, and especially upon the offshore beds in the more saline waters, it is the most destructive enemy with which oystermen have to contend. It is there extremely abundant at times, but it is a migratory form, and sometimes certain beds are unmolested while others nearby are almost ruined by its inroads. The appearance of this pest upon the beds is without warning, and frequently the ground is almost devastated before the owner is aware of their presence. Vast swarms or schools sweep across the beds, devouring the oysters in their path. The migration is said to take place in the form of a "winrow," moving in some cases at the rate of about 500 feet per day. Apparently the only way to stop the march of these hordes is to catch them up by some of the methods indicated in pp. 313-316. By energetic work the damage may often be confined to the beds at the edge of a cultivated area.

The starfish begins its destructive work soon after it abandons its free-swimming larval condition, at a time when it is hardly larger than a pin's head, and continues it through life. At first it feeds upon the tiny spat, but as it grows it increases the size of its prey, though even the full-grown stars rarely feed upon oysters over two, or, at most, three years old. Small oysters are often taken bodily into the stomach of the starfish, a proceeding which is of course impossible with large ones or those firmly attached to large cultch. It is not definitely known how the oysters are opened, but Dr. Paulus Schiemenz has pretty conclusively demonstrated the probability that they are actually pulled open by muscular effort on the part of the starfish.

If the common starfish be examined there will be found on the under surface of each arm four rows of closely crowded suckers or feet extending from the mouth to the tips of the arms. These feet are tubular and are extended by having a fluid pumped into their cavities by a special apparatus in the body of the starfish. The suckers at the ends may be caused to adhere to foreign bodies with great tenacity, and if the hydrostatic pressure be then relieved and the muscles of the stalks of the feet contract, a strong pull may be exerted by each foot, either

independently of its fellows or in conjunction with them. As shown in plate XVI, the starfish feeding upon oysters or other lamellibranchs arches itself over the ribs or lips of the mollusk so that some of its arms are on one side and some on the other. In this position a large number of the sucker feet are attached to each valve, and when they contract a stress is produced in opposite directions and opposed to the force of the adductor muscle which tends to keep the valves of the oyster closed. Dr. Schiemenz has shown by actual measurement that in this manner there is exerted a force sufficient to overcome any resistance which the oyster may offer. It is eventually tired out by the persistence of its enemy, its shell is forced open, the stomach of the starfish is inserted, and within a few hours the valves only remain.

Another annoying and frequently very destructive enemy of the oyster is the boring-sponge, *Cliona sulphurea*. It differs from the enemies before enumerated in that it consumes the shell and not the soft parts of the unfortunate oyster. The young sponge lives in galleries excavated in the substance of either dead or living shells which are soon reduced to a honey-combed condition, when they may be crumbled to powder between the fingers. When they attack a living oyster, as the galleries penetrate the inner face of the shell, an irritation of the mantle is produced, causing an increased amount of shell deposit at that point. If the inside of such a shell be examined it will be found to be covered with blister-like shell deposits, sealing up the openings to the galleries, and many curious distortions follow from the destruction of the hinge area and the portion of the shell to which the adductor muscle is attached. Although the oyster itself is not attacked, yet it becomes poor, thin, and watery and often dies from the exhaustion induced by the constant effort to keep its shell intact.

The older specimens of the boring-sponge are large, dense, yellow masses, often 6 or 7 inches in diameter and usually inclosing the shells, etc., to which they were originally attached. All stages intermediate between those described can usually be found upon infested oyster-beds. The older, more massive forms often suffocate the oyster through the denseness of their growth.

In addition to the various forms already enumerated there is a large population upon the oyster-beds which is not injurious. This, of course, includes many of the minute food forms, together with some of the fishes and crabs. The latter, at least on the Atlantic coast, can not be regarded as very destructive, but on the contrary they serve as scavengers, removing dead matter from the beds when it might otherwise become foul and fatal to the oysters. It will be seen that the population of the oyster-beds is large and extremely complex. The social relations of the various forms are exceedingly intricate and have, in the course of evolution, become nicely adjusted in a system of reciprocity. The law of the oyster beds is "give and take," each of a large number of organisms giving something for the general welfare and taking what it needs for its own well being.

DESCRIPTION OF NATURAL BED.

Dr. Brooks thus describes a natural oyster bank:

An examination of a Coast Survey chart of any part of the Chesapeake Bay or of any of its tributaries will show that there is usually a midchannel or line of deep water where the bottom is generally soft and where no oysters are met with, and on each side of this an area where the bottom is hard, running from the edge of the channel to the shore. This hard strip is the oyster area. It varies in width from a few yards to several miles, and the depth of water varies upon it from a few feet to 5 or 6 fathoms or even more. But there is usually a sudden fall at the edge of the channel where the oysters stop, and we pass onto hard bottom; and a cross-section of the channel would show a hard, flat plane with oysters on each side of the deep, muddy channel. The oyster bottom is pretty continuous, except opposite the mouth of a tributary, where it is cut across by a deep, muddy channel. The solid oyster rocks are usually situated along the outer edge of this plateau, although in many cases they are found over its whole width nearly up to low-tide mark or beyond. As we pass south along the bays and sounds of Virginia and North Carolina, we find that the hard borders of the channel come nearer and nearer to the surface until in the lower part of North Carolina there is on each side of the channel a wide strip of hard bottom, which is bare at low tide and covered with oysters up to high-water mark, although the oysters are most abundant and largest at the edge of the deep water, where they form a well-defined reef. In our own waters there is usually a strip along the shore where no oysters are found, as the depth of water is not great enough to protect them in winter. The whole of the hard belt is not uniformly covered with oysters, but it is divided up into separate oyster rocks, between which comparatively few can be found.

The boundaries of a natural rock which has not been changed by dredging are usually well defined, and few oysters are to be found beyond its limits. The oysters are crowded together so closely that they can not lie flat, but grow vertically upward, side by side. They are long and narrow, are fastened together in clusters, and are known as "coon oysters."

When such a bed is carefully examined it will be found that most of the rock is made up of empty shells, and a little examination will show that the crowding is so great that the growth of one oyster prevents adjacent ones from opening their shells, and thus crowds them out and exterminates them. Examination shows, too, that nearly every one of the living oysters is fastened to the open or free end of a dead shell which has thus been crowded to death, and it is not at all unusual to find a pile of five or six shells thus united, showing that number two has fastened, when small, to the open end of number one, thus raising itself a little above the crowd. After number one was killed, number two continued to grow, and number three fastened itself to its shell, and so on. Usually the oysters upon such a bed are small, but in some places shells 12 or 14 inches long are met with. The most significant characteristic of a bed of this kind is the sharpness of its boundaries. In regions where the oysters are never disturbed by man it is not unusual to find a hard bottom extending along the edge of the shore for miles and divided up into a number of oyster rocks, where the oysters are so thick that most of them are crowded out and die long before they are full grown, and between these beds are areas where not a single oyster can be found. The intervening area is perfectly adapted for the oyster, and when a few bushels of shells are scattered upon it they are soon covered with young, and in a year or two a new oyster rock is established upon them, but when they are left to themselves the rocks remain sharply defined.

What is the reason for this sharp limitation of a natural bed? Those who know the oyster only in its adult condition may believe that it is due to the absence of powers of locomotion and may hold that the young oysters grew up among the old ones, just as young oak trees grow up where the acorns fall from the branches. This can not be the true explanation, for the young oysters are swimming animals, and

they are discharged into the water in countless numbers, to be swept away to great distances by the currents. As they are too small to be seen at this time without a microscope it is impossible to trace their wanderings directly, but it is possible to show indirectly that they are carried to great distances and that the water for miles around the natural bed is full of them. They serve as food for other marine animals, and when the contents of the stomachs of these animals are carefully examined with a microscope the shells of the little oysters are often found in abundance. While examining the contents of the stomach of *lingula* in this way I have found hundreds of the shells of the young oysters in the swimming stage of growth, although the specimens of *lingula* were captured several miles from the nearest oyster-bed. As *lingula* is a fixed animal the oysters must have been brought to the spot where the specimens were found, and as the *lingula* has no means of capturing its food, and subsists upon what is swept within its reach by the water, the presence of so many inside its stomach shows that the water must have contained great numbers of them.

It is clear, then, that the sharp limitation of the area of a natural oyster bed is not due to the absence in the young of the power to reach distant points. There is another proof of this, which is familiar to all oystermen—the possibility of establishing new beds without transplanting any oysters. The following illustration of this was observed by one of your commissioners: On part of a large mud flat which was bare at low tide there were no oysters, although there was a natural bed upon the same flats, about half a mile away. A wharf was built from high-tide mark across the flat out to the edge of the channel, and the shells of all the oysters which were consumed in the house were thrown onto the mud alongside the wharf. In the third summer the flat in the vicinity of the wharf had become converted into an oyster-bed, with a few medium-sized oysters and very great numbers of young, and the bottom, which had been rather soft, had become quite hard; in fact, the spot presented all the characteristics of a natural bed. Changes of this sort are a matter of familiar experience, and it is plain that something else besides the absence in the oyster of locomotive power determines the size and position of a bed.

Now, what is this *something else*? If the planting of dead shells will build up a new bed, may we not conclude that a natural bed tends to retain its position and size because the shells are there? This conclusion may not seem to be very important, but I hope to show that it is really of fundamental importance and is essential to a correct conception of the oyster problem.

Why should the presence of shells, which are dead and have no power to multiply, have anything to do with the perpetuation of a bed?

We have already called attention to the fact that oysters are found on the hard bottom on each side of the channel, while they are not found in the soft mud of the channel itself, and it may at first seem as if there were some direct connection between a hard bottom and the presence of oysters, but the fact that no oysters are found upon the hard, firm sand of the ocean beach shows that this is not the case. As a matter of fact, they thrive best upon a soft bottom. They feed upon the floating organic matter which is brought to them by the water, and this food is most abundant where the water flows in a strong current over soft organic mud. When the bottom is hard there is little food, and this little is not favorably placed for diffusion by the water, while the water which flows over soft mud is rich in food.

The young oysters which settle upon or near a soft bottom are therefore most favorably placed for procuring food, but the young oyster is very small—so small that a layer of mud as deep as the thickness of a sheet of paper would smother and destroy it. Hence the young oysters have the habit of fastening themselves to solid bodies, such as shells, rocks, or piles, or floating bushes, and they are enabled to profit by the soft bottoms without danger.

Owing to the peculiar shape of an oyster shell, some portions usually project above the mud long after most of it is buried, and its rough surface furnishes an excellent basis for attachment. It forms one of the very best supports for the young, and a little swimming oyster is especially fortunate if it finds a clean shell to adhere to when it is ready to settle down for life. Then, too, the decaying and crumbling

shells are gradually dissolved in the sea water, and thus furnish the lime which the growing oyster needs to build up its own shell. As long as the shell is soft and thin the danger from enemies is very great, and this danger is greatly diminished as soon as the shell becomes thick enough to resist attack. It is, therefore, very necessary that the shell should be built up as rapidly as possible, and an abundant supply of food in general will be of no advantage unless the supply of lime is great enough for the growth of the shell to keep pace with the growth of the body. All sea water contains lime in solution, but the percentage is, of course, greatest near the sources of supply. It is well known that on coral reefs, which are entirely made of lime, all kinds of shelled mollusks flourish in unusual abundance and have very strong and massive shells, and our common land and fresh-water snails are much larger and more abundant in a limestone region than in one where the supply of lime is scanty. In such regions it is not unusual to find the snails gathered around old decaying bones, to which they have been drawn in order to obtain a supply of lime for their shells.

From all these causes combined it results that a young oyster which settles upon a natural oyster-bed has a much better chance of survival than one which settles anywhere else, and a natural bed thus tends to perpetuate itself and to persist as a definite, well-defined area; but there is still another reason. As the flood tide rushes up the channels it stirs up the fine mud which has been deposited in the deep water. The mud is swept up onto the shallows along the shore, and if these are level much of the sediment settles there. If, however, the flat is covered by groups of oysters, the ebbing tide does not flow off in an even sheet, but is broken up into thousands of small channels, through which the sediment flows down to be swept out to sea.

The oyster-bed thus tends to keep itself clean, and for these various reasons it follows that the more firmly established an oyster bed is the better is its chance of perpetuation, since the young spat finds more favorable conditions where there are oysters, or at least shells, already than it finds anywhere else.

Now, what is the practical importance of this description of a natural bed? It is this: Since a natural bed tends to remain permanent, because of the presence of oyster shells, the shelling of bottoms where there are no oysters furnishes us with a means of establishing new beds or of increasing the area of the old ones.

The oyster-dredgers state, with perfect truth, that by breaking up the crowded clusters of oysters and by scattering the shells the use of the dredge tends to enlarge the oyster-beds. The sketch which we have just given shows the truth of this claim, but this is a very rough and crude way of accomplishing this end.*

This description, so far as it relates to the oysters themselves, gives a good idea of the average oyster-bed, though they differ somewhat in details in different localities. But, as shown in the sections which treat of the enemies and the food of the oyster, the latter is very far from constituting the entire population of the beds. The same causes which induce the growth of the oyster, the firm basis of attachment, the surrounding food-producing mud, the favorable density and temperature, all tend to make the oyster-bed a center teeming with aquatic life. Thus a single point of attachment, a firm nucleus projecting naturally above the surrounding mud, or a few shells thrown upon the muddy bottom may give rise to a community where life is as abundant and the struggle for existence as complex and strenuous as is anywhere found in nature.

* Brooks, W. K., Maryland Oyster Report, 1884, pp. 86 to 88, inclusive.

DESTRUCTION OF NATURAL BEDS—CAUSES AND REMEDIES.

Until a comparatively recent date our supply of oysters was drawn almost entirely from the natural beds, which were originally so vast that it was a common saying that they were inexhaustible. The fallacy of this view has been abundantly proven, and wherever reliance has been placed upon natural beds solely there has been a decreasing supply to meet an increasing demand. Many causes have been cited to account for the decrease in the productiveness of the oyster-beds, but wherever unprejudiced investigation has been brought to bear upon the subject the verdict has always been that the fishing upon the beds has outgrown their fecundity.

Vast as is the production of spawn, the chances against its growth to maturity are such as to limit the productiveness of the beds. Much of it fails of fertilization. Most which passes that critical stage becomes a prey to enemies or falls upon unsuitable bottom, where it fails of attachment and sinks in the ooze. Even after the vicissitudes of larval life are passed the infantile spat may be buried in an accumulation of organic or inorganic sediment, or it may be devoured by enemies against which it can present no adequate defense. Storms may tear the adult oysters from their attachment and cast them upon the shore, or they may become covered by sand and seaweeds drifted in by the waves; or, again, excessively cold weather may cause their death in exposed places by freezing.

Numerous as are the perils which beset them under their natural surroundings, they have, upon the whole, found the conditions favorable for their maintenance and increase until civilized man began his systematic attacks. It is true that before the appearance of the white man upon the scene they had disappeared from regions where they were formerly found, but upon our coasts such cases are isolated and rare.

Without here going into the evidence, it may be asserted as a demonstrated fact that overfishing is the cause of the depletion of our oyster-beds, and that it produces its damaging effect in several ways:

1. It removes the adult oysters, which are either spawning or are capable of spawning, and thereby reduces the reproductive power of the bed as a whole.

2. It removes the shells, and therefore decreases the available points of attachment of the spawn. When the oysters are not culled on the beds this effect is aggravated by the removal of the dead shells.

3. Spat and young oysters attached to the shells of the adults are removed from the beds, and as it is impracticable in many cases to detach them they are of necessity destroyed.

4. The quantity of oysters taken and destroyed from the several causes mentioned is greater than that which is permitted to annually grow up to take their places.

Many causes have been assigned as tending to deplete the oyster-beds, and many remedies have been proposed. Various phases of the

oyster business have been cited to show cause why they should not be curtailed or abolished as destructive. It has been proposed to restrict the demand by prohibiting canning; to prohibit the use of this or that kind of apparatus, or to interfere in various ways, with more or less legitimate methods of meeting and increasing the demand.

The attempts that have been made to keep the demand upon the beds within the limit of their fecundity have so far been failures, and such attempts are also seen to be illogical when it can be shown that the reciprocal measure, increasing the supply, is perfectly feasible.

The dictates of sound economics require that no effort be made to restrict the demand until it can be shown that efforts to increase the supply are futile. A growing demand for a product is the most trustworthy indication of an industry's prosperity, and the only rational manner in which to bring the supply and demand into equilibrium is to increase the former. Only after the failure of all efforts to save the supply from total extinction, should a restriction be placed upon the demand.

The close season has been a favorite measure in protective legislation, as it has been in most legislation looking to the perpetuation of game and fish. It is usual to fix the close season during the spawning months, upon the theory that the reproductive act should be allowed to proceed unmolested. It really matters but little whether the oyster is taken during the season of spawning or a month or two before; the effect upon the fishery is the same, as in either case the bed is deprived of an individual capable of reproducing its kind. The only effect of a close season, whenever occurring, is to reduce the time during which the oyster is subject to attack from the oystermen. Even this is of little avail with the sedentary oyster, for it is possible for 365 men, fishing ten days, to as effectually "clean up" a bed as can be done by 10 men fishing throughout the year. This has been found to be the practical result of a close season in some places; the first few days of fishing removing so many oysters as to make it unprofitable to work the beds during the rest of the year.

The methods by which the increased demand resulting from a widening of the markets may be met will be treated of in another connection. It may become necessary in some parts of this country, as in Europe, to reserve the natural beds for the production of seed. Such a reservation would naturally excite the strenuous opposition of the oystermen; but should the industry ever be reduced to the desperate condition at one time found in France, correspondingly desperate remedies must be invoked.

INCREASE OF SUPPLY BY ARTIFICIAL MEANS.

In many countries in which oysters are an important item of food it has been found necessary to give nature some assistance in order to maintain or increase the supply of oysters available for the markets. The direction in which this assistance is rendered is governed by local conditions, but in general it may be stated that all methods of oyster-culture depend for their success upon the modification of the natural

conditions in such a manner as to bring about one or several of the following results:

1. An increase in the number of eggs successfully fertilized.
2. An increase in the surfaces available for fixation, and consequently an increase in the number of spat which become fixed and pass through the early stages of spat existence.
3. The utilization and salvage of spat, which would otherwise fall victims to the several vicissitudes of their careers—storms, frosts, crowding, etc.
4. A decrease in the liability to attacks from enemies.
5. The utilization of otherwise neglected bottoms and food supplies.

Upon our coasts the objects set forth above, or some of them, have been best realized by the process of "planting." This consists in placing firm bodies in the water for the purpose of catching the spat or in spreading young oysters upon the bottom in places suitable for their growth. Vast as are our oyster-fields, but a small portion of the bottom available for the growth of this mollusk has been utilized by nature. This has arisen from the fact that in many cases where the other conditions are favorable the bottom is of such a character as to prevent the attachment of the young, though perfectly adapted to the rapid growth of the adults. If then the spat be caught on planted culch, or partially grown oysters be placed upon such bottoms, the difficulty is overcome and nature has been assisted to the degree necessary and all or some of the conditions mentioned above are more or less completely fulfilled; the first by increasing the number of adult oysters in any region, and by their closer aggregation; the second, by the process of preparing the ground and sowing the shells; the third, by the use of seed from regions less favorable to its maturing; the fourth, from the greater care with which a bed under private ownership will be watched and guarded, and the fifth by the very act of planting upon virgin or depleted bottom.

Other and more complex plans of oyster-culture are employed in the countries of Europe, but have not yet been adopted in the United States. There are indications, however, that in certain portions of our oyster belt it may be necessary to follow some method of pond culture, not so much for the purpose of growing the oysters, but to fatten them for market. Should the feasibility of this be demonstrated under the conditions prevailing in the United States, a vast increase could be made to our oyster supply, as it is a well-known fact that certain large areas are capable of raising oysters which they rarely fatten and for which, therefore, no market can be found.

By some modification of pond culture it may also be possible to raise seed oysters in regions in which few or none are now produced, thus adding another considerable item to the wealth-giving powers of our coasts.

These several subjects are treated under their appropriate headings in the following pages.

PLANTING WITH SEED.

PRELIMINARY CONSIDERATIONS.

Preliminary to planting, the first essential is to determine whether private rights in oyster bottoms are recognized by law or countenanced by public opinion. Unless the planter is assured of exclusive ownership in the product of his labor and enterprise he will find more profit and peace of mind in devoting his energies to some other calling. Unless the law, backed by the public sense of justice, makes the theft of oysters from planted grounds punishable like theft of any other kind, it will be impossible to expect success in oyster-planting. Very remarkable views obtain in some places concerning the right to property beneath the sea, and in such places the planter will find it impossible to protect his interests.

Having determined that his rights in his riparian property may be successfully maintained, the next step is to select beds that present the proper conditions of temperature, density, bottom, food, etc.

Temperature.—If it is desired to establish a self-perpetuating bed the temperature should rise for a considerable time during the spawning period to between 68 and 80 degrees. If it be desired to merely increase the size of seed oysters obtained elsewhere, it is not necessary that the temperature should ever rise so high, although, as a rule, warm waters induce more rapid growth. The range of temperature to which adult oysters are subject will be seen on page 280.

Density.—The density should be above 1.007 at least, and the beds should be so located as not to be subject to the influence of freshets which would reduce the density below that degree for any length of time. A density over 1.023 is not advisable, although oysters grow in places in a somewhat greater salinity. (See p. 281.)

Bottom.—The character of the bottom is the most important consideration, and it is probable that, upon our coasts, the other conditions will be fairly met in any locality where suitable bottom is available. The selection should be made with care, and the methods employed should be adapted to the character of the ground. Otherwise the planter may be put to labor and expense without return.

Hard, rocky bottom is in general unsuited for the cultivation of the oyster. Such ground, while affording facilities for the fixation of spat, does not supply sufficient food to cause a rapid growth, such as is desired by the planter, unless there is abundant muddy bottom in the vicinity. Heavy clay is open to the same objection. Loose sand is liable to drift and bury the oysters, and deep, soft mud is absolutely fatal, as it allows even adult oysters to sink to such a depth that they are smothered.

The best bottom consists of a firm substratum, above which is a layer of soft flocculent mud. In Long Island Sound, firm, sandy bottom is often used with great success. The oysters do not grow so rapidly there, however, as they do upon the soft mud of Jamaica Bay and other places on the south shore of Long Island.

Food.—The question of food is a *sine qua non* in oyster-culture. Without a supply of suitable and proper food it is useless to attempt the growth of oysters. As a general rule, it will be found that where the proper conditions of temperature obtain the vicinity of a muddy bottom will be well stocked with the minute organisms upon which the oyster feeds. Reliance upon this fact, however, is placing dependence upon a "rule of thumb," never a profitable method where more accurate and scientific information can be obtained. Oystermen usually determine the best growing and fattening grounds by actual experiment, a proceeding often entailing the wasteful expenditure of time and capital, and the small cost which would be involved in making a preliminary biological survey would be, in most cases, well expended. The currents may be such as to carry the food organisms away, or for other reasons beds, apparently well situated, may be lacking in food, a fact usually not discovered until time and money have been wasted in experimental planting.

Marking bed, etc.—The boundaries of the planting-grounds should be marked with stakes in such a way that each planter will have no difficulty in distinguishing his own ground from that of his neighbor. In order to recover the boundary, should the stakes be carried away by storms or ice, it is usual to have ranges locating the most important marks, such as those at the corners of the beds, these ranges being either conspicuous natural objects, buildings, etc., or, preferably, signals erected especially for the purpose. In deep water, or upon bottoms where stakes can not be driven or held, buoys are commonly used for locating the beds. Some of the States have laws regulating more or less strictly the manner of describing and marking the private oyster-grounds, and to avoid trouble and disputes these should be strictly complied with.

It should be remembered that it is more difficult to lay out and mark areas beneath the water than upon the land. It sometimes happens that the planter is able to get control of an entire cove or brackish-water creek, in which case the question of marking the beds and of protecting them from poachers is much simplified. In some places it is customary for owners to subdivide their beds for purposes hereafter mentioned, and such subdivisions may be marked in the manner adopted for indicating the boundary of the right.

PREPARING BOTTOM.

Having located and marked the beds, the ground should be prepared for planting. In places such as San Francisco Bay, where the oysters are placed on beds which are more or less exposed at low tide, this usually consists of clearing away the snags and other debris at low water and leveling off the mounds and filling up the hollows. If it is necessary to build stockades to protect the oysters from fish, this should also be done before planting is begun, as otherwise the bed may be ruined before it is fairly planted.

In deeper water the clearing up of the grounds is usually done by means of the dredge, all debris being carefully removed. This work is best performed by steam, the larger planters owning vessels and the smaller ones hiring them for the purpose. The work with sailboats is more laborious and less rapid.

If the bottom is firm, or if there is a firm substratum an inch or two below the soft surface-layer, no further preparation is needed. When there is a soft mud of some depth, however, it is absolutely necessary that the surface be prepared in some way which will prevent the oysters from becoming completely submerged and suffocated in the soft deposit. This is usually done by distributing over the soft places various hard substances, which, resting upon the mud, give it a firm surface upon which the oysters may repose in safety.

In France, where the lack of suitable grounds frequently requires the use of very soft bottoms, this difficulty is sometimes overcome by the expensive means of macadamizing the bottom with gravel and clay. While this, of course, forms an excellent bottom, hard and smooth, it can only be used on grounds exposed at low tide.

American planters usually provide a firm surface by strewing oyster shells, clam shells, gravel, or sand over the bottom in such quantities as to have the desired effect. When shells or gravel are used the double purpose is often served of preventing the submergence of the adult oyster in the mud and offering a place of attachment for the spat. In certain places sandy and gravelly material resulting from dredging for harbor improvements has been utilized for this purpose, and much soft bottom, before valueless, has been made to yield a profitable return to the planter. Such material can often be obtained at a very small cost, sometimes merely for the expense of transportation to the beds.

In surfacing, care should be exercised that the firm layer be deposited uniformly, as otherwise the muddy bottom will be exposed in places and the oysters falling thereon in planting will be engulfed in the mud. Plenty of material should always be used, as it is poor economy to spend money for work and material which is insufficient to accomplish the end sought. The exact amount necessary will depend upon the character of the bottom. Where it consists of a very deep, pulpy or flocculent deposit it is useless in most cases to attempt to improve it, as the surfacing material will sink almost as fast as it is deposited. In places perhaps this might be overcome by the French system of macadamizing, but as more suitable bottom is abundant on our coast such an expensive procedure would be unnecessary.

When the bottom is properly surfaced with coarse sand or gravel it does not as a rule require another coat for four or five years. When there is a rapid deposit of mud it will, of course, soon become covered up, but a location where this takes place with much rapidity should perhaps be better left alone, as the seed oysters are liable to suffocation by the deposit of material upon them. A strong current will prevent the deposit and keep the surface scoured after it has been once prepared.

SEED.

After the ground has been thoroughly prepared according to its requirements, the next consideration is the actual planting of the oysters. Planters follow one of two methods, as their interests and experience may dictate; they either plant seed oysters and raise them to an adult or marketable size, or they use cultch to catch the spat, which may be either sold as seed or retained until it has grown. The former method is perhaps the simpler and more uniformly successful in most localities, and it will be, therefore, first discussed.

Seed oysters are young or immature oysters suitable for planting. They vary in size from minute "blisters" up to well-grown oysters, which will be ready for market in six months after they have been bedded. In most cases they run in size between 1 and 1½ inches, or from about the size of a silver quarter up to the size of a silver dollar.

The seed is obtained either from planters who make a specialty of raising it, or from the natural reefs, or from various places along shore where there may be an abundant set of spat. In certain localities gravel beaches often show a strong set in the area between tides, where it may be collected at low water, or beyond low-water mark, where it may be dredged or tonged from boats. In some parts of Long Island Sound there is an extensive fishery for seed oysters in localities such as described.

Some planters collect seed for themselves, but most of them prefer to buy from those who make a specialty of that branch of the industry. The price varies in different localities and with the character and size of seed, from 10 cents to \$1 per bushel. The larger growth of seed brings a better price than the smaller, as it takes a shorter time to bring it to maturity and it is less susceptible to the attacks of enemies. The care with which the seed has been sorted is also a prime factor in the cost. Seed, just as it comes from the beds, contains much besides oysters; sometimes as much as 75 per cent consisting of old shells, sponge, and other rubbish. Though such material may be obtained at a low price, it is not generally regarded as economical, as a larger quantity must be planted than when good seed is used, the bed is littered with undesirable rubbish of all kinds, and is liable to become stocked with enemies which will cause trouble in the future. The uncultured seed is liable also to grow into rough oysters, crowded into bunches and of undesirable shapes, which bring a smaller price when put upon the market.

When culled stock is selected—that is, seed consisting of separate individuals of good shape and uniform size—it is said to generally give satisfactory results. It is free from rubbish and enemies, and, being vigorous, it is able to at once avail itself of such advantages as the beds possess and its growth is correspondingly rapid. The oysters being separate from the beginning, when they reach maturity they are shapely and in good condition.

It has sometimes happened that good results have followed the sowing of spat-covered shells purchased from the canneries, but this method is precarious unless the shells are used in the process of spat-collecting to be explained hereafter.

The locality whence the seed is derived is also important. Oysters taken from a warm region, where food is plenty and growth rapid, to a colder region, where food is more scanty, are, it is stated, not always successfully acclimated unless the transfer is made when the oyster is very young. Some planters say that when southern oysters just about to spawn are taken to Long Island Sound, the generative products are not discharged and many of them die in the course of the season. The seed obtained from southern "plants," however, is as hardy as that obtained from the "natives," from which it can not be distinguished in either appearance or growth. The planting of southern seed oysters was formerly an important industry in Long Island Sound, but it has been almost entirely supplanted by shell culture. Each spring a comparatively small number of Chesapeake oysters are set down, as they have been found to fatten earlier in the fall than the native stock. There is no complaint of excessive mortality among the "Virginia plants," and it is claimed that they spawn freely in summer even if bedded in the preceding spring.

SOWING THE SEED.

The seed oysters are usually scattered over the beds from boats or scows. Care should be exercised to get them as equally distributed as possible, as experience has shown this to be advantageous to their growth. When thrown into heaps many are prevented from getting a proper supply of food, and the crowding may also cause irregularities in the shape of the shells, thus reducing their market value.

In order to secure a proper distribution over a bed, it may be roughly marked out into areas, say 50 feet square, in each of which an equal amount of seed should be planted, by scattering it broadcast with shovels or scoops from the boat or scow. In subdividing the bed a few rough stakes or buoys may be used as temporary guides.

Another method is to anchor the boat upon the bed, distribute the required amount of seed over the area which can be reached by throwing the oysters from a shovel, and then move on to the next station, where the boat is again anchored and the operation repeated. When the scow is emptied a buoy or stake may be used to mark the position of the last deposit, and operations can be resumed from that point with the next boat load. By such means the seed is rapidly and evenly spread over the bottom.

In planting on extensive beds where steam power is used the seed is distributed from scows, which are slowly towed back and forth, while a gang of 8 or 10 men shovel the oysters overboard as rapidly as possible. That is the most rapid and economical method, and is the one usually employed on the deep-water grounds of Long Island Sound.

It is not well to deposit the oysters very thickly. About 300 to 600 bushels per acre appears to be the usual amount in most places. The ground will, of course, support a larger number of yearling seed, but as they grow larger there will be more or less crowding and the demand for food will be greater.

In certain places where oyster-planting has greatly increased within recent years it is found that the oyster neither grows as rapidly nor fattens as readily as formerly, and it is supposed by many that the quantity of oysters has outgrown the ability of the region to supply them with food. The matter has not yet been investigated and the facts in the case are not definitely known, but the theory proposed is a plausible one to account for the difficulty with which the planter is beset in fitting his stock for market. It is well known that when the seed is sowed too closely upon a given bed the oysters grow and fatten more slowly than upon less thickly populated ground, and only in waters exceptionally rich in food can the quantity of seed planted exceed with safety the number of bushels stated. When the seed is sowed too thickly there is also a tendency to distortion from crowding.

WORKING THE BEDS.

When seed oysters of good quality are used it is generally not regarded as necessary to "work the beds," although care should be taken to prevent, if possible, the inroads of enemies. The various methods of attempted protection from enemies have been discussed in another connection.

It is sometimes advantageous to dredge over the planted beds to remove debris, seaweed, etc., which has drifted upon them, and which of itself and by the collection of sand, etc., would smother the oysters if allowed to remain. If the bottom is not perfectly fixed it may be necessary to shift the oysters during their growth in order to prevent "sanding," i. e., being covered with sand, etc., from the drifting bottom.

While oysters grow most rapidly upon or near muddy bottom, they are often in some respects objectionable if placed upon the market directly from such beds. Some planters, therefore, transplant them to hard bottom for several months before sending them to market, it being said that this improves their flavor and appearance by causing the muddy matter in the gills and mantle cavity, as well as in the intestine, to be gradually cleared out and disgorged.

In parts of Long Island Sound many of the planters take up a portion of their stock in spring and transplant it to such ground as may be available in the bays and harbors. Such transplanted oysters fatten and grow more rapidly than those left in the deeper water; the difference in condition is manifest to even the inexperienced, and a higher price is obtained and a more ready market found for the "harbor plants." The area available for this purpose, however, is insufficient to permit of the transplanting of more than a very small proportion of the "Sound stock."

The bottom from which the oysters have been shifted is, of course, cleansed of rubbish when the oysters are taken up and may be at once utilized for fresh seed. Some oystermen prefer to let it lie idle for a year, supposing that this increases its fitness for a further crop, but there appears to be no good reason for this, though it may be that this course permits of a recuperation of the food supply on the fallow beds.

The length of time during which the plants are allowed to lie depends upon the location of the beds, as affecting the rapidity of growth, upon the size of the seed planted, and upon the judgment of the planter. In many places "yearling" seed will be ready for the market in two or three years after being planted, i. e., when the oysters are 3 or 4 years old, but in exceptionally favorable localities, such as Jamaica Bay, Long Island, such seed is said to grow to marketable size in six months or a year. In some places it is said to now take a year longer for the oysters to mature than when planting was first practiced.

As large oysters bring a better price than small ones, it generally pays to allow them to grow for a year or two after they reach a marketable size, but this is a matter which the planter will determine for himself, as conditions vary with the locality.

As the planter generally wishes to harvest a portion of his crop each year, it is customary to divide the beds into sections, which are planted in successive years in such a manner as may suit the plan of operations of the particular grower concerned.

PLANTING WITH CULTCH OR STOOL.

PRELIMINARY CONSIDERATIONS.

This method of oyster-culture is that which was first adopted, and to it and its modifications we must doubtless look for future growth in the oyster industry. The method of planting seed oysters improves the size, shape, and flavor of the plants, and to some extent increases the quantity of oysters available for the markets, but, nevertheless, many of those which are raised from seed derived from the natural beds would have reached a marketable size if left to remain. Moreover, the natural beds are now being depleted at a rapid rate by the drain which has been made upon them. Not only are they compelled to supply oysters for market, but the young growth is now carried off to be planted elsewhere. As the number of spawning oysters on the beds is reduced and as the spawners become more scattered, the reproductive capacity of the beds is being lowered, and at the same time the removal of both oysters and shells leaves fewer points of attachment for the young spat. As the seed-producing power of the natural beds becomes reduced from these various causes, the planter must have recourse to other methods for obtaining his set of young oysters. Fortunately, there is a well-tried method which may be adopted. The oystermen long ago noticed that under certain conditions not only did natural objects of various kinds become covered with young oysters,

but other objects accidentally dropped overboard would often, when recovered a few weeks later, show a heavy set of spat. Naturally they began to throw objects into the water for the express purpose of collecting the spat and thus increasing the amount of seed available, and from this beginning the present system of spat-collecting now in use in our waters was developed.

For this method of planting it is, of course, essential that there should be in the vicinity of the beds spawning oysters, either of volunteer growth or planted, and that the temperature of the water should be between 68° and 80° F. during a period of some weeks' duration.

PREPARING BOTTOM.

The bottom used for this method of cultivation should be firmer than that which will suffice for bedding well-grown seed, though soft bottom may be prepared so as to be satisfactorily used. If the bottom is very soft it may be overlaid with gravel or sand in the manner before described (p. 300), and upon this the collectors or cultch may be deposited. In a moderately soft bottom the cultch can be applied without previous preparation other than to clear the ground of all debris which would interfere with working it. Hard, gravelly bottom in shoal water, which may be of little use for the raising of adult oysters on account of the absence of food, may prove an excellent place for the collection of spat, and the same may be said of some places with a stiff clay soil.

One of the great difficulties in spat-collecting is to avoid the deposit of sediment upon the cultch, as an amount of sedimentation which would have no effect whatever upon the adult oyster would prove absolutely fatal to the young spat. At the time of attachment the infant oyster is about one-ninetieth of an inch in diameter, and the deposit of a very slight film either before or immediately after the falling of the spat would be sufficient to cause its suffocation. It will be seen, therefore, that a soft bottom upon which the large oysters will thrive, or an amount of sedimentation which may favor the rapid growth of the adults from the food matter which it contains, will effectually prevent, in many instances, the cultivation of spat.

CULTCH, COLLECTORS, STOOL.

By these terms is understood any firm and clean body placed in the water for the purpose of affording attachment to the spat or young oyster. A great variety of objects have been suggested and used for this purpose, both here and abroad, and some of these will be now discussed.

Oyster shells.—In this country oyster shells are the oldest and most generally used form of cultch. They are usually merely spread upon the bottom, being thrown broadcast from boats in the manner which is described for planting seed oysters (p. 302). When the bottom is sufficiently hard to prevent the submergence of the shells, it is customary to spread them as uniformly as possible over the ground, so as to

offer the largest available area for the attachment of the spat. Where the bottom is so soft, however, that the shells would tend to sink before the young oysters have reached a size to enable them to successfully combat such conditions, it is preferable to surface the bottom in the manner described for planting seed oysters, or the shells may be thrown over so as to fall in flat heaps, those at the base forming a foundation support for those above, leaving only the upper shells available for the set of spat, those below soon becoming buried in the mud.

Shells may be planted in all depths of water with equal facility. They are cheap and readily obtainable in all oyster regions. Clam and scallop shells are also used in the same manner. The quantity required to properly "shell" a bed depends upon the nature of the bottom. When the ground is soft a larger number is necessary than upon hard ground, because in the former case many become buried in the mud or covered up by the others, whereas in the latter instance they all become available as collectors.

Upon soft ground some planters, instead of preparing the bottom with sand or gravel, apply a layer of oyster shells a couple of months before it is time to distribute the cultch proper. Those first applied sink a short distance into the mud where they become suspended so as to form a more or less solid substratum which supports the cultch applied later. A bed so prepared simulates the natural banks, which in most places overlie a mud bed that, in its upper portions, has acquired some consistency and firmness by the shells lying buried in it.

After a muddy bed has been shelled for a number of successive years it will be found to become gradually firmer. Each year some of the planted shells become covered up and are left remaining when the oysters are removed and thus it happens that the bottom of a well-handled planting-ground improves with use.

When the oyster or clam shells are thrown from the boats they will be found to fall so that the convex side rests upon the bottom. There is nothing very remarkable or inexplicable in this, as it is entirely in accordance with the ordinary laws of the resistance of fluids to the passage of a solid body through them; but in sowing the shells, however, it is important that they so fall. In most cases, if such cultch be examined, it will be found that nearly or quite the entire set of spat is upon the convex or lower side. As the shell falls its greatest convexity rests upon the bottom, its edge being held clear of the mud in the form of a projecting ledge, sheltered on its under side from the suffocating sediment deposited upon the upper surface. In ordinary situations perfectly flat pieces of tile, shale, etc., would be vastly inferior to shells, for the lower surface would lie close to the bottom while the upper would become covered with a muddy deposit from the water, between the two the young oyster having but scant opportunity for fixation.

It has been observed that when shells and gravel are spread upon the same beds the former usually catch the larger amount of spat, especially in years in which there is but a moderate set. The planters

and oystermen attribute this to the fact that the shells project a greater distance above the bottom and that therefore the fry come into contact with them first in their descent for attachment, but as the set is mainly upon the convex side of the shell and therefore *underneath*, it will be seen that the true explanation of the superiority of the shells is that given above.

The quantity of shells sowed upon any given bottom will depend upon the judgment of the planter, the general rule being to sow more on soft than upon hard bottom, for the reasons before stated. The usual quantity appears to be from 250 to 500 bushels of shells per acre, most of the planters using about 400 bushels per acre, except upon very muddy bottom; but in Long Island Sound there is an increasing tendency to use greater quantities.

In some places the shells may be obtained for the cost of transportation. This was the general rule years ago, but with the increase in planting a charge of from 2 to 5 cents per bushel is now made for them. Many planters who operate canneries or ship "shucked" oysters have ready at hand an abundant supply of shells for use as cultch. The cost of spreading ranges from $\frac{1}{2}$ to 2 or 3 cents per bushel, according to the location of the beds and the cost of labor, etc.

The principal objection to the use of oyster shells is that they are of such large size that many more spat attach themselves than have room to grow and, at the same time, they are so strong and massive that it is difficult to break them in pieces so as to allow for the expansion of the young. As a consequence many young oysters which have successfully passed through the early stages of their fixed conditions are smothered or overgrown by their more vigorous fellows, which are themselves distorted by the crowding to which they are subjected. Many are thus wasted which would, under better conditions of attachment, have grown to a marketable size. (Plate IX.)

For the reasons mentioned scallop, "jingle," and other fragile and friable shells (plate XVIII, figs. 1 to 6) are, when they can be obtained in quantities, to be preferred. Such shells will break up under the mutual pressure exerted by the oysters during their growth and the latter will then be liberated from the bunches and will tend to grow into shapely and desirable forms, with a smaller rate of mortality. When the currents or waves are very strong such frail shells as jingles may prove too slight to withstand their action and the planter using them may find, to his surprise, that much of his cultch has been carried away. Upon some portions of the Pacific coast it is said that the wave action and the currents are so strong that the light, thin shells of the native oyster are swept away or thrown upon the shore. Otherwise, and for the reasons before stated, these shells appear to be well adapted to the process of sowing and they can also be obtained cheaply and in large quantities.

Other methods of using shells.—It has been recommended or suggested that shells of various kinds could be strung upon wires, etc., and suspended in festoons from stakes planted in the bottom. This would, of

course, prevent their submergence in places where the mud was very soft, but as each shell would have to be separately handled it will be found that this method is too expensive to be warranted by the present condition of the oyster business. Another method of utilizing oyster shells as cultch is treated of in connection with the subject of pond culture (pp. 322-330).

Gravel and pebbles.—This is a form of cultch which is much favored by the planters in some parts of Long Island Sound, its principal advantages being the small size of its constituent particles and its cleanliness. As a rule the pebbles are so small that but few spat fix themselves to each (plate XVIII, fig. 7) and, consequently, there is little or no danger of crowding. Not only do a larger proportion of the young oysters survive their infancy, but they develop into deeper, more regular shapes, are free from bunches, and, consequently, bring a higher price in the markets. Where the trade in "shell stock" is large the shape of the oysters is a consideration of importance, but where only shucked oysters are shipped irregularities in shape are less undesirable. The gravel is more cleanly than shells, because it is not attacked by the boring sponge, which gives rise to much of the debris found upon the oyster-beds. There is also less liability to the introduction of oyster enemies than when shells are utilized.

The bottom used for obtaining a "pebble set" must be firmer than that which will suffice for the sowing of shells, the gravel being heavier in proportion to its surface and therefore more liable to sink. It also presents less surface on muddy bottoms, where the pebbles will soon become buried to their equators, and if there is any sedimentation there is left no surface available for the attachment of the fry. Rounded, water-worn pebbles are usually preferred, such offering more surface free from sediment than flat stones. They afford, perhaps, the best form of cultch for use upon firm bottoms, when there is sufficient current to prevent the rapid deposit of sediment. It is observed that gravel beaches, when these conditions obtain, are often the most valuable of natural spatting-grounds. In some places gravelly material dredged from harbors and channels during the improvement of waterways is used to advantage. Crushed stone, averaging about the size of a walnut, is also an excellent collector. Gravel or crushed stone is generally more expensive than shells, costing from 5 to 7 cents per bushel. The custom is to sow from 25 to 30 cubic yards (from 500 to 600 bushels) per acre when used alone, but a smaller quantity if shells are also used.

Scrap tin, tin cans, etc.—In some places old tin cans and scrap tin of various kinds is found to give good results when used as cultch. It has the advantage of becoming corroded and gradually dissolving in the salt water, thus releasing the young oysters before they begin to crowd one another and allowing them to grow into well-shaped adults. Moreover, as the cultch each year disappears in solution, there is no debris from this source to litter the ground and to cause the expense of culling. It seems that, in the form of old tin cans, this type of cultch

might have some advantage on muddy bottom where there is a rather rapid sedimentation. Such cultch is light in proportion to the surface presented, it would not readily sink, and the upper half of the interior, and to some extent the lower half of the exterior would present surfaces protected from sedimentation upon which the young oyster could lodge itself. By the time the can disintegrated the oysters would no doubt be sufficiently grown to withstand the action of the mud. The tin is distributed over the bottom as in the case of shells and gravel.

Brush for soft bottom.—Where the bottom is so soft that ordinary methods can not be used, it will sometimes be found that fagots and brush make most efficient collectors. The brush is thrust firmly down into the mud in such a manner that the small branches are at some distance above the bottom. They will offer a large surface to the water, a slight current will tend to keep them free from destructive deposits of sediment, and in water well charged with the swimming fry will almost certainly yield a full set of spat. The brush is lifted at the proper time by means of a crane or boom and windlass. This method was used with some success at the town of Groton, Conn. The seed was left to grow to a marketable size on the brush, but owing to the liability of the large oyster to drop off into the soft mud below, it was sold as soon as possible.

Brush, straw, etc., may also be used by collecting the material into bundles, sheaves, or fagots, which may be anchored by stones or suspended from stakes. As it is usually unnecessary to resort to such very soft bottom, it will be found in most cases that shells, gravel, or scrap tin will be more serviceable and satisfactory. Brush collectors would be difficult to use in regions of violent wave action.

Other collectors.—Many materials have been suggested as suitable for collectors, but the foregoing appear to be the only ones which have proven practical on a large scale in our waters. Tiles and roofing slates arranged in various forms have been found satisfactory by European culturists, but are apparently not adapted to use here where labor is high and oysters are cheap. These collectors will be discussed in another connection. Pieces of bricks, broken pottery, and similar materials may suggest themselves to the planter as local substitutes for shells and gravel. Hard-wood chips and bark might prove useful, but are hardly to be recommended.

COATING CULTCH.

To overcome the difficulty, which has been mentioned, of the set upon collectors being so dense as to interfere with its subsequent growth, it has been proposed to coat the cultch with some material which will flake off, either under the mutual pressure exerted between the growing oysters, or when it is scraped with a suitable instrument. This device was apparently first used in France, where it was adopted to avoid the theretofore necessary breakage of the tile collectors. The coating is detached from the tiles with a chisel-shaped instrument, somewhat resembling a putty knife.

Apparently this method has never been used in our waters, but where it is necessary to use oyster shells for cultch it might perhaps be applied to advantage. In this case the fry could not be economically detached by hand, but there is little doubt that the growing oysters would automatically liberate themselves. The coating used in France consists of a mixture of sea water, lime, and sand, or hydraulic cement, "stirred to the consistency of thick cream." Various formulæ are used by different culturists, three of them being as follows:

1. One part quicklime, 3 parts fine sand.
2. One part quicklime, 1 part fine gray mud.
3. First a light coating of quicklime, and, after drying, a coat of hydraulic cement.

The coating should be such as not to readily wash off, yet sufficiently brittle to flake under the mutual pressure exerted between the growing oysters, and about $\frac{1}{5}$ -inch in thickness.

For convenience in coating, Dr. Ryder recommended that the shells be placed in a wire basket and dipped into the cement vat, the mixture being then allowed to set before the shells are used.

GENERAL CONSIDERATIONS ON SPAT-COLLECTING.

Whatever may be the character of the cultch, it should invariably be clean and without any surface deposits which might tend to prevent the fixation of the spat. For the same reason the cultch should not be placed upon the beds long before the season for setting.

In almost any body of water, except where the currents are swift, there is more or less sedimentation, and it is obvious that the shorter the time that a body is exposed to such action the thinner must be the deposit. If the cultch is placed in the water long before it is needed the deposit of sediment is often so thick as to stifle the young oyster, but on the other hand if the time be well chosen a practically clean surface is presented and a good set is more likely to reward the planter. The latter's aim should, therefore, be to determine as nearly as possible the time when the maximum amount of spawn falls, and to so regulate his operations that his cultch is laid down but a few days before. The time will vary somewhat with the locality, and if there is no local experience to guide the beginner he may be compelled to experiment a little to find the most favorable time for exposing his collectors. It should be remembered that while the spawning season in any given locality extends over a number of months, the majority of the oysters spawn within a more circumscribed period, usually about midway between the two extremes.

If the time at which the collectors are exposed be well chosen, and the location of the beds properly selected, the planter may or may not obtain a good set. Sometimes one bed will show a strong set, while its neighbor appears to have been entirely passed over by the fry. Often the cultch in one part of the bed is thickly incrustated with spat, while another portion, apparently equally well located and upon which an

equal amount of care has been expended, will prove utterly sterile. While in many such cases the causes are not known, yet the experience of planting has thrown some light upon the matter. It is known that cultch can not be thrown down at random with any strong expectation of success. The water is not everywhere charged with the swimming fry, and the experience of planters has shown that they are often distributed in streaks or belts, which appear, to some extent, at least, to be conditioned by the currents. If cultch be placed in a current it will, other things being equal, be more likely to catch a set than when in still water. Even a strong current does not appear to interfere with the fixation of the young, and as it brings a greater body of water into contact with the collecting surface, some of it is more likely to contain fry at the stage for fixation.

It is also obvious that the water is not likely to contain many fry unless there are spawning oysters in the vicinity, and it is, therefore, the part of wisdom to locate the collectors in the vicinity of natural or artificial beds containing mature oysters. Even where the oysters are so scattered as to hardly pay for working, it will be usually found that there is sufficient spawn fertilized to provide considerable seed if it be given proper facilities for attachment. For reasons readily seen, it will be advantageous to locate the collectors so that the predominating current sweeps from the spawning oysters toward the collectors. In some localities it will be found that the entire set occurs in the tidal zone; that is, in the area between low and high water. The reason for this is not yet fully understood, but if it should prove to be because the embryo oyster is lighter than the dense sea water, and therefore can not sink to the bottom, or because the sedimentation is too rapid below low-water mark, or almost any other reason except the softness of the bottom, then the cultch must be confined to the area between tides if it is to be effectual as a collector of spat. The most careful and uniformly successful oyster-culturists do not depend entirely upon the spawn derived from neighboring beds, but usually distribute over the spatting-beds a number of mature spawning oysters in the proportion of 30 to 60 bushels per acre, these being usually put down before the cultch, so that the oysters will become to some extent acclimated before the spawning season.

As the cultivated area increases it becomes unnecessary to use so many brood oysters, and in some places where they were formerly used reliance is now placed solely upon the floating fry derived from the mature oysters on neighboring beds. Upon theoretical grounds it would appear to be preferable not to scatter these "mother oysters" too widely. There would seem to be greater certainty of fertilization when the oysters are grouped, and there are ample time and superior facilities for securing distribution over the beds in the embryonic condition. The embryo exists for a period as a free-swimming form, and during that time it may be carried considerable distances by its own exertions

and by the action of the currents. On the other hand, the eggs, and especially the spermatozoa, will probably die unless they fulfill their destiny within a much shorter period, and the sooner they are brought into contact with one another the better, and the smaller the bulk of water through which they are at first distributed the larger the number which will accomplish successful union.

Upon these considerations is based the advice not to scatter the "mother oysters" too widely. Fifty bushels of oysters, 250 to the bushel, scattered evenly over an acre would allow one oyster in every 22½ linear inches in each direction, plenty near enough if they were to all spawn at one time, but it must be remembered that the proportion ripe at any one time is not so large, and there is a possibility of all of the oysters over a considerable space being of one sex.

The "mother oysters" used for this purpose are preferably obtained from the neighborhood of the planting-ground. It has been remarked in another connection that transplanting mature oysters, especially from a warmer to a colder region, may have the effect of checking the development of the genital products, and Dr. Ryder has commented upon the fact that the spermatozoa of ripe oysters are killed by being changed to much denser or warmer water than that in which they have been living. The endeavor should be, therefore, to study the conditions on the planting-grounds, and to procure the spawners from beds as nearly as possible similar in the conditions of temperature and density. Where this consideration can not be closely followed, as for instance in the shipment of eastern oysters to places on the Pacific Coast, the brood oysters should be sent during the fall preceding the season at which the cultch is to be put down. They will then be pretty well disgorged of their ripe genital products and the time intervening before the next period of sexual activity will probably be sufficient to acclimatize them.

WORKING THE BEDS.

Many planters are content to allow their beds to remain unworked until they are ready to market their crop, whether this be one, two, three, or more years. In some instances this may be satisfactory, but often, and perhaps usually, it is better to go over the beds with tongs or dredges, cleaning up the debris and separating the oyster clusters or even in some cases removing the seed to localities in which the conditions are more favorable for rapid growth, for in many cases the best spatting-grounds are not the most favorable for subsequent growth.

The stage at which the planter will find it most profitable to sell his oysters will depend much upon circumstances. Sometimes the set of spat will be greater than could be advantageously grown upon the area covered and some of it could be manifestly removed to advantage. Some planters find it more profitable to sell their oysters as seed, thus receiving quicker returns for their investment and also lessening the possibility of losses due to the appearance of enemies or the advent of

untoward conditions. In many cases it will pay the planters to specialize, some raising seed for sale to others who devote their capital and enterprise to the work of raising the oysters to a marketable size.

Even if the oysters are to be left upon the spatting-bed, it is often better to work over the ground during the first year, removing the debris and breaking up the clusters of young oysters, so as to insure a greater survival and superior shape. As has been already mentioned in treating of the planting of seed, it is often advisable to shift the oysters to other ground during the last few months before marketing in order to fatten them, improve the flavor, and cause the gradual disengagement of mud from the intestine and mantle chamber.

A keen watch should be kept at all times to detect the presence of enemies, some of which may be with more or less success combated by the methods mentioned on pp. 313-319. The spatting-beds are especially subject to the attacks of various enemies which find in the vast numbers of thin-shelled young an abundant and readily obtained food supply. The starfish, especially, at times appear in vast schools or swarms, and often a bed is almost completely destroyed before the planter is aware of what is taking place.

PROTECTION FROM ENEMIES.

In the case of most of the enemies of the oyster it is impossible to indicate efficient means of protecting the beds from their inroads. The impossibility of knowing at all times the exact conditions prevailing upon the bottom, the suddenness with which many of the enemies appear upon the beds, and the insidious character of their attacks all add to the difficulty which the planter finds in preventing the destruction of his property.

PROTECTION FROM FISH.

It is possible to protect oysters in shallow water from the attacks of fishes by surrounding the beds with palisades of stakes driven into the bottom at sufficiently close intervals to prevent the passage of fish between. Upon the Atlantic coast the inroads of fish are not sufficiently formidable to require such protection, although the drumfish causes some loss to planters in the vicinity of New York. Upon the Pacific coast, however, and especially in San Francisco Bay, stockades are necessary to prevent the absolute destruction of the planted beds by the stingray, the stakes being driven at intervals of about 4 inches. It is necessary to keep the inclosure in good repair, as a school of rays entering through a small breach may utterly ruin the bed.

PROTECTION FROM STARFISH.

Many methods have been suggested for combating this destructive enemy of the oyster, most of them being of no practical utility. Barriers are utterly useless, for the very small starfish are among the most destructive and the largest ones are able to pass through an orifice of

such small dimensions that it is impracticable, for manifest reasons, to build a barrier so close in structure as to exclude them. Some attempt has been made to catch them in traps, made of laths and baited with fish, crab meat, clams, etc. These traps are constructed and tended like lobster pots, and while it has been found that the starfish can be taken through their agency, the method is too laborious and inefficient to be used for the protection of extensive beds. Various devices for catching starfish have been patented from time to time, but none of them appear to have been of practical value.

Upon the theory that the starfish prefers the mussel to the oyster as food, it has been proposed to surround the oyster-beds with a growth of mussels with the expectation that the starfish will not pass over the mussel bed to obtain the less desired oysters. Investigations in Long Island Sound show that this expectation is not realized in practice, and, moreover, in favorable locations, the growth of mussels is so rank that they themselves become a menace to the planter by overgrowing his beds and suffocating the oysters. This method of protection is also wrong in principle, for by supplying the starfish with additional food we better its conditions and thereby aid in increasing its numbers.

For catching starfish some planters use the ordinary oyster-dredge, an implement which has some advantages when it is desired to cull the stock, but, in general, it involves unnecessary labor and also crushes and kills many young oysters. A lighter dredge of similar construction is also used, and on the shallow beds tongs may be sometimes employed to advantage.

The oyster-growers of Long Island Sound, who have had more experience in fighting starfish than those of any other section, find that eternal vigilance is the price which they must pay for even the comparative safety of their beds. The beds are closely watched and worked over with dredges and tangles. Tugs are kept more or less constantly at work, and all starfishes taken, either in the ordinary work of oyster dredging or during "starring," are carefully destroyed. Thousands of bushels are caught during the year and much money is expended in the work, the result being that many beds, through timely and unceasing attention, are saved from utter destruction. The tangles or mops employed are an adaptation of a device long used by naturalists for collecting spiny forms from the sea bottom, and their use in fighting the starfish was first suggested by the United States Fish Commission. They consist essentially of an iron bar to which small chains or wires are attached at intervals of about a foot, mops or bundles of rope yarn, cotton waste, or similar material being distributed at short distances along the chains. The bar is fastened to the ordinary dredge line or chain and is dragged over the bottom, being hauled in at frequent intervals for the removal of the starfish which have become entangled. Most of the tangles used in Long Island Sound have frames weighing from 100 to 150 pounds, and to prevent this heavy mass of metal from crushing small and thin-shelled oysters they are provided with a hoop,

12 or 14 inches in diameter, at or near each end of the bar. These hoops ride over the bottom like runners and the crushing surface is thus much reduced. The general construction of these tangles is shown in cut 2. The weight appears to be unnecessarily great, all that is actually required being that which is sufficient to hold the tangles upon the bottom when in motion, a condition which is largely insured by the sagging of the chain used in towing.

A vessel-owner at New Haven, Capt. Thomas Thomas, who has been very successful in "starring," uses a much lighter tangle constructed as follows: To a half-inch chain, about 8 feet long, stout wires 12

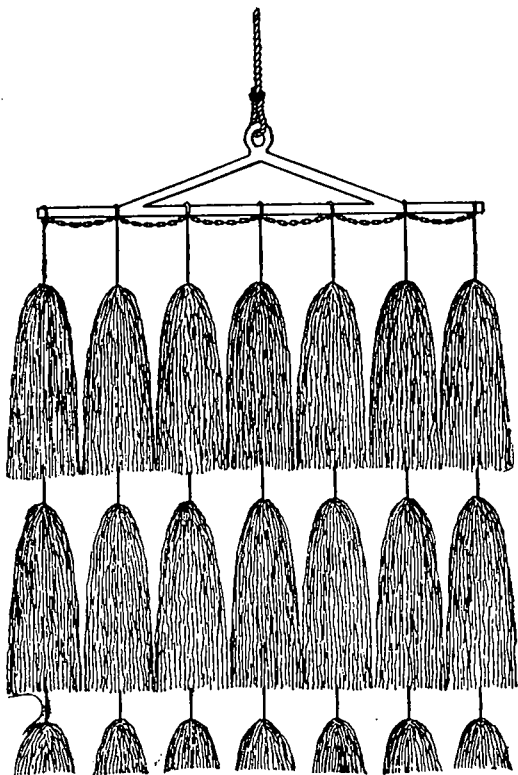

CUT 2.—Tangle.

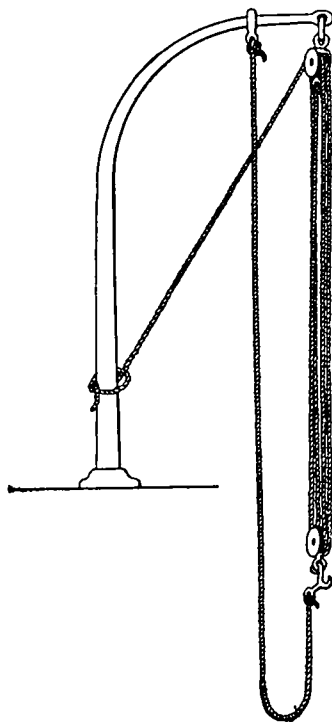

CUT 3.—Tackle.

or 14 feet long are attached at regular intervals, and to these wires are fastened mops or swabs of cotton waste. The chain is securely lashed to a bar about 7 feet long by $1\frac{1}{2}$ inches wide and half an inch thick, provided with a bracket and eye for the attachment of the drag chain, as shown in cut 2.

When in use this tangle covers an area about 7 feet wide and 12 feet long, forming a dense mat of snarled cotton threads. One of these is towed on each side of the vessel, like a dredge, and, sweeping over the bottom, entangles the starfish with which it comes into contact. The length of time during which the mops are towed depends upon the

abundance of the stars, being greater when they are few than when they are plenty. The starfish are killed by being momentarily immersed in a tank of boiling water, the bath being heated by a steam tap connected with the boiler. The tanks are about 7 feet long by about 18 inches wide and deep, and are located one on each side of the main deck, just inboard of the roller over which the tangle chain runs. To facilitate the immersion and handling of the tangles, a davit, with block and fall, is rigged on the hurricane deck over the tank, as shown in cut 3. A lanyard is rove through an eye welded to the back of the hook on the fall and the other end is fastened to the davit, its length being so adjusted that the hook is automatically tripped by the weight of the tangle when the hauling part of the tackle is eased and the mops lowered to near the surface of the water.

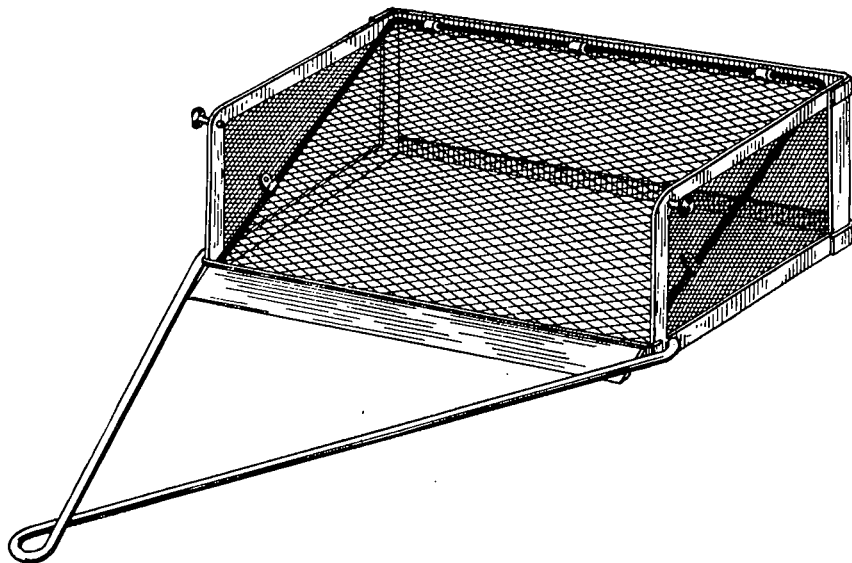

CUT 4.—Drill-dredge in position for work.

Some of the oystermen pick the starfish out by hand, but this is a slow and laborious process and, moreover, it is almost an impossibility to so remove all of the small ones. By using the arrangement just described the labor is lightened and the killing of the stars assured. By using a tangle on each side of the vessel one is always at work while the other is being hoisted. It is stated that upward of 100,000 starfish have been caught in a single day by a boat using the apparatus described. It is usual to work on the beds until not over half a bushel of starfish can be caught in a day, the beds then being considered safe, although at any time a host may arrive from a neighboring bed.

United effort on the part of the planters is necessary for success in fighting starfish. A neglected bed is, in a measure, a menace to others in the vicinity; for if starfish are left to multiply without hindrance they will move to neighboring beds as soon as they have exhausted the supply of food upon the first.

PROTECTION FROM DRILLS.

No method of proved efficiency has yet been devised for protecting oyster-beds from the inroads of the drill, but by systematic attention something could, no doubt, be done to lessen its destructive effects. In culling the oysters brought up in the dredge or tongs care should be exercised to destroy the drills. Most of them, however, will pass through the intervals of the ordinary oyster-dredge, and to obviate this a finer bag might be used within the dredge. This could be used especially in cleaning up the beds preparatory to planting. It should be remembered, in this connection, that it is possible to infect new grounds with the drill by its transportation thereto with the seed. The deep-water beds of Long Island Sound have of recent years suffered more and more from this pest, and it is supposed that this is accounted

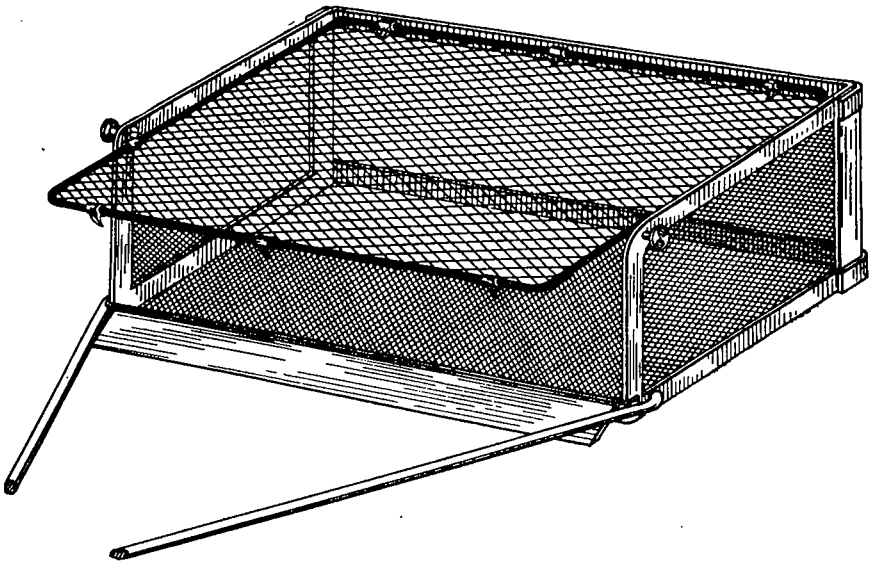

CUT 5.—Drill-dredge open for emptying.

for by the use of seed from the drill-infested beds in the less saline inshore waters. The use of tangles for catching starfish also, no doubt, aids in the distribution of the drills by dragging them from place to place.

The most promising method which has yet been proposed for catching this enemy is the invention of Capt. Thomas Thomas, of New Haven, Conn., who has applied for letters patent thereon. It consists of a rectangular frame of iron bars about 4 feet long, 2 feet wide, and 18 or 20 inches deep. The bottom, ends, and rear are covered with an iron wire screen, having a mesh of about half an inch, the top and front being left open. To the upper rear edge of the frame is hinged a stout wire screen of about 1-inch mesh, its length being such that it may fall between the ends and its breadth being equal to the diagonal of the end pieces when in place; therefore it extends from the lower

front edge to the upper rear edge of the frame. Attached to the lower front bar is a broad blade of iron or steel, inclined somewhat downward and forward from the plane of the bottom of the box. The whole is attached to a dredge frame, to which the chain used in dragging is made fast. (See cuts 4 and 5.)

When this appliance is dragged over the bottom the oysters and other inhabitants of the beds, together with shells and debris of all kinds, are lifted from their resting-places by the blade and deposited upon the inclined screen or apron. The motion of the trap and the pressure exerted by the accumulating material in front gradually pass the mass backward across the screen, the smaller particles, drills, etc., sifting into the box, while the oysters, being too large to pass through, finally fall over the edge behind.

By this means the varied material on the beds undergoes a process of screening, the oysters being automatically returned to the bottom, while a large part of the debris is held and brought to the surface. That the device will accomplish this has been demonstrated, but whether the drill can be successfully fought by this means has still to be shown, although the prospects are favorable.

PROTECTION FROM WINKLES.

The conchs or winkles have never been a serious menace to our oyster-beds. Their small numbers and large size and the large size of their egg cases make it possible to successfully fight them by destroying all winkles and egg cases brought up in the process of dredging or tonging.

PROTECTION FROM SPONGES, HYDROIDS, MUSSELS, ETC.

The growth of sponges, hydroids, etc., when so rank as to threaten the welfare of the oysters, may be kept down by working over the beds with the oyster dredge and culling out the debris. A thorough cleaning up of the ground before planting and the use of clean seed and cultch go far toward the prevention of trouble from this source.

PROTECTION FROM STRONG VEGETABLE GROWTHS.

In places where eelgrass (*Zostera*), etc., grow so rapidly as to cause stagnation of the water and suffocation of the oysters some means must be adopted for its removal. Sometimes it may be removed with an ordinary scythe at low water. A grower in New Jersey has invented for this purpose what has been termed an "aquatic mowing machine."

It is described as follows:

Eelgrass grows abundantly in some parts of the Navesink River and, as in other localities where it is found, acquires in due time full possession of the areas where it grows, rendering them useless for oyster-culture. In combating this enemy of the oyster-planting industry, Mr. Charles T. Allen, of the firm of Snyder & Allen, Oceanic, N. J., has achieved a degree of success heretofore unequalled. After expending much fruitless labor in efforts to mow the eelgrass with a scythe, a method which proved impracticable because the water was sometimes too deep and also on

account of the difficulty of cutting grass growing under water, he invented in 1885 and has since used a device which may be termed an aquatic mowing machine. The machine is rigged on a square-ended scow 20 feet long by 8 feet wide. On the forward end of the scow is suspended, by a framework, a double set of knives, each set being similar to those of mowing machines used by agriculturists. The object in having double knives is to enable the machine to cut when moving backward as well as when moving forward, thus avoiding the necessity of having to turn the scow around when the end of the swath is reached. The knife bar is 12 feet long and consequently cuts a swath 12 feet wide. The power of propelling the machine is supplied by a 6-horsepower high-pressure condensing engine, which is located in the middle of the scow. A line 1,000 feet in length is passed with three turns around a winch head and drawn taut by an anchor at each end, placed a short distance beyond the extreme boundaries of the area to be mowed. It is held in position by a fair-leader or chock having a shive on each side similar to the shive of an ordinary tackle block. The shives facilitate the passage of the line through the leader by lessening the friction and correspondingly decrease the wear upon it. The leader or chock is placed on the forward end of the scow, and not only serves to hold the line in position, but also keeps the scow straight in its course.

When the engine is started, the winch-head revolves, and the pressure of the line, encircling it in three turns tightly drawn, forces the scow through the water. The rate of speed at which it can be operated is 1,000 linear feet in 5 minutes, thus enabling it to mow an area of 2,000 square feet or more per minute, or 1 acre in from 20 to 22 minutes, making allowance for time spent in moving anchors or otherwise adjusting the machinery.

When fitted for work, with coal and water, and manned with three men, including an engineer, which is the number requisite to operate the machinery and attend to shifting the anchors, the draft of the scow is about 8 inches of water. When the anchors have once been adjusted, several swaths can be mowed before they require to be shifted over toward the uncut grass, as the line can not easily be drawn so taut—nor does it need to be—as not to allow the scow to be moved (pushed with a pole) sidewise for a short distance. When necessary, the anchors are shifted by the use of a small boat. Thus the scow is guided back and forth across the lot, cutting the grass with equal facility in both the forward and backward movements. When the grass is cut, it floats to the surface of the water and is carried away by the current. The knives are set in motion by a vertical iron shaft which passes through a horizontal cogged wheel. This wheel is geared to a pulley which is run by a belt from the engine. The vertical shaft is so arranged as to slip up or down in order to gauge the machine to any depth of water within the range of its capacity. The extreme depth of water in which mowing can be successfully done, as it is now adjusted, is about 8 feet. It could doubtless be so arranged as to operate in deeper water.

If there are no obstacles in the way, the grass can be cut within 1 inch of the bottom. If there are oysters on the ground, some allowance for that fact has to be made, and while the grass can not be sheared so close to the bottom, it can be mowed sufficiently close to the oysters to answer all practical purposes. The only thing requisite is to mow it short enough to preclude the possibility of any large quantity of sediment settling in it and choking the oysters. This object is easily attained, as grass a few inches long will not injure the oyster crop. It is when its length is measured by feet and it is filled with sediment that it becomes dangerous.

In the locality where this machine is used the water is about 6 feet deep. It has been customary to mow the oyster-beds quite frequently, five or six times, perhaps, during the growing season, from the first of May to the last of October. The result has been that tracts of bottom that would have otherwise been worthless for oyster-growing purposes have been converted into beds as productive as any in the river. The cost of building a similar machine is estimated by Mr. Allen to be from \$450 to \$500.*

* Hall, Ansley, Rept. U. S. Fish Commission 1892, pp. 477 and 478.

INCREASE ON PLANTED BEDS.

The percentage of seed oysters which reach maturity depends upon local and seasonal conditions, upon the care with which the oysters have been planted and worked, the size of the oysters when planted, and the length of time which they have been left to lie. Under the very best conditions there is a considerable mortality among the plants, and while the individual oysters have increased greatly in size the loss from one cause or another is such that there is by no means a corresponding increase in the total quantity as measured in bushels. In some places the planter is satisfied if he can market a bushel for each bushel planted, depending for his profit upon the increased price brought by the larger growth, but the usual average yield in many localities is two or three times this amount, and cases are known where 500 bushels of shells yielded 3,000 bushels of salable oysters.

GROWING OYSTERS IN PONDS.

In Europe pond culture has been commercially successful for many years, and in some countries practically the entire product of oysters has been derived from this source. Small inclosed ponds, *claires*, have been used in France for greening and flavoring the oysters and parks or partially inclosed ponds, admitting the tides, are used for growing the oysters from seed, but all experiments heretofore made with a view of raising the seed in closed ponds have been attended with failure or scanty success.

Over a large area of our oyster-producing territory the difficulty of obtaining seed is usually not a pressing one and an utter failure to secure a set is rarely confronted upon more than occasional years. Under such conditions, in several regions, the practice of sowing shells has grown to great proportions, but with the vast increase in the planted area an increasing difficulty has arisen in preparing the oysters for market. Growth is slower than formerly, and during some seasons the oysters either do not fatten at all or else so slowly that months are wasted before they can be brought into proper condition. It is significant that complaints of this difficulty come from regions which were at one time famous for the fatness and flavor of their product and that the trouble was not manifested until the population of the beds far outgrew that which was found in their natural condition. The causes leading to the difficulty complained of have never been studied, but the explanation will probably be found in the fact that the quantity of oysters in such regions has outgrown the ability of the waters to supply them with food.

As is elsewhere pointed out, the rate of the growth depends primarily upon the relative richness of the food supply, and a quantity which may be sufficient to cause a moderate growth may still be inadequate to produce the degree of fatness upon which the oyster's toothsome-ness so largely depends.

It is manifestly impossible to propose efficient means for increasing the abundance of the food organisms over any very extended area of open waters, where ownership is vested in the many and the conditions are not subject to control. Only in inclosed or semi-inclosed bodies of water could there be any hope of such regulation of temperature, density, and other factors as to conform to the best conditions for the rapid multiplication of such organisms as constitute the preponderance of the oyster's food. If it were possible for the planter to have at his command a body of water extremely rich in food he could, in a short time and at will, fatten oysters which had grown to a marketable size upon other and less favorably situated beds. It is probable that under intelligent direction a comparatively small area could be made to serve as a fattening bed for all of the oysters produced on a great area of ordinary shelled ground, and that the cost of preparing and maintaining the rich food-producing beds would be returned many-fold in the ready sale and high price which the superior product would be able to command. In many places in the United States this plan is followed with success by transplanting the oysters from offshore beds to harbors and coves, but so far as known no practical and conclusive test of culture in artificially prepared ponds has been made, and it is therefore not possible to give full and practical directions concerning the method to be followed in attempting it.

The European methods are generally not economically adapted to use in our waters, but the experience of French culturists has established certain principles which are of general application, and may serve as a guide to those working upon somewhat similar lines here.

There are many localities within the limits of the oyster-producing region of the United States where pond culture for the purpose of growing and fattening oysters would probably prove successful, and salt ponds, connected with tide water by natural or artificial channels, could often be made to return a good dividend to their owners if converted to the uses of oyster-culture. In other cases low and swampy land might be dredged or excavated so as to answer the purpose, and thus be made to return a revenue in perhaps the only possible manner. Such ponds should be well protected by embankments sufficient to prevent the entrance of water except when desired, the supply being regulated by flood-gates which can be opened or closed at will, or the height of the embankments may be so adjusted that the water from the sea will enter during very high tides only, say once or twice a month. When the ponds are large it has been found that the surface aeration is sufficient to supply the oxygen required, but in smaller ponds it is necessary to attain this end by more or less frequent interchanges of water between the pond and the main body of salt water with which it is connected. In the case of practically inclosed ponds it is necessary to provide for the addition of fresh water to make good the loss occasioned by evaporation. If this precaution be neglected the density of the water will rise above the maximum in which the oyster flourishes.

It may be advisable in some places to reduce the density in the ponds below that of the open waters, as it is well known that the more brackish waters are generally most favorable to the rapid multiplication of diatoms and other minute vegetable forms valuable to the oyster-grower. Experiment could be made to demonstrate approximately the best density for the purpose, and where the water supply is under control the pond could be maintained at nearly or quite the degree of salinity required. The ordinary surface drainage into many natural salt ponds is sufficient to reduce the density below the level in the main waters, and by merely regulating the inflow of sea water the grower will probably find that almost any degree of brackishness may be maintained at will. Such ponds will be found to possess all the requirements for the production of food in abundance, the density will be favorable, their shallowness will cause them to warm early in the season, and thus stimulate the growth of microscopic vegetation, and their immunity from the influences of tides will prevent the carrying away of the food which they produce.

There are, of course, many places where the natural conditions for the production of oyster food are all that could be desired, and there pond culture would doubtless be unnecessary, but in other localities, such as are mentioned at the beginning of this section, it seems to offer the most promising field for experiment.

BREEDING OYSTERS IN PONDS.

While in some of our most important planting regions there is rarely any difficulty in obtaining seed oysters, there are places, otherwise admirably adapted to the industry, in which the supply of seed is extremely precarious. The most remarkable fluctuations in the set of spat take place, and often where there is one year an abundance the following season may exhibit a dearth. In certain localities on Long Island a set of spat rarely occurs, and the planters long ago abandoned the attempt to raise seed and now procure it from some other region more favored in that respect. In still other places, as over the larger part of Chesapeake Bay, the seed oysters are obtained mainly from the natural beds, but with the depletion of these there will be an increasing difficulty in obtaining it, and before long it will no doubt be necessary to derive it from some other source. There is an increasing tendency in the region last mentioned to follow more closely the method of sowing shells practiced in Connecticut; in some places the experiment has met with great success so far as the procuring of a set is concerned, but in other localities the results are too uncertain to permit it to be followed with profit.

Where a "strike" occurs each year with tolerable certainty this method is without doubt the best available to our oystermen, but where the spat may fail to set for several years in succession, the expense of putting down the shells without return will soon eat up the profits of

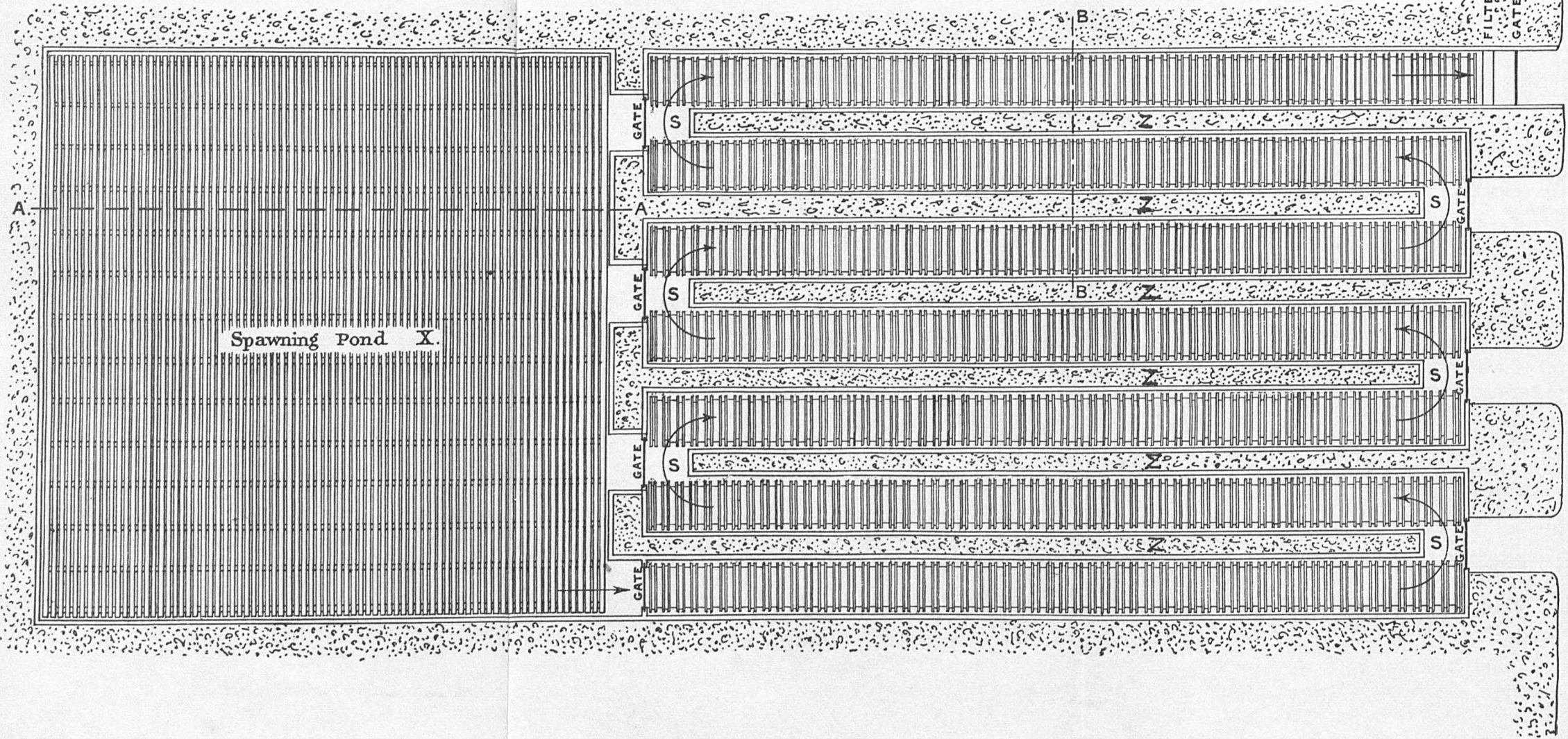
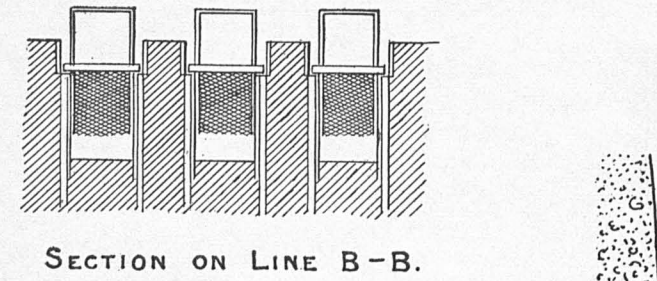
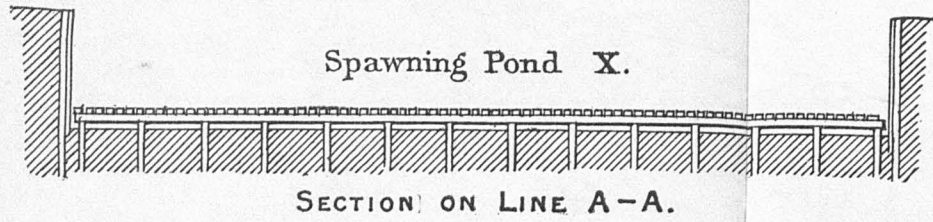

OPEN WATER

GROUND PLAN AND SECTIONS OF PONDS FOR SPAT-CULTURE.

Adapted from John A. Ryder.

more successful years, and the irregularity of his crop may cost the planter his market.

It is obvious that in order to obtain more certain results the conditions upon which the spatting depends should be subject to some control. It is useless to expect such control in any adaptation of the ordinary method of planting shells, and the only direction which promises success in such an attempt is some modification or form of pond culture. The culturists of Europe have shown that a very considerable control can be exercised over the conditions in parks used for growing oysters from seed, and with proper modifications the same success could doubtless be attained with breeding ponds for raising seed. "To actually come into competition with the system of shell sowing in deep water we must proceed to abandon all old methods, condense our cultch so as to have the greatest possible quantity over the smallest possible area, and finally have that so arranged that the currents developed by the tides, in consequence of the peculiar construction of a system of spawning ponds and canals, will keep the cultch washed clean automatically. Unless this can be done, all systems of pond or cove culture for the purpose of obtaining spat must unhesitatingly be pronounced failures."*

Impressed by these facts, Dr. Ryder, in 1885, devised a very ingenious method of spat-culture, which he described as follows:

(A) *The method as adapted to canals or sluices in which the cultch is placed in masses, with jetties at intervals.*

The first form in which I propose to inaugurate the new system of spat-culture which has grown out of the principles already developed consists, essentially, in condensing the cultch or collecting apparatus in such a way as to expose the maximum amount of collecting surface for the spat to adhere to within the least possible area. This may be achieved in the following manner: A pond, X, as shown in plan and elevation in plate III, is constructed with a long zigzag channel, *s*, connecting it with the open water. The pond ought to be, say, 40 to 60 feet square; the channel, *s*, may be, say, 3 feet 3 inches wide, as shown in the diagram. The vertical banks, *z*, between the zigzag canals running to the open water might be 3 feet in width. The sides of the canals ought to be nearly or quite vertical, and the earth held in place with piles and rough slabs or planks. The direct inlet to the pond at *I* might be provided with a gate, and the outlet of the canal, where the latter connects with the open water at *o*, might be provided with a filter of moderately fine galvanized wire netting and a gate; the first answering to keep out large fish and débris and the latter to close under certain circumstances, or when violent storms develop strong breakers. The accompanying plan and sectional elevation, as shown in plate III, will render the construction of such a pond and system of collecting canals clear.

Into the pond, X, I would put an abundance of spawning oysters, say 100 bushels, if the pond were 40 feet square, and 200 bushels if it were 60 feet square. But instead of throwing the oysters directly upon the bottom, I would suggest that a platform, of strong slats be placed over the bottom of the pond at a distance of 8 to 10 inches from the earth below, upon which the oysters should be evenly distributed. This arrangement will prevent the adult oysters from being killed by sediment, and also afford a collector, in the form of a layer of shells, to be spread

* Rept. U. S. F. C. 1885, p. 392.

over the platform, and give the fry a better chance to escape without immediately sinking into the ooze below.

The mean depth of water in the pond and canals ought not to be less than $3\frac{1}{2}$ feet and the bottom of the pond and canals should be cut to the same level, with a view to get the full benefit of the tides.

The method of operating such a system will now be explained. The pond, X, is supplied with the above specified quantity of good spawning oysters, which at a low estimate ought, at the rate of 50 females per bushel, to yield from 100,000,000,000 to 200,000,000,000 of fry during the time the culch may be in position in the canals. If, however, the oysters were very large selected ones, fully twice as much fry ought to be thrown out by them, or fully 200,000,000,000 to 400,000,000,000.

This enormous quantity of embryos must, unless it finds some objects to which to attach itself, be irrevocably lost. In order, therefore, to provide it with a nidus for

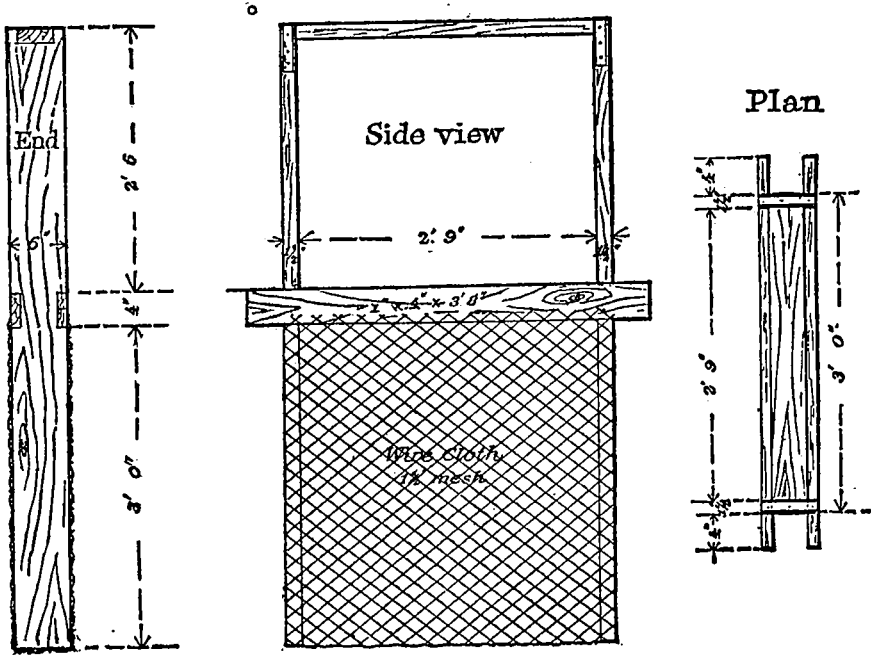

CUT 6.—Receptacle for culch.

the purpose of fixation, an extensive system of collectors is provided in the channel, *s*. These are figured in detail above, the first being an end and the second a side view and the third a plan. These are essentially flat baskets, with wooden ends, and with the bottoms and sides formed of a very coarse kind of galvanized iron wire netting with 1 to $1\frac{1}{2}$ inch mesh. At the top they are open, and on either side a strong strip or scantling is secured and projects out past the ends of the box or receptacle, to afford a means of supporting the whole upon scantling or ledges secured near the tops of the sides of the canals, *s*. These projections of the strips are also intended to afford handles by which two men may lift and move the apparatus about. The uprights at the ends and the horizontal crossbars are intended to enable the culturist to vibrate the box and its contents in the water of the canal without lifting it out, and in such a way as to wash off any injurious accumulation of sediment not swept away by the action of the jetties presently to be described.

These baskets or receptacles are open at the top and are intended to be filled with clean oyster or clam shells as cultch for the spat. They are each to hold about 3 bushels of shells, a quantity as large as can be conveniently handled by two men. One hundred of these will therefore contain 300 bushels of cultch, though I actually believe that 400 such boxes, or 1,200 bushels of cultch, through which sea water charged with fry thrown off by 100 bushels of spawning oysters would pass, would not afford too great an amount of spatting surface, because we have shown on the basis of actual observation that a body of water adapted to oyster-culture is capable of yielding spat throughout all of its three dimensions.

These boxes or frames, after they are filled with the cultch, are suspended in the canals, the cross section of which they should nearly fill at low tide. They are placed with their widest dimension across the canal, so that during the rise and fall of the tide the water has to rush through them no less than four times daily, and as the water is thoroughly charged with embryos, the greatest possible opportunity is afforded the young fry to affix itself.

In order to still further guard against the accumulation of sediment it is proposed to place jetties across the canals. These may consist of boards, forming a frame, which may slide into or be secured by vertical ledges fastened to the sides of the canal. These jetties may have one or two wide vertical slots in them, through which the tide will be compelled to flow with augmented velocity, and thus scour the sediment off of the cultch contained in the suspended boxes or frames on either side of them. Such jetties may be placed at intervals along the canal, and they might be made movable, so as to be changed in order to affect other sets of boxes of cultch at other points along the sluice.

The system of canals, as shown in the plans, should hold about 400 receptacles filled with shells, or at least 1,200 bushels of cultch. In practice I think it probable that even a longer system of canals will be found available; but it must always be borne in mind that the area of the pond must not very greatly exceed the total area of the system of canals, or else so much more water will run out of the pond at every ebb of the tide that a great many embryos will be carried past the system of collectors in the canals into the open water and be entirely lost. There is, consequently, a very good reason for having the areas of the two nearly equal.

The preceding system of culture, it will be obvious, is only an application of principles well established and based upon the observation of the actual behavior of oysters under natural conditions, as observed at Fortress Monroe, St. Jerome Creek, Woods Hole, Cohasset, and Long Island Sound.

The spawning ponds, after the season is over, may be used for fattening choice oysters for market, as they will actually hold about the quantity stated at the outset of this chapter. They may also be used in connection with another modification of the method of using cultch much crowded together or condensed, to be described later on.

The cultch may, without harm to the spat, be allowed to remain in the suspended receptacles in the canals until the first or middle of October, when it should be taken out and spread upon the bottom on the open beds where it is to grow larger. The reason for allowing the cultch to remain so long in the boxes is because spatting under favorable conditions continues for not less than ninety days, or from July 1 to October 1, so that all of this plant should be in working order by the 1st of July.

* * * * *

What we must do to-day is to adapt such means to the solution of the oyster problem as will render them applicable in practice. The American cultivator does not get the price obtained by the French or Dutch oyster-farmer, nor can he for a long time to come expect to, for the reason that the aggregate area upon which the American oyster is cultivated or indigenous exceeds by many times that upon which the European species is either native or cultivated. The European methods of using cultch, such as tiles, slates, brush, fagots, etc., are too expensive, too elaborate, for our practical people. We must reap in quantity what they reap out of the high

price of their product. Under the circumstances there is no possible way of solving the greatest question which now exercises the oyster-growers of this country but to put into their hands a method by the aid of which they can get all the spat they want on their *own* lands and from the spawn of their *own* oysters.

* * * * *

The advantages of the method of using the cultch in concentrated bodies, giving an enormous amount of surface for the spat to adhere to, are that it can be conducted on the land owned by the culturist himself and with the spawn thrown off by the oysters belonging to him. He is, therefore, not bound by any arbitrary oyster laws now existing to conform to what are, generally speaking, very inefficient and often absurd conditions. The new method puts it in the power of the culturist to rear his own seed for planting, and if he is so disposed he may put down an excess of cultch, which he can sell after it is covered with spat to the owners of the open beds in his vicinity. It involves comparatively little outlay to put down a plant which will accommodate 5,000 bushels of cultch, or enough to seed from 20 to 30 acres for the first year. Such a system would be of great practical utility in the region of the Chesapeake Bay, where there are very extensive areas upon which, with very inexpensive excavation, the plant for conducting this method of culture could be organized.

* * * * *

The plan of the small establishment given in the preceding pages is to be regarded as typical. In the use of the system with crowded or condensed cultch in different localities, modifications of the typical plan may often be advantageously employed. For example, an oyster-planter may have a large pond of 2 or 3 acres thickly planted with spawning oysters and connected with the open water by way of a narrow canal. The pond, if it has a firm bottom over its whole extent, may, if not already used for the purpose, be planted throughout with good seed or "plants," which, in the course of two years, will be mostly well-grown, marketable oysters. In such a case, several systems of canals could be fed from the single large inclosure; that is to say, instead of having only a single canal, several zigzag canal systems, each 3 feet in width, might be made to carry the water flowing in and out of the large inclosure, instead of the original channel, which might then be filled up and closed. Or, if it were practicable, the channel connecting the natural pond with the open water might be utilized for the same purpose as artificially constructed canals, provided the cost of modifying it for the purpose were not too great. In some cases, by digging, filling, and dredging, as might be indicated in the course of such a natural channel, it could be prepared for the reception of cultch. Were such a channel wide enough, a system of parallel rows of light piles, the rows being 3 feet 3 inches apart and running lengthwise throughout the course of the channel, might be used to support the receptacles for the cultch, the latter being of the form used in the design of the typical system and supported, as in the latter, upon ledges or scantling spiked horizontally to the rows of piles just below the level of low tide.

In other cases where there existed narrow points in the course of such a canal these might be used as jetties, still further narrowed in some cases, perhaps, by filling in the sides, after which a system of parallel rows of piles with their horizontal supports of scantling might be constructed between the jetties, and upon which the receptacles filled with cultch could be supported. In this way the fry now discharged by spawning oysters from coves through their outlets, sometimes by the thousands of billions annually, can be caught upon cultch and permitted to develop into available spat.

In many cases the cost of digging out the proper channels or canals to be used in the system of applying the cultch in concentrated form would be greatly diminished by the nature of the ground upon which the canals were dug out. If the level of the earth is not much above that of high water, so much the better, for then the

labor to be expended in making the necessary excavations will be proportionally diminished, and no assistance from a skilled engineer will be required.

Whether the spawning pond is excavated or not, the principle upon which the system is constructed and operated remains the same, namely, that the area of the canal systems and the ponds be about the same. In order that the fry be not carried past the collectors, the area of the pond should not much exceed the total area of the canals. In order that the fry may be wafted to the outermost collectors, the area of the canal system ought not to greatly exceed that of the pond or ponds.

Canals constructed between a series of spawning ponds may also be utilized; in fact, a great many other modifications of the system are available, which would become apparent only after a study of a given location. The plans for carrying out this system would, in fact, have to conform to the demands of the location, so that it may be said that each establishment would have to be designed in conformity with local conditions.

* * * * *

If cultch in the form of shells is the best (for which conclusion we have assigned reasons), it follows that such material should be so utilized as to obtain the largest possible return for the least possible outlay. In other words, if shell cultch is to be used at all, let it be expeditiously and economically, and not wastefully and unscientifically, employed. It has been found that even the sowing of shells is profitable, as has been conclusively demonstrated, and in one type of culture, namely, that which is practiced in deep water, it is probable that it is the only practicable method which will be devised for a long time to come. While it is to a great extent wasteful and at times uncertain, for the present, at least, there seems to be no other which can be so economically and successfully operated over large, open, navigable areas. Large areas operated by one individual or corporation can not always be commanded, or only exceptionally, under the existing laws of the States of Maryland and Virginia. In those States, however, where it is possible to command the right to natural areas of water which are more or less nearly land-locked, the system of merely sowing shells would be positively wasteful and not in conformity with the results attainable under the guidance of the proper knowledge.

It is found in the practice of shell sowing that extensive areas will sometimes fail to produce any spat. This is apparently due to the presence of currents which have swept the fry off the beds, or to the presence of sediment, which has put an end to the first stages of its fixed career. Even after the spat is caught, great destruction may occur through the inroads of starfishes, or a too rapid multiplication of worm tubes over the cultch and spat. The latter is sometimes smothered in vast numbers from the last-mentioned cause, as has been recently discovered by Mr. Rowe. Such casualties are rendered either impossible or readily observable during their early stages by the method of inclosing the cultch in suspended receptacles, as suggested in this paper. The netting will effectually protect the young spat against the attacks of large starfishes, and no growth of barnacles or tunicates, worm tubes or sponges, would be rapid enough during the spatting period, judging from an experience extending through several seasons, to seriously impair the spatting capacity of the cultch used in the suspended receptacles. Any of the larger carnivorous mollusks, fishes, or crustaceans which could prey on the young oysters can also be barred out and kept from committing serious depredations by means of the netting around the cultch, as well as by means of screens placed at the mouth of the canal.

The maximum efficiency of the cultch is not realized in any of the old forms of collectors, for the reason that the cultch can not be kept clean; secondly, because both sides of the cultch can not be exposed to the passing fry; thirdly, because the fry can not be compelled to pass over and amongst the cultch repeatedly; fourthly, because the cultch is scattered over too great an area and throughout only two dimensions of a body of water, namely, its horizontal extent, where it is possible, as I have shown above, to do all this and more—that is, to avail ourselves of the possi-

bility of obtaining spat through the three dimensions of a body of water charged with embryo oysters in their veliger condition. These are good and sufficient reasons for my assertion that cultch has hitherto been wastefully and unscientifically applied. With this I must conclude this exposition of the principles of a rational theory of oyster-culture, a subject which has received the attention of many investigators, none of whom have, however, struck at the root of the question and allowed themselves to be guided by readily verifiable facts. In the hope that I have made both the theory and the practice of my new method clear to the reader, who, if he should happen to be an oysterman, will, I hope, at least give me the credit of being honest and sincere in my intentions, and, whether he feels inclined to ridicule or to adopt my conclusions, I feel very certain that what I have formulated in the preceding pages will become the recognized doctrine of the future. *

A trial of this method was made by the Fish Commission at St. Jerome Creek, Maryland, but it was found that Dr. Ryder's expectations regarding the freedom of his apparatus from sedimentation were unfounded. St. Jerome Creek is admirably adapted, from its rich food supply, to growing oysters from seed, but its very advantages in this respect militated against the success of the experiment of spat-raising. A small set was obtained upon some of the cultch exposed, but the deposit of sediment was so rapid that the young oysters were unable to fix in quantities sufficient to make the experiment a commercial success.

It seems probable that under more favorable conditions with respect to sedimentation the apparatus would prove a useful one, and it is to be hoped that it will be given a further trial. The writer witnessed Dr. Ryder's experiment at Sea Isle City, N. J., with a modification of this arrangement, and, although the trial was made on a scale too small, the results were such as to impress him with the feasibility of the device under more favorable conditions than existed at St. Jerome Creek.

One of the principal defects in Dr. Ryder's apparatus appears to be the lack of suitable arrangements for flushing the cultch with currents of water sufficiently strong to scour away any sediment which may accumulate. It was supposed that this could be accomplished by means of jetties, but the current induced in the long canal by the ebb and flow of the tide is apparently too gentle to have the effect sought. This end might be gained by providing the inner loops of the canal with gates communicating with the pond, the outer loops having similar means of communication with the exterior waters, as shown in plate III, which is adapted from Dr. Ryder's plans. If the water in the pond at high tide be held back until the canal has nearly emptied, a strong current could be directed into any loop by opening the appropriate gates. On the other hand, if the gates at the outer end of the loops be closed at low water, a strong current could be thrown into the canals by opening them at high water. By thus occasionally flushing each pair of loops in succession it is believed that the injurious collection of sediment can be prevented in even quite muddy water. The end is accomplished,

* Rept. U. S. F. C. 1885, pp. 381-423, pls. I-IV.

however, by some loss in simplicity of construction and operation of the apparatus and at the expense of the escape of some of the embryos. Plate III shows the original plans modified by the addition of sluice-gates.

It is thought that this method of utilizing cultch may solve the problem of the culture of the eastern oyster upon the Pacific coast. Two chief difficulties there interfere with the obtaining of a strong set: the temperature of the water is in most places too low to insure active spawning, and, secondly, the young of the imported species is crowded out by the rank growth of the native oyster. It is probable that both of these difficulties might be overcome by the use of Dr. Ryder's method or some modification thereof. There is little doubt but that the ebb and flow of the tides through the channels could be so regulated that a sufficient quantity of water would remain at low tide to temper that which would flow in at flood tide. The shallowness of the pond should render it so susceptible to the effect of the sun's rays that a temperature several degrees higher than that of the neighboring water could be maintained, and in some places these two or three degrees are perhaps the measure between success and failure in obtaining a set of spat.

The eastern oyster spawns at 67° or 68° F., but does better at 70°. Ponds such as that described might be located in connection with the sloughs communicating with the bays, and, as Mr. C. H. Townsend says that the native Pacific coast oyster does not flourish in such places, the imported species would doubtless have a better opportunity of survival during its early career, the period when it is especially liable to suffocation by foreign organisms. If necessary, a filter, such as is described on pp. 330-332 of this paper, might be introduced into the mouth of the canal. This would to some extent interfere with the ebb and flow of the tides between the pond and the slough or bay, but it might be the very thing necessary to retard the interchange sufficiently to allow the water in the pond to become warmed by the sun.

The experiment is at least worthy of a trial, and it may be the means of saving to the planters of the Pacific coast the large sums of money which are now annually expended in transporting seed oysters across the continent. The experimenter, if successful, would reap the benefit of his own success. The brood oysters used in stocking the pond should preferably be plants of several years' standing, as such would be more likely to be acclimated than those brought from the East but a short time prior to the experiment.

ARTIFICIAL PROPAGATION.

Artificial propagation in the fish-culturist's sense, the raising of oyster fry from artificially fertilized eggs, has, at the present time, no place in practical oyster-culture. It may perhaps sometime demonstrate its applicability to a system of spat production in small closed ponds, but it can have absolutely no use in the present methods of oyster-growing. It is futile to expect any results from deposits of the swimming fry upon beds planted in the open waters of the bays and sounds where the conditions are usually such as would bring about a wide distribution. Fry so deposited would be, no doubt, largely carried to other beds, and be lost to the man who planted them, or else would fall upon unsuitable bottom. Their fate after being deposited in the water is so uncertain that, in our present state of knowledge, it would be a waste of effort for either Government hatcheries or private individuals to attempt to increase the oyster by such means.

If, however, there can be devised some successful method of closed-pond production, then artificial propagation may find a field of usefulness. Dr. Ryder suggested that the available amount of fry in his method of spat-culture might be increased by adding embryonized water to the inlet to the sluice at the beginning of flood tide, the embryos being carried up through the cultch upon the flood and back again upon the ebb, thus giving a double chance for fixation. There is no doubt but that the proportion of eggs successfully fertilized can be increased by the artificial mixture of the ova and spermatozoa according to methods which science has demonstrated.

Another experiment by the same investigator showed that spat could be raised in a practically closed pond from artificially fertilized eggs. The experiment was briefly as follows: The pond was excavated in the salt marsh on the shore of Chincoteague Bay. It was about 20 feet square and $3\frac{1}{2}$ feet deep, and communicated with the bay by a canal 10 feet long, 2 feet wide, and the same depth as the pond. The mouth of the canal was closed with a filter composed of boards perforated with auger-holes and lined inside with gunny-cloth or bagging. The boards constituted two diaphragms, an inner and outer, the interval of 2 inches between being filled with clean sharp sand. Through this the tide ebbed and flowed, giving a rise and fall of from 4 to 6 inches during the interval between successive tides.

This filter, like most structures of its class, showed a tendency to clog after it had been in use for some time, and as, from its shape, it was difficult to cleanse, Dr. Ryder devised the following arrangement, which is accessible at all times and in which the sand may be renewed at will:

My improved permeable diaphragm is placed horizontally within an oblong trunk or box, A, fig. 1, of plate IV. The box is made of inch planks, to which strong horizontal sidepieces, a, figs. 2 and 3, are secured, and to which are fastened the

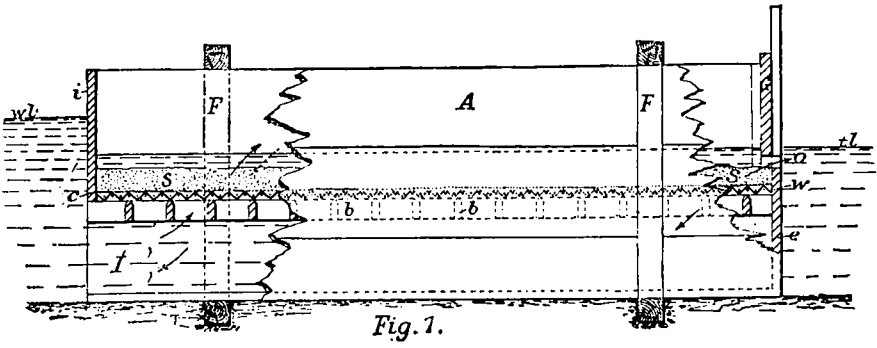

Fig. 1.

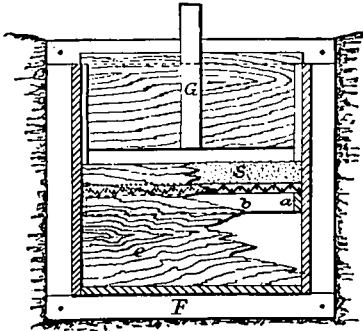

Fig. 2.

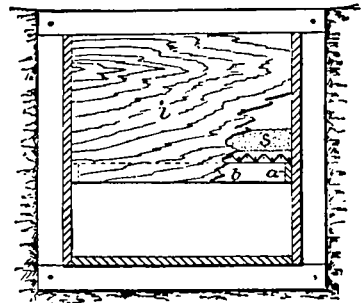

Fig. 3.

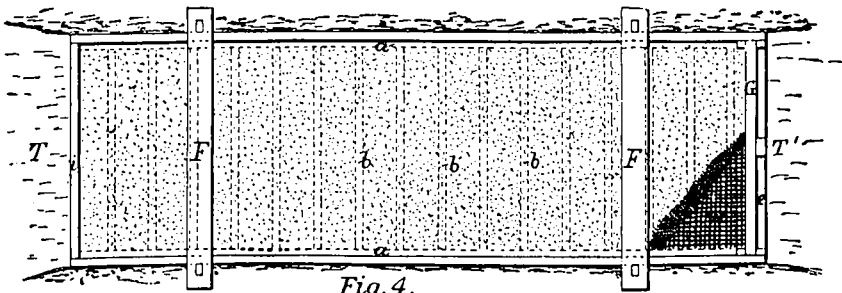

Fig. 4.

DETAILS OF FILTER FOR PONDS USED FOR OYSTER-CULTURE.

After John A. Ryder.

transverse crossbars *b b*, of figs. 1, 2, 3, and 4, upon which the permeable diaphragm rests. Fig. 1 represents the trunk *A* secured within a pair of quadrangular frames, *F F*, and partially in sectional elevation in place in the trench or canal leading from the pond to the open water; fig. 2 represents the construction of the end of the trunk next the open water, and fig. 3 that of the end next the pond, while fig. 4 shows the trunk as viewed from above.

On the crossbars *b b* a single screen of galvanized wire cloth, *W*, fig. 1 (galvanized after it is woven), is superimposed, having meshes, say, one-half inch in diameter; upon the wire screen a layer of gunny-cloth, *C*, figs. 1 and 4, is laid, upon which a layer of fine, clean sand, *S*, is spread evenly from one end of the trunk to the other. The end board *e*, extending halfway up at the outer end of the box, runs up past the level of the wire and cloth to confine the sand at that extremity, as shown in fig. 2, while the sand is confined by the board *i* at the other end of the trunk next the pond, as shown in fig. 3. The wire cloth and bars *b b* constitute the support for the sand as it lies upon the gunny-cloth, which is supported in turn by the wire cloth or screen *W*. This is essentially the construction of the filtering apparatus in which the layer of sand, *S*, is at all times accessible, so that it can be removed if it becomes clogged with ooze carried in by successive tides under the gate *G*, figs. 1, 2, and 4. This layer of sand can also be increased or diminished in thickness so as to strain the inflowing and outflowing water more or less effectually, as may be desired, or in order to more or less effectually prevent the escape of any eggs or embryos of oyster which may be developing within the pond and wafted to and fro by the ebbing and flowing currents which are carried in and out of the pond through the diaphragm by tidal action. The gunny-cloth, *C*, fig. 4, may possibly be replaced by, first, a layer of coarse gravel, then a layer of finer gravel superimposed upon that, which would prevent the fine sand from sifting through the supporting wire screen *W*. Gravel would be more durable than gunny-cloth or sacking, which, like all other textile fabrics, will rot if immersed in salt water for a few weeks. In practice, however, a mode of getting over all such difficulties would soon be devised. A coarse sacking to be used for the purpose might be saturated with a drying oil or with tar diluted with oil of turpentine, which when dry would act as a preservative of the material, but not cause it to become impervious.

* * * * *

When the trunk *A* is put in place (which should be done before the water is let into a freshly excavated pond, and also before the water is let into the trench from the sea end), it should be securely placed in position and the earth tightly rammed in along the sides so as to prevent any sea water from finding its way into the pond, except such as passes through the filtering diaphragm. It is also unnecessary to insist that the trunk be constructed in such a way that it will be practically watertight, and not liable to leak between the planks or at the corners. The wire cloth, sacking, or gravel, and sand having been got into place, and when complete forming a stratum having a total thickness of 5 or 6 inches, the operator is ready to cut away the barrier at the sea end of the trench and let in the water.

If then the trunk *A* has been let down into the trench deep enough the sea level at low tide ought to be somewhat above the upper edge of the board *e*. The water will then, as the tide rises, flow back over the sand as far as the board *i*, and will percolate through the diaphragm into the space *I*, under the latter, and so find its way into the pond. After a day or so the pond will be filled with sea water which has practically been filtered, and filtered more or less effectually in proportion to the thickness of the stratum of sand constituting the diaphragm. After the pond has once been filled with the rise and fall of the tide in the open water the level of the latter and that in the pond will be constantly changing; in other words, when the tide is ebbing the water level in the pond will be higher than that of the water outside, as in fact represented at *wl* and *tl* in fig. 1. Under these circumstances there will be a supply of water flowing out through the under division *I* of the trunk *A*, up through the sand and out over its surface through the outlet *O* under the gate *G*. After the ebb tide is over and flood tide begins these levels will be reversed and *wl*

in the pond will be lower than *it* in the open water, and under those circumstances there will be an inflow of sea water into the pond through the diaphragm instead of an outflow, as is the condition of the water level during ebb tide. Under such conditions there will be four alternating periods during every twenty-four hours of inflow and outflow, lasting, we will say, four hours each, not reckoning the nearly stationary intervals between tides or during slack water. This almost constant partial renewal of the water will unquestionably maintain the water inclosed in the pond or ponds by means of diaphragms in a condition fitted to support oysters colonized therein, provided its density is not too great or too slight, and if there is also some microscopic vegetation present.

It will be readily understood from the preceding description how it is intended that the apparatus is to be operated. The figures also give a very good idea of how the diaphragm and trunk are to be constructed, the first four figures being drawn to a common scale of 1 inch to 3 feet.*

The water in the pond remained at about the same density and temperature as that in the open bay and soon developed a greater abundance of food organisms, both plants and animals. Artificially fertilized ova were placed in the pond at intervals during the spawning season, and forty-six days after the beginning of the experiment young spat from one-fourth to three-fourths of an inch long were found attached to the bunches of shells which had been hung upon stakes to serve as collectors. Great difficulty was experienced from sedimentation. The experiment demonstrated that spat could be raised in ponds from artificially fertilized eggs and that it would grow as rapidly as the spat reared in the open bay. As the conditions are stated by Dr. Ryder, it appears probable that equally good or better results might have been attained with less labor by placing a quantity of spawning oysters in the pond.

Not only would there be a saving of labor in the direct use of the spawning oysters, but there would also be no necessity for the sacrifice of the parents, as must be done under the method of artificial fertilization. The increase in the size of the spawners under the favorable conditions of growth would probably go far toward the payment of expenses.

The method which promises the best results is that in which the eggs are deposited in the pond within from three to five hours after fertilization. There is apparently nothing to be gained in holding the eggs a longer time, the chief gain of the culturist being not in the protection of the embryo, but in the increase of the proportion of eggs fertilized.

The method of fertilization used by Dr. Ryder was as follows:

The method formerly used was to first learn the sex of a number of adult oysters with the microscope, then cut out the generative glands with their products and chop up those of different sexes separately in small dishes with sea water. This system we may now say is barbarous, because it is crude. Large numbers of eggs are destroyed by crushing, or are injured by the rough usage to which they are subjected, and, besides, there is no assurance that the eggs or milt operated with are quite mature. It is also troublesome to free the generative gland from fragments of the liver, which help to pollute the water in the incubating vessels with putrescible

* Bull. U. S. F. C. 1884, pp. 19, 21, 22, 23.

organic matter, and thus interfere greatly with the life and healthy development of the embryos.

By our method the objectionable features of the old plan, as stated above, are overcome. If possible select good-sized oysters; open them with the greatest possible care so as not to mutilate the mantle and soft parts. Carefully insert an oyster knife between the edges of the valves and cut the great adductor muscle as close as possible to the valve which you intend to remove, leaving the animal attached to the other valve, which, if possible, should be the left or deepest one. The soft parts being firmly fixed or held fast by the great adductor muscle to the left valve prevents the animal from slipping under the end of the pipette, held flatwise, as it is gently and firmly stroked over the generative gland and ducts to force out the generative products.

To prepare the animals to take the spawn from them after opening, the following precautions are to be observed: Note that the reproductive gland in great part envelops the visceral mass and extends from the heart space, just in front of the great adductor, to within a half inch or so of the head or mouth end of the animal, which lies next to the hinge. Note also that both sides of the visceral mass which incloses the stomach, liver, and intestine are enveloped on either side by a membrane which also lies just next the shell and is garnished by a fringe of purplish, sensitive tentacles along its entire border except at the head end, where the mantle of the left side passes into and is continuous with that of the right side of the animal. The ventral or lowermost side of the animal, anatomically speaking, is marked by the four closely corrugated gill plates or pouches, which are preceded in front by the four palps or lips, but both the gills and palps depend downward between the lower borders of the mantle of the right and left sides. Note, too, that if the mantle is carefully cut and thrown back on the exposed side of the animal between the upper edges of the gills and the lower edge of the cut or exposed end of the great adductor muscle, the lower and hinder blunted end of the visceral mass will be exposed to view. It is on either side of this blunted end of the visceral mass between the upper edge of the gills and lower side of the great muscle that the reproductive glands open almost exactly below the great adductor. From these openings we will afterwards find, if the animal is sexually mature and the operation is properly conducted, that the spawn will be forced out in a vermicular, creamy white stream. But in order to fully expose the reproductive organ we should carefully continue to sever the mantle of one side with a sharp penknife or small scissors some distance forward of the great muscle toward the head, cutting through the mantle just above the upper borders of the gills and following a cavity which lies between the latter and the lower border of the visceral mass.

A little experience will teach one how far it is necessary to carry this incision of the mantle. For some distance in front of the heart space the mantle is free or detached from the visceral mass and reproductive organ, which lies immediately beneath, and this enables one, if the last-described incision has been properly made, to almost completely expose the one side of the visceral mass and the richly tinted, yellowish-white reproductive gland which constitutes its superficial portion. The opening of the gland and its superficial ramifying ducts being laid bare on the exposed side of the animal, we are ready to press out the spawn on that side. Before beginning this, however, it is important to observe that the principal duct passes down just along the edge of the visceral mass where the latter bounds the heart space, in which the heart may be observed to slowly pulsate, and that this great duct ends somewhere on the surface of the ventral blunted end of the visceral mass (plate 1, fig. 2 *d*). To expose the great or main generative duct it may be necessary to cut through or remove the pericardial membrane which incloses or covers the heart space on the exposed side. If the oyster is sexually mature, the main duct will be observed to be distended with spawn, and that, originating from it and branching out over almost the entire surface of the visceral mass, there are minor ducts given off, which

again and again subdivide. If these are noted and it is observed that they are engorged, giving them the appearance of a simple series of much-branched great veins filled with creamy white contents, it may be certainly presumed that your specimen is mature and that spawn may be readily pressed from it.

The operation of pressing the spawn out of the ducts requires care. The side of the end of the pipette may be used, being careful not to crush or break open the ducts as you gently and firmly stroke the pipette flatwise over the side of the visceral mass backward from the hinge toward the heart space and over the great duct at the border of the latter diagonally downward and backward to the opening of the reproductive organ. If this has been properly done it will be found that the generative products are being pushed forward by the pipette through the ducts, as the pressure will be seen to distend the latter, the contents of the branches flowing into the larger and larger trunks until they are forced outward through the main duct and opening below the great adductor, where they will pour out in a stream one-sixteenth of an inch or more in diameter if the products are perfectly ripe. The sexes may be discriminated as described at the outset, and it is well to first find a male by the method already given and proceed to express the milt as described above into, say, a gill of sea water, adding pipetteful after pipetteful until it acquires a milky or opalescent white color. As the milt or eggs are pressed out of the opening of the ducts, they are to be sucked up by the pipette and dropped into the water, the mixture of milt being first prepared, to which the eggs may be added as they are expressed from the females. The judgment of the operator is to be used in mixing the liquids; in practice I find that one male will supply enough milt to fertilize the eggs obtained from three or four females, and it does not matter if the operation takes from twenty to thirty minutes' time, as the male fluid, which it is best to prepare first, will retain its vitality for that period.

It is always desirable to be as careful as possible not to get fragments of other tissues mixed with the eggs and milt, and the admixture of dirt of any kind is to be avoided. To separate any such fragments nicely, I find a small strainer of coarse bolting or cheese cloth to be very convenient.

In the foregoing description we have described the method of obtaining the spawn only from the side of the animal exposed in opening the shell. A little experience will enable one to lift up the head end of the animal and throw it back over the great adductor muscle, expose the opening of the reproductive organ on the left side, or whatever the case may be, and also express the spawn from that side, thus as effectually obtaining all of the ripe eggs or milt as is possible in the process of taking the same from fishes.

It is remarkable to note the success attending this method, since almost every egg is perfect and uninjured, the percentage of ova, which are impregnated, is much larger than by the old method, reaching, I should say, quite 90 per cent of all that are taken when the products are perfectly ripe. It is also found that the products are not so readily removed by my process if they are not perfectly mature, which is also to a certain extent a safeguard against poor or immature spawn. In the course of an hour after the products of the two sexes have been mingled together it will be found that nearly every egg has assumed a globular form, has extruded a polar cell, lost the distinct germinative vesicle and spot in the center, and begun to develop.

It is noteworthy that our practice as herein described has completely vindicated the statement made by the distinguished French anatomist and embryologist, M. Lacaze-Duthiers, that there is but a single generative opening on each side of the visceral mass of the oyster, and that, as we have stated, it is found to open just below the great adductor muscle.

We have also discovered, since the foregoing was written, that the use of an excessive amount of milt is of no advantage. The water in which the eggs are to be impregnated only requires to be rendered slightly milky; a very few drops of good milt is sufficient to make the impregnation a success. Too much milt causes the eggs

to be covered by too large a number of spermatozoa; thousands more than are required if too much is used. These superfluous spermatozoa simply become the cause of a putrescent action, which is injurious to the healthy development of the eggs. A drop of milt to 20 drops of eggs is quite sufficient.

Immediately after the ova have been fertilized it is best to put them into clean sea water at once, using water of the same density as that in which the adults grew. If the attempt is made to impregnate the eggs in water much denser than that in which the adults lived, it is probable that the milt will be killed at once. This singular fact, which was accidentally discovered by Colonel McDonald and myself, shows how very careful we should be to take into consideration every variation in the conditions affecting a biological experiment. If sufficient water is used no trouble will be experienced from the pollution of the water by dangerous micro-organisms, which are able to destroy the oyster embryos. From 50 to 200 volumes of fresh, clean water may be added to the volume in which the eggs were first fertilized. This may be added gradually during the first twenty-four hours, so as to assist aeration and prevent the suffocation of the embryos. *

ARTIFICIAL FEEDING.

There is no practical way now known of furnishing oysters with an artificial food supply.

Experiments have been made with a view to feeding the adult oysters upon corn-meal or some similar substance, but such attempts have been of no practical value. There is no doubt that they would eat corn-meal or any other substance in a sufficiently fine state of division to be acted upon by the cilia. The oyster is incapable of making a selection of its food, and probably any substance, nutritious, inert, or injurious, would be swept into the mouth with complete indifference except as to the result. Corn-meal and similar substances would doubtless be nutritious, but their use must be so wasteful that the value of the meal would be greater than that of the oyster produced.

The only way in which the amount of oyster food can be increased is by so regulating the conditions in ponds or parks that the natural food may grow in greater luxuriance. In artificial propagation the life of the young has been prolonged beyond the early embryonic stages by feeding upon certain marine algæ reduced to a powder by pounding them in a mortar, but such successes have been purely experimental and are of no significance from a practical standpoint. Even if artificial propagation were to obtain a place in practical oyster-culture, the fry would doubtless be liberated before resort to artificial feeding would become necessary.

* Fisheries Industries, Sec. I, pp. 723, 724, 725.

FATTENING, PLUMPING, FLOATING.

As has been frequently pointed out, the so-called "fattening" of oysters for a short time previous to sending them to market is not a fattening process at all, but is a device of the trade to give to the oysters an illusive appearance of plumpness. It adds nothing whatever to the nutritive qualities of the oyster, but on the contrary injures its flavor and extracts certain of its nutritious ingredients. However, as long as the public desire such oysters the dealers can not be blamed for supplying them.

The process of plumping consists in changing oysters from denser to less dense water, causing an interchange of fluids through the walls of the animal, the denser fluids in the tissues passing slowly outward, the less saline water in which the animal is immersed passing more rapidly inward. The net result is to cause a swelling of the tissues by an increase in the fluid contents, in much the same manner as a dry sponge swells when moistened. The oysters are not usually placed in absolutely fresh water, which would kill them if exposed too long, but in fresher than that in which they have been living. The fluids which have passed out from the tissues carry with them salts and some fats, chemical experiment showing that the oyster, although larger after plumping, has lost 13 per cent of its original nutritious substances, protein, fats, carbohydrates, and mineral salts. Sufficient water will be taken up, however, to increase the total weight of the oyster from 12 to 20 per cent. The same result is produced by placing the oysters in fresh water after they have been removed from the shell. It will be seen that what the oysters have gained is simply water, of no value as food.

If the living oysters are left too long on the floats they will again become "lean," leaner than before, in fact, owing to the state of equilibrium which is finally established between the density of the juices within the tissues and without. If oysters are taken from brackish water to that which is considerably more saline they become shrunken, tough, and leathery, owing to the converse process to that of plumping.

Various forms of floats are used. One of the simplest consists of trays 8 feet by 16 feet by 2 feet deep, with perforated bottoms, these being raised from the water for filling and emptying by means of a chain attached to each corner and a pair of windlasses supported upon piles.

While not harmful in itself it may be well in this connection to sound a word of warning. Oysters may, and no doubt sometimes do, consume pathogenic bacteria, or disease germs, with their food; and such germs, transferred to the human economy with vitality unimpaired may upon occasions have serious results. Care should be exercised to construct the floats in such places as are free from the contaminating influences of sewer discharge and other sources of pollution.

In France the oysters are subjected to a true fattening process in inclosed ponds or claires, their flavor and appearance being much improved thereby.

GREENING.

Notwithstanding that almost every recent writer upon the subject has insisted upon the harmlessness of the green coloration which is frequently observed in certain portions of the oysters, there is still considerable misapprehension of the subject by consumers and oystermen alike. The prejudice is confined to America, in Europe such oysters being regarded as superior, and much trouble being taken to impart to them their peculiar viridity. In our waters the greening is liable to occur in certain localities and at irregular times. Rather shallow waters appear to be more susceptible to the production of this effect than the greater depths, but it has recently appeared on the deep-water beds of Long Island Sound.

When oysters become so colored the oystermen find great difficulty in disposing of them, owing to the popular belief that they are unfit for food, or even poisonous. They often have what is described as a coppery taste, and uninformed persons usually assume that the green color is due to the presence of copper. A number of careful investigations have shown that such oysters contain no copper whatever, but that the green color is derived from a harmless blue green substance, phyco-cyanin, which is found in certain of the lower plants.

Under proper conditions these unicellular vegetable organisms multiply in brackish or saline water with great rapidity and provide an important item of food to the oyster. The green matter is soluble in the juices of the oyster and passes into the tissues, affecting principally the blood corpuscles.

An oyster usually shows the first indication of greening in the gills and palps, and frequently this is the only portion of the animal which is colored, a fact which is explained when we remember that this is the most highly vascular portion. When the supply of greening food is abundant and long continued, the mantle, liver, and eventually the entire organism, with the exception of the muscle, acquire a green hue. Such oysters are usually, but not always, fat and well fed, the result of the abundant supply of nutritious food, and such a condition could hardly obtain were the dye a copper product, such as has been popularly supposed.

The color may be removed from the oysters by transferring them for a short time to waters in which the green food is deficient, a fact which may be available in preparing for market oysters which popular prejudice refuses to use in the green state.

In conclusion, it may be again insisted that the greening is not a disease, nor a parasite, nor a poisonous material in any sense.

**TRANSPORTATION AND LENGTH OF LIFE WHEN REMOVED
FROM THE WATER.**

Under proper conditions the oyster will live for a long time after its removal from the water. Professor Verrill records a case in which marketable oysters survived for over ten weeks while hung up in the window of a shop, during the months of December, January, and February. The temperature was variable, but upon the whole rather cool. He says:

The remarkable duration of the life of these oysters is undoubtedly due to two causes:

1. The perfect condition of the edges of the shells, which allowed them to close up very tightly.

2. The position, suspended as they were with the front edge downward, is the most favorable position possible for the retention of water within the gill cavity, for in this position the edges of the mantle would closely pack against the inner edges of the shell, effectually closing any small leaks, and the retained water would also be in the most favorable position to moisten the gills, even after part had evaporated. It is also possible that when in this position the oyster instinctively keeps the shell tightly closed, to prevent the loss of water.

This incident may give a hint as to the best mode of transporting oysters and clams long distances. Perfect shells should be selected, and they should be packed with the front edge downward and kept moderately cool in a crate or some such receptacle which will allow a free circulation of air. Under such favorable conditions selected oysters can doubtless be kept from eight to twelve weeks out of water.

So far as is known, Professor Verrill's suggestion has not been followed by shippers, who seem to have no difficulty in making shipments to distant points.

Oysters are usually transported in barrels or sacks. To far inland or transcontinental points shipment is made in refrigerator cars. In the transportation of American oysters to Europe the same method of packing is followed, and they are carried in the cold-storage chambers of the vessels.

Several devices for locking the oysters, so as to prevent the gaping of the valves and the escape of the fluids, have been patented, but they do not appear to be in extensive use at the present time.

It is stated by some dealers that oysters which have been "plumped" or "fattened" stand shipment better than those which have not been subjected to the process.

The oyster, of course, can not feed during the period of its deprivation from water, and to maintain its vitality it makes draft upon its own tissues and gradually becomes poorer in quality. As the vital activities are apparently reduced at such times, the waste of tissue is small.

NOTES ON CLAM-CULTURE.

Owing to the importance of several species of clams as food for man and as bait in the line fisheries, it is deemed desirable to append a few facts relating to them and to their culture.

Two species are in common use upon the Atlantic coast, one of them also being an introduced species upon the Pacific coast. The quahog, hard clam or round clam (*Mercenaria mercenaria*), is perhaps the more important. It is the "clam" of the markets of New York, Philadelphia, and southward, and it is also utilized to some extent in New England. It is a heavy-shelled form living on the muddy bottoms, principally below low-water mark, where it is taken by means of rakes or by the process of "treading out," the clammer wading about and feeling for the clams with his toes and then picking them up by hand or with a short rake.

The long clam or *mananose* (*Mya arenaria*) is the principal species in the markets north of New York, and, on account of the comparative lightness of its shell, is often called the "soft" clam. This species was introduced on the Pacific coast with oysters brought from the East, and has now become widely distributed there and an important food product. It is found principally on sandy shores or in a mixture of sand and mud, between tide marks. Its long siphons permit it to burrow to a considerable depth, and it is dug from its burrows by means of spades, stout forks, or heavy hoes or rakes.

The soft clam appears to be the only species which has been the object of attempted cultivation, although no doubt the quahog is equally favorable for the experiment.

In Chesapeake Bay the soft-shell clam spawns from about September 10 to October 20. The eggs are of about the same size as those of the oyster, and in their early development pass through practically the same stages. At the end of the free-swimming stage the clam is still very small. It settles to the bottom, but instead of becoming attached to shells or other firm bodies in the water it soon burrows into the bottom until it is completely hidden with the exception of the tips of the siphons, through which it derives its supply of food and oxygen from the currents of water induced by the action of cells provided with hair-like processes (cilia). Upon very soft bottom the young clam, like the young oyster, is liable to become suffocated in the mud, but as it grows

larger its powers of locomotion, which, though limited in degree, persist throughout life, enable it to extricate itself.

Owing to its free-living habit, the methods in use for catching oyster spat can not be utilized for the growing of seed clams. Although so far as known no successful attempt has been made to obtain clam spat, it seems probable that a moderately soft bottom naturally devoid of clams could be made available by covering it with a coating of sand of sufficient depth to prevent the sinking of the young during the early stages after it falls to the bottom. Later in life they are better able to care for themselves.

In certain places the planting of seed clams has been attended with some success, as is shown in the following account:

Quite an interesting feature in connection with the clam fisheries at Essex, Mass., was found in the shape of clam-culture. In 1888 an act was passed by the legislature authorizing the selectmen of the town to stake off in lots of 1 acre or less each of the flats along the Essex River, and let them to persons desiring to plant clams for a rental of \$2 per acre or lot for five years and an additional fee of 50 cents. Thus far 37½ acres have been taken up and seeded with clams. Small clams are dug on the natural beds and planted on these hitherto unproductive flats. About 500 bushels are required to plant an acre properly. During the first two years (1889 and 1890) the people were slow to avail themselves of the privilege of planting for fear that after they had spent their time and labor they would not be able to secure protection from trespassers. But in 1891 and 1892 lots were obtained and planted. The principal difficulty encountered has been the loss of the clams by the sand washing over them, the bottom in some localities being soft and shifting. In 1892 there were 25 acres that were quite productive, about one-third of the entire catch of the section being obtained from them. The catch from these lots is not definitely known, but is estimated at about 2,500 barrels.

The cultivated clams possess some advantage over the natural growth from the fact that they are more uniform in size and are as large as the best of the natural clams. They bring \$1.75 per barrel, while the natural clams sell for \$1.50 per barrel. This is the price received by the catchers. One acre of these clams is considered to be worth \$1,000 if well seeded and favorably located so as not to be in danger of being submerged with sand. This valuation would be too high for an average, since all the acres are not equally well seeded and located. The clambers are generally impressed that the industry can be extensively and profitably developed, and their only fear is that they will not be able to secure lots permanently. The greater part of the land available for this purpose is covered by the deeds of people owning farms along the river, and the consent of the land-owners has to be obtained before lots can be taken up. It seems probable, however, that the business will continue to progress unless checked by complications that may arise relative to the occupancy of the grounds.—Report U. S. Fish Commission, 1894, pp. 139, 140.

It was hoped that these planted clams would propagate on the new beds, but the expectation has not been realized, owing, no doubt, to the unsuitableness of the bottom, a fact which would also account for the absence of the species in the first place.

The growth of the soft clam is quite rapid, and Dr. Ryder has shown that at St. Jerome Creek, Maryland, the shells reach a length of between 1¼ and 1½ inches within several months of the time of spawning.

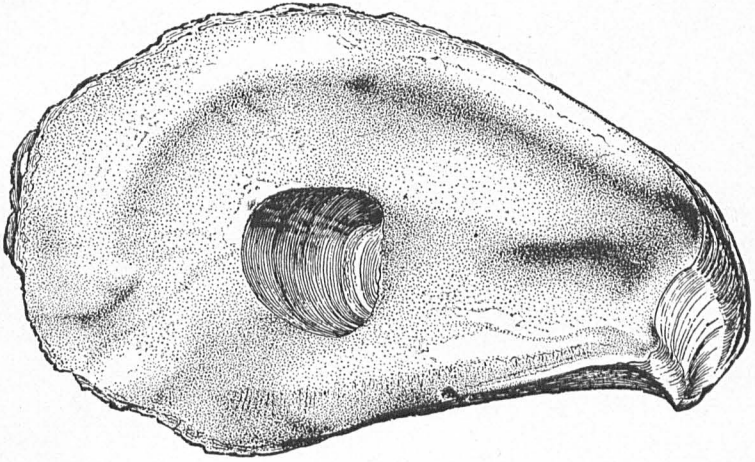

1

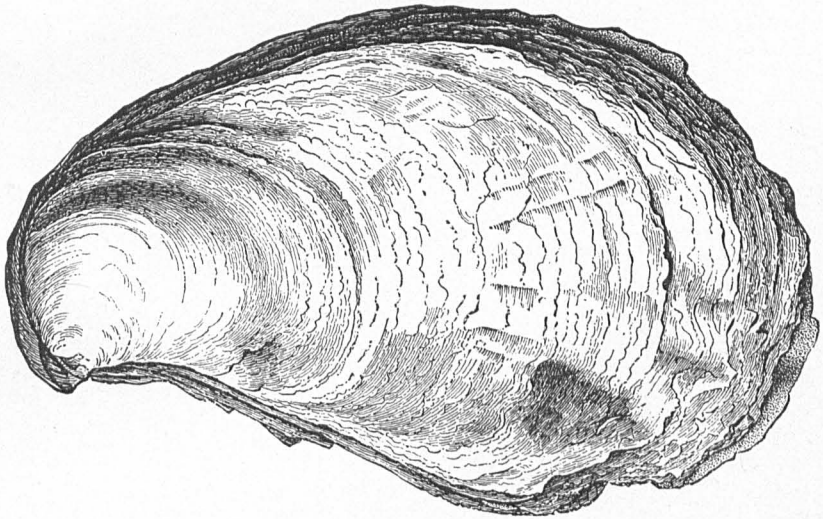

2

FIG. 1, INNER FACE, AND FIG. 2, OUTER FACE OF SHELL OF TYPICAL AMERICAN OYSTER.

From Fourth Annual Report, U. S. Geological Survey.

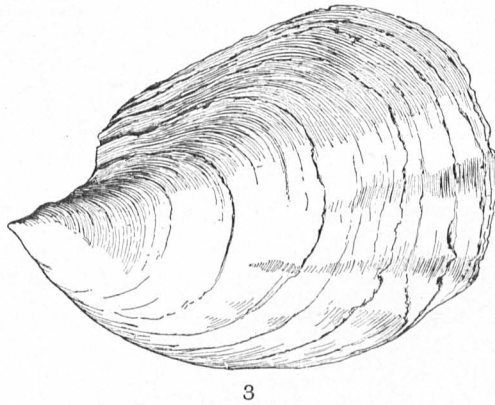
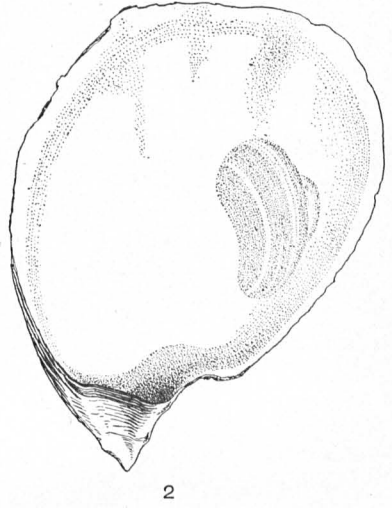
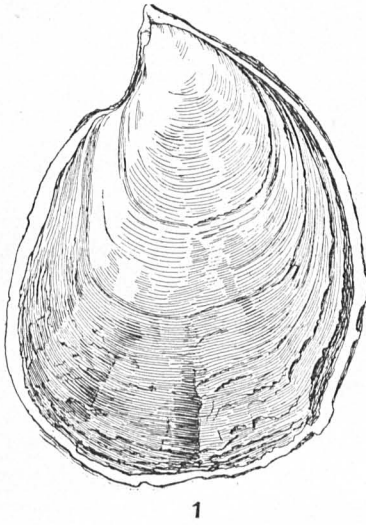

FIG. 1. Upper view of closed valves of Pacific oyster, *Ostrea lurida*.
FIG. 2. Inner face of ventral valve of same specimen.
FIG. 3. Outer face of ventral valve of same specimen.

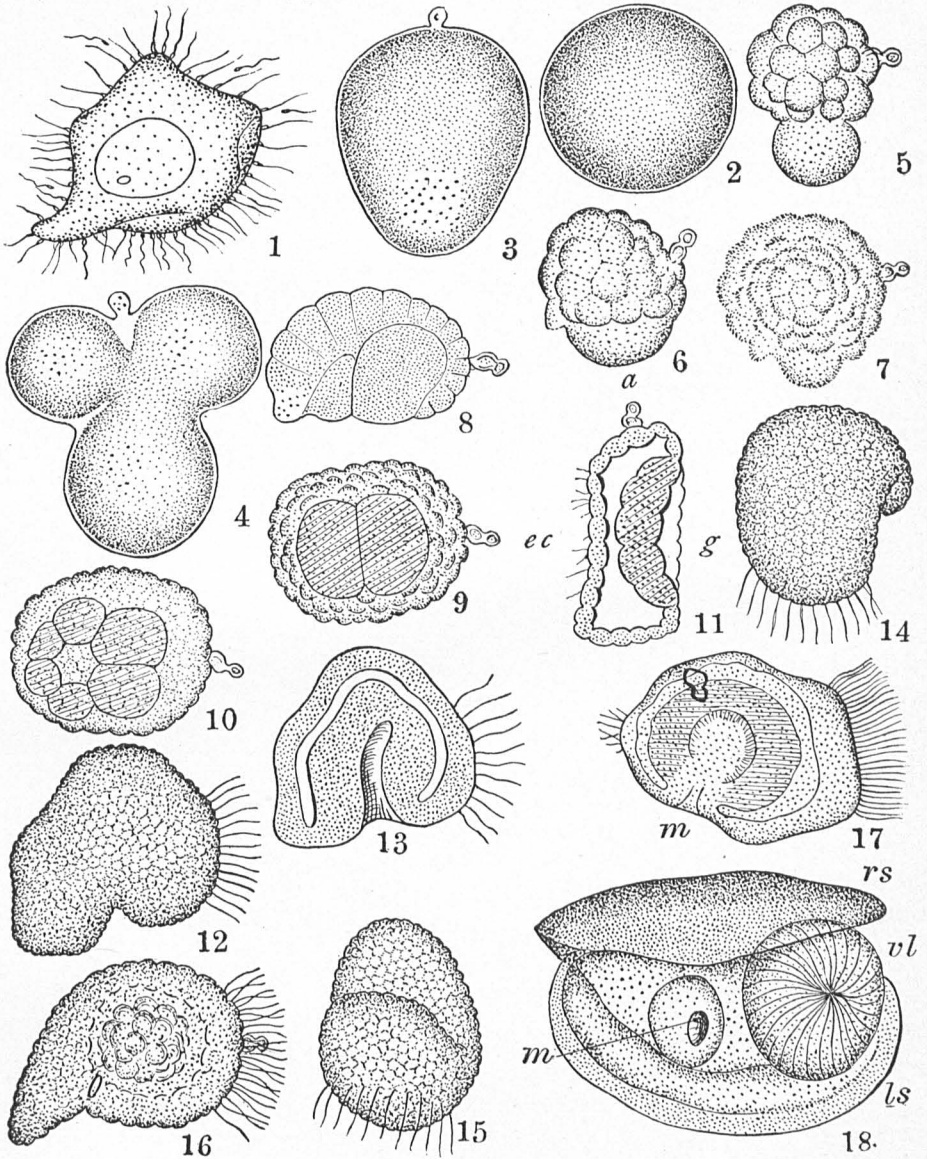

FIG. 1. Unfertilized egg shortly after mixture of spawn and milt; spermatozoa are adhering to the surface.
 FIG. 2. Egg after fertilization.
 FIG. 3. Same egg 2 minutes later. Polar body at broad end.
 FIG. 4. Same egg 6 minutes later.
 FIG. 5. About 6 1/2 hours later.
 FIG. 6. Another egg at about the same stage. Mass of small cells growing over large cell or macromere *a*.
 FIG. 7. Egg 55 minutes later. Macromere almost covered by small cells of ectoderm.

FIG. 8. Optical section of egg 27 hours after impregnation, showing two large cells, derived from *a* in fig 6, covered by a layer of small ectodermal cells.
 FIG. 9. Egg a few hours older, showing large cells viewed from below.
 FIG. 10. An egg somewhat older, showing further subdivision of large cells as seen through cells of upper layer.
 FIG. 11. An older egg, now become flattened from above downward. Viewed in optical section.
 FIG. 12. Surface view of an embryo just beginning to swim.

FIG. 13. Optical section of same.
 FIG. 14. Surface view of same from another position.
 FIG. 15. Surface view of same from another position.
 FIG. 16. An older embryo in same position as in fig 12.
 FIG. 17. A still older embryo showing spherical ciliated digestive cavity opening by mouth, *m*.
 FIG. 18. An embryo with well-developed larval shells, older than fig. 1, Plate VIII. *rs*, right shell; *ls*, left shell; *vl*, velum; *m*, mouth.

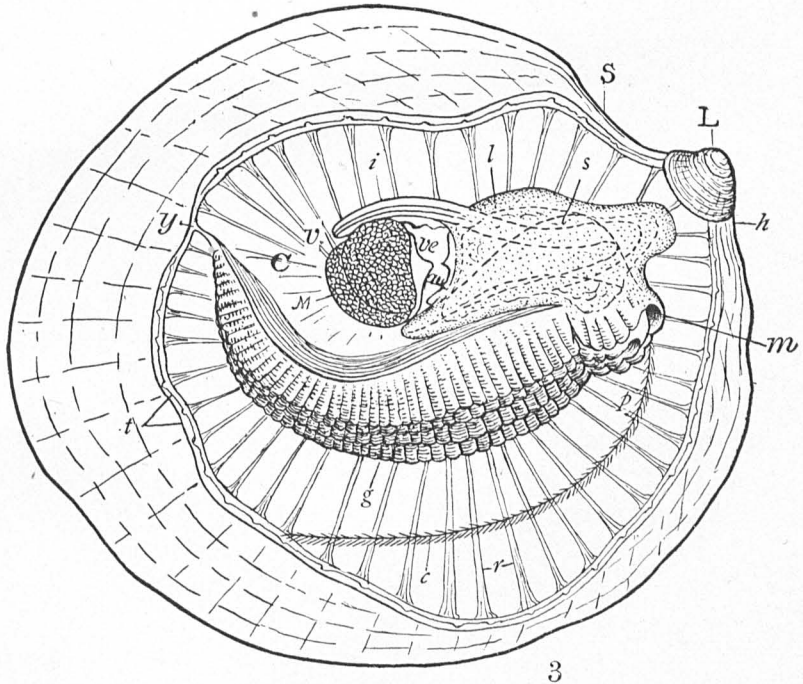
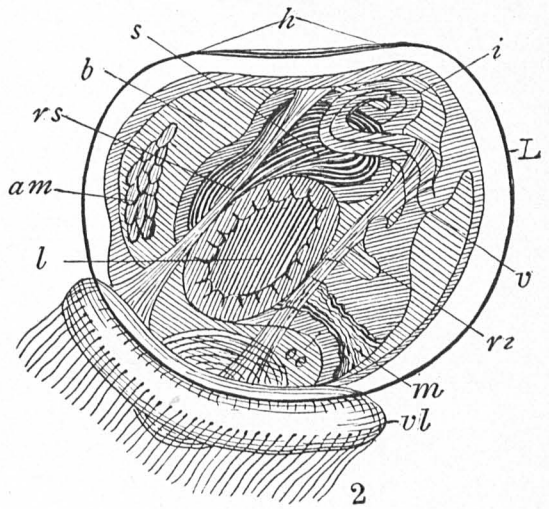
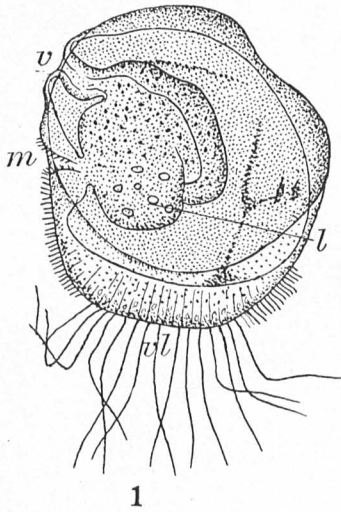
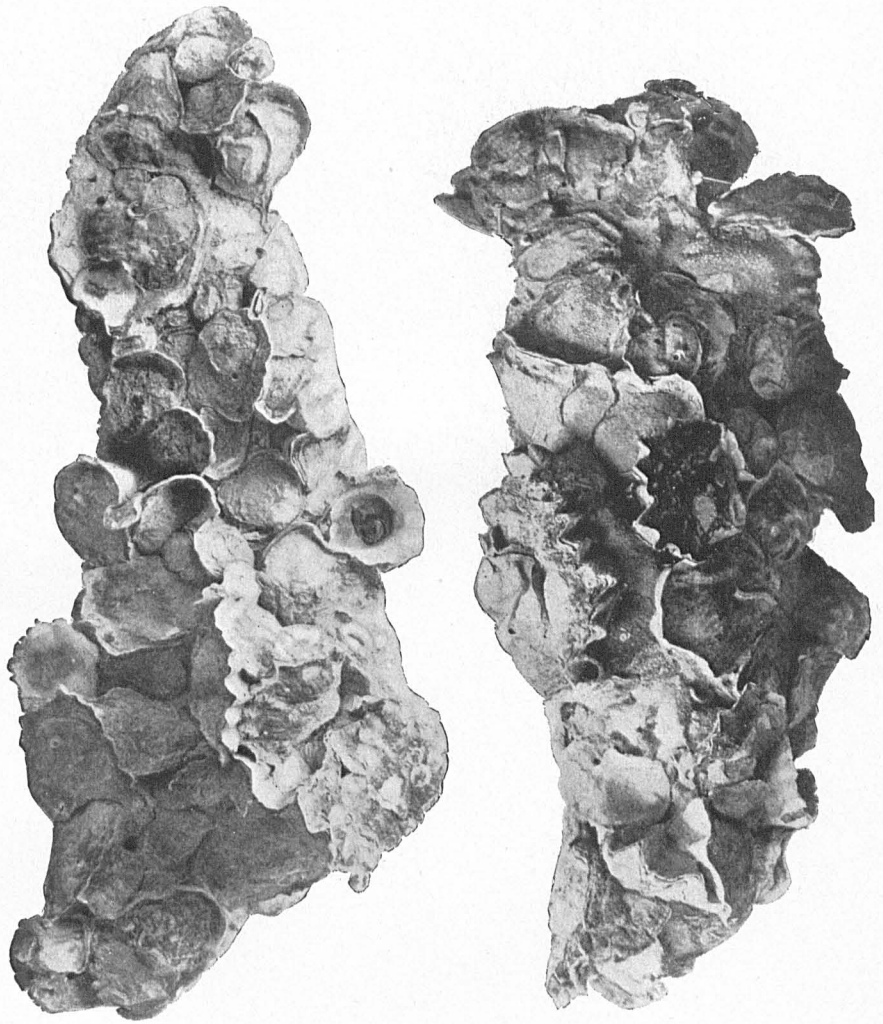
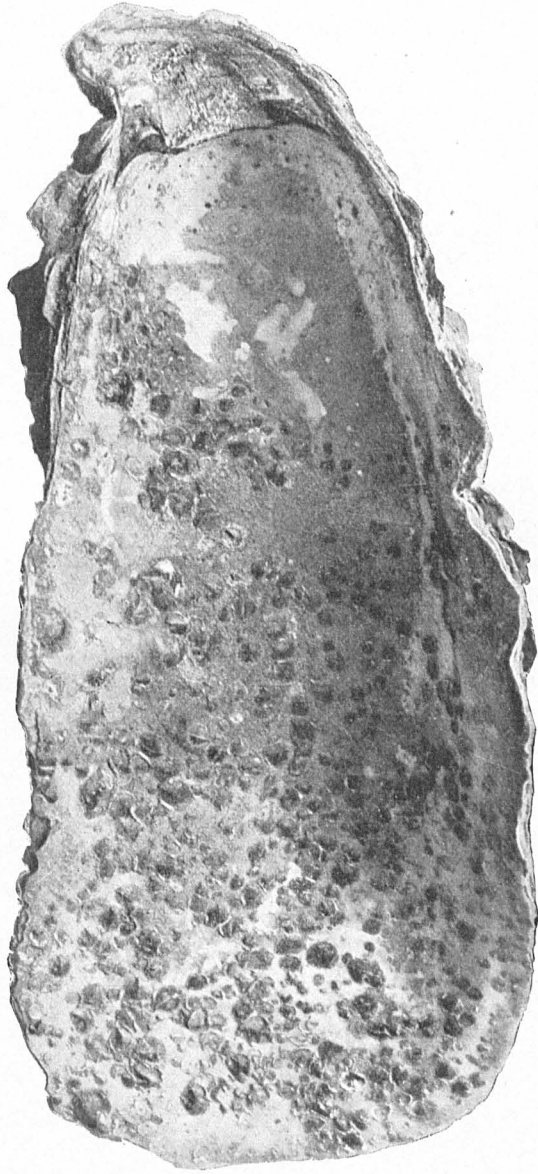

FIG. 1. View of right side of embryo about 6 days old. *m*, mouth; *v*, vent; *l*, right lobe of liver; *vl*, velum.
 FIG. 2. Older larva of European oyster, *Ostrea lurida*. *L*, shell; *h*, hinge; *rs* and *ri*, retractor muscles of the velum. *vl*; *s*, stomach; *i*, intestine; *am*, larval adductor muscle; *b*, body cavity. Other letters as in the preceding.
 FIG. 3. Attached spat of *Ostrea virginiana*. *S*, shell of spat with larval shell, *L*, at the beak or umbo; *p*, palps; *g*, gills; *c*, diagrammatic representation of a single row of cilia extending from the mantle border to the mouth *m*; *r*, radiating muscle fibres of mantle; *t*, rudimentary tentacles of mantle border; *M*, permanent adductor muscle; *C*, cloaca; *ve* and *au*, ventricle and auricle of the heart; *y*, posterior extremity of the gills and junction of the mantle folds. Other figures as above. Compare this figure with Pl. I, fig. 1.

Fig. 1 after W. K. Brooks. Fig. 2 after Thomas H. Huxley. Fig. 3 after John A. Ryder.



SET OF OYSTERS ON RACCOON OYSTER SHELL, SHOWING CROWDING. NATURAL SIZE.



OYSTER SPAT TWO OR THREE WEEKS OLD ON INSIDE OF OYSTER SHELL.
NATURAL SIZE.



OYSTER SPAT ABOUT TWO MONTHS OLD, ON A STONE. NATURAL SIZE.

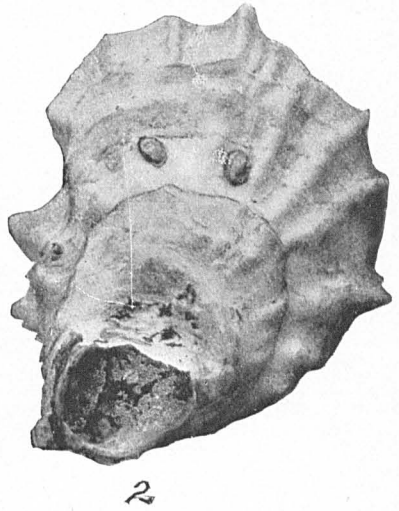
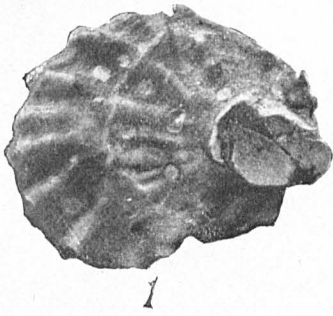

FIGS. 1, 2, AND 3, OYSTERS ONE, TWO, AND THREE YEARS OLD, RESPECTIVELY. NATURAL SIZE.
Grown on hard bottom in Long Island Sound.

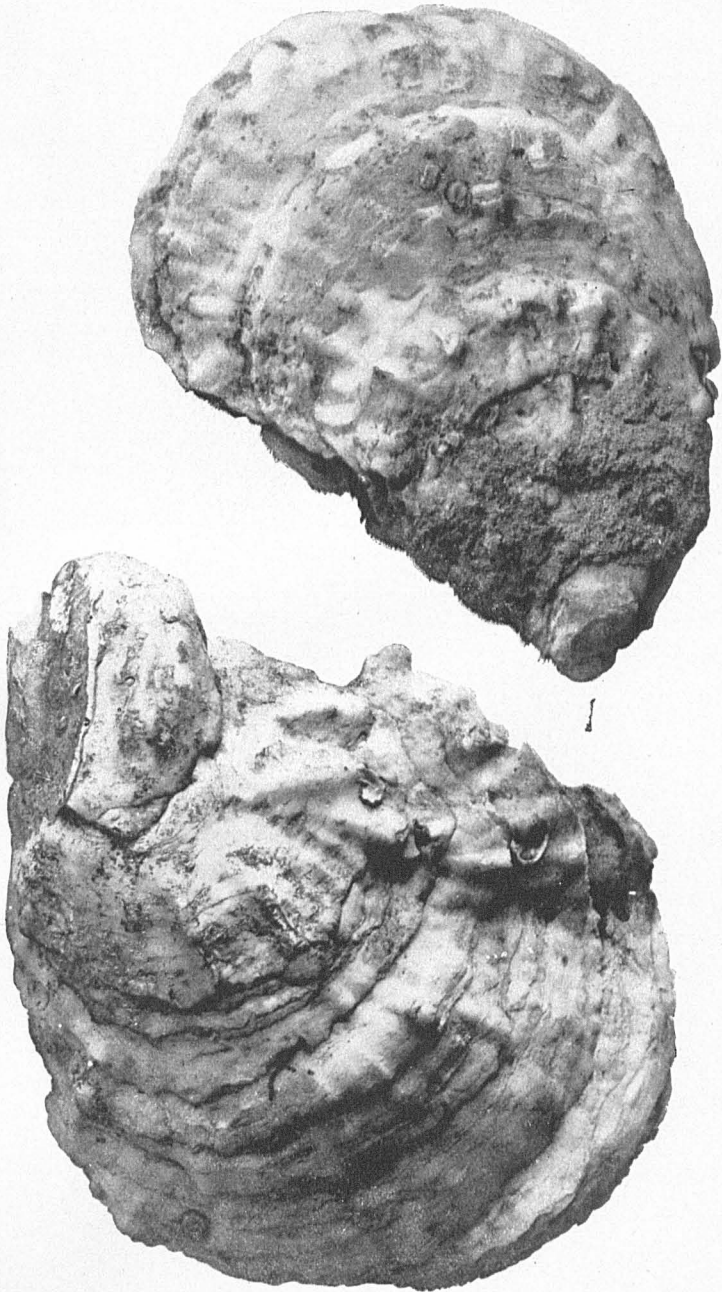

2

FIGS. 1 AND 2, OYSTERS FOUR AND FIVE YEARS OLD, RESPECTIVELY. NATURAL SIZE.
Grown on hard bottom in Long Island Sound.

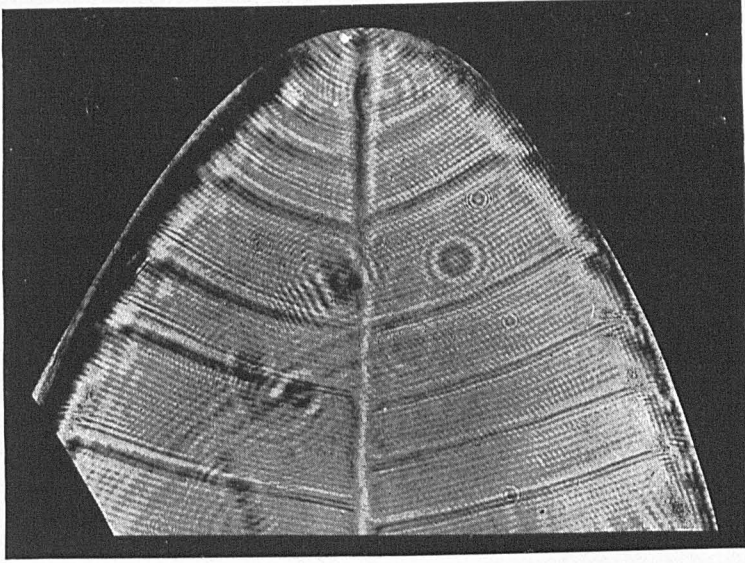

Fig. 1. PHOTO-MICROGRAPH OF THE DIATOM, *SURIRELLA GEMMA*, ENLARGED ABOUT 1,600 DIAMETERS.

The tip of the frustule is alone given, to indicate the character and texture of the glassy surface.

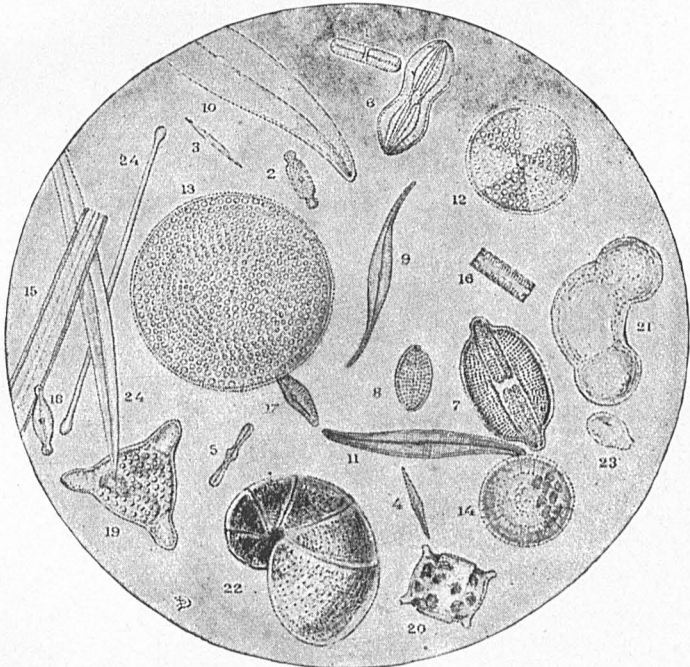

Fig. 2. FOOD OF SOUTH CAROLINA OYSTER. A FEW TYPICAL ORGANISMS ($\times 225$).
Numbers 1 to 20 are diatoms.

- | | | |
|---|--|---|
| 1-5. <i>Navicula</i> (Bory). | 13. <i>Coscinodiscus radiatus</i> (E.). | 20. <i>Biddulphia</i> sp. (Gr.). |
| 6. <i>N. didyma</i> (K.). | 14. <i>Cyclotella rotula</i> (E.). | 21. Grain of pine pollen (<i>Pinus rigida</i>). |
| 7. <i>Pinnularia radiosa</i> (?) (K. S.). | 15. <i>Synedra</i> sp. (E.). | 22. Foraminifera (Rotalia). |
| 8. <i>Amphora</i> sp. (K.). | 16. <i>Diatoma</i> sp. (De C.). | 23. Zoöspore (<i>Ulva</i> ?). |
| 9. <i>Pleurosigma fasciola</i> (E. S.). | 17. <i>Cymbella</i> sp. (Ag.). | 24. Spicules. |
| 10. <i>P. littorale</i> (S.). | 18. <i>Mastogloia smithii</i> (Thw.). | |
| 11. <i>P. strigosum</i> (S.). | 19. <i>Triceratium alternans</i> (Br. Bai.). | |
| 12. <i>Actinocyclus undulatus</i> (K.). | | |

(After Bashford Dean.)

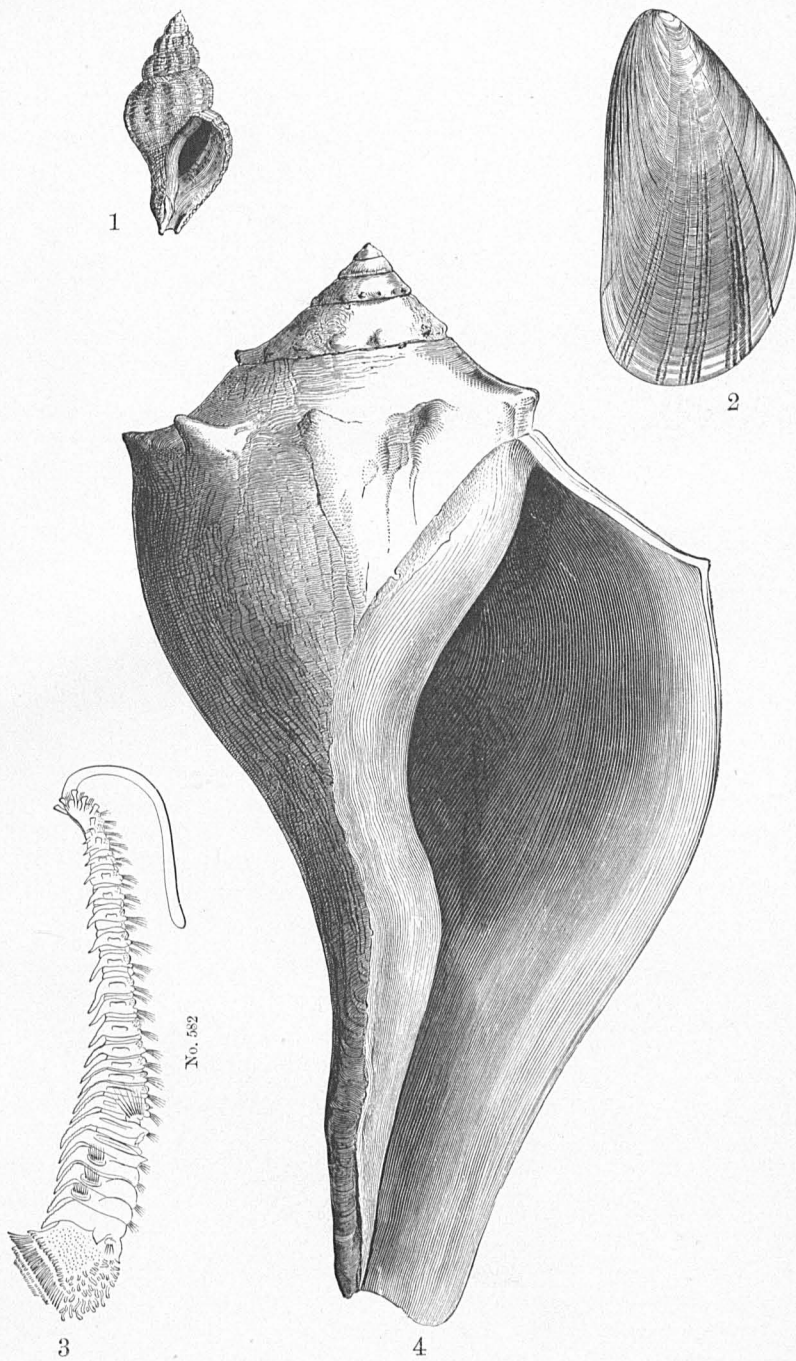
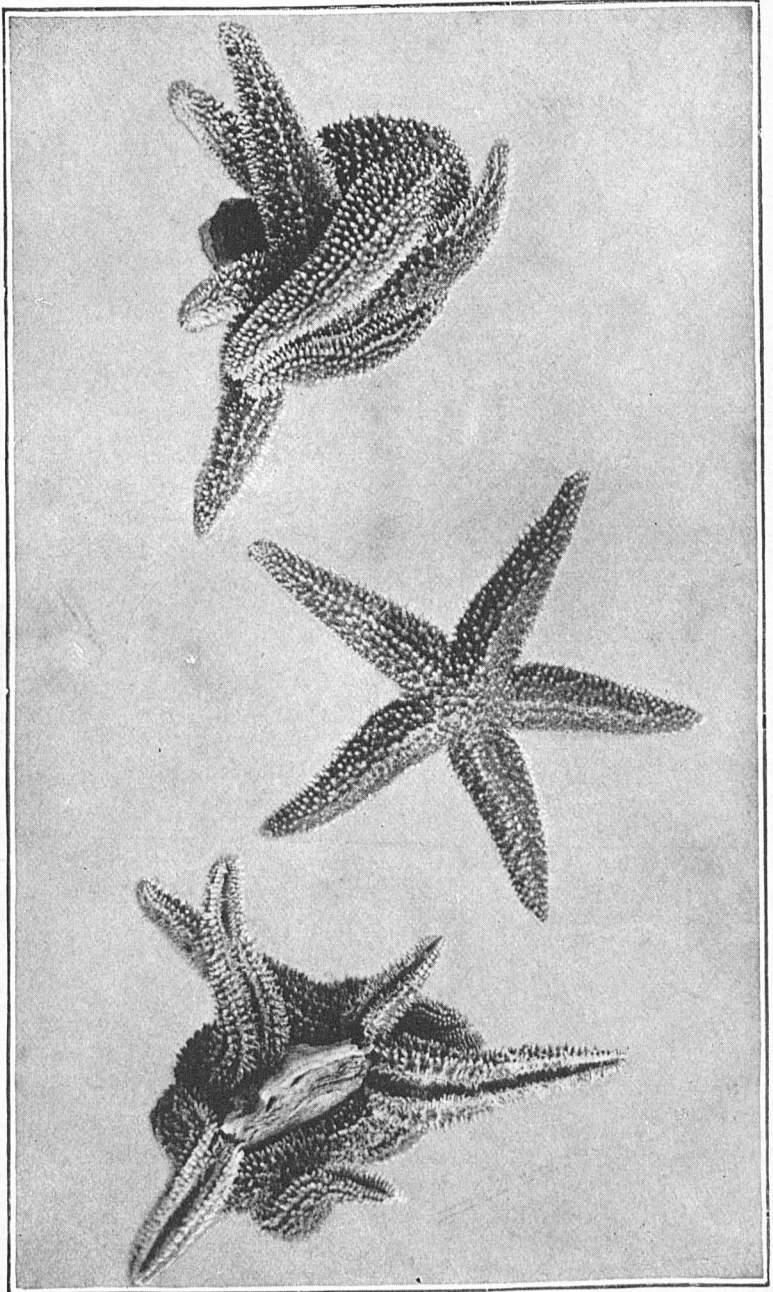
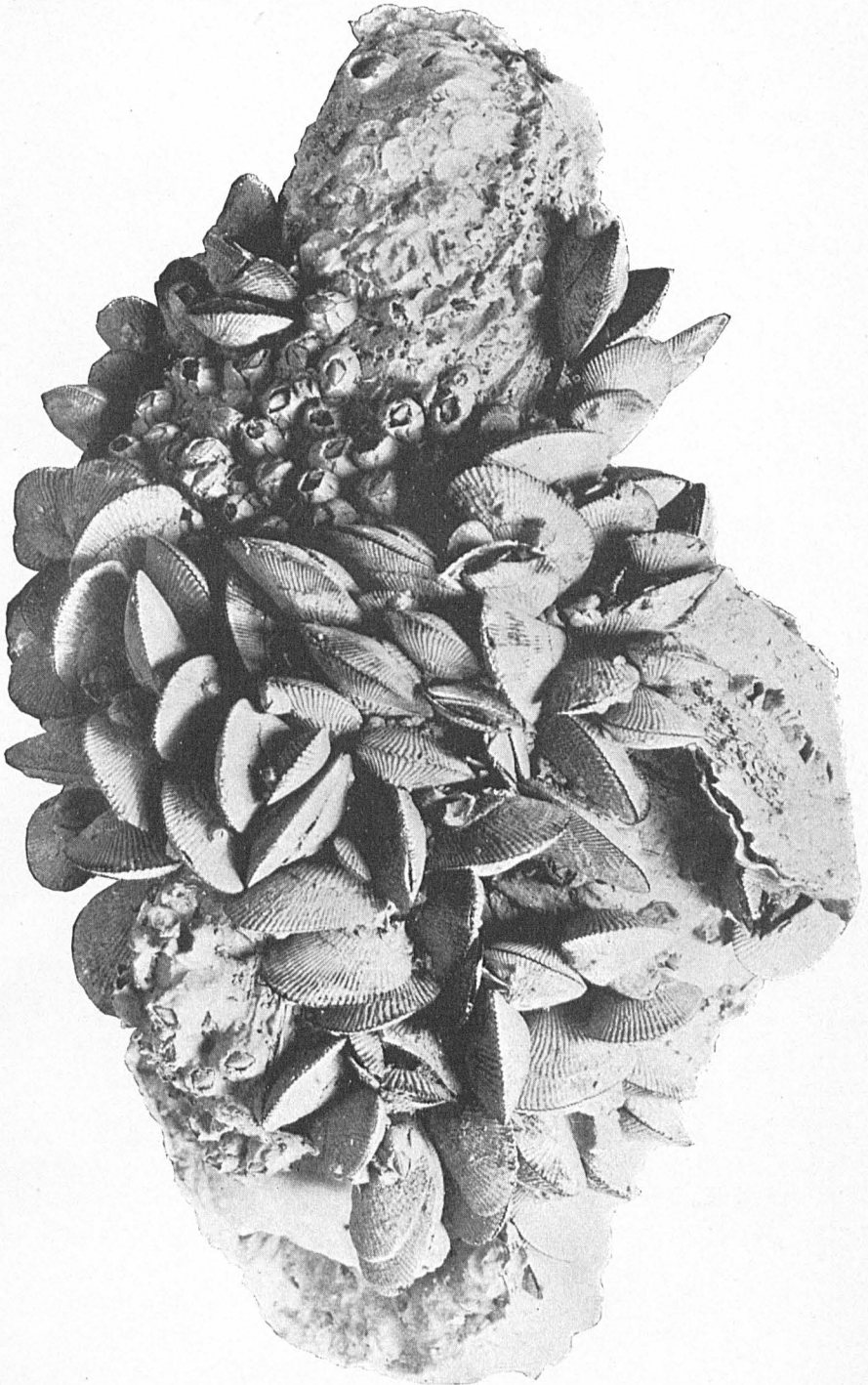

FIG. 1. Drill, *Urosalpinx cinerea*.
FIG. 2. Mussel, *Mytilus edulis*.

FIG. 3. *Sabellaria vulgaris*.
FIG. 4. Periwinkle, *Fulgur carica*.



STARFISH ATTACKING OYSTERS.
[From Fifth Annual Report of Connecticut Bureau of Labor Statistics.]



BUNCH OF OYSTERS FROM GREAT POINT CLEAR REEF. SHOWING GROWTH OF MUSSELS AND BARNACLES.

From Bulletin U. S. Fish Commission, 1895.

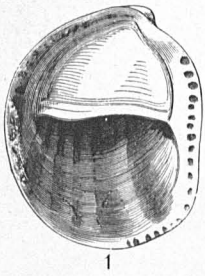

1



3

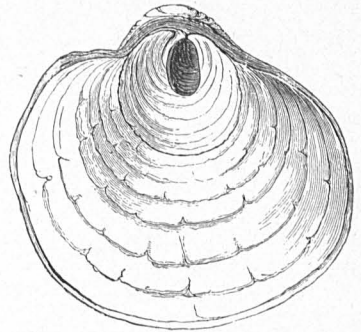

5



2

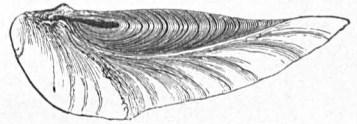

4

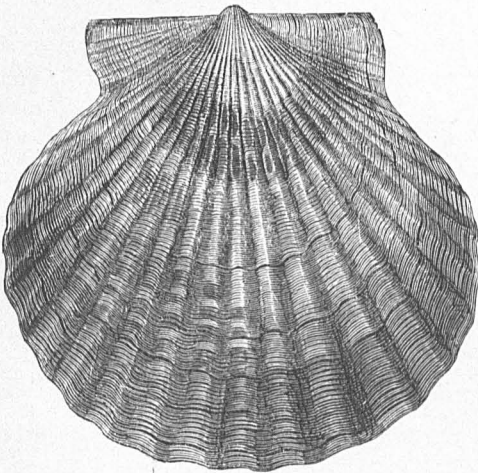

6



7

FIG. 1. "Quarter-decker," *Crepidula fornicata*.
FIG. 2. "Quarter-decker," *Crepidula plana*.
FIG. 3. "Quarter-decker," *Crepidula convexa*.
FIG. 4. Jingle, *Anomia glabra*, profile view.
FIG. 5. The same, lower side.
FIG. 6. Scallop, *Pecten irradians*.
FIG. 7. Oyster attached to pebble.

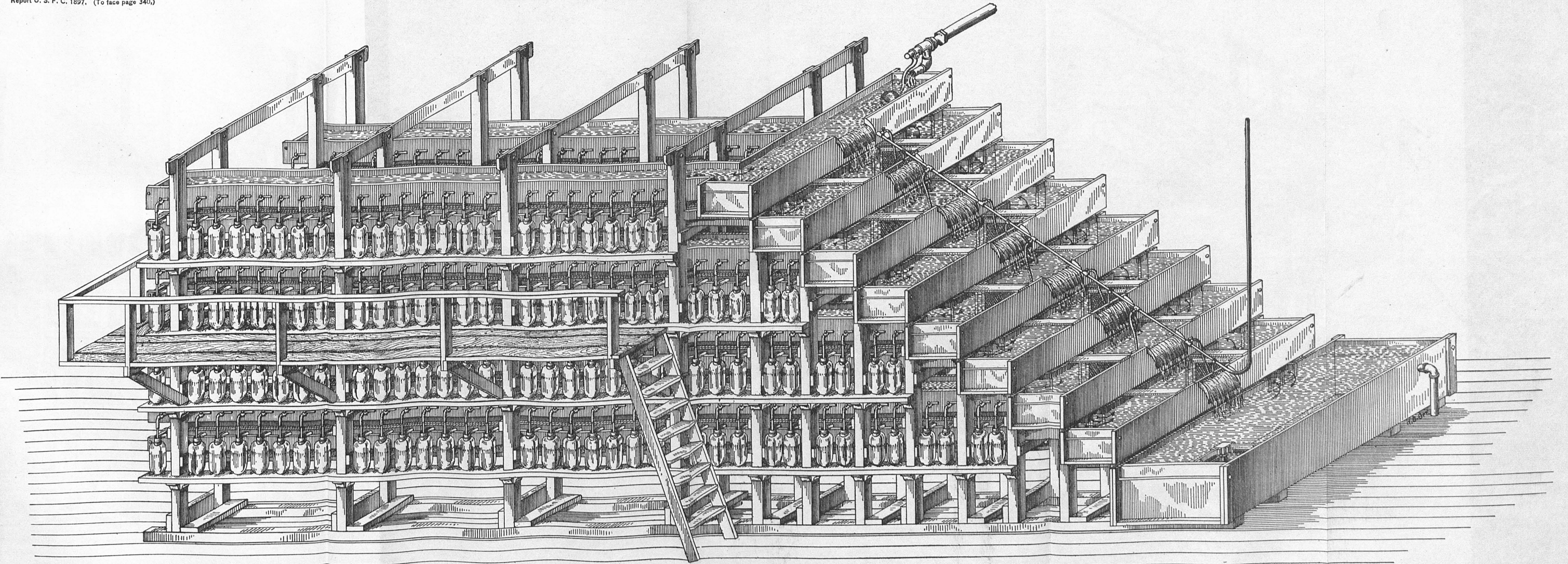

VIEW OF BATTERY FOR HATCHING WHITEFISH.