



# NOAA Technical Memorandum NMFS-SEFC-197

## REVIEW OF THE 1986 TEXAS CLOSURE FOR THE SHRIMP FISHERY OFF TEXAS AND LOUISIANA



**JULY 1987**

U. S. DEPARTMENT OF COMMERCE  
National Oceanic and Atmospheric  
Administration

National Marine Fisheries Service  
Southeast Fisheries Center  
Galveston Laboratory  
Galveston, Tx 77551 5997



# NOAA Technical Memorandum NMFS-SEFC-197

## REVIEW OF THE 1986 TEXAS CLOSURE FOR THE SHRIMP FISHERY OFF TEXAS AND LOUISIANA

By

Edward F. Klima, James M. Nance, Peter F. Sheridan,  
K. Neal Baxter, Frank J. Patella and Dennis B. Koi

---

U. S. DEPARTMENT OF COMMERCE  
Malcolm Baldrige, Secretary

National Oceanic and Atmospheric Administration  
Anthony J. Calio, Administrator

National Marine Fisheries Service  
William E. Evans, Assistant Administrator for Fisheries

---

**JULY 1987**

---

This Technical Memorandum series is used for documentation and timely communication of preliminary results, interim reports, or similar special-purpose information. Although the memoranda are not subject to complete formal review, editorial control, or detailed editing, they are expected to reflect sound professional work.

REVIEW OF THE 1986 TEXAS CLOSURE FOR THE SHRIMP FISHERY

OFF TEXAS AND LOUISIANA

by

Edward F. Klima  
James M. Nance  
Peter F. Sheridan  
K. Neal Baxter  
Frank J. Patella  
Dennis B. Koi

JULY 1987

1986 TEXAS CLOSURE REPORT

Table of Contents

<u>INTRODUCTION</u> .....	1
<u>MATERIALS AND METHODS</u> .....	3
<u>Fisheries Statistics</u> .....	3
<u>Statistical Treatment</u> .....	4
<u>Social Survey</u> .....	5
<u>RESULTS</u> .....	6
<u>1985 CLOSURE/BIOLOGICAL YEAR</u> .....	6
<u>Louisiana</u> .....	6
<u>Brown Shrimp Inshore Fishery</u> .....	6
<u>Brown Shrimp Offshore Fishery</u> .....	6
<u>White Shrimp Offshore Fishery</u> .....	8
<u>Texas</u> .....	9
<u>Brown Shrimp Inshore Fishery</u> .....	9
<u>Brown Shrimp Offshore Fishery</u> .....	9
<u>White Shrimp Offshore Fishery</u> .....	12
<u>Overview</u> .....	12
<u>1986 TEXAS CLOSURE</u> .....	13
<u>Recruitment</u> .....	13
<u>Louisiana</u> .....	13
<u>Texas</u> .....	15
<u>Postlarval Brown Shrimp Index -</u>	
<u>Galveston Bay</u> .....	15
<u>Juvenile Brown Shrimp Indices -</u>	
<u>Galveston Bay and Sydnor Bayou</u> .....	16
<u>CPUE Values for Selected Texas Bays</u> ..	16
<u>Bait Shrimp Index</u> .....	17
<u>Inshore Fisheries</u> .....	17
<u>Louisiana</u> .....	17
<u>Texas</u> .....	18
<u>Size Distribution</u> .....	19

<u>Offshore Fisheries</u> .....	19
<u>Louisiana</u> .....	19
<u>Texas</u> .....	21
<u>Size Distribution</u> .....	23
<u>Number of Shrimp</u> .....	24
<u>Discards</u> .....	25
<u>Offshore Shrimp Size</u> .....	25
<u>Estimate of Discarding from Interviews</u> ...	25
<u>Vessel Mobility/Activity</u> .....	28
<u>State Landings</u> .....	28
<u>Home Port</u> .....	29
SOCIAL SURVEY.....	30
<u>FCZ Closure</u> .....	32
<u>Vessel Mobility</u> .....	35
<u>Employment Effect</u> .....	36
DISCUSSION.....	38
SUMMARY.....	44
<u>The 1985 Fishery</u> .....	44
<u>The 1986 Fishery</u> .....	45
<u>LITERATURE CITED</u> .....	48

## INTRODUCTION

The implementation of the Gulf of Mexico shrimp fishery management plan (FMP) in May 1981 permitted, for the first time, closure of the brown shrimp fishery from the coastline to 200 nautical miles off the Texas coast. The objectives of the Texas closure management measure were to increase the yield of shrimp and to eliminate waste caused by discard of undersized shrimp in the fishery conservation zone (FCZ). According to the FMP, shrimp yield would be increased by protecting shrimp from fishing during the period when they were predominantly small and were growing rapidly. Discards would be reduced by eliminating the count restriction in order to allow all shrimp caught to be landed. The Gulf of Mexico Fishery Management Council (GMFMC) agreed to continue this seasonal closure of the brown shrimp fishery off the Texas coast in 1982, 1983, 1984, 1985 and again in 1986. The 1986 Texas Closure was implemented from 10 May to 2 July 1986, but unlike other years the area closed was only from the coastline to 15 nautical miles off the Texas coast. It was determined by the Council that this type of closure would still allow small brown shrimp to be protected from harvest but would also allow the taking of larger brown shrimp by fisherman in deeper waters.

The Texas Parks and Wildlife Department sets the closing and opening dates for the fishery by assessing abundance, size, and growth rate of shrimp in Texas waters during April and June (Bryan, 1985). Prior to the FMP, Texas law closed the territorial sea from the shoreline out 9 nautical miles for 45 days during mid-May to mid-July 1960-1980 (60 days in 1976). Texas's objective was to insure that a substantial proportion ( $\geq 50\%$ ) of shrimp in Gulf waters had reached 65 tails/lb or 112 mm total length by season's opening. With the present FMP, the closed portion of the FCZ is closed and opened in conjunction with the Texas territorial sea closure. The 1981-1986 closures have all exceeded the historical 45-day closure by 5-10 days (Table 1).

The purposes of this report are to provide information to determine how well the objectives of the Texas closure regulations

were achieved in 1985 and 1986 and to determine if a 15 nautical mile closure meets all the objectives of the closure regulations as effectively as a 200 nautical mile closure. This report reviews and analyzes the characteristics of the Texas and Louisiana fisheries west of the Mississippi River and describes the catch, fishing effort, relative abundance and recruitment to the offshore fishery from May 1985 to August 1986. The report also discusses the social and economic impacts experienced by not only the shrimp fishermen, but the shrimp industry in general along the northwestern Gulf of Mexico coasts during the closure period.

## MATERIALS AND METHODS

### Fisheries Statistics

A collection of detailed catch statistics describing the U.S. Gulf of Mexico shrimp fishery (since 1956) is compiled by and available from the Southeast Fisheries Center (SEFC), Economics and Statistics Office (ESO). The procedures used to collect them are described by Klima (1980). The statistics consist of catch, recorded as pounds of shrimp (heads-off); fishing effort, recorded as either 24 hours of actual fishing time or numbers of trips; and size composition of catch, expressed in eight "count" or size categories representing number of shrimp tails per pound (<15, 15-20, 21-25, 26-30, 31-40, 41-50, 51-67 and  $\geq$ 68). Starting in May 1982, ESO recorded pounds caught in size categories larger than 68 count as follows: 68-80, 81-100, 101-115 and 116 count or greater.

To analyze the effects of the Texas closure, only commercial catch statistics from areas west of the Mississippi River (statistical subareas 13-21) were examined (Fig. 1). These data were used to compute catch per unit effort (CPUE) as pounds per 24 hours of fishing or as pounds per trip. The number of shrimp caught was estimated by multiplying the pounds caught in each size category by the mid-point of the size category, and in the case of <15 and  $\geq$ 116 categories, by 15 and 116, respectively. Margo Hightower<sup>1</sup> and Tom Dawley<sup>2</sup> provided specific information concerning the Texas and Louisiana inshore and offshore shrimp fisheries relative to fleet activities, changes in the fleet, number of trips, discards and specifics of catch and effort for

---

<sup>1</sup>Dept. of Commerce, NOAA, NMFS, SEFC, Galveston Laboratory, 4700 Avenue U, Galveston, Texas 77550

<sup>2</sup>Dept. of Commerce, NOAA, NMFS, SEFC, Room 1000, 600 South St., New Orleans, Louisiana 70130

the fishing area during 1985 and 1986.

Information on the size of shrimp at sea during and immediately after the Texas Closure was obtained from routine SEAMAP sampling by the NOAA ship OREGON II, shrimp tagging studies by the NOAA ships CHAPMAN and OREGON II, and from State of Texas vessels operating in the territorial sea. Sampling procedures are described in SEAMAP documentation. Two efforts were made to obtain an estimate of shrimp biomass and value lost by discarding along the Texas coast. The first was NMFS port agent interviews of vessels returning to port. Captains were asked whether or not discarding took place during each trip and the estimated poundage of shrimp discarded. The second was NMFS log books kept by vessel captains who recorded discard data from each tow.

#### Statistical Treatment

Catch data frequently follow skewed distributions, show heteroscedasticity and have non-additive components. Transformations applied to the original data are often able to alleviate these problems and permit valid statistical analyses of the data employing t-tests and 2-way analysis of variance (ANOVA) (Sokal and Rohlf, 1969). Taylor's (1961) test analyzing relationships between means and variances was applied to the brown shrimp fishing data. It showed that catch data should be transformed to their logarithms, fishing effort data did not need to be transformed, and CPUE data should be transformed to their square roots. The analyses of these transformed data provided statistical support to what the untransformed data showed. The summaries are presented in this report using untransformed data.

The commercial catch data were grouped into biological years May-April since brown shrimp are recruited to the fishery in May of each year. The first and last biological years identified are May 1960-April 1961 (biological year 1960) and May 1985-April 1986 (biological year 1985).

Historical mean monthly catch, mean monthly fishing effort and mean monthly CPUE for the 1960-1984<sup>3</sup> period were compared with the May 1985-April 1986 monthly data via 2-way ANOVA using paired observations. Additional comparisons between the May-August monthly means of the fisheries data for statistical subareas 13-17 and 18-21 for the historical time series (1960-1984) were compared with the 1986 monthly data from May-August, using paired observations in a 2-way ANOVA and in t-tests. The shrimp size distributions for each month were compared with the historical data set and 1985 and 1986 monthly size distributions by graphical analyses. Unless otherwise stated, tests of significance were performed at the 95% level (P = 0.05).

### Social Survey

To determine the social impact of the Texas closure on the shrimp industry along the northwestern and northern Gulf of Mexico, interviews of shrimp vessel captains were conducted by NMFS port agents. At least thirty captains from each of 11 port areas along the coast were interviewed during the week of 13 July 1986. The selected port areas included six Texas areas (Port Isabel, Brownsville, Port Aransas, Freeport, Galveston/Bolivar and Sabine/Port Arthur), three Louisiana areas (Cameron, Delcambre and Houma), one Mississippi port (Pascagoula) and one Alabama port (Bayou LaBatre). Interviews were conducted on the first thirty captains who would talk to the port agent. Questions were asked (read) directly from the form (Table 2), and the captains responses were written exactly as stated. These open ended questions allowed for great flexibility in the responses offered to the port agents.

---

<sup>3</sup>Does not include 1980 data because this data file has not been reconciled at this time.

## RESULTS

### 1985 CLOSURE/BIOLOGICAL YEAR

#### Louisiana

##### Brown Shrimp Inshore Fishery

The inshore Louisiana brown shrimp fishery has averaged 11.0 million pounds  $\pm$  3.9 million pounds standard deviation from 1960-1985 (Fig. 2). Peak production in Louisiana appears to be cyclic in that low production was observed from 1960 to 1966 and above average production on all other years except in 1973 to 1975 and 1979 to 1980. Historically, the Louisiana inshore fishery is concentrated from May through August, with peak production in May and June.

During biological year 1985, the inshore Louisiana brown shrimp fishery had a total production value of 9.31 million pounds; with 8.1 million pounds (87%) being taken in the May through June period. Thus, the inshore fishery experienced a below average year with regards to pounds caught, but it was not significantly below average. This below average inshore catch may have been caused by an early exodus of small brown shrimp into offshore waters during May. Sudden drops in water temperatures caused by late cold fronts moving south from Canada seemed to force the shrimp out of the inland bays and estuaries and into deeper offshore waters where they were caught. Thus, shrimp normally available to the inshore fishery in May, were unexpectedly available to the offshore fishery during May 1985.

Over 80% of the inshore brown shrimp caught during May 1985 were in the greater than 116 count range (116 shrimp/pound). In June only 60% were in this size class and in July the number was reduced to only 15%. These values are typical of historical averages for the shrimp size range experienced in the Louisiana inshore fishery.

##### Brown Shrimp Offshore Fishery

Annual production of brown shrimp from May to April in Louisiana offshore waters has averaged 15.4 million pounds  $\pm$  8.0 million pounds standard deviation from 1960 to 1984. The annual yield

was low in the early 1960's and increased to about 18 million pounds by 1967 and remained near this level through 1972 (Fig. 3). The yield dropped to about 10 million pounds from 1973 through 1975. Thereafter the yield has been above the historical average of 15.4 million pounds, with yields topping about 30 million pounds in 1977 and 1978.

In biological year 1985, the Louisiana offshore brown shrimp fishery produced 24.4 million pounds of shrimp. This production level represents an extreme above average catch when compared to the 23 year average (1960-1984), but only a moderate above average catch when compared to an average catch for the last 10 years (20.7 million pounds; 1974-1984 period).

The monthly pattern of shrimp production in Louisiana for biological year 1985 was compared with historical monthly average pattern (Fig. 4). Only July, August and September exhibited catch values that were below average. Yet, of those that showed above average catch, only May was significantly greater ( $\alpha = .01$ ) than its historical counterpart. It is interesting to note, that all fall and winter months (October-April) showed above average production for brown shrimp. This fact is easily observed when monthly comparisons are made between comparable months during the 1973-1986 period (Table 3). All winter months (January-April) had production values during 1985 that were either the greatest or close to the greatest value experienced during the 1973-1986 period. Peak production months were, however, still May-August.

Biological year 1985 also exhibited an above average amount of effort (days fished). Historically, the annual effort expended in statistical subareas 13-17 has been  $23.9 \times 10^3$  days fished. During biological year 1985  $32.5 \times 10^3$  days of fishing were recorded for the brown shrimp fishery in Louisiana.

The monthly pattern of effort during biological year 1985 was compared with the historical monthly average pattern (Fig. 5). All months, except September, had greater than average effort values, but none were significantly different than their historical counterpart. When monthly comparisons were made between comparable months

and periods (Table 3), effort values during biological year 1985 were always near the greatest range of values during the 1973-1986 period. This trend was also true for monthly CPUE values during the 1985 biological year. The average annual catch per unit of effort (CPUE) value was 749 pounds/day for 1985.

An evaluation of the Louisiana brown shrimp caught by size classes revealed that in the May-August period most of the shrimp caught were in the >68 count or 51-67 count size class range (count = number of tails per pound) (Fig. 6). During the September-April period, a change occurred and most of the shrimp were in the 21-25 count range with 16-20 count shrimp and 26-30 count shrimp also being common. It is also important that the period of large shrimp capture, from September-April was also the period of above average catch values.

#### White Shrimp Offshore Fishery

Biological year 1985 was an outstanding year for the offshore Louisiana white shrimp fishery. Analysis of catch data showed an annual production value of 27.9 million pounds, which is above the historical average (1960-1982) value of 16.3 million pounds. All months were either equal to or above their respective historical monthly average during 1985 (Fig. 7). Four months, November, December, March and April were significantly greater than their respective historical averages, with December and March being significant at the  $\alpha = .01$  level. Peak catch months were, as usual, September-December.

All months during the 1985 biological year were also equal to or greater than their respective historical monthly average with regards to effort (Fig. 8). Both May and December were significantly greater than their historical mean at the  $\alpha = .01$  level and March was significantly greater than its historical mean at the  $\alpha = .05$  level. Peak effort was experienced during the September-December period.

## Texas

### Brown Shrimp Inshore Fishery

Landings for the Texas inshore brown shrimp fishery have been increasing for the past several years. The average catch over the 25 year period (1960-1984) was 2.4 million pounds  $\pm$  2.0 million pounds standard deviation (Fig. 9). The landings in 1979-1985 (May-August period) were 4.2, 5.0, 4.3, 4.3, 5.9, 7.1 and 5.4 million pounds, respectively. All these were well above the 25 year average, with the last three also being above the 1979-1984 average (5.1 million pounds  $\pm$  1.2 million pounds).

The Texas inshore brown shrimp fishery takes place from late April through August. Peak production occurs in June. In biological year 1985, 30% of the total catch occurred in June with 86% of the total 1985 inshore catch occurring during the May-August period. During 1985, a total of 6.3 million pounds of brown shrimp were landed, although only 5.4 million pounds was noted last summer (May-August 1985). During the winter of 1986, small brown shrimp were found in inshore waters early and 0.7 million pounds were caught in March and April (months which normally have no catch). Thus, these 1986 cohorts were caught at the end of the biological year 1985.

The size composition of the inshore catch from May through August was dominated by greater than 68 count shrimp. The shrimp in this size class accounted for 85% of the total inshore landings. Yet, on a monthly basis, this size group accounted for 98%, 93%, 73% and 21% of the total inshore landings for May, June July and August, respectively.

### Brown Shrimp Offshore Fishery

The average annual brown shrimp yield from May to April in Texas offshore waters from 1960 to 1984 was 26.9 million pounds  $\pm$  7.5 million pounds standard deviation (Fig. 10). Peak production occurred in 1967 and 1981 with a yield of 48 and 41 million pounds, respectively. Annual production during biological year 1985 was 27.7

million pounds. This production rate was above average, but not significantly greater than the historical mean. However, the production rate obtained during 1985 was the best since the combined Texas-FCZ closure began, excluding the first year 1981.

Monthly catch values graphically depict why 1985 was a year which experienced above average landings (Fig. 11). The May fishery off the Texas coast was not concentrated on either white or brown shrimp as almost equal amounts of about 600,000 lbs were landed. The dominant size group was 31-40 count brown shrimp. Major brown shrimp fishing zones were in statistical subareas 20 and 21, which produced over 70% of the brown shrimp catch.

No fishing for brown shrimp was permitted from May 20 to July 8, 1985. A daytime fishery from the beach to 4 fathoms for white shrimp was permitted along the entire coast during this period. The total landed catch in June for the daytime fishery was about 42,000 lbs of brown shrimp and 100,000 lbs of white shrimp.

The white shrimp fishery off Texas was not very productive in May and June, with catches of 487,000 and 116,000 lbs, respectively. The July fishery amounted to about 440,000 lbs of predominantly 15-20 and under count shrimp, taken primarily in statistical subarea 18. Few white shrimp were caught in statistical subarea 19, and almost none were caught in areas 20 and 21 during July. The August white shrimp fishery was substantial with approximately 560,000 lbs of predominantly 31-40 count shrimp landed. The fishery was concentrated in statistical subarea 19.

With the opening of the offshore brown shrimp season on 8 July, 8.3 million pounds were taken in July off Texas with 6,800 days of effort, giving a CPUE of 1,223 pounds/day. The highest CPUE (1,353 lbs/day) was observed in statistical subarea 21; however, the CPUE was similar along the entire Texas coast, exceeding 1,100 lbs/day in all areas.

In August, the Texas catch was down to only 5.7 million pounds with a fishing effort of 8,400 days. CPUE averaged 672

pounds/day, ranging from a high of 712 pounds/day in subarea 20 to a low of 578 pounds/day in subarea 21. Thus, only July had an above average production level during this four month period, and it looked as through 1985 would be a below average year.

The 1985 brown shrimp production from May through August amounted to only 14.6 million pounds with 14.0 million pounds being produced in the July through August period. Typical production during July through August has been 24.9, 13.1, 9.8 and 15.3 million pounds in 1981, 1982, 1983 and 1984, respectively. The decrease in the July-August 1985 yield when compared to 1984 was attributed to less fishing effort and smaller size shrimp harvested in the offshore fishery (Table 3). In July through August 1985, a total of 15,200 days of effort was expended, compared to 14,800, 15,700, 10,300 and 15,200 days in 1981, 1982, 1983 and 1984, respectively (Table 3). The average CPUE during July-August was 918 pounds/day in 1985, up from the 819 pounds/day in 1984, but lower than the 1895 lbs/day, 922 lbs/day and 962 lbs/day in 1981, 1982 and 1983, respectively.

September, October and November also had lower than historical average catches, which did not add to an optimistic view of the season. However, production rates increased to above average levels for all of the remaining five months (December-April) of biological year 1985. Only January had a catch value that was not significantly greater than its historical average (Fig. 11). December and March were significantly greater than their respective historical mean value at the  $\alpha = .05$  level and February and April were significantly greater than their respective historical means at the  $\alpha = .01$  level. Historically, production levels during the December-April period have averaged only 2.4 million pounds. Yet during biological year 1985 the December-April period had a landing value of 5.8 million pounds. This greater than average catch of brown shrimp during the last 5 months of biological year 1985 allowed the entire year to have an above average catch rate.

Monthly effort values during biological year 1985 followed a

similar pattern to the one shown for catch (Fig. 12). Below average effort was noted during the May through November period, but above average effort was achieved during the December through April period. The 1985 CPUE values for December-April were also all extremely high when compared to other monthly CPUE values during the 1973-1985 period (Table 3).

July 1985 had the greatest shrimp production rate during 1985 and most of these shrimp were in the 31-67 count range (Fig. 13). As the season progressed, 31-40 count shrimp were the dominant catch during August, with >31 count brown shrimp dominating the catches for the rest of the biological year. Thus, record numbers of large brown shrimp were caught this winter in comparison to most other winters (Table 3).

#### White Shrimp Offshore Fishery

White shrimp were also caught in greater than average amounts during the 1985 biological year. Monthly landings were all greater than average, with the exception of October which had slightly below average landings (Fig. 14). However, only the August catch rate was significantly greater than its historical mean. Along the Texas coast the annual production of white shrimp has averaged 4.8 million pounds (1960-1982 period). During biological year 1985 the production value was 6.7 million pounds. Thus, 1985 showed greater than average production for both brown and white shrimp.

Monthly effort value for white shrimp also showed above average values for most months. Only May, October and December had values which were not greater than average (Fig. 15). However, no effort values were significantly different than their historical mean. Effort values were greatest during the September-November period.

#### Overview

Thus, biological year 1985 had greater than average catch rates for both brown and white shrimp for the entire area from west of

the Mississippi River Delta to the Texas-Mexico border. Total brown shrimp production (inshore and offshore) for the area was 67.7 million pounds, which is greater than the 64 million pounds landed during biological year 1984 and slightly greater than the average yield value of 67.1 million pounds for the 1976-1984 period. Offshore landing for brown shrimp were up this year compared to the last two years (1985 = 52.1 million pounds; 1984 = 42.7 million pounds), but catch from inshore areas was down. During 1984 Texas inshore waters produced 7.1 million pounds, but in 1985 only 6.3 million pounds were produced. In Louisiana during 1984 the total inshore catch value was 14.7 million pounds, but it was only 9.3 during 1985. Thus, 1985 offshore production was up 18% over last year from statistical subareas 13-21, but 1985 inshore catch was down by a factor of 28% when compared to 1984.

#### 1986 TEXAS CLOSURE

In 1986, the territorial sea of the State of Texas and six nautical miles of the FCZ adjacent to those territorial seas were closed to all shrimp fishing from May 10 to July 2, except for a daytime nearshore fishery directed at white shrimp. This section of the report represents an analysis of the shrimp statistics taken during the May-August period of 1986 from statistical subareas 13-21, inclusive.

#### Recruitment

##### Louisiana

As in past years, Louisiana Department of Wildlife and Fisheries monitored the winter and spring hydrological and environmental conditions in coastal Louisiana to indicate the potential productivity for the brown shrimp fishery. Winter and spring hydrological conditions in 1986 were favorable when compared to most years since 1981. Bowman<sup>4</sup> indicated that there were approximately 2.5 million

---

<sup>4</sup>Bowman, Phillip, Louisiana Department of Wildlife and Fisheries, P.O. Box 15570, Baton Rouge, Louisiana, pers. commun.

acres of optimum brown shrimp nursery grounds available in Louisiana in 1986. This is the largest value since 1981 when 3.0 million acres were available to shrimp. In comparison, 1983 had only 1 million acres of optimum brown shrimp nursery grounds available, 1984 had 1.6 million acres available and 1985 had 2.0 million acres available to the shrimp. Overall, this 1986 value indicated that brown shrimp production would be higher in Louisiana than in any previous year since 1981. The total Louisiana brown shrimp catch for the 4 month period from May to August 1986 was 37.1 million pounds. This production value was higher than values for all years since 1981. In 1981 it was 38.3 million pounds. Thus, Bowman<sup>4</sup> predicted correctly that 1986 should be an excellent year for brown shrimp along the Louisiana coast.

Catch information from Louisiana inshore and offshore fisheries in May was used by National Marine Fisheries Service Galveston Laboratory as an indication of total production for biological year 1986 in Louisiana. May catch data indicated a record total production value of 15.0 million pounds of brown shrimp landed. Commercial production was extremely high from Grand Island through Terrebonne Parishes, whereas commercial production was relatively light in the Cameron through Calcasieu areas. Using a regression model of total inshore-offshore catch in May from statistical subareas 13-17, we predicted a record harvest of 50.0 million pounds  $\pm$  10.2 million pounds in Louisiana for the May-April period. Brown shrimp production for this area and time period has averaged only 26.0 million pounds with a low of 7.3 million pounds in 1962 and a high of 49 million pounds in 1973. Brown shrimp production was 33.7 million pounds during 1985.

Even though all indications point to an excellent shrimp harvest from Louisiana waters, caution should be taken in using the estimate of 50.0 million pounds. Preliminary information indicates that more fishing effort was exerted during May 1986 than in most previous years. This increase in fishing effort may have unjustly increased

total production and not truly reflect abundance of the brown shrimp. Therefore, the estimate of 50.0 million pounds based on total production for May may be unrealistically high this year. We have not as yet refined our model to include effort. To date, total production for statistical subareas 13-17 from May-August, has amounted to about 37.1 million pounds.

### Texas

Estimates of the potential yield of brown shrimp from the offshore waters of Texas (statistical subareas 18-21) are made by the National Marine Fisheries Service Galveston Laboratory. The forecast is based on data from research programs which sample postlarval and juvenile shrimp and estimate densities in the Galveston Bay area from February through early June. Collections of immigrating postlarval (PL) brown shrimp from Bolivar Roads yield the earliest indications of the future harvest. Juvenile brown shrimp stocks are then assessed using drop-sampler and mark-recapture techniques in bayous to check growth and abundance of the new-year-class shrimp. Finally, juvenile and subadult brown shrimp are monitored in the bait shrimp fishery during late April through mid-June to give a final account of stock strength before offshore migration.

### Postlarval Brown Shrimp Index - Galveston Bay

Mass movements of postlarval brown shrimp into nursery areas usually occur after water temperatures reach or exceed 60°F. This year bay water temperatures were near 60°F during January and February because of the mild winter experienced along the upper Texas coast. With the warmer than usual winter temperatures, postlarval brown shrimp moved into the bay system early. Higher numbers of postlarval shrimp were caught during February 1986, when compared to any previous February. Only one pulse of recruitment was seen this year. Higher than average numbers of postlarval brown shrimp were caught during February and March, but April values were below average. March 1986 values were, however, below March 1984 and March 1985 values.

### Juvenile Brown Shrimp Indices - Galveston Bay and Sydnor Bayou

Sampling of juvenile shrimp with the drop sampler in the salt marsh at Galveston Island State Park indicated higher numbers of brown shrimp in March 1986 than compared to previous years. Abundance values for April 1986 were below April 1985 values, but comparable to April 1984. Values for May 1986 were less than the previous five May values, except 1984. These 1986 values indicate juvenile brown shrimp were in the Galveston Bay system earlier than usual, but numbers never increased in April and May as in previous years.

Sampling of juvenile shrimp with the drop sampler at Sydnor Bayou also showed lower than usual abundance levels during the late May-early June period. Shrimp moved into the area early in one recruitment pulse and the group also left early and was not replaced by late season recruitment.

### CPUE Values for Selected Texas Bays

Catch rates for the inshore Texas commercial fishery during May 1986 were, with few exceptions, below values reported for May 1985. Most bay systems had average catch rates of only 40 lb/hr during 1986, whereas in 1985, values were around 100 lb/hr. Only Galveston Bay showed a major increase in CPUE values when 1985 and 1986 values were compared (35 lb/hr compared to 48 lb/hr). However, this may be only an artifact resulting from the fishing strategy utilized in Galveston Bay last year. Low CPUE values during 1985 for Galveston Bay were recorded because even though shrimp were abundant, they were smaller than usual and thus, fishing was curtailed due to the poor prices received by the commercial fisherman for the small sized shrimp. If the market would have been better, CPUE values would probably have been greater than shown. Thus, all bays in reality showed a decrease in CPUE values when 1985 values were compared to 1986 values.

### Bait Shrimp Index

Our most reliable estimate of forecasting the brown shrimp crop off the Texas coast comes from data collected from the Galveston Bay shrimp fishery during late April through early June. Using a regression model based on bait shrimp catch per hour from 1960 through 1985, we estimate a harvest off the Texas coast of 25.3 million pounds  $\pm$  8.9 million pounds (Table 4). This value is 2.1 million pounds below the average catch of 27.2 million pounds experienced during the 1960 through 1984 period.

### Inshore Fisheries

Inshore shrimp fisheries of Texas and Louisiana are managed by the respective states. Specific regulations concerning fishing activities are in force for both states, limiting the time of fishing during the day, size of fishing gear, fishing areas and seasons.

#### Louisiana

Historically, the Louisiana inshore fishery is concentrated from May through August, with peak production during May and June. The May-August 1986 catch in Louisiana for inshore waters amounted to 14.3 million pounds, with 98% of the total catch in May and June alone. This year's inshore production was higher than the 9.3 million pounds produced during the 1985 May-August period, but lower than most other years since 1981. Inshore production was 14.9, 12.1, 15.1, 15.2 million pounds for 1984, 1983, 1982 and 1981, respectively. Thus, the 1986 inshore catch is lower than all years since 1981, except 1983 and 1985.

In 1986, May inshore production was 7.2 million pounds with June production at 6.8 million pounds. Catch values dropped quickly after June, with a July catch of 0.2 million pounds and an August catch of only 0.05 million pounds. No early migrations of small brown shrimp from inshore waters to offshore waters occurred this year in comparison with 1985.

The size composition of the Louisiana catch in 1981 during the peak months was dominated by greater than 68-count shrimp. In 1982, ESO agents collected specific size information of shrimp smaller than 68-count. Results have shown that the size composition in Louisiana has been greater than 116-count shrimp every year since 1981, and 1986 was no exception. The May-August 1986 catch was also predominantly composed of shrimp in the 116-count size group (Table 5). This group accounted for 51% of the shrimp landed, whereas the greater than 68-count groups accounted for 97% of the shrimp landed in inshore Louisiana.

#### Texas

Landings for the Texas inshore brown shrimp fishery have been increasing for the past several years. This shrimp fishery takes place from late April through August. Peak production in Texas waters occurs in June. The total inshore catch for Texas during the May-August period was 5.2 million pounds, with 0.7 million pounds caught during the January-April period. Thus, a total of 5.9 million pounds of brown shrimp have been caught thus far in 1986. This value was above the 5.4 million pounds caught in 1985, but below the 7.1 million pounds landed in 1984.

The monthly catch rates during 1986 peaked in May and June, with a production level of 2.3 million pounds in May and 2.2 million pounds in June. These two months above accounted for 76% of the total 1986 (January-August) catch. Production levels were 0.6 million pounds in July and only 0.1 million pounds in August. Thus, 1986 had a similar monthly catch trend when compared with other years.

This year Matagorda Bay had the major inshore production during the May-July period with 1.5 million pounds. Following close behind this inshore production level was Aransas Bay with 1.3 million pounds and Galveston Bay with 1.1 million pounds. Both Corpus Christi Bay and San Antonio Bay had production values below the one million pound mark. Galveston Bay was the only Texas bay to have any inshore

brown fishery in August with 96.6 thousand pounds landed.

The size composition of the inshore catch from May through August 1986 was comparable to all previous years since the time ESO agents began to collect on the specific size categories large than 68-count. In May 41% of the inshore catch was composed of shrimp greater than 116-count, with 91% greater than 68-count (Table 6). In June only 23% of the inshore catch was in the greater than 116-count group, with 89% of the catch in the greater than 68-count group.

### Size Distribution

Unlike the 1985 season, in which inshore size distribution of brown shrimp caught in Louisiana or Texas was similar, marked differences between the two states were seen in size composition during the 1986 May-August period (Table 7). The average size count in May was 107 and 122 shrimp/pound in Texas and Louisiana, respectively, whereas in June the counts were 96 and 116 shrimp/pound. These values indicate that much smaller shrimp were being taken in both states during the initial 1986 period, when compared to the same period in 1985 (Klima et al., 1986). In July the size count was 88 and 101 shrimp/pound for Texas and Louisiana, respectively, with Texas having the same values as during July 1985. Louisiana, on the other hand, again has smaller shrimp taken in 1986 in comparison to 1985. During August 1985 no size class information was available from Louisiana, but average count was 56 shrimp/pound in Texas. This year August values were 48 and 58 shrimp/pound for Texas and Louisiana. Again, so far as Texas was concerned, smaller shrimp were caught in 1986 when compared to 1985.

## Offshore Fisheries

### Louisiana

In May 1986, the fishery off Louisiana produced 7.8 million pounds of brown shrimp, with nearly 8.0 thousand days of fishing effort, for an average CPUE value of 978 pounds/day. Both the catch and effort values represent the greatest level achieved off Louisiana since at least 1973 (Table 3). The CPUE value, on the other hand, although high, was not as great as the values achieved in 1981 and 1985. As in years past, most of the catch (70%) and effort (79%) occurred in the shallow waters of statistical subareas 13-14 (Fig. 16). CPUE in statistical subarea 13 was 1136 pounds/day and was 938 pounds/day in subareas 14. Statistical subarea 15 had moderate levels of production with 0.6 million pounds caught from 914 days of effort (CPUE = 602 pounds/day), but very little production was seen in statistical subareas 16 and 17.

In June, the fishery off Louisiana produced 5.4 million pounds of brown shrimp with a fishing effort of almost 7900 days. The average CPUE computed to 691 pounds/day. These June values were all extremely high when compared to other years through 1973, with the exception of most of the years during the 1976-1981 period (Table 3). About 90% of the production took place within 15 fathoms of water in each of the five statistical subareas. CPUE values were high (1000 pounds/day) in statistical subareas 14 and 17, and moderate (500 pounds/day) in subareas 13, 15 and 16 (Fig. 17). This was unusual since both subareas 13 and 14 usually have the higher CPUE values when compared to CPUE values from subareas 15-17.

The July offshore fishery in statistical subareas 13-17 produced 6.3 million pounds of brown shrimp with an effort of nearly 7500 days of fishing. Average relative abundance (CPUE) computed to 840 pounds/day. Again, all three values were above those experienced during most years through 1973 (Table 3). As usual, moderate-to-high CPUE values were found in statistical subareas 13-15 (Fig. 18) with most of the catch inside 10 fathoms. Yet, high CPUE values were also

found in subareas 16 and 17 (840 pounds/day and 943 pounds/day, respectively). Most of the catch occurred in less than 5 fathoms of water in subarea 16. However, in subarea 17 most of the catch was distributed in deeper water with the greatest percentage of the catch being in 10-25 fathoms of water. This was usual since historically, most of the June-July catch in subarea 17 occurs in waters deeper than 10 fathoms.

In August, the Louisiana offshore fishery produced approximately 3.3 million pounds of brown shrimp with an effort of about 4300 days fished. Average CPUE was 773 pounds/day. These values are highest recorded since the Texas closure began in 1981 (Table 3). High catch and effort values were again recorded in subareas 16 and 17, which produced moderate CPUE values for all offshore Louisiana waters (Fig. 19). CPUE values from all statistical subareas were comparable to August 1985 values, as was catch and effort values from subareas 13-15. Catch and effort values from subareas 16-17 were both much higher than those found during 1985.

Thus, during the May-August 1986 period, 22.8 million pounds of brown shrimp were landed from the offshore fishery. Since 1979, only the 1981 production level of 23.1 million pounds has exceeded this value. Monthly totals for catch, effort and CPUE during this 1986 period each were greater than their respective historical value (Table 8). Statistical analysis of the data, however, showed that only the May values were significantly greater than their historical counterparts.

### Texas

The 1986 offshore production from May through August amounted to 14.0 million pounds with 10.7 million pounds (76%) of the catch being produced in July and August. This is markedly different than most years since 1981, with 96% of the May-August catch being caught in July and August. Production in July and August was 25.0, 13.1, 9.9, 15.3 and 14.0 million pounds in 1981, 1982, 1983, 1984 and 1985,

respectively (Table 3). Thus, the catch experienced in 1986 was the lowest, with the exception of 1983, since the closure of the FCZ began in 1981.

In May 1986, the fishery off the Texas coast was concentrated on brown shrimp and not on the equal mixture of white and brown shrimp as in years past. A little over 1.0 million pounds of brown shrimp were landed with an effort of 2600 days fished. Only 0.2 million pound of white shrimp were taken in the same period.

Most of brown shrimp landed during May 1986 were taken from statistical subarea 21 (Fig. 16). However, relative abundances were around 400 pounds/day in all four subareas (18-21). This average CPUE was quite high in comparison to most levels experienced in years past (Table 3).

With an open FCZ beyond 15 miles, June production was 2.3 million pounds of brown shrimp with an effort of about 3700 days fished (average CPUE = 628 pounds/day). Although this production level was the highest since the closure began, it was comparable to other June levels experienced during pre-closure years (Table 3). Landings and efforts were moderate in subareas 18, 19 and 21, but low in subarea 20. CPUE levels were around 600 pounds/day in all four subareas (Fig. 17).

When the entire offshore fishery was opened on July 2, 1986, fishing effort increased 70% compared with the value in June. In July 1986, effort was about 6350 days fished with a production level of 5.7 million pounds. Average CPUE was 896 pounds/day. Moderate catch and effort values were experienced in statistical subareas 18, 20 and 21, with high levels in subarea 19 (Fig. 18). The highest CPUE value was in subarea 18 (977 pounds/day) with the other three subareas experiencing between 818-919 pounds/day. Most of the landings in each statistical subarea were from water depths of 10-25 fathoms.

In August, the offshore Texas catch was 5.0 million pounds of brown shrimp with an effort of about 6200 days (CPUE = 799 pounds/day). This is the highest relative abundance value in August

since 1973, with the exceptions of 1977 and 1981 (Table 3). Most production was again centered in subarea 19 (Fig. 19), but CPUE values were all moderate in each of the four subareas (18-21). The highest relative abundance was in subarea 19 with a value of 882 pounds/day and the lowest was in subarea 21 with a value of 669 pounds/day.

Thus, during the June-August 1986 period, 13.0 million pounds of brown shrimp were caught with an effort of 16.2 thousand days fished. These values were comparable to the July-August 1985 period when 14.0 million pounds of brown shrimp were caught with a fishing effort of 15.2 days. The data seem to indicate similar amounts of efforts were experienced in both 1985 and 1986, but the value was averaged over 2 months with the FCZ closure in 1985 and over 3 months when the FCZ was partially open in 1986.

#### Size Distribution

The size composition of the commercial offshore catch of brown shrimp from statistical subareas 13-17 from May to August 1986 was dominated by 68-count and smaller shrimp in May, June and July (Fig. 20). In August, the catch was more uniformly distributed among the size groups ranging between 31-40's and larger size groups (Fig. 20). The average number of brown shrimp/pound caught in statistical subareas 13-17 in Louisiana from May to August decreased from about 100-count to approximately 40-count (Table 9). The May 1986 offshore catch averaged 100 per pound but was only 120 per pound in 1985. Little or no difference was observed between 1986 and 1985 in June, July and August average size.

The monthly size distribution for the catch of brown shrimp from subareas 18-21 from May to August 1986 was different from that observed off Louisiana (Fig. 21). In May, the catch was composed of nearly equal amounts of size categories between 31-67, with most in the 31-40 and 51-67 ranges. In June, the average size dropped to about 50 per pound with 2.3 million pounds landed. In July, the 31-67 count range was again the predominant modal group, with large numbers

of medium shrimp landed (Fig. 21). The dominant modal group in August was 31-40 count. The 31-40 size class was also the dominant modal group of brown shrimp caught in August 1981, 1982, 1983, 1984, and 1985 off Texas (Klima et al., 1982, 1983, 1984 and 1985). Thus, 1986 experienced similar trends to previous years in August.

#### Number of Shrimp

In addition to describing the pounds landed by size count, we have converted the size category information into estimated numbers of shrimp caught in Texas and Louisiana, both for offshore and inshore waters. Large numbers of shrimp were caught in Louisiana waters in May and June, but the numbers decreased drastically in July and August (Table 10). The Louisiana combined inshore and offshore fisheries caught about 3.4 billion shrimp from May through August with about equal numbers caught inshore and offshore. In Texas waters about 1.1 billion shrimp were caught from May through August 1986, with the inshore fishery harvesting over 510 million shrimp (Table 10).

In comparing the total number of shrimp landed, it is evident that Louisiana produced more shrimp than did Texas (3.4 billion versus 1.1 billion, respectively) in 1986. One reason was that total production in Texas was only 19.1 million pounds compared to 37.1 million pounds in Louisiana for the May-August period (Table 11). Texas offshore production during this period was only 14.0 million pounds compared to 22.8 million pounds off Louisiana. Also, Louisiana inshore waters produced 14.3 million pounds of small shrimp, whereas Texas only produced 5.1 million pounds.

The inshore fisheries of both Louisiana and Texas combined accounted for a little over half of the number of shrimp landed from May to August. In Louisiana, 1.7 billion shrimp were caught in inshore waters and almost 0.5 billion shrimp were caught in Texas inshore waters (Table 10). Almost 75% of the shrimp caught by the inshore fisheries of Louisiana and Texas were shrimp greater than the 100-count size.

## Discards

### Offshore Shrimp Size

There were several sources of fishery-independent data concerning shrimp sizes during and immediately after the Texas Closure: SEAMAP surveys in state waters by Texas and in federal waters by NMFS, and NMFS shrimp tagging operations (Table 12). Texas surveys were conducted near estuary passes in depths of 1-14 fm during June 22-25, 1986. At that time, brown shrimp exceeded the mean total length needed for opening the season (112 mm) in subareas 18 and 19 but were too small in subareas 20 and 21. Subsequently, the OREGON II surveyed 5-50 fm waters of subareas 18-21 during June 27-July 6, 1986 and found the mean brown shrimp length to be 118 mm. However, shrimp tagging experiments in subarea 21 over a restricted depth range (9-12 fm) recorded undersized brown shrimp 5-9 days after the season opened. Commercial catch and discard of undersized brown shrimp was thus possible off the south Texas coast. Mean pink shrimp lengths exceeded the minimum during all surveys.

### Estimate of Discarding from Interviews

ESO port agents in Texas collected information on shrimp discards along with landings interview data. There were three types of fishing trip records (Table 13): 1) 1,526 complete interviews, in which captains reported landings and discards, even if discards were zero; 2) 120 incomplete interviews in which captains reported only landings (either captains were not asked about discards, or comments on discarding were not recorded); and 3) 4,128 dealer records in which captains were not interviewed at all. Thus, of the 5,774 reported fishing trips to subareas 18-21 by vessels returning to Texas ports during July 2-August 31, 1986, a total of 1,646 trips (28.5%) of those trips were interviewed and 1,526 of those interviews (92.7%) provided discard data (Table 13). Interview coverage of vessel activity was high in subarea 21 and low elsewhere but vessel activity was 2-4 times higher in subareas 18-20 than in subarea 21. Most interviews (92.7%) recorded captains comments on discarding.

An additional 162 interviews reporting discard information were

received containing missing or erroneous information relating to vessel characteristics or shrimp size classes but useful landing data. These data were added to the complete interviews above for a total of 1,688 interviews with discard data.

Several standard procedures were employed in examining data on interview forms. If several depth zones or statistical subareas were fished, discards were divided in proportion to hours fished in each since interviews usually reported only total discards. Discard reports were either in pounds or percentages. The percentage of the catch that was discarded was assumed to be a proportion of the landed, heads off weight.

Weekly brown shrimp landings and discard by statistical subarea and depth zone are presented in Tables 14-18. Over the nine weeks covered by this survey (July 2-August 31), discarding generally occurred in the first four weeks of the season or in week nine. In subarea 18 (Table 14), discarding was high during week 1 in 1-10 fm then tapered to zero by week 4. Maximum proportional discards in subarea 18 were reported during July 2-8 but the maximum discard amount (290 lb; 132 kg) was reported from depth zone 3 during July 16-22. In subarea 19 (Table 15), discarding was scattered from July 9 through August 12. Maximum discards (2.9%; 1,000 lb or 454 kg) were reported from 1-10 fm for July 23-29 unloading dates. In subarea 20 (Table 16), discarding was reported among unloading dates of July 2-29. Maximum proportional discards occurred during the week of July 9-15 in depth zone 4 (1.4%), while the maximum weigh discarded occurred with July 16-22 unloading dates from depth zone 3 (849 lb; 385 kg). For subarea 21 (Table 17), discards were reported every week except August 27-31. Highest proportional discards occurred during August 13-19 in depth zone 8 (5.2%), while 2,820 lb (1,280 kg) were discarded by vessels unloading during August 27-31 after fishing in depth zone 4. For the total Texas coast then (Table 18), discarding occurred primarily in the first four weeks of the season over depth zones 1-6 followed by sporadic reports of discarding in depth zones 3 and 4 into weeks 6-8. Depth zones 1 and 2 and 4 experienced the proportionally highest discarding (0.3%) with the maximum amount discarded in depth zone 4 (6,850 lb; 3,107 kg).

Weekly and cumulative summaries of landings and discards by fishing area are presented in Table 19. Weekly total discard over all subareas was highest (0.4-0.6% of the landings) for July 2-22 unloading dates. Discarding was later reported for August 6-26 unloading dates, primarily in subarea 21. For the whole nine week period, landings were 6.7 million lb (3,059 metric tons) and discards were 13,779 lb (6,250 kg) for a discard rate of 0.2% among shrimpers reporting discards.

Weekly and cumulative landings from incompleted interviews and dealer records are summarized in Tables 20 and 21. There were 120 trips interviewed over the nine week period that did not include discard data and that landed 174,270 pounds of shrimp. An additional 4,128 trips with 4.2 million pounds landed were recorded by shrimp dealers but were not interviewed. Total landings for the nine week period were thus nearly 11.1 million pounds.

The total discard by shrimp vessels fishing off Texas and landing in Texas ports can be estimated from these data. It is assumed that the discarding represented by 1,688 trip interviews was reflective of all 5,774 fishing trips. Thus, the discard rate of 0.2% from those 1,688 interviews was applied to the total landings of 11.1 million pounds for an estimated total discard of 22,748 pounds. At 65 tails/lb (the old Texas legal size limit of 112 mm), this biomass represented a possible discard of 1.5 million shrimp.

Compared with 1985 (Klima et al., 1986), discarding after the 1986 Texas Closure was very low (9.9% vs 0.2%). Maximum proportional discards for any given week-depth zone combination was 5.2% in 1986 versus 46.3% in 1985. Maximum weights discarded for any given week-depth zone combination was 2,820 lb in 1986 versus 22,417 lb in 1985. Total weight and number of shrimp discarded in 1986 were 22,748 pounds and 1.5 million shrimp versus 1.1 million pounds and 72 million shrimp discarded in 1985.

## Vessel Mobility/Activity

### State Landings

Commercial shrimp statistics are recorded with a given state and can be traced to the location of capture. We have utilized these data to depict the percent of each state's landings and its location of capture from June through August 1986 (Table 22).

Shrimp landings in the state of Texas that were from offshore production totaled 4.46 million pounds in June, 7.62 million pounds in July and 7.47 million pounds in August. In the June period 57% of the shrimp landed in Texas were caught off Texas, with 43% of the shrimp being caught off Louisiana. During both July and August 75% of the shrimp landed in Texas were from Texas waters and only 25% were from Louisiana waters.

When percent of 1986 Texas landings caught off each state was compared to 1985 data some interesting facts emerged. During 1985, when the total FCZ was closed off Texas only a small percentage of the brown shrimp landed in Texas were from Texas waters (Fig. 22). Most of the landings for Texas in June were from Louisiana waters (Fig. 23). In June 1986, a larger percentage of the shrimp landed in Texas were from Texas waters (Fig. 22), but even with most of the FCZ off Texas opened to fishing, a large proportion of the shrimp landed were still from Louisiana waters (Fig. 23). During both July and August, data showed that the percentage of Texas landings caught off Texas were quite high during both years, with catches from Louisiana waters being moderate (Fig. 22 and Fig. 23).

Shrimp landings in the state of Louisiana that were from offshore production totaled 5.13 million pounds in June, 6.16 million pounds in July, and 6.77 million pounds in August (Table 22). During all three months over 95% of the shrimp landed in Louisiana was caught in Louisiana waters. Only during July did the percent of Louisiana landings caught off Texas increase above 1%.

When 1986 Louisiana landing values were compared to 1985 values, no detectable differences were seen (Fig. 24 and Fig. 25). During both periods most of the shrimp landed in Louisiana were caught from Louisiana waters.

Shrimp landings in Mississippi from offshore production were mainly caught off Mississippi (Table 22). Shrimp landings in Alabama, on the other hand, were caught in greatest numbers off both Mississippi and Louisiana. Few shrimp were caught in Texas waters. Florida landings were similar to those shown for Mississippi. Most of the shrimp landed in Florida during the June-August period were caught off Florida.

### Home Port

We have further been able to identify home port vessels from each of the Gulf coast states and have made a determination of the percent and pounds landed from June 1 through August 31, 1986 by each selected group (Texas, Louisiana and other). The unknown category is a conglomerate of information from consolidated schedules and, as a result, most probably comprises catches from boats fishing in their respective states. Generally, during the entire June-August period, over 70% of the 18.16 million pounds of shrimp landed in Louisiana were caught by Louisiana vessels (Table 23). Most were caught in Louisiana waters, but a few were taken off Texas.

These 1986 values are comparable to what happened during the 1985 season (Figs. 26-28). Thus, it appears that the FCZ closure off Texas has little effect on the fishing habitats of Louisiana home port vessels. Louisiana vessels seem to fish off Louisiana whether the FCZ is opened or closed.

During the entire June-August 1986 period, between 75%-85% of the 19.6 million pounds of shrimp landed in Texas from offshore production were caught by Texas home port vessels. Yet, unlike Louisiana home port vessels which caught most of their shrimp in waters located off their own state, Texas home port vessels fished off both Texas and Louisiana. In June, 50% of the shrimp landed in Texas were caught by Texas home port vessels fishing off Texas, while another 33% of the shrimp were caught by Texas home port vessels fishing off Louisiana (Table 23). During both July and August about 60% of the shrimp landed in Texas were from Texas home port vessels fishing off Texas, while only about 15% of the shrimp landed were

from Texas home port vessels fishing in Louisiana.

When these 1986 values are compared to what happened during 1985, only the July-August periods were similar (Figs. 29-31). In both 1985 and 1986 during these two months, most of the shrimp landed in Texas by Texas home port vessels, were caught off Texas. When June 1985 and 1986 values were compared it appeared that when the FCZ was closed off Texas, most Texas vessels fished off Louisiana, but landed in Texas (Fig. 29). When most of the FCZ was opened off Texas, Texas home port vessels fished almost equally off both Texas and Louisiana, but still landed almost exclusively in Texas.

Only about 10% of the shrimp landed in either Texas or Louisiana were caught by vessels with home ports in Mississippi, Alabama or Florida (other category) (Table 23). When 1985 and 1986 values were compared, no real differences emerged. It appeared as though vessels with home ports from the other Gulf states (those excluding Louisiana or Texas) landed the shrimp they caught in the state whose waters they fished (Figs. 32-34). Thus, it appeared to make little difference whether the FCZ off Texas was opened or closed as to the actions of these home port vessels.

#### SOCIAL SURVEY

Following the 1986 Texas Closure, a survey was conducted by the National Marine Fishery Service to ascertain the sociological impact of the Texas Closure on the shrimp industry along the Gulf coast. Eleven areas were selected and approximately 30 vessel captains were interviewed from each area. Only responses about vessel mobility and opinions about the FCZ closure were targeted on during this analysis, though other information from the forms will be utilized at a later date. The results of the survey will be discussed within the framework of these two areas of focus.

The FCZ closure aspect was analyzed by both interview area (hereafter called fishing port) and vessel home port. Home ports were determined for each vessel from its documentation number in the Coast Guard vessel operating units file and recording the home port. The distinction between fishing port and vessel home port is made in this analysis because

vessel captains, no matter where they are from, but who all fish a certain area of the Gulf may have different opinions about the closure than the vessel captains who are simply all home ported in a certain location. With regards to vessel mobility, the analysis will be conducted only by vessel home port, since this is the only way to determine the movement of a particular fleet during the closure period.

Results showed that thirty captains each were interviewed from Bayou La Batre, Alabama; Pascagoula, Mississippi; Delcambre, Louisiana; Sabine, Texas; Galveston, Texas; Port Aransas, Texas; and Port Isabel, Texas. In Houma, Louisiana, and Freeport, Texas, 34 interviews each were obtained, whereas Brownsville, Texas, produced 31 interviews and Cameron, Louisiana, had 32 interviews. This made a total of 341 initial interviews conducted in July 1986. Captains from vessels in Fort Myers, Florida, were interviewed in August, to get opinions from 30 Florida vessels, but only five interviews were actually taken. These Florida interviews were not summarized as a Florida fishing port because of the very small sample size, but were included in the home port analyses and the fishing port analyses, if the data were summarized by areas. Thus, a total of 346 vessel captains were interviewed with the social questions.

Chi-squared analysis revealed that responses to questions about the FCZ closure were independent of the date the survey was conducted. Thus, from each port no detectable difference was found when responses from the first half of the week were compared to responses from the last half of the week.

When these 346 vessels were summarized by home ports the following distribution appeared. Fifty vessels were from Florida, 32 vessels were from Alabama and 28 vessels were from Mississippi. Seventy total vessels were from Louisiana with 43 being from the Houma area, 20 being from the Delcambre area and 7 being from the Cameron area. Thus, the remaining 165 vessels were either from home ports in Texas (163) or the east coast of the United States (2). Of the 163 total Texas vessels, 30 were from the Sabine area, 11 were from the Galveston area, 14 from the Freeport area, 31 from the Port Aransas area, 41 from Port Isabel and 36 from Brownsville.

## FCZ Closure

Individual responses about the FCZ closure from each interviewed captain are presented by fishing port in Appendix I. Each response was placed in one of three determined categories. If the captain stated no preference for or against the closure, his response was placed in the no opinion category. If positive comments were made about the closure, the response went into the pro-closure slot and if negative comments were made the third category was assigned.

Analysis of data by fishing port showed that a large proportion of the vessel captains fishing in either Alabama or ports along the lower Texas coast favored a closure in FCZ waters (Fig. 35). A large percentage of the vessel captains fishing off either Mississippi or Delcambre, Louisiana, had no opinion or comment about the closure, whereas most of the captains fishing in either of the other two Louisiana ports or in any of the ports along the upper Texas coast opposed the FCZ closure.

When responses from combined fishing areas were reviewed an interesting pattern emerged (Fig. 36). About 45%-50% of the captains who fished in Louisiana or along the upper Texas coast (Sabine, Galveston and Freeport) were opposed to the FCZ closure. Captains from ports to the east of the opposition area were almost equally divided between a favorable response about the closure (40%) or a no opinion response about the closure (43%). Most of the captains from ports to the west of the area of opposition (i.e., the three lower Texas coast areas including the Port Aransas area, Port Isabel and Brownsville) were in favor of the closures (66%).

Overall, about 35% of the interviewed captains fishing for shrimp in Gulf waters were opposed to the FCZ closure along the Texas coast (Fig. 37). Forty-one percent of the captains who fished in non-Texas waters had no opinion about the closure, but 53% of the captains fishing in Texas waters were in favor of an FCZ closure.

Analysis by vessel home port showed similar results to those obtained with the fishing port investigation (Fig. 38). About half of the vessel captains with home ports from either Florida or Alabama were in favor of a closure of the FCZ along Texas (47% and 56%, respectively). Captains from either Mississippi or Delcambre, Louisiana, again showed little concern about the closure with 75% having no opinion from Mississippi and 65% having no opinion from Delcambre. Over half of the captains from either of the other two Louisiana ports (Houma and Cameron) or from Sabine or Galveston, Texas, showed opposition to the closure with about 56% of the captains giving a negative response from each port. All other Texas ports had captains which gave more favorable responses towards the closure. Captains from either the Freeport or Brownsville area showed the greatest proportion in favor of the closure with 57% and 81%, respectively. Port Aransas or Port Isabel captains on the other hand showed only slight favoritism towards the closure with 45% for and 39% against the closure in Port Aransas and 49% for and 41% against the closure in Port Isabel.

By combining ports into areas, a general overall summary was made (Fig. 39). Ports from Florida-Louisiana had about 35% of the captains which had no opinion about the closure. Captains from ports along the lower Texas coast had the least no-opinion responses with only 12%. Again, as with the fishing port analysis, about 50% captains with home ports from the areas next to the Louisiana-Texas border showed opposition towards the closure. Captains from ports east or west of this area show more favorable responses to the closure, with 41% of the eastern captains and 58% of the western captains in favor of the closure.

Overall, it appeared as though about 35% of the interviewed captains with home ports along the Gulf coast were opposed to the closure (Fig. 40). Outside of the Texas ports, the remaining captains were almost equally split between no opinion about the closure (36%) and favoring the closure (31%). In Texas ports, however, most (49%) of the remaining captains showed a favorable response towards the closures with only 15% having no opinion about the FCZ closure.

In order to determine what type of closure was most popular among the captains who favored an FCZ closure, a separate analysis was undertaken and three different pro-closure categories were determined. If a captain said he liked the FCZ closure, but did not state a given distance, then his response was put into the no limit category. If the captain said he liked the 15 mile closure best (the type conducted in 1986) his response was placed in the 15 mile category, and if a captain said he liked the 200 mile closure (all FCZ closed, as in 1981-1985), then his response was placed in the 200 mile closure category. Only the analysis by home port was conducted.

Most (57%) of the captains from non-Texas ports did not state a given closure distance for the FCZ off Texas (Fig. 41). For the few captains who did have an opinion, half were in favor of a 200 mile closure and the other half were in favor of a 15 mile closure. On the other hand, most (80%) home port Texas captains had an opinion about the distance the FCZ should be closed (Fig. 42). Captains from the Sabine area were almost equally split between no limit (60%) and a 200 mile closure (40%). Captains from the Galveston area were almost all (75%) in favor of a 15 mile closure, whereas Freeport captains were split equally (50% each) between no limit and a 15 mile limit. Captains from the Port Aransas area were split between all three responses. About 30% liked a 200 mile closure and about 20% liked a 15 mile closure. The other 50% of the Port Aransas area captains in favor of a closure did not state a preference. Captains from the two south Texas ports showed the greatest favoritism towards a 200 mile closure. Port Isabel captains were split between a 200 mile closure (50%) and a 15 mile closure (45%). Brownsville captains on the other hand were mostly (69%) for a 200 mile closure of the FCZ, with only a few captains (28%) being in favor of a 15 mile closure.

Overall, the captains from upper Texas ports were equally split (41%) between a no closure limit given and a 15 mile closure (Fig. 43). Captains with home ports in south Texas liked a 200 mile limit closure best (54%). Thus, the data show that for all captains with home ports in Texas who liked the FCZ closure, 20% did not state a distance preference for the

FCZ closure, 34% liked the 15 mile closure best and 46% responded in favor of the 200 mile limit.

It is interesting to note that when the closure analysis responses were split into different classes by number of years a particular Gulf captain had been in the commercial shrimp fishing business, differences in opinions were seen (Fig. 44). Captains who had been shrimp fishing for 10 years or less showed the greatest number in the no opinion category (39%). The other captains within this fishing class were almost equally split in favoritism for or opposition against the closure.

Responses from captains with 11-20 years experience and captains with more than 20 years experience were very similar. Both groups showed that only about 20% had no opinion about the closure. Of those captains who did have an opinion, most (48%) were in favor of a closure of the FCZ and the other 32% were opposed to a closure.

#### Vessel Mobility

Vessels with home ports in Florida showed some change when fishing habits during the 1985 closure and the 1986 closure were compared (Fig. 45). During the 1985 closure 30% of the Florida home port vessels stayed and fished in Florida. The other vessels (if they fished; 12% of the captains did not work) all fished in northern Gulf waters or off Louisiana. During 1986, 30% of the vessels still fished off Florida, but there was a noticeable decrease in the number of vessels that fished off Louisiana. This decrease in vessels off Louisiana was experienced because of an increase in the Florida home port vessels fishing off Texas.

Little difference in fishing habits between 1985 and 1986 was seen with vessels with home ports from either Alabama (Fig. 46), Mississippi (Fig. 47), Louisiana (Fig. 48), or Sabine, Texas (Fig. 49). Alabama vessels fished in the northern Gulf and off Louisiana during both closure periods, whereas Mississippi vessels fished mainly in the northern Gulf both years and Louisiana vessels fished mainly off Louisiana both years. All three Louisiana port areas showed trends similar to the average for the state. Vessels with a home port in Sabine showed a decrease when 1985 and

1986 data were compared with regards to those individuals who did not work. However, even with the FCZ being opened off Texas in 1986, most vessels still fished in Louisiana as they did in 1985.

Noticeable differences between 1985 and 1986 data were seen from the other five port areas located in Texas. Vessels with a home port in either the Galveston or the Freeport area showed an almost symmetrical shift in fishing habits when 1985 and 1986 closure periods were compared (Figs. 50 and 51). In 1985 most vessels fished off Louisiana with some vessels fishing off Texas. In 1986 the reverse was true, with most vessels fishing off Texas. However, Freeport did have more non-working captains in 1985 than Galveston. Vessels from the Port Aransas area showed a slight increase in vessels fishing off Texas and a slight decrease in non-working captains in 1986, but the greatest number of vessels during both years continued to be the ones that fished off Louisiana (Fig. 52). Both Port Isabel (Fig. 53) and Brownsville (Fig. 54) experienced shifts in vessel fishing activity between 1985 and 1986. Both ports showed an increase in those who fished off Texas and a decrease in those who fished off Louisiana during the 1986 season. Brownsville experienced the greatest change. Thus, in general, vessels with a home port in Texas showed a major increase in activity off Texas in 1986, but only a slight decrease in vessel activity off Louisiana when 1986 was compared to 1985 (Fig. 55).

Overall, only vessels with home ports from Florida, Galveston, Freeport, Port Isabel and Brownsville showed a major increase in vessel activity during 1986 off Texas when 1985 and 1986 were compared (Fig. 56). In a similar vein, these were the only ports that showed a similar decrease in number of vessels fishing off Louisiana in 1986 (Fig. 57). All other areas showed no difference in vessel activity when 1985 and 1986 data were compared. Thus, the real difference between the 1985 and the 1986 closure periods was a decrease in number of non-Louisiana vessels fishing off Louisiana in 1986 and an associated increase in the number of vessels that were then fishing off Texas.

### Employment Effect

Analysis of the data revealed that the percentage of captains who did not shrimp during the closure period was high only in the home ports of Florida, Freeport, Port Aransas and Brownsville, Texas. In Florida 12% of the captains interviewed did not shrimp during the closure in 1985 and the majority of them said they were unemployed. The percentage of Florida captains who did not shrimp during the 1986 closure period dropped to only 4%. In Freeport, 29% of the captains did not shrimp during the 1985 closure, but 50% said they were employed at another job. The number of captains not shrimping during the 1986 closure was only 14%. In Port Aransas, 29% of the captains interviewed did not shrimp during the 1985 closure and most (90%) of them also said they were unemployed. During the 1986 closure the percentage that did not shrimp was reduced to 19%, but again most of these captains said they were unemployed. In Brownsville, Texas, 25% of the interviewed captains did not shrimp during the 1985 closure, but a little over half said they were employed at another job. This value was reduced to 11% during the 1986 closure and again most said they were employed at another type of job.

Thus, of the four ports that experienced high numbers of captains who did not shrimp, unemployment was a problem during 1985 only in the Port Aransas area and in Florida. During 1986, unemployment was only a problem in the Port Aransas area, with most of the captains at the other ports shrimping during the closure period.

## DISCUSSION

The abundance of shrimp between 1985 and 1986 appeared to be drastically different. Specifically, the Louisiana brown shrimp catch from May-August 1985 for the inshore and offshore areas amounted to only 25.7 million pounds, whereas in the 1986 the total catch of brown shrimp for the same time period was 37.1 million pounds. Therefore, it is quite apparent the recruitment to the brown shrimp fishery and the relative abundance in 1986 was significantly greater than that in 1985. Further, the Galveston Laboratory forecasted for Louisiana a record annual production of approximately 50 million pounds for biological year 1986.

Abundance of shrimp was also measured by the catch per unit effort and in 1985 CPUE was 982 pounds per day for May-June in Louisiana offshore waters decreasing to 612 pounds per day in July and around 682 pounds per day in August. However, in 1986, CPUE was 830 pounds per day in the May-June period and was maintained at that level also during July and August. That abundant level impacted the fishery by diverting many of the vessels from other areas to continue fishing in Louisiana.

Catch rates in Texas were vastly different. In 1985, for the May-August period, 19.9 million pounds were produced for both the inshore and offshore areas, whereas 19.1 million pounds were produced during the same time period in 1986. We forecasted an annual offshore production of 25.5 million pounds for 1986, slightly below the historical average of 27.1 million pounds. Therefore, when Louisiana and Texas were compared, large differences in production between the two states were noted. These different levels of abundance, we feel, had a direct impact on fishing effort and success of the shrimp fishery in 1986.

The offshore fishery in Texas also experienced quite low measures of abundance in terms of CPUE. When the fishery opened in July, the average CPUE was 896 pounds per day and it had declined to 799 pounds per day by August. In comparison to previous closure years, this was indeed a low level of CPUE because in 1981 the CPUE was almost 2400 pounds per day in July and 1400 pounds per day in August.

When one compares CPUE values between Louisiana and Texas in 1986, it is quite apparent that there was a higher abundance of shrimp in May and June in Louisiana but little or no difference in shrimp abundance

between Texas and Louisiana in July and August. The reason for this was that the usual fishing effort pattern exerted in these two areas was altered by the perception of the fishermen about catch rates in Texas waters. Overall, the perception was that when the Texas closure season opened, extremely high catch rates could be anticipated. However, this did not occur and accordingly, the fishing effort was much lower than what has been seen in other closure years. In 1986, fishing effort was extremely high during the May-June period for the offshore areas of Louisiana topping 15.9 thousand days. In previous years the highest effort experienced in Louisiana with a Texas closure in effect was 14.8 thousand days in 1981. Likewise, in July and August, fishing effort in Louisiana was above the five year average (Table 24). Texas, on the other hand, experienced lower fishing effort than was observed in previous closure years. In fact, only 6.3 thousand days of effort were expended in July and 6.2 thousand days in August; this is considerably below the five year average (Table 24). We feel the reasons for the shift in fishing effort were probably due to the lower than expected levels of production off of Texas coupled with the higher than expected levels of production off of Louisiana. Thus, there was a real shift in fishing effort from Texas to Louisiana in 1986 because of, in our belief, the shift in production levels, rather than because of a change in regulations. Obviously, there were higher levels of fishing effort in June off of Texas than in previously years, since this was the first time the season was open in 5 years. Approximately 3.7 thousand days of fishing effort were experienced off the Texas coast during this time. This level of effort was enough to provide information to the fishermen so that they could make a determination as to where they wanted to fish during the remainder of the season. The unexpected lower catch rates off of Texas probably influenced the fishermen to expend more effort off of Louisiana in 1986 than they had previously done, and to expend less effort off of Texas than they had in years past.

The average size of shrimp in inshore Louisiana waters for the months of May and June in 1986 appeared to be quite similar to that shown during the same time period in 1985. Size counts ranged around 121 count in May and around 116 count in June.

In Texas, there appeared to be some small differences in the average size of the brown shrimp in the inshore areas when 1985 and 1986

were compared. In May and June 1985, the average size count was 114 count and 108 count per pound respectively, whereas in 1986, the average size count in May was 107 and 96 in June. Therefore, the size differences between Texas and Louisiana in 1986 are quite apparent. As stated previously, size counts for inshore shrimp in Louisiana were 121 and 116 for May and June, respectively, and were quite a bit smaller for Texas as 107 and 96 count shrimp were found in May and June in 1986 in Texas inshore waters.

The average size count in July for brown shrimp caught offshore of Texas was 46 count in 1985, whereas it was 44 count in July 1986. However, as compared to other closure years, when the size count were 40-43, the 1986 catch had slightly smaller shrimp. We feel that the early opening of the seasons in both 1986 and 1985 and the abundance of extremely small shrimp in the bay systems during these years, resulted in the capture of smaller shrimp than might have been desired from the standpoint of the fishery management plan. Nichols (1987) has discussed this in his review of the 1986 closure and has indicated a loss in pounds (4-10%) and value (15-19%) caused by the early opening of the Texas season. A delay in the opening to at least July 15 would have resulted in a larger gain in both biological and economic yield. Further, Nichols & Poffenberger (1987) have determined the longer the opening can be delayed up until August, the greater the economic benefit to the fishermen.

It is quite apparent that there were several factors that were quite different between Texas and Louisiana in 1986: 1) the production levels of brown shrimp were vastly different being significantly higher in Louisiana than in Texas; 2) abundance levels were almost identical off Texas and Louisiana in July and August; 3) extremely high catch rates were not experienced off Texas in July; 4) the size of the shrimp in Louisiana were considerably smaller than that found in Texas; and 5) the fishery responded to these changes and fished much heavier on the stock off of Louisiana than they did off of Texas. These factors resulted in higher catches for Louisiana, in fact, record catches for Louisiana during the months of May through August and considerably lower catches for the fishery off of Texas during the same time frame.

Although there was a considerable amount of small shrimp in the fishery at the time it was opened, discards were estimated to be minimal.

Discards amounted to only 23,000 pounds in 1986, as compared to over 1.1 million pounds estimated in 1985. We feel that there was not as much economic incentive this year to discard shrimp because of higher shrimp prices, lower fuel costs, and lower abundances of all sizes of shrimp. Data show that during the May-August period there was at least a \$1.00 a pound difference in what was paid for shrimp in 1986 as compared to 1985 (Table 25). This certainly was a difference between the two closure years. Another difference was in the price paid by fishermen for fuel. In 1985, diesel fuel cost on the average 86¢ a gallon, whereas in 1986, it averaged approximately 40¢ per gallon. These two differences, the higher price for shrimp and the lower price for fuel, coupled to make an extremely profitable year for most shrimp fishermen.

Fishermen interviewed across the northern Gulf displayed different feelings depending on their home port. Fishermen from Florida and Alabama appeared to like the closure. Fishermen from Mississippi and central Louisiana generally had no opinion concerning the closure, whereas fishermen from western and eastern Louisiana and along the upper Texas coast were opposed to a closure. Fishermen from ports along the lower Texas coast were in favor of the Texas closure.

Fleet mobility in 1986 was somewhat similar to what was observed in 1985. During the 1985 closure period, both Louisiana and Texas fishermen primarily fished in Louisiana. After the closure opened, few Louisiana fishermen fished in Texas waters but remained in their own local waters, whereas Texas fishermen fished both Louisiana and Texas. The notable difference in 1986 was that even with the open area for fishing off Texas during June 1986, only 50% of the Texas vessels fished in Texas waters, whereas 33% still fished in Louisiana waters during that period.

For several years shrimp length data from Texas offshore waters has been collected by NMFS and TPW. Analysis of the data by mean length of shrimp per samples compared with sample distance off shore (in nautical miles) indicated that about 86% of the stations with a mean length of shrimp greater than 68 count (112 mm) were within 20 nautical miles of the shore (Table 26), whereas only 79% of the stations were within 15 nautical miles of the coast.

When individual shrimp with length greater than 68 count were

examined, the analysis revealed that 75% of the shrimp smaller than 112 mm were within 15 nautical miles of the beach and 83% were within 20 nautical miles of the beach (Table 27). No shrimp in this size class were found past 40 nautical miles from shore. Thus, these data indicate that a closure of the FCZ out to 20 nautical miles would protect a large proportion of the smaller size shrimp.

Perry Allen<sup>5</sup> has indicated that prior to mid-June there was little violation of the Texas closure waters. However, after mid-June there appeared to be large numbers of violations, especially south of Aransas. Data show that either a 15 or 20 mile closed area probably would be the most beneficial economically and biologically to the shrimp fishery as a whole. However, this assumes that there is compliance with this regulation. This does not appear to be the case at this time and until there is adequate compliance, we would not recommend this type of closure in the future. The rationale behind this is that if fishermen are fishing outside the line legally and they see vessels fishing inside of that line, most fishermen feel that those shrimp are being taken illegally and that they want their fair share. Further, if large numbers of vessels are fishing inside as has been observed this year, the probability of being caught decreases with the number of vessels. The only means of insuring compliance would be voluntary reporting of violaters by the fishermen. It is virtually impossible for any agency to mount a significant effort to prevent people from crossing an imaginary line unless the industry is solidly behind this type of regulation and are willing to commit and to follow through by volunteering information for apprehending violaters.

---

<sup>5</sup>Allen, Perry, Chief Enforcement Officer, Southeast Regional Office, NMFS, Duval Bldg., 9450 Gandy Blvd., St. Petersburg, FL 33702.

## SUMMARY

### The 1985 Fishery

Brown shrimp offshore production in statistical subareas 18-21 from May 1985 to April 1986 amounted to 27.7 million pounds. Over 14.0 million pounds were produced in July-August 1985 compared with 25.0 and 13.1 million pounds produced in July-August of 1981 and 1982, respectively. Moderate catches and moderate levels of relative abundance occurred off the Texas coast in July and August. A peak in CPUE of almost 1,223 pounds/day occurred in July, but dropped to 672 pounds/day in August. Production of brown shrimp from September to December 1985 amounted to 9.7 million pounds with an average CPUE of around 626 pounds/day. These were the highest catch and CPUE values recorded since 1973, with the exception of 1981. In the January-April 1986 period, production amounted to only 3.3 million pounds with the CPUE falling to an average of approximately 393 pounds/day, but these were again the highest levels recorded since 1973.

The offshore brown shrimp catch from statistical subareas 13-17 from May 1985 to April 1986 amounted to 24.4 million pounds. The 6.1 million pound brown shrimp catch in Louisiana offshore waters during the July-August 1985 period was much lower than the 14.0 million pounds produced in Texas waters. The CPUE averaged 625 pounds/day. The September-December Louisiana offshore catch amounted to 3.4 million pounds, down from 4.3 million pounds in 1981, but higher than all other closure years. During this time period the overall CPUE of 642 pounds/day was about the same as was occurring in Texas offshore waters. The catch in January-April 1986 amounted to 3.6 million pounds with an average CPUE of 480 pounds/day, or about 18% higher than in Texas.

In comparing the catch, fishing effort and CPUE with their associated historical values, for Texas and Louisiana offshore waters from September 1985 to April 1986, we found no significant differences in monthly catch off Louisiana, but significant difference in the monthly catch off Texas. Fishing effort was greater than the historical fishing effort off both states. The major differences, however, were the higher catches and CPUEs that occurred off Texas in July and August.

Recruitment to the Texas brown shrimp fishery in 1985 was above

average. Our predicted annual production of 29.0 million pounds from July 1985-June 1986 was very close to the actual catch of 30.4 million pounds and was above the average 26.9 million pounds for offshore production covering the past 25 years.

#### The 1986 Fishery

Recruitment to areas 18-21 in 1986 appeared to be slightly below average. We estimated an annual yield of 25.3 million pounds with a range from 16.4 to 34.2 million pounds for Texas offshore waters. The offshore catch in July-August 1986 from subareas 18-21 amounted to 10.7 million pounds or an estimated annual yield of 17.8 or 22.8 million pounds using historical percent of total caught during July-August.

Louisiana Department of Wildlife and Fisheries indicated that brown shrimp recruitment to Louisiana fisheries would be higher in 1986 than in 1982, 1983, 1984 and 1985. The NMFS forecasted a record catch for Louisiana of up to 50.0 million pounds.

In 1986, the total Louisiana May-August catch was 37.1 million pounds compared to only 19.1 million pounds in Texas. Recruitment levels were vastly different between areas 13-17 and 18-21. This difference in both recruitment and production set the tone for the summer offshore fishery.

Fishing effort was much greater off Louisiana and was much lower off Texas in 1986 compared to 1985. Much of the effort which is normally expended off Texas was diverted to Louisiana because of the perceived higher than normal historical levels of shrimp abundance off Louisiana since abundance levels were more than twice as high in Louisiana than Texas in May.

The catch off Texas in July-August 1986 amounted to 10.7 million pounds compared to 14.0, 15.3, 9.9, 13.1 and 25.0 million pounds in 1985, 1984, 1983, 1982 and 1981, respectively. The average CPUE for this period was 856 pounds/day compared to 918 pounds/day in 1985, 819 pounds/day in 1984, 962 pounds/day in 1983, 922 pounds/day in 1982 and 1,895 pounds/day in 1981.

The July-August 1986 catch off Louisiana amounted to 9.6 million pounds with an average CPUE of 813 pounds/day, whereas the July-August 1985 catch was only 6.1 million pounds with an average CPUE of only 625 pounds/day. The July-August 1986 Texas offshore brown shrimp CPUE were almost identical to Louisiana offshore CPUE for the same time period. In all other closure years the CPUE off Texas has been at least 2 times greater than off Louisiana.

The average size of shrimp in July and August off Louisiana was 58 and 38 per pound, respectively, whereas off Texas the average count was 44 in July and 34 in August 1986.

Home port information indicated that during the June 1 through August 31 period Louisiana vessels predominantly landed in Louisiana and very few Texas vessels landed in Louisiana. Likewise, Texas vessels predominantly caught the majority of shrimp landed in Texas. Louisiana vessels rarely landed in Texas. Over 80% of the offshore landings in Louisiana were caught by Louisiana vessels and between 80-90% of the Texas landings were caught by Texas vessels or boats.

---

Comparative summary of % of offshore state landings by vessels and boats from Louisiana and Texas from June 1 through August 30, 1985 and June 1 through August 30, 1986.

	<u>STATE</u>			
	<u>Louisiana</u>		<u>Texas</u>	
	<u>85</u>	<u>86</u>	<u>85</u>	<u>86</u>
June 1-31	82	81	87	90
July 1-15	81	--	73	--
July 16-30	84	--	74	--
July 1-30	--	83	--	81
August 1-31	86	81	80	82

---

In summary, there are several factors which were different between 1985 and 1986. These are as follows:

- 1) Brown shrimp production of shrimp between Texas and Louisiana were vastly different with extremely high levels of production off Louisiana and slightly below average production off Texas.
- 2) CPUE levels in June, July and August off Texas and Louisiana were almost identical.
- 3) High catch rates off Texas in July were not experienced.
- 4) Shrimp caught in July off Texas averaged 44 count. Smaller than in other closure years except 1985.
- 5) Much of the fishing effort which normally is expended off of Texas during the closure period was expended off of Louisiana because of the high production and good catch rates off of Louisiana. Less effort was expended off of Texas than in previous closure years probably because of production levels in Louisiana rather than a change in the regulations off Texas.
- 6) Average price of shrimp in the 41-50 size count was approximately \$1.00 higher in 1986 than in 1985 and the average price for fuel was 40¢ per gallon in 1986, where it was 86¢ per gallon in 1985.

The goals of the fishery management plan were partially achieved in 1986. Small emigrating brown shrimp were protected and allowed to grow to an average size of 44-count. Discarding was not a problem in 1986 because of the high price received for all sizes of shrimp. However, had the shrimp been protected until July 15, fishermen could have harvested a slightly larger size and experienced a gain in pounds of 4-10% and gain value of 15-19%. Problems were encountered in enforcement of the 15 mile line after mid-June as many vessels were observed violating the closure and fishing illegally inside of the closed area during this time frame. Even though a closure of the FCZ out to 20 nautical miles would protect more than 80% of the shrimp greater than 68 count (112 mm), a total closure of the FCZ would aid enforcement.

## LITERATURE CITED

- Bryan, C. E. 1985. Closure dates for the 1984 Texas gulf shrimp season. Texas Parks and Wildlife Department, Mgmt. Data Series No. 82, 11 p.
- Fishery Statistics of the United States, NOAA, NMFS, 1956-1979.
- Klima, E. F. 1980. Catch statistics - Data needs of the Southwestern South America shrimp populations. WECAF Reports No. 28, pp. 123-130.
- Klima, E. F., P. F. Sheridan, K. N. Baxter and F. J. Patella. 1986. Review of the 1985 closure for the shrimp fishery off Texas and Louisiana.
- Klima, E. F., K. Neal Baxter and F. Patella. 1985. Review of the 1984 Texas Closure for the shrimp fishery off Texas and Louisiana. NOAA Tech. Memo. NMFS-SEFC-156, 33 pp.
- Klima, E. F., K. N. Baxter, F. J. Patella and G. A. Matthews. 1984. Review of the 1982 Texas Closure for the shrimp fishery off Texas and Louisiana. NOAA Tech. Memo. NMFS-SEFC-108, 28 pp.
- Klima, E. F., K. N. Baxter and F. Patella. 1982. A review of the offshore shrimp fishery and the 1981 Texas closure. Mar. Fish. Rev. 44(9-10):16-30.
- Nichols, S. 1987. Impacts of the Texas closure on brown shrimp yields. Final report for 1985. Preliminary report for 1986.
- Nichols, S. and J. R. Poffenberger. 1987. Analysis of alternative closures for improving brown shrimp yield in the Gulf of Mexico. Report to the council.

- Rohlf, F. J. and R. R. Sokal. 1969. Statistical Tables. 253 p.  
San Francisco: W. H. Freeman and Company.
- Sokal, R. R. and F. J. Rohlf. 1969. Biometry. 776 p. San  
Francisco: W. H. Freeman and Co.
- Taylor, L. R. 1961. Aggregation, variance and the mean. Nature  
189(4766):732-735.

Table 1. Comparison of Texas closure dates.

Closure Year	Dates Closed	Length in Days
1981	May 22-July 15	55
1982	May 25-July 14	51
1983	May 27-July 15	50
1984	May 16-July 6	52
1985	May 20-July 8	50
1986	May 10-July 2	54

Table 2. Copy of the social form used during the 1986 season.

U.S. DEPARTMENT OF COMMERCE  
NATIONAL OCEANIC AND ATMOSPHERIC ADMINISTRATION  
NATIONAL MARINE FISHERIES SERVICE

GULF OF MEXICO SHRIMP FISHERY DATA COLLECTION FORM  
(Supplement B)

Vessel Name \_\_\_\_\_  
Interview Date \_\_\_\_/\_\_\_\_/\_\_\_\_ Official Number \_\_\_\_\_  
Vessel Length \_\_\_\_\_ Port \_\_\_\_\_

1. How many years have you been a commercial shrimp fisherman?  
\_\_\_\_\_

2. Did you work as a commercial shrimp fisherman during May 20 through July 8, 1985, the Texas closure period, and May 2-July 1, 1986?

\_\_\_\_\_ 85 / \_\_\_\_\_ 86 (Y or N)

If Yes, approximately how long (weeks if possible) did you work during this period?

\_\_\_\_\_ 85 / \_\_\_\_\_ 86 Where \_\_\_\_\_ 85 / \_\_\_\_\_ 86

If No, you were not a shrimp fisherman, what kind of work did you do?

How long? \_\_\_\_\_ 85 / \_\_\_\_\_ 86 Where \_\_\_\_\_ 85 / \_\_\_\_\_ 86

3. How many crew members do you normally have? \_\_\_\_\_

What did your crew do during 1985 closure period?

	<u>Work</u>	<u>Where</u>	<u>Doing</u>
A.	_____ Y-N	_____	_____
B.	_____ Y-N	_____	_____
C.	_____ Y-N	_____	_____
D.	_____ Y-N	_____	_____

4. What do you think of the Texas seasonal closure?

FCZ \_\_\_\_\_

Texas State Waters \_\_\_\_\_

Table 3. Monthly summary of total offshore brown shrimp catch in millions of pounds, total fishing effort in 1000's of days and CPUE in lbs/day, for Louisiana statistical subareas 13-17, and Texas statistical subareas 18-21 for 1973-1986 (1980 not included).

Area	Jan.		Feb.		Mar.		Apr.	
	13-17	18-21	13-17	18-21	13-17	18-21	13-17	18-21
1973								
Catch	1.1	0.4	0.8	0.3	0.8	0.4	0.5	0.4
Effort	1.6	1.4	2.0	0.7	2.0	1.0	1.2	1.7
CPUE	695	272	414	439	400	350	411	222
1974								
Catch	0.5	1.1	0.4	0.6	0.3	0.5	0.2	0.4
Effort	1.1	1.7	1.0	1.5	0.8	1.5	0.6	1.9
CPUE	448	653	408	427	385	301	308	202
1975								
Catch	0.4	0.7	0.4	0.6	0.4	0.3	0.2	0.2
Effort	0.5	1.8	1.1	1.7	1.0	1.0	0.6	0.0
CPUE	754	407	376	327	388	293	324	0.0
1976								
Catch	0.8	0.5	0.6	0.6	0.4	0.4	0.5	0.5
Effort	1.4	1.3	1.3	2.0	1.0	1.7	1.2	2.1
CPUE	534	384	501	289	401	245	370	227
1977								
Catch	0.5	0.2	0.4	0.2	0.5	0.1	0.4	0.3
Effort	1.8	1.0	1.6	0.9	1.8	0.7	1.8	1.5
CPUE	296	193	249	163	274	149	232	201
1978								
Catch	0.9	0.7	1.1	0.5	1.4	1.2	0.5	0.4
Effort	1.1	2.0	2.1	1.3	3.4	0.9	1.2	1.6
CPUE	836	353	531	371	413	174	438	247
1979								
Catch	0.7	0.7	1.0	0.6	0.8	0.5	0.6	0.4
Effort	1.9	2.3	2.0	2.4	2.3	2.1	2.0	1.5
CPUE	374	312	524	266	361	235	312	293
1981								
Catch	0.2	0.3	0.1	0.1	0.2	0.06	0.08	0.06
Effort	0.6	1.0	0.4	0.4	0.4	0.3	0.04	0.2
CPUE	319	253	329	296	387	228	195	301
1982								
Catch	0.5	0.6	0.6	0.6	0.4	0.2	0.2	0.2
Effort	0.9	1.4	1.2	1.9	1.1	0.6	0.7	0.8
CPUE	549	454	446	317	370	276	281	271
1983								
Catch	0.4	0.3	0.3	0.2	0.4	0.1	0.3	0.2
Effort	1.2	1.0	1.2	1.0	1.1	0.5	0.8	0.8
CPUE	373	261	281	206	331	255	346	215
1984								
Catch	0.4	0.2	0.4	0.2	0.3	0.1	0.3	0.3
Effort	0.8	1.2	0.9	0.9	0.8	0.6	0.8	1.2
CPUE	502	196	382	236	326	227	366	74
1985								
Catch	0.6	0.4	0.5	0.3	0.4	0.2	0.4	0.4
Effort	0.8	1.1	1.3	0.9	1.4	0.9	0.9	0.9
CPUE	734	357	405	326	298	267	519	464
1986								
Catch	1.4	0.9	1.0	1.0	0.8	0.6	0.4	0.8
Effort	2.9	1.6	2.1	2.5	2.2	1.8	0.8	2.8
CPUE	478	547	508	387	497	330	470	349

Table 3. cont. Monthly summary of total offshore brown shrimp catch in millions of pounds, total fishing effort in 1000's of days and average CPUE in lbs/day for Louisiana statistical subareas 13-17, and Texas statistical subareas 18-21 for 1973-1986 (1980 not included).

Area	May		June		July		Aug.	
	13-17	18-21	13-17	18-21	13-17	18-21	13-17	18-21
1973								
Catch	0.8	0.7	2.5	2.8	1.1	7.2	1.3	4.0
Effort	1.9	2.9	3.7	3.0	2.8	7.3	3.2	10.2
CPUE	423	261	673	925	402	989	406	392
1974								
Catch	0.8	0.6	1.1	1.8	2.1	5.9	1.9	7.1
Effort	2.2	2.9	2.3	3.9	3.3	7.3	3.0	10.8
CPUE	374	219	480	455	628	806	637	657
1975								
Catch	1.0	0.5	0.7	2.7	1.5	6.1	1.4	5.4
Effort	1.4	2.2	1.4	3.4	2.0	6.8	2.3	8.2
CPUE	724	208	529	797	723	891	620	651
1976								
Catch	1.4	0.8	3.8	1.2	4.8	6.2	3.1	5.3
Effort	3.2	3.1	5.0	2.5	5.4	7.4	3.6	8.8
CPUE	456	246	770	497	880	839	866	607
1977								
Catch	3.6	0.5	6.4	2.1	5.9	8.6	5.9	8.1
Effort	4.3	3.6	7.7	2.8	6.3	7.5	6.3	9.0
CPUE	839	150	835	771	935	1147	943	891
1978								
Catch	5.3	0.8	5.6	2.6	8.5	5.4	5.1	6.3
Effort	7.7	3.8	8.0	3.8	9.0	5.5	7.2	8.4
CPUE	685	217	708	677	941	982	713	746
1979								
Catch	4.1	0.9	5.7	1.9	4.2	3.9	5.3	3.5
Effort	7.6	3.2	10.4	3.3	14.7	5.6	9.6	6.3
CPUE	536	271	554	582	285	685	555	548
1981								
Catch	5.0	0.4	7.6	-	7.5	10.4	3.0	14.6
Effort	5.8	1.1	9.0	-	8.1	4.4	3.8	10.4
CPUE	861	308	842	-	927	2382	799	1408
1982								
Catch	3.3	0.8	5.3	-	3.3	6.6	1.8	6.4
Effort	5.4	2.6	8.8	-	6.4	5.2	3.4	10.2
CPUE	609	295	604	-	525	1279	522	629
1983								
Catch	1.0	0.5	2.9	0.2	2.6	5.2	2.3	4.8
Effort	2.5	1.8	6.6	0.5	4.2	3.7	4.9	6.7
CPUE	417	294	441	163	415	1414	470	714
1984								
Catch	2.6	0.6	4.5	0.2	3.8	8.8	2.7	6.5
Effort	3.3	2.1	6.5	0.3	6.4	8.2	4.7	9.0
CPUE	769	275	691	748	598	1074	573	723
1985								
Catch	6.9	0.6	4.0	0.0	3.0	8.2	2.5	5.6
Effort	5.7	1.5	5.4	0.0	4.9	6.8	3.7	8.4
CPUE	1221	391	732	2942	612	1223	682	672
1986								
Catch	7.8	1.0	5.4	2.3	6.3	5.7	3.3	5.0
Effort	8.0	2.6	7.9	3.7	7.5	6.3	4.3	6.2
CPUE	978	390	691	628	840	896	773	799

Table 3. cont. Monthly summary of total offshore brown shrimp catch in millions of pounds, total fishing effort in 1000's of days and CPUE in lbs/day for Louisiana statistical subareas 13-17, and Texas statistical subareas 18-21 for 1973-1986 (1980 not included).

Area	Totals and Averages for Jan-Apr.		Totals and Averages for May-June		Totals and Averages for July-Aug.		Totals and Averages for Sept.-Dec.	
	13-17	18-21	13-17	18-21	13-17	18-21	13-17	18-21
1973								
Catch	3.2	1.5	3.3	3.5	2.4	11.2	1.8	7.1
Effort	6.8	4.8	5.6	5.9	6.0	17.5	3.5	15.1
CPUE	480	321	548	593	404	691	590	506
1974								
Catch	1.4	2.6	1.9	2.4	4.0	13.0	3.5	8.4
Effort	3.5	6.6	4.5	6.8	6.3	18.1	4.8	13.5
CPUE	387	396	427	337	633	732	807	575
1975								
Catch	1.4	1.8	1.7	3.2	2.9	11.5	3.1	8.3
Effort	3.2	4.5	2.8	5.6	4.3	15.0	4.1	16.5
CPUE	461	257	627	503	671	771	940	497
1976								
Catch	2.3	2.0	5.2	2.0	7.9	11.5	5.7	10.7
Effort	4.9	7.1	8.2	5.6	9.0	16.5	9.6	19.1
CPUE	452	286	613	372	873	723	590	504
1977								
Catch	1.8	0.8	10.0	2.6	11.8	16.7	5.8	12.6
Effort	7.0	4.1	12.0	6.5	12.6	16.5	8.1	20.7
CPUE	263	177	837	461	939	1019	765	586
1978								
Catch	3.9	1.8	10.9	3.4	13.6	11.7	4.1	10.9
Effort	7.8	5.8	15.7	7.6	16.2	13.9	8.9	24.4
CPUE	555	286	697	447	827	864	451	436
1979								
Catch	3.1	2.2	9.8	2.8	9.5	7.4	4.1	6.4
Effort	8.2	8.3	18.0	6.5	24.3	11.9	11.2	15.0
CPUE	393	277	545	427	420	617	387	420
1981								
Catch	0.6	0.5	12.6	0.4	10.5	25.0	4.3	14.1
Effort	1.8	1.9	14.8	1.1	11.9	14.8	6.6	21.1
CPUE	308	269	852	308	863	1895	654	648
1982								
Catch	1.7	1.6	8.6	0.8	5.1	13.1	2.8	7.3
Effort	3.9	4.7	14.2	2.6	9.8	15.7	6.2	18.0
CPUE	412	330	607	295	524	922	447	403
1983								
Catch	1.4	0.8	3.9	0.7	4.9	9.9	2.5	6.6
Effort	4.3	3.3	9.1	2.3	11.2	10.3	4.7	14.6
CPUE	326	242	43	310	439	962	526	452
1984								
Catch	1.3	0.9	7.1	0.8	6.6	15.3	2.7	5.2
Effort	3.4	3.9	9.8	2.4	11.2	18.6	4.7	14.2
CPUE	395	224	718	295	587	819	575	366
1985								
Catch	2.0	1.4	10.9	0.6	6.1	14.0	3.4	9.7
Effort	4.4	3.8	11.1	1.5	9.7	15.2	5.3	15.5
CPUE	459	353	982	389	625	918	642	626
1986								
Catch	3.6	3.3	13.2	3.3	9.6	10.7	-	-
Effort	7.5	8.4	15.9	6.3	11.8	12.5	-	-
CPUE	480	393	830	524	813	856	-	-

Table 4. Galveston Bay Bait shrimp index values from 1960-1985 (average catch = 26.9 million pounds.

Year	Bait index	Predicted catch in millions of pounds	Actual catch in millions of pounds	Difference in millions of pounds
1960	53.6	29.1	34.5	+5.4
1961	20.8	20.0	13.2	-6.8
1962	26.1	21.5	17.3	-4.2
1963	53.0	29.0	24.6	-4.4
1964	30.2	22.6	18.6	-3.9
1965	41.0	25.6	26.5	+0.9
1966	-	-	31.5	-
1967	89.4	39.0	42.7	+3.7
1968	28.0	22.0	27.9	+5.9
1969	43.5	26.3	24.7	-1.6
1970	70.0	33.7	30.7	-3.0
1971	82.3	37.1	34.5	-2.6
1972	85.6	38.0	35.5	-2.5
1973	18.7	19.4	23.3	+3.9
1974	34.3	23.8	26.4	+2.6
1975	-	-	23.7	-
1976	34.1	23.8	25.7	+1.9
1977	58.1	30.5	34.4	+3.9
1978	40.5	25.5	27.7	+2.2
1979	-	-	16.5	-
1980	45.0	26.7	25.7	-1.0
1981	54.3	29.3	40.0	+10.7
1982	26.3	21.5	21.8	+0.3
1983	12.7	17.8	18.2	+0.4
1984	31.2	22.9	24.1	+1.2
1985	44.9*	29.0	30.4	+1.4
1986	37.2	25.3	-	-

\*Modified bait index model used.

Table 5. Louisiana inshore brown shrimp catch 1986, in 1,000 pounds - Mississippi River to Texas. Does not include pieces.

Size Count	May	June	July	August	Total
15	-	1.4	-	-	1.4
16-20	0.1	25.3	-	0.1	25.5
21-25	-	7.5	-	0.5	8.0
26-30	0.1	4.0	-	3.3	7.4
31-40	6.2	20.1	0.2	13.8	40.3
41-50	44.6	127.1	1.1	10.4	183.2
51-67	46.2	148.3	7.4	6.5	208.4
68-80	413.9	484.7	61.8	4.5	964.9
81-100	726.6	1,226.5	58.1	8.0	2,019.2
101-115	1,699.5	1,790.0	23.6	2.4	3,515.5
>116	4,186.6	2,936.6	47.2	1.2	7,171.6
<b>Total</b>	<b>7,123.8</b>	<b>6,771.5</b>	<b>199.4</b>	<b>50.7</b>	<b>14,145.4</b>

Table 6. Texas inshore brown shrimp catch 1986, in 1,000 pounds.

Size Count	May	June	July	August	Total
15	-	-	-	-	-
16-20	-	0.3	0.8	-	1.1
21-25	-	3.1	0.1	0.1	3.3
26-30	0.1	8.2	0.3	1.3	9.9
31-40	28.0	65.2	13.9	14.5	121.6
41-50	70.9	33.8	28.3	33.6	166.6
51-67	105.2	136.2	97.3	49.1	387.8
68-80	127.8	349.6	150.0	-	627.4
81-100	434.7	592.0	134.0	-	1,160.7
101-115	559.9	479.7	124.3	-	1,163.9
116- >	921.2	503.5	93.3	-	1,518.0
<b>Total</b>	<b>2,247.8</b>	<b>2,171.6</b>	<b>642.3</b>	<b>98.6</b>	<b>5,160.3</b>

Table 7. Mean number of shrimp per pound from inshore waters in 1986.

---

State	May	June	July	August
LA	121	116	101	58
TX	107	96	88	48

---

Table 8. Results of t-tests comparing recent (May-August 1986) monthly fishery values with their respective historical average, (Subareas 13-17).

A. Catch (pounds x 1,000,000)

<u>Month</u>	<u>Recent</u>	<u>Historical</u>	<u>Std. Dev.</u>	<u>Probability</u>
May	7.8	1.7	1.6	>.01**
June	5.4	2.9	2.2	<.05
July	6.3	3.1	2.0	<.05
August	3.3	2.7	1.5	<.05

B. Effort (days x 1,000)

<u>Month</u>	<u>Recent</u>	<u>Historical</u>	<u>Std. Dev.</u>	<u>Probability</u>
May	8.0	2.8	2.1	>.01**
June	7.9	4.2	2.7	<.05
July	7.5	4.3	3.1	<.05
August	4.3	3.5	2.0	<.05

C. CPUE (pounds/day)

<u>Month</u>	<u>Recent</u>	<u>Historical</u>	<u>Std. Dev.</u>	<u>Probability</u>
May	978	533	181	>.05*
June	691	633	197	<.05
July	840	754	226	<.05
August	773	763	213	<.05

\*Significant at alpha = .05 level.

\*\*Significant at alpha = .01 level.

Table 9. Mean number of shrimp per pound from offshore waters (1986).

---

State	May	June	July	August
LA	102	78	59	39
TX	40	52	44	34

---

Table 10. Numbers of shrimp caught in Texas and Louisiana from May-August 1986 (numbers in millions of shrimp).

State	May	June	July	August	Total
LA					
Inshore	863.1	783.8	20.1	2.9	1,669.9
Offshore	789.3	412.2	364.8	126.5	1,692.8
Total	1,652.4	1,196.0	384.9	129.4	3,362.7
TX					
Inshore	241.5	207.5	56.7	4.7	510.4
Offshore	39.0	121.2	249.8	167.1	577.1
Total	280.5	328.7	306.5	171.8	1,087.5

Table 11. May-August catch of brown shrimp in millions of pounds from in-shore and offshore Louisiana waters in statistical subareas 13-17 and in Texas waters in statistical subareas 18-21.

Area	Years							
	1986	1985	1984	1983	1982	1981	1980	1979
Louisiana:								
Inshore	14.3	8.9	14.9	12.1	15.1	15.2	7.3	10.6
Offshore	22.8	16.9	13.6	8.8	13.7	23.1	11.7	19.3
Total	37.1	25.7	28.5	20.9	28.8	38.3	19.0	29.9
Texas:								
Inshore	5.1	5.4	7.1	5.9	4.1	4.2	4.5	2.0
Offshore	14.0	14.5	16.1	10.5	13.9	25.3	12.6	10.1
Total	19.1	19.9	23.5	16.4	18.0	29.5	17.1	14.2

Table 12. Fishery-independent determinations of brown shrimp and pink shrimp lengths during and after the 1986 Texas Closure (10 May-2 July 1986). n = number measured; mm = mean mm total length;  $\pm$ CI = 95% confidence interval of the mean length.

Survey	Vessel	Sampling Dates	Statistical Subareas	Depth (fm)	Brown Shrimp			Pink Shrimp		
					n	mm	$\pm$ CI	n	mm	$\pm$ CI
SEAMAP	Galveston Bay	6/23/25	18	1-9	530	122	2.5	0	-	-
	Matagorda Bay	6/23-24	19	3-12	355	113	1.9	11	171	12.1
	Aransas Bay	6/23-24	20	1-12	604	96	1.8	52	147	7.4
	Laguna Madre	6/22-23	21	1-14	453	101	1.7	113	128	5.2
SEAMAP	Oregon II	6/27-7/6	18-21	5-50	4,785	118	0.6	148	151	4.3
Tagging	Chapman	6/21-28	21	9-11	673	112	1.0	927	122	0.9
	Oregon II	7/7-11	21	9-11	756	108	1.1	244	118	1.7

Table 13. Interview coverage of fishing trips during July 2-August 31, 1986 off Texas and interviews containing discard information. Only trips landing in Texas ports are included since discard data were collected only by Texas port agents. Fractions of trips were apportioned equally to each subarea if more than one subarea was fished on a trip.

Fishing Subarea	Total Trips (T)	Trips Interviewed (I)		Interviews with Discard Data		
		Number	%T	Number	%I	%T
18	1,408	308	21.9	273.2	88.7	19.4
19	2,364	447	18.9	406.7	91.0	17.2
20	1,335	408	30.6	378.4	92.7	28.3
21	667	483	72.4	467.4	96.8	70.6
18-21	5,774	1,646	28.5	1,526	92.7	26.4

Table 14. Weekly brown shrimp landings (L), discard (D), and percent discarded (%D = D/(L+D)) in statistical subarea 18 during 7/2-8/31/86 by unloading dates and depth zones (in 5-fm increments, where zone 1 = 1-5 fm). Landings and discards are from 304 interviews and are given in pounds, heads off.

Unloading Dates	Data	Depth Zones							
		1 & 2	3	4	5	6	7	8	9 & 10
7/2-8	L	1,980	34,634	17,873	1,275	0	3,500	0	0
	D	45	0	0	0	0	0	0	0
	%D	2.3	0.0	0.0	0.0	0.0	0.0	0.0	0.0
7/9-15	L	9,635	36,513	48,732	26,044	38,561	2,491	0	0
	D	0	0	15	5	20	0	0	0
	%D	0.0	0.0	0.0	0.0	0.1	0.0	0.0	0.0
7/16-22	L	710	69,154	43,733	35,509	31,829	12,557	0	0
	D	0	290	0	10	0	0	0	0
	%D	0.0	0.4	0.0	0.0	0.0	0.0	0.0	0.0
7/23-29	L	4,603	15,297	48,939	131,345	35,927	6,930	0	0
	D	0	0	0	0	0	0	0	0
	%D	0.0	0.0	0.0	0.0	0.0	0.0	0.0	0.0
7/30-8/5	L	16,330	11,669	35,803	19,719	18,583	4,832	7,930	2,511
	D	0	0	0	0	0	0	0	0
	%D	0.0	0.0	0.0	0.0	0.0	0.0	0.0	0.0
8/6-12	L	5,395	31,468	5,077	18,767	13,687	5,381	12,433	1,749
	D	0	0	0	0	0	0	0	0
	%D	0.0	0.0	0.0	0.0	0.0	0.0	0.0	0.0
8/13-19	L	3,047	23,725	43,023	26,007	16,766	13,482	0	3,276
	D	0	0	0	0	0	0	0	0
	%D	0.0	0.0	0.0	0.0	0.0	0.0	0.0	0.0
8/20-26	L	18,573	15,513	15,932	21,475	18,068	2,926	0	0
	D	0	0	0	0	0	0	0	0
	%D	0.0	0.0	0.0	0.0	0.0	0.0	0.0	0.0
8/27-31	L	1,016	0	2,412	16,177	35,408	6,315	3,304	3,442
	D	0	0	0	0	0	0	0	0
	%D	0.0	0.0	0.0	0.0	0.0	0.0	0.0	0.0
7/2-8/31	L	61,289	237,973	261,524	296,318	280,910	58,414	23,667	10,978
	D	45	290	15	15	20	0	0	0
	%D	0.1	0.1	0.0	0.0	0.0	0.0	0.0	0.0

Table 15. Weekly brown shrimp landings (L), discard (D), and percent discarded (%D = D/(L+D)) in statistical subarea 19 during 7/2-8/31/86 by unloading dates and depth zones (in 5-fm increments, where zone 1 = 1-5 fm). Landings and discards are from 454 interviews and are given in pounds, heads off.

Unloading Dates	Data	Depth Zones							
		1 & 2	3	4	5	6	7	8	9 & 10
7/2-8	L	13,193	35,516	13,752	1,905	10,296	4,070	1,266	0
	D	0	0	0	0	0	0	0	0
	%D	0.0	0.0	0.0	0.0	0.0	0.0	0.0	0.0
7/9-15	L	31,225	82,151	29,536	46,221	68,894	10,094	10,654	0
	D	0	15	0	0	0	0	0	0
	%D	0.0	0.0	0.0	0.0	0.0	0.0	0.0	0.0
7/16-22	L	5,414	47,946	44,008	50,440	9,380	6,571	0	0
	D	0	0	200	0	0	0	0	0
	%D	0.0	0.0	0.5	0.0	0.0	0.0	0.0	0.0
7/23-29	L	34,046	153,811	70,733	73,817	31,422	0	1,885	0
	D	1,000	0	0	0	0	0	0	0
	%D	2.9	0.0	0.0	0.0	0.0	0.0	0.0	0.0
7/30-8/5	L	25,022	214,969	133,268	57,806	21,869	910	0	0
	D	0	0	0	0	0	0	0	0
	%D	0.0	0.0	0.0	0.0	0.0	0.0	0.0	0.0
8/6-12	L	34,549	190,648	65,479	49,978	7,144	2,700	0	0
	D	0	500	0	0	0	0	0	0
	%D	0.0	0.3	0.0	0.0	0.0	0.0	0.0	0.0
8/13-19	L	31,903	105,485	61,227	71,157	25,105	9,740	0	0
	D	0	0	0	0	0	0	0	0
	%D	0.0	0.0	0.0	0.0	0.0	0.0	0.0	0.0
8/20-26	L	35,754	47,361	73,994	33,516	12,261	0	0	0
	D	0	0	0	0	0	0	0	0
	%D	0.0	0.0	0.0	0.0	0.0	0.0	0.0	0.0
8/27-31	L	760	10,391	58,873	262,807	29,885	0	1,175	0
	D	0	0	0	0	0	0	0	0
	%D	0.0	0.0	0.0	0.0	0.0	0.0	0.0	0.0
7/2-8/31	L	211,866	888,278	550,870	397,120	216,256	34,085	14,980	0
	D	1,000	515	200	0	0	0	0	0
	%D	0.5	0.1	0.0	0.0	0.0	0.0	0.0	0.0

Table 16. Weekly brown shrimp landings (L), discard (D), and percent discarded (%D = D/(L+D)) in statistical subarea 20 during 7/2-8/31/86 by unloading dates and depth zones (in 5-fm increments, where zone 1 = 1-5 fm). Landings and discards are from 410 interviews and are given in pounds, heads off.

Unloading Dates	Data	Depth Zones							
		1 & 2	3	4	5	6	7	8	9 & 10
7/2-8	L	14,220	50,969	25,818	8,735	4,665	0	4,316	1,866
	D	0	100	60	0	0	0	0	0
	%D	0.0	0.2	0.2	0.0	0.0	0.0	0.0	0.0
7/9-15	L	15,200	92,508	52,905	26,901	7,929	7,510	24,097	300
	D	0	520	715	0	35	0	0	0
	%D	0.0	0.6	1.4	0.0	0.4	0.0	0.0	0.0
7/16-22	L	0	81,560	16,223	14,471	5,168	5,055	18,486	0
	D	0	849	0	0	0	0	0	0
	%D	0.0	0.0	0.5	0.0	0.0	0.0	0.0	0.0
7/23-29	L	10,950	112,475	64,858	12,680	50,310	13,391	5,621	6,707
	D	0	240	0	0	0	0	0	0
	%D	0.0	0.2	0.0	0.0	0.0	0.0	0.0	0.0
7/30-8/5	L	25,701	192,658	90,667	31,791	38,345	5,001	28,203	0
	D	0	0	0	0	0	0	0	0
	%D	0.0	0.0	0.0	0.0	0.0	0.0	0.0	0.0
8/6-12	L	14,151	114,133	34,223	65,614	29,825	18,648	4,410	2,226
	D	0	0	0	0	0	0	0	0
	%D	0.0	0.0	0.0	0.0	0.0	0.0	0.0	0.0
8/13-19	L	49,973	39,390	91,105	77,590	50,807	7,634	29,690	3,478
	D	0	0	0	0	0	0	0	0
	%D	0.0	0.0	0.0	0.0	0.0	0.0	0.0	0.0
8/20-26	L	2,486	54,498	75,120	24,035	16,073	5,040	3,758	0
	D	0	0	0	0	0	0	0	0
	%D	0.0	0.0	0.0	0.0	0.0	0.0	0.0	0.0
8/27-31	L	7,739	55,418	27,061	42,414	34,162	22,830	16,491	0
	D	0	0	0	0	0	0	0	0
	%D	0.0	0.0	0.0	0.0	0.0	0.0	0.0	0.0
7/2-8/31	L	140,420	793,609	477,980	304,231	237,284	85,109	135,072	16,947
	D	0	1,709	775	0	35	0	0	0
	%D	0.0	0.2	0.2	0.0	0.0	0.0	0.0	0.0

Table 17. Weekly brown shrimp landings (L), discard (D), and percent discarded (%D = D/(L+D)) in statistical subarea 21 during 7/2-8/31/86 by unloading dates and depth zones (in 5-fm increments, where zone 1 = 1-5 fm). Landings and discards are from 520 interviews and are given in pounds, heads off.

Unloading Dates	Data	Depth Zones							
		1 & 2	3	4	5	6	7	8	9 & 10
7/2-8	L	53,515	91,620	70,015	8,085	0	0	18,435	0
	D	200	800	300	0	0	0	0	0
	%D	0.4	0.9	0.4	0.0	0.0	0.0	0.0	0.0
7/9-15	L	107,378	161,735	186,995	56,300	0	0	600	0
	D	1,000	100	2,820	0	0	0	0	0
	%D	0.9	0.1	1.5	0.0	0.0	0.0	0.0	0.0
7/16-22	L	36,820	121,030	121,490	50,460	75,065	2,210	0	0
	D	0	0	1,440	200	0	0	0	0
	%D	0.0	0.0	1.2	0.4	0.0	0.0	0.0	0.0
7/23-29	L	6,397	146,670	70,430	32,405	15,120	16,010	1,096	0
	D	0	175	0	0	0	0	0	0
	%D	0.0	0.1	0.0	0.0	0.0	0.0	0.0	0.0
7/30-8/5	L	61,686	131,176	75,443	26,677	12,025	12,180	18,355	0
	D	0	0	0	0	0	0	0	0
	%D	0.0	0.0	0.0	0.0	0.0	0.0	0.0	0.0
8/6-12	L	15,217	28,718	78,130	4,500	12,502	8,395	690	0
	D	0	0	0	0	0	0	0	0
	%D	0.0	0.0	1.3	0.0	0.0	0.0	0.0	0.0
8/13-19	L	2,280	74,290	87,698	103,680	33,275	13,880	15,850	0
	D	0	0	200	0	0	0	825	0
	%D	0.0	0.0	0.2	0.0	0.0	0.0	5.2	0.0
8/20-26	L	4,610	62,912	104,270	59,660	16,615	4,695	5,223	0
	D	0	0	100	0	0	0	0	0
	%D	0.0	0.0	0.1	0.0	0.0	0.0	0.0	0.0
8/27-31	L	680	45,611	50,297	65,644	36,760	8,170	0	0
	D	0	0	0	0	0	0	0	0
	%D	0.0	0.0	0.0	0.0	0.0	0.0	0.0	0.0
7/2-8/31	L	288,583	863,762	844,768	407,411	201,362	65,540	60,249	0
	D	1,200	1,075	5,860	200	0	0	825	0
	%D	0.4	0.1	0.7	0.0	0.0	0.0	1.4	0.0

Table 18. Weekly brown shrimp landings (L), discard (D), and percent discarded (%D = D/(L+D)) in statistical subareas 18-21 during 7/2-8/31/86 by unloading dates and depth zones (in 5-fm increments, where zone 1 = 1-5 fm). Landings and discards are from 1,680 interviews and are given in pounds, heads off.

Unloading Dates	Data	Depth Zones							
		1 & 2	3	4	5	6	7	8	9 & 10
7/2-8	L	82,908	212,739	127,458	20,000	14,961	7,570	24,017	1,866
	D	245	000	360	0	0	0	0	0
	%D	0.3	0.4	0.3	0.0	0.0	0.0	0.0	0.0
7/9-15	L	163,438	372,907	318,168	155,466	115,384	10,095	35,351	300
	D	1,000	635	3,550	5	55	0	0	0
	%D	0.6	0.2	1.1	0.0	0.0	0.0	0.0	0.0
7/16-22	L	42,944	319,690	225,454	150,880	121,442	26,393	18,486	0
	D	0	1,139	1,640	210	0	0	0	0
	%D	0.0	0.4	0.7	0.1	0.0	0.0	0.0	0.0
7/23-29	L	55,996	428,253	254,960	250,247	132,779	36,331	8,602	6,707
	D	1,000	415	0	0	0	0	0	0
	%D	1.8	0.1	0.0	0.0	0.0	0.0	0.0	0.0
7/30-8/5	L	128,739	550,472	335,181	135,993	90,822	22,923	54,488	2,511
	D	0	0	0	0	0	0	0	0
	%D	0.0	0.0	0.0	0.0	0.0	0.0	0.0	0.0
8/6-12	L	69,312	364,967	182,909	138,859	63,239	35,124	17,533	3,975
	D	0	500	1,000	0	0	0	0	0
	%D	0.0	0.1	0.5	0.0	0.0	0.0	0.0	0.0
8/13-19	L	87,203	242,890	283,053	278,434	125,953	44,736	45,540	6,754
	D	0	0	200	0	0	0	825	0
	%D	0.0	0.0	0.1	0.0	0.0	0.0	1.8	0.0
8/20-26	L	61,423	180,284	269,316	138,686	63,017	12,661	8,981	0
	D	0	0	100	0	0	0	0	0
	%D	0.0	0.0	0.1	0.0	0.0	0.0	0.0	0.0
8/27-31	L	10,195	111,420	138,643	136,515	136,215	37,315	20,970	5,812
	D	0	0	0	0	0	0	0	0
	%D	0.0	0.0	0.0	0.0	0.0	0.0	0.0	0.0
7/2-8/31	L	702,158	2,783,622	2,135,142	1,405,080	863,812	243,148	233,968	27,925
	D	2,245	3,589	6,850	215	55	0	825	0
	%D	0.3	0.1	0.3	0.0	0.0	0.0	0.4	0.0

Table 19. Summary of Texas brown shrimp landings and discard by unloading date and statistical subarea of fishing activity from trip interviews landings during July 2-August 31, 1986. Fraction of trips were apportioned equally to each subarea if more than one subarea was fished on a trip.

Unloading		Weekly				Cumulative			
Dates	Subarea	Trips	Landings	Discard	%Discard	Trips	Landings	Discard	%Discard
7/2-8	18	30.5	65,623	45	0.1	30.5	65,623	45	0.1
	19	43.5	89,018	0	0.0	43.5	89,018	0	0.0
	20	26.4	87,150	160	0.2	26.4	87,150	160	0.2
	21	62.5	156,140	1,300	0.8	62.5	156,140	1,300	0.8
	18-21	162.9	397,931	1,505	0.4	162.9	397,931	1,505	0.4
7/9-15	18	44.2	174,583	40	0.0	74.7	240,206	85	0.0
	19	61.9	210,019	15	0.0	105.4	299,037	15	0.0
	20	41.3	199,418	1,270	0.6	67.7	286,568	1,430	0.5
	21	89.2	334,348	3,920	0.2	151.7	490,488	5,220	0.1
	18-21	236.6	918,368	5,245	0.6	399.5	1,316,299	6,750	0.5
7/16-22	18	32.5	166,566	300	0.2	107.2	406,772	385	0.1
	19	44.0	168,800	200	0.1	149.4	467,837	215	0.0
	20	21.0	105,512	849	0.8	88.7	392,080	2,279	0.6
	21	57.5	248,245	1,640	0.7	209.2	738,733	6,860	0.9
	18-21	155.0	689,123	2,989	0.4	554.5	2,005,422	9,739	0.5
7/23-29	18	50.6	176,147	0	0.0	157.8	582,919	385	0.1
	19	57.1	286,930	1,000	0.3	206.5	754,837	1,215	0.2
	20	49.5	226,212	240	0.1	138.2	618,292	2,519	0.4
	21	50.9	202,586	175	0.1	260.1	941,319	7,035	0.7
	18-21	208.1	891,875	1,415	0.2	762.6	2,897,297	11,154	0.4
7/30-8/5	18	33.0	119,974	0	0.0	190.8	702,893	385	0.1
	19	65.0	356,272	0	0.0	271.5	1,111,039	1,215	0.1
	20	73.5	324,935	0	0.0	211.7	943,227	2,519	0.3
	21	66.5	227,902	0	0.0	326.6	1,169,221	7,035	0.6
	18-21	238.0	1,029,083	0	0.0	1,000.6	3,926,380	11,154	0.3
8/6-12	18	27.5	115,249	0	0.0	218.3	818,412	385	0.0
	19	56.9	248,800	500	0.2	328.4	1,359,839	1,715	0.1
	20	50.4	227,013	0	0.0	262.1	1,170,240	2,519	0.2
	21	45.2	89,092	1,000	1.1	371.8	1,258,313	8,035	0.6
	18-21	180.0	680,154	1,500	0.2	1,180.6	4,606,534	12,654	0.3
8/13-19	18	35.9	150,526	0	0.0	254.2	938,668	385	0.0
	19	47.4	264,526	0	0.0	375.8	1,624,365	1,715	0.1
	20	48.3	239,853	0	0.0	310.4	1,410,093	2,519	0.2
	21	65.6	225,508	1,025	0.5	437.4	1,483,821	9,060	0.6
	18-21	197.2	850,413	1,025	0.1	1,377.8	5,456,947	13,679	0.3
8/20-26	18	29.0	118,298	0	0.0	283.2	1,056,966	385	0.0
	19	50.0	233,445	0	0.0	425.8	1,857,810	1,715	0.1
	20	56.0	191,494	0	0.0	366.4	1,601,587	2,519	0.2
	21	46.8	160,911	100	0.1	484.2	1,644,732	9,160	0.6
	18-21	181.8	704,148	100	0.0	1,559.6	6,161,095	13,779	0.2
8/27-31	18	20.5	69,256	0	0.0	303.7	1,126,222	385	0.0
	19	28.0	137,539	0	0.0	453.8	1,995,349	1,715	0.1
	20	44.0	219,434	0	0.0	410.4	1,821,021	2,519	0.1
	21	35.5	158,502	0	0.0	519.7	1,803,234	9,160	0.2
	18-21	128.0	584,731	0	0.0	1,687.6	6,745,826	13,779	0.2

Table 20. Weekly and cumulative brown shrimp catch (lb, tails) for trips unloading during July 2-August 31, 1986 that were interviewed without collecting discard data.

Unloading Dates	Subarea	Weekly		Cumulative	
		Trips	Catch	Trips	Catch
7/2-8	18	1	4,154	1	4,154
	19	6	3,131	6	3,131
	20	1	3,633	1	3,633
	21	0	0	0	0
	18-21	8	10,918	8	10,918
7/9-15	18	6	4,806	7	8,960
	19	3	7,932	9	11,063
	20	5	10,455	6	14,088
	21	2	4,130	2	4,130
	18-21	16	27,323	24	38,241
7/16-22	18	0	0	7	8,960
	19	2	3,693	11	14,756
	20	1	1,099	7	15,127
	21	1	995	3	5,125
	18-21	4	5,727	28	43,968
7/23-29	18	2	7,758	9	16,718
	19	0	0	11	14,756
	20	3	2,673	10	17,800
	21	1	5	4	5,130
	18-21	6	10,436	34	54,404
7/30-8/5	18	0	0	9	16,718
	19	2	3,300	13	18,056
	20	2	1,085	12	18,885
	21	1	5	5	5,135
	18-21	5	4,390	39	58,794
8/6-12	18	4	11,512	13	28,230
	19	5	8,697	18	26,753
	20	3	7,783	15	26,668
	21	3	770	8	5,905
	18-21	15	28,762	54	87,556
8/13-19	18	2	1,979	15	30,209
	19	4	10,096	22	36,849
	20	7	8,968	22	35,636
	21	6	1,790	14	7,695
	18-21	19	22,833	73	110,389
8/20-26	18	6	7,359	21	37,568
	19	10	15,745	32	52,594
	20	7	12,064	29	47,770
	21	5	1,900	19	9,595
	18-21	28	37,068	101	147,457
8/27-31	18	1	115	22	37,683
	19	10	9,350	42	61,940
	20	7	16,953	36	64,653
	21	1	395	20	9,990
	18-21	19	26,813	120	174,270

Table 21. Weekly and cumulative brown shrimp catch (lb, tails) for trips with unloading dates during the period July 2-August 31, 1986 which were recorded by dealers but not interviewed.

Unloading Dates	Subarea	Weekly		Cumulative	
		Trips	Catch	Trips	Catch
7/2-8	18	94	98,634	94	98,634
	19	50	85,370	50	85,370
	20	46	99,466	46	99,466
	21	22	35,910	22	35,910
	18-21	212	319,380	212	319,380
7/9-15	18	124	293,197	218	391,831
	19	90	287,230	140	372,600
	20	40	86,940	86	186,406
	21	23	22,636	45	58,546
	18-21	277	690,003	489	1,009,383
7/16-22	18	71	103,728	289	495,559
	19	77	202,886	217	575,486
	20	11	19,129	97	205,535
	21	14	10,710	59	69,256
	18-21	173	336,453	662	1,345,836
7/23-29	18	94	171,695	383	667,254
	19	70	188,956	287	764,442
	20	12	16,624	109	222,159
	21	18	17,620	77	86,876
	18-21	194	394,895	856	1,740,731
7/30-8/5	18	261	228,990	664	896,244
	19	951	363,257	1,238	1,127,699
	20	219	117,094	328	339,253
	21	38	56,630	115	143,506
	18-21	1,469	765,971	2,325	2,506,702
8/6-12	18	99	196,173	743	1,092,417
	19	60	148,995	1,298	1,276,694
	20	12	33,859	340	373,112
	21	21	17,240	136	160,746
	18-21	192	396,267	2,517	2,902,969
8/13-19	18	86	161,440	829	1,253,857
	19	48	147,157	1,346	1,423,851
	20	22	54,164	362	427,276
	21	27	29,235	163	189,981
	18-21	183	391,996	2,700	3,294,965
8/20-26	18	129	155,436	958	1,409,293
	19	77	183,256	1,423	1,607,107
	20	20	37,337	382	464,613
	21	11	9,030	174	199,011
	18-21	237	385,059	2,937	3,680,024
8/27-31	18	142	158,664	1,100	1,567,957
	19	494	271,483	1,917	1,878,590
	20	545	100,350	927	564,963
	21	10	6,500	184	205,511
	18-21	1,191	536,997	4,128	4,217,021

Table 22. Percent of offshore Texas, Louisiana, Mississippi, Alabama and Florida landings caught off each state in 1986.

Percent of Texas Landings caught off each state offshore.

<u>State Caught</u>	<u>June 1-30</u>	<u>July 1-31</u>	<u>August 1-31</u>
TX	54.7	74.6	74.7
LA	42.6	25.3	25.3
MS	0.0	0.0	0.0
AL	0.0	0.1	0.0
FL	0.0	0.0	0.0
Thousand Pounds	4,459.9	7,614.9	7,465.4

Percent of Louisiana landings caught off each state offshore.

<u>State Caught</u>	<u>June 1-30</u>	<u>July 1-31</u>	<u>August 1-31</u>
TX	0.2	4.8	0.2
LA	99.3	94.8	97.8
MS	0.5	0.4	1.9
AL	0.0	0.0	0.0
FL	0.0	0.0	0.0
Thousand Pounds	5,125.4	6,155.2	6,766.3

Percent of Mississippi landings caught off each state offshore.

<u>State Caught</u>	<u>June 1-30</u>	<u>July 1-31</u>	<u>August 1-31</u>
TX	0.0	0.0	0.0
LA	0.0	0.7	6.9
MS	99.7	99.3	93.1
AL	0.0	0.0	0.0
FL	0.3	0.0	0.0
Thousand Pounds	329.1	341.6	181.5

Percent of Alabama landings caught off each state offshore.

<u>State Caught</u>	<u>June 1-30</u>	<u>July 1-31</u>	<u>August 1-31</u>
TX	0.0	4.8	0.6
LA	21.9	38.9	55.0
MS	69.9	51.4	43.1
AL	7.5	4.2	0.6
FL	0.7	0.7	0.7
Thousand Pounds	969.5	1,170.6	949.5

Table 22. continued.

---

Percent of Florida landings caught off each state offshore.

<u>State Caught</u>	<u>June 1-30</u>	<u>July 1-31</u>	<u>August 1-31</u>
TX	0.0	1.3	1.2
LA	0.0	0.0	0.0
MS	4.4	0.6	0.4
AL	0.1	0.0	0.0
FL	95.6	98.6	98.5
Thousand Pounds	1,032.1	1,450.1	1,253.6

---

Table 23. Percent and total pounds landed in millions of pounds (offshore only) by vessels and boats from Gulf States from June through August 1986.

Home Port	Area Landed	Area Fished	Pounds Landed	Total Landings in States	% of Total Pounds
June 1-30					
LA	LA	LA	3.79	5.13	74.1
TX	LA	LA	0.38	5.13	7.4
Other*	LA	LA	0.55	5.13	10.8
Unknown**	LA	LA	0.36	5.13	6.9
LA	LA	TX	0.01	5.13	0.2
TX	LA	TX	0.00	5.13	0.0
Other	LA	TX	0.00	5.13	0.0
Unknown	LA	TX	0.00	5.13	0.0
LA	TX	LA	0.13	4.46	3.0
TX	TX	LA	1.50	4.46	33.4
Other	TX	LA	0.14	4.46	3.1
Unknown	TX	LA	0.13	4.46	3.0
LA	TX	TX	0.04	4.46	0.8
TX	TX	TX	2.25	4.46	50.3
Other	TX	TX	0.20	4.46	3.3
Unknown	TX	TX	0.12	4.46	2.7
July 1-31					
LA	LA	LA	4.46	6.16	72.7
TX	LA	LA	0.35	6.16	5.7
Other	LA	LA	0.58	6.16	9.5
Unknown	LA	LA	0.42	6.16	6.9
LA	LA	TX	0.23	6.16	3.7
TX	LA	TX	0.00	6.16	0.0
Other	LA	TX	0.06	6.16	0.9
Unknown	LA	TX	0.01	6.16	0.2
LA	TX	LA	0.15	7.62	1.9
TX	TX	LA	1.17	7.62	15.3
Other	TX	LA	0.39	7.62	5.2
Unknown	TX	LA	0.22	7.62	2.8
LA	TX	TX	0.13	7.62	1.7
TX	TX	TX	4.56	7.62	59.8
Other	TX	TX	0.72	7.62	9.5
Unknown	TX	TX	0.27	7.62	3.5

Table 23. continued.

Home Port	Area Landed	Area Fished	Pounds Landed	Total Landings in States	% of Total Pounds
August 1-31					
LA	LA	LA	4.84	6.77	72.7
TX	LA	LA	0.40	6.77	6.0
Other	LA	LA	0.77	6.77	11.5
Unknown	LA	LA	0.50	6.77	7.6
LA	LA	TX	0.01	6.77	0.2
TX	LA	TX	0.00	6.77	0.0
Other	LA	TX	0.00	6.77	0.0
Unknown	LA	TX	0.00	6.77	0.0
LA	TX	LA	0.18	7.47	2.4
TX	TX	LA	1.28	7.47	17.1
Other	TX	LA	0.24	7.47	3.2
Unknown	TX	LA	0.19	7.47	2.5
LA	TX	TX	0.15	7.47	2.0
TX	TX	TX	4.26	7.47	57.1
Other	TX	TX	0.79	7.47	10.6
Unknown	TX	TX	0.37	7.47	5.0

\*Home port vessels from other states (i.e., Florida, Mississippi and Alabama).

\*\*Unknown consolidated vessels and boats, mostly inshore boats.

Table 24. Summary of fishing effort and CPUE for Louisiana (13-17) and Texas (18-21).

Fishing Effort (1000 Day)						
Year	Areas 13-17			Areas 18-21		
	May-June	July	August	May-June	July	August
1981	14.8	8.1	3.8	1.1	4.4	10.4
1982	14.2	6.4	3.4	2.6	5.2	10.2
1983	9.1	4.2	4.9	2.3	3.7	6.7
1984	9.8	6.4	4.7	2.4	8.2	9.0
1985	11.1	6.0	3.7	1.5	6.8	8.4
1986	15.9	7.5	4.3	6.3	6.3	6.2
Average (81-86)	11.8	6.2	4.1	2.0	5.7	8.9

CPUE (lbs/fishing day)						
Year	Areas 13-17			Areas 18-21		
	May-June	July	August	May-June	July	August
1981	852	927	799	308	2,382	1,408
1982	607	525	522	295	1,279	629
1983	430	415	470	310	1,414	714
1984	718	598	573	295	1,074	723
1985	982	612	682	389	1,223	672
1986	830	840	773	524	896	799

Table 25. Average price per pound (in dollars) for >67 count and 41-50 count shrimp.

	May	June	July	August
>67 count shrimp/price per pound				
1985	.71	1.01	1.46	2.01
1986	.97	1.32	1.63	1.69
41-50 count price per pound				
1985	2.60	2.25	2.37	2.48
1986	3.61	3.44	3.41	3.59

Table 26. Percent of 1981-1986 SEAMAP stations (statistical subareas 18-21) with mean shrimp lengths >68 count (112 mm) at various nautical miles distances from shore.

Distance	Frequency	Percent	Cumulative %
0-5	81	45.5	45.5
6-10	47	26.4	71.9
11-15	12	6.7	78.7
16-20	13	7.3	86.0
21-25	18	10.1	96.1
26-30	5	2.8	98.9
31-35	1	0.6	99.4
36-40	1	0.6	100.0
41-45	0	0.0	100.0
46-50	0	0.0	100.0
>50	0	0.0	100.0

Table 27. Percent of shrimp collected from 1981-1986 SEAMAP samples (statistical subareas 18-21) with lengths >68 count (112 mm) at various nautical mile distances from shore.

Distance	Frequency	Percent	Cumulative %
0-5	8,022	33.3	33.3
6-10	7,071	29.4	62.7
11-15	2,910	12.1	74.8
16-20	2,077	8.6	83.4
21-25	2,570	10.7	94.1
26-30	570	2.4	96.5
31-35	459	1.9	99.4
36-40	195	0.8	99.2
41-45	106	0.4	99.7
46-50	1	0.0	99.7
>50	83	0.3	100.0

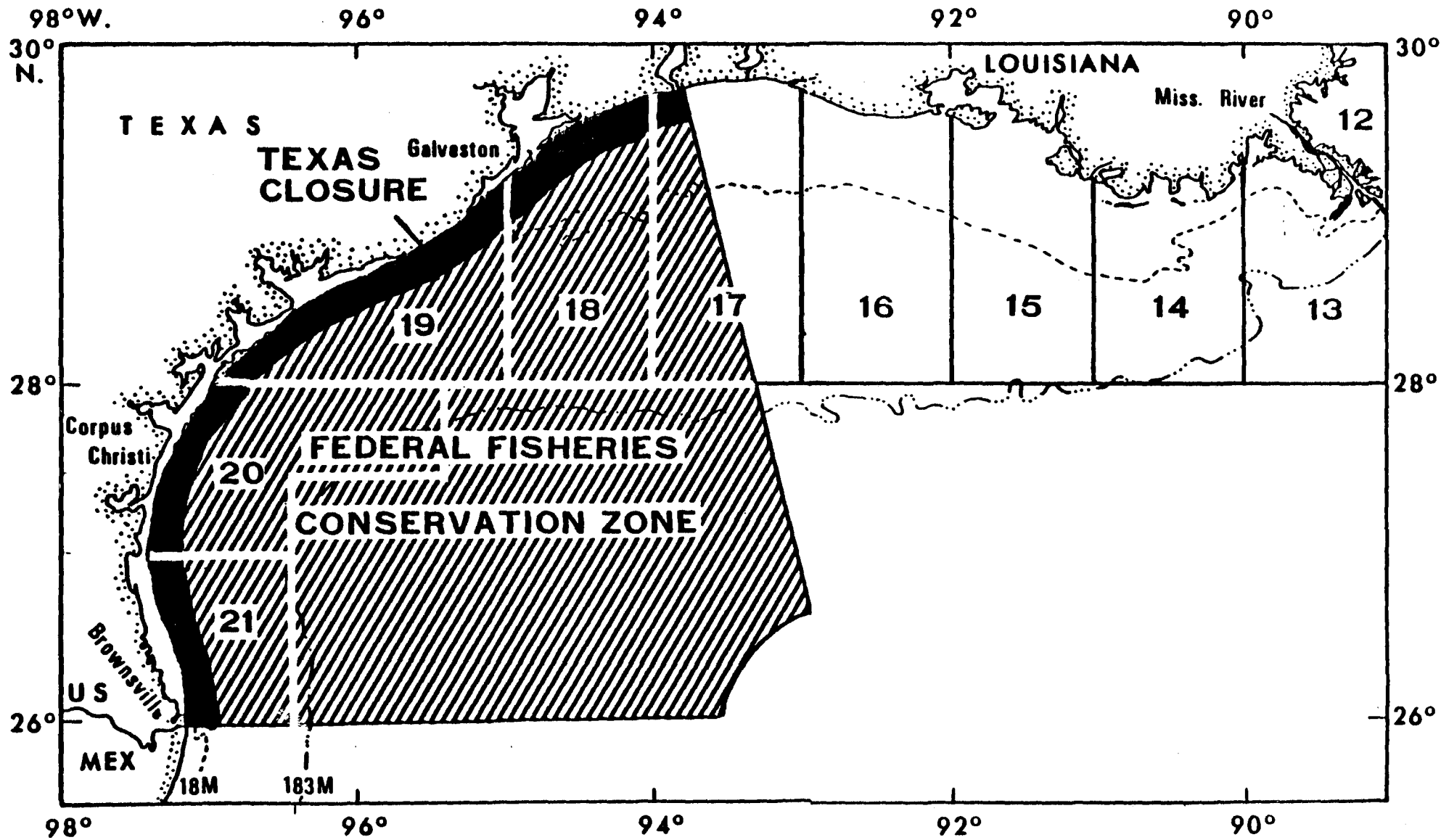

Figure 1. Location of statistical subareas and the Federal FCZ.

## INSHORE BROWN SHRIMP SUBAREAS 13-17

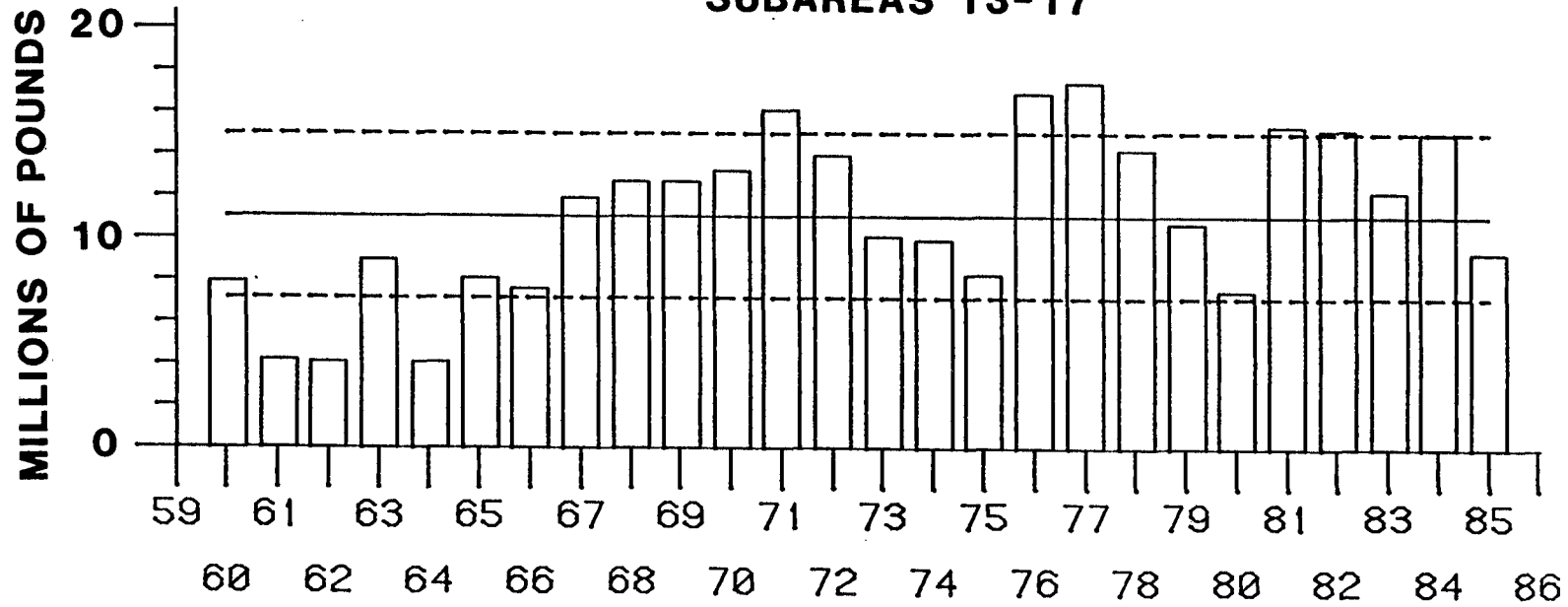

Figure 2. Annual inshore brown shrimp landings in Louisiana west of the Mississippi River (solid line is average 1960-1985 and broken line is standard deviation).

### OFFSHORE BROWN SHRIMP SUBAREAS 13-17

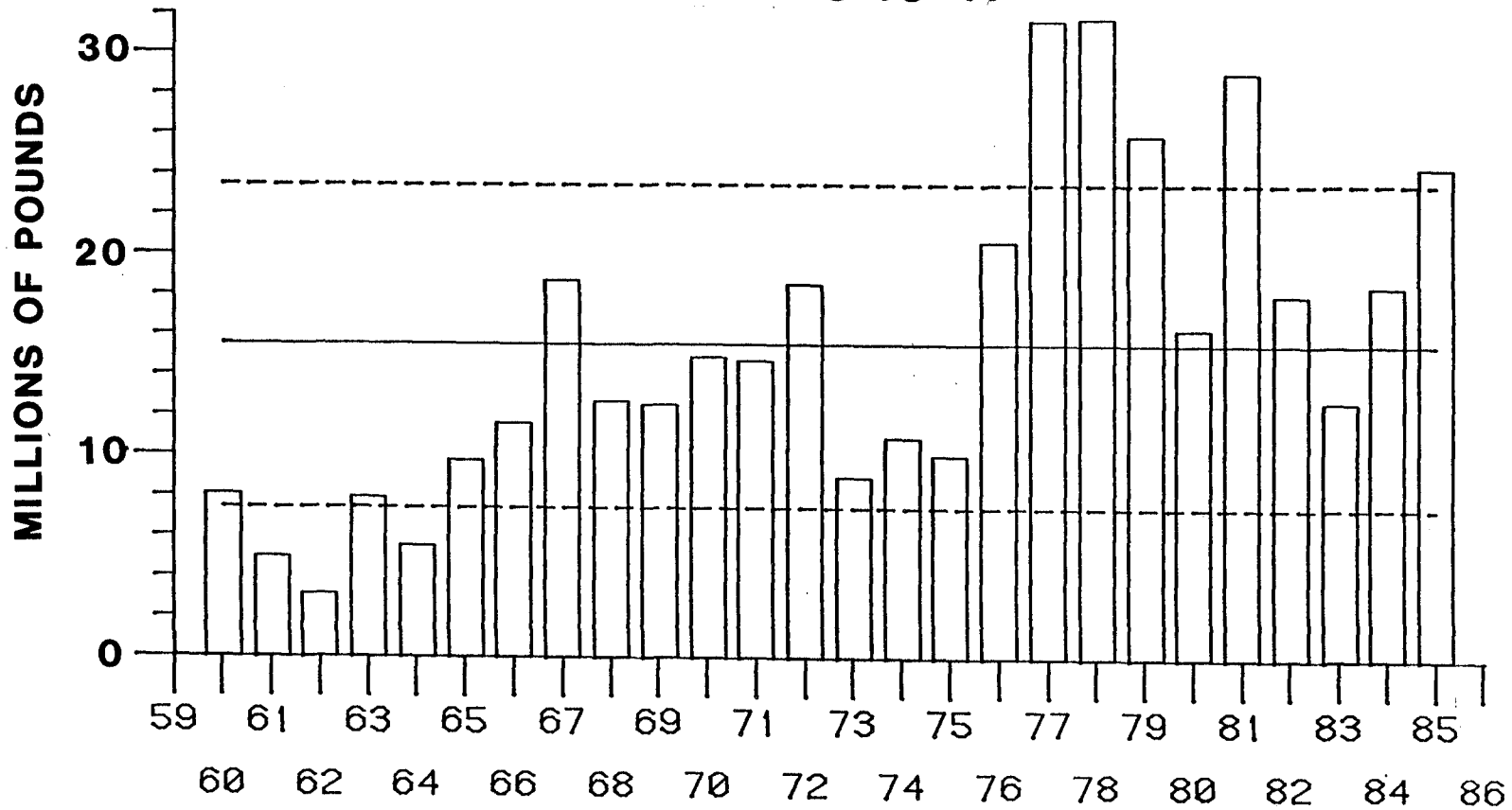

Figure 3. Annual offshore brown shrimp landings from statistical subareas 13-17 (solid line is average 1960-1985 and broken line is standard deviation).

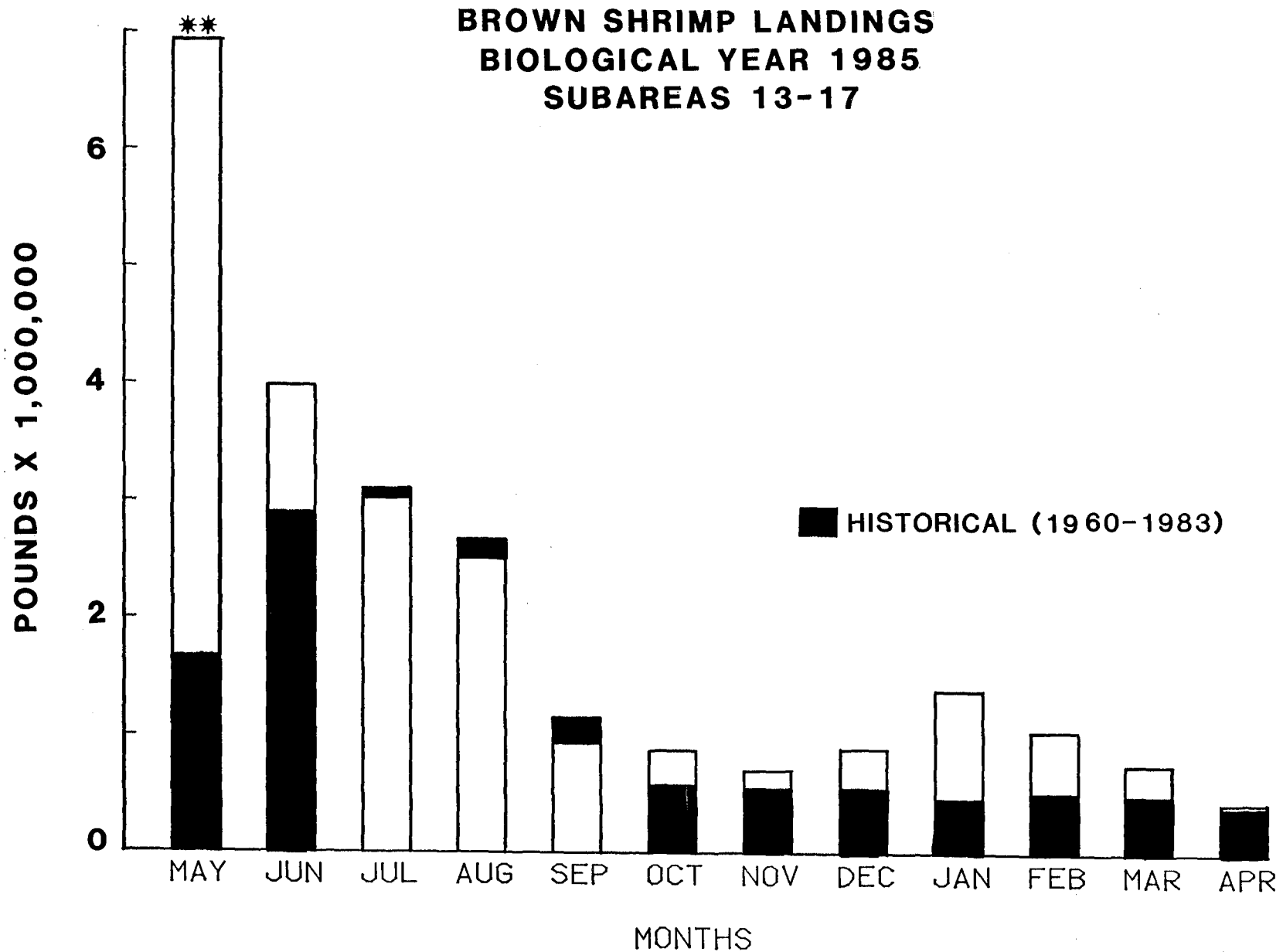

Figure 4. Average monthly historical catch compared to monthly catch values during biological year 1985.

**BROWN SHRIMP EFFORT  
BIOLOGICAL YEAR 1985  
SUBAREAS 13-17**

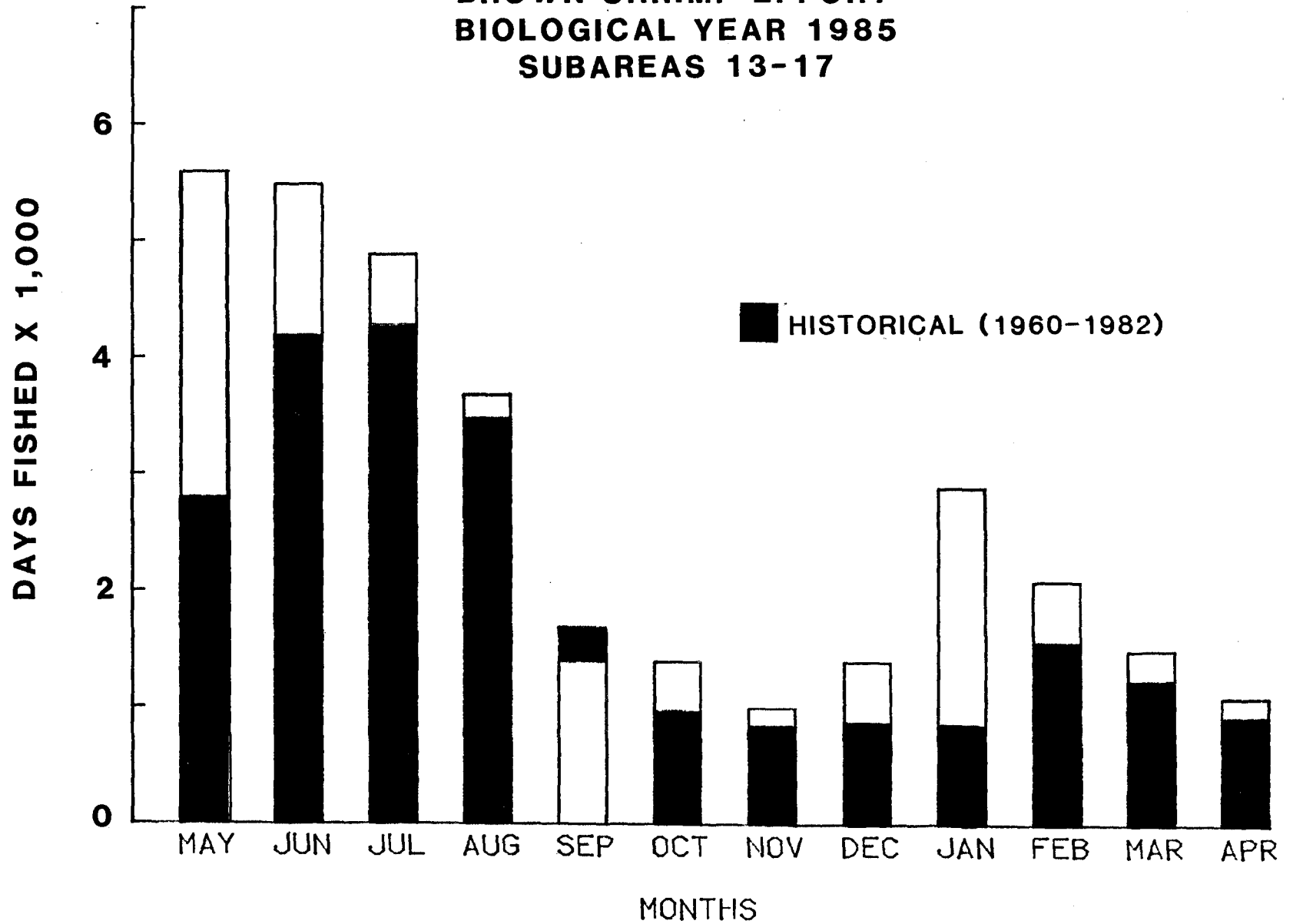

Figure 5. Average monthly historical effort compared to monthly effort values during biological year 1985.

**OFFSHORE BROWN SHRIMP LANDINGS  
BIOLOGICAL YEAR 1985  
SUBAREAS 13-17**

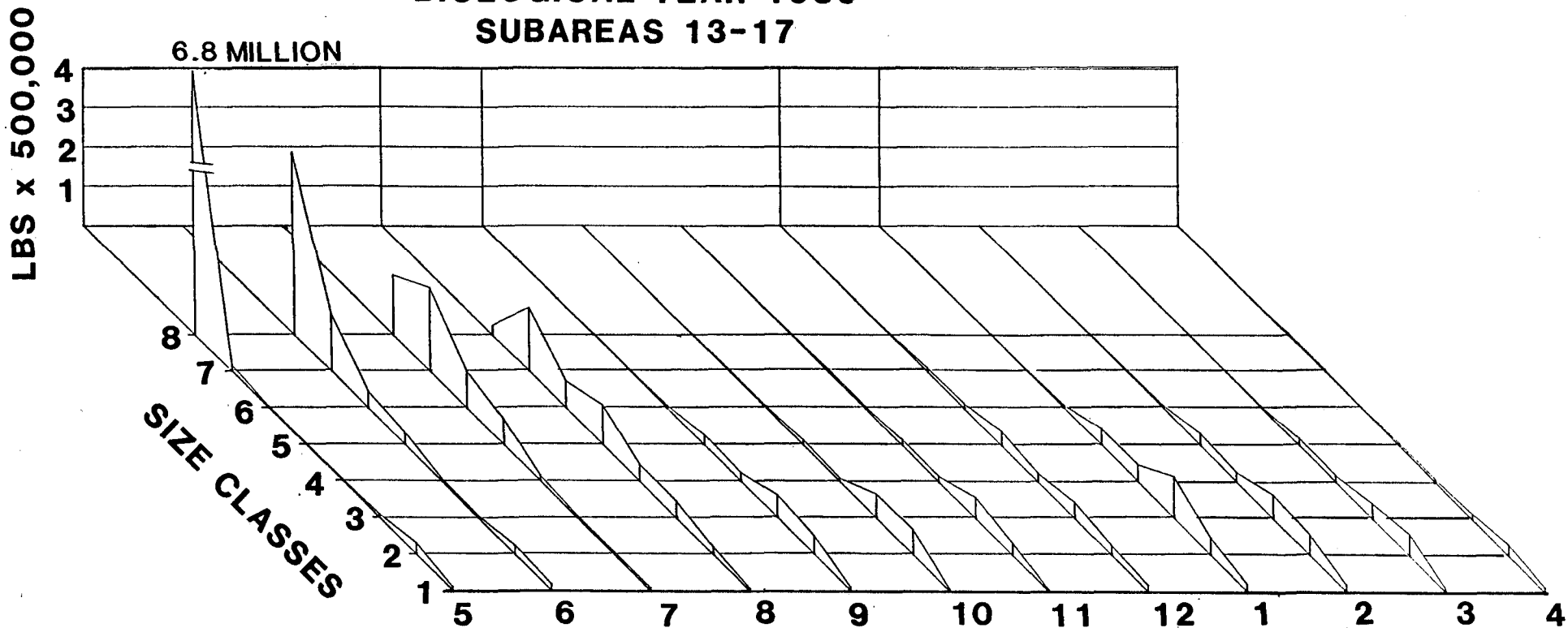

Figure 6. Total monthly catch by size classes for May 1985-April 1986.  
 Size classes in count are: 1 = less than 15, 2 = 15-20,  
 3 = 21-25, 4 = 26-30, 5 = 31-40, 6 = 41-50, 7 = 51-67 and  
 8 = greater than or equal to 68.

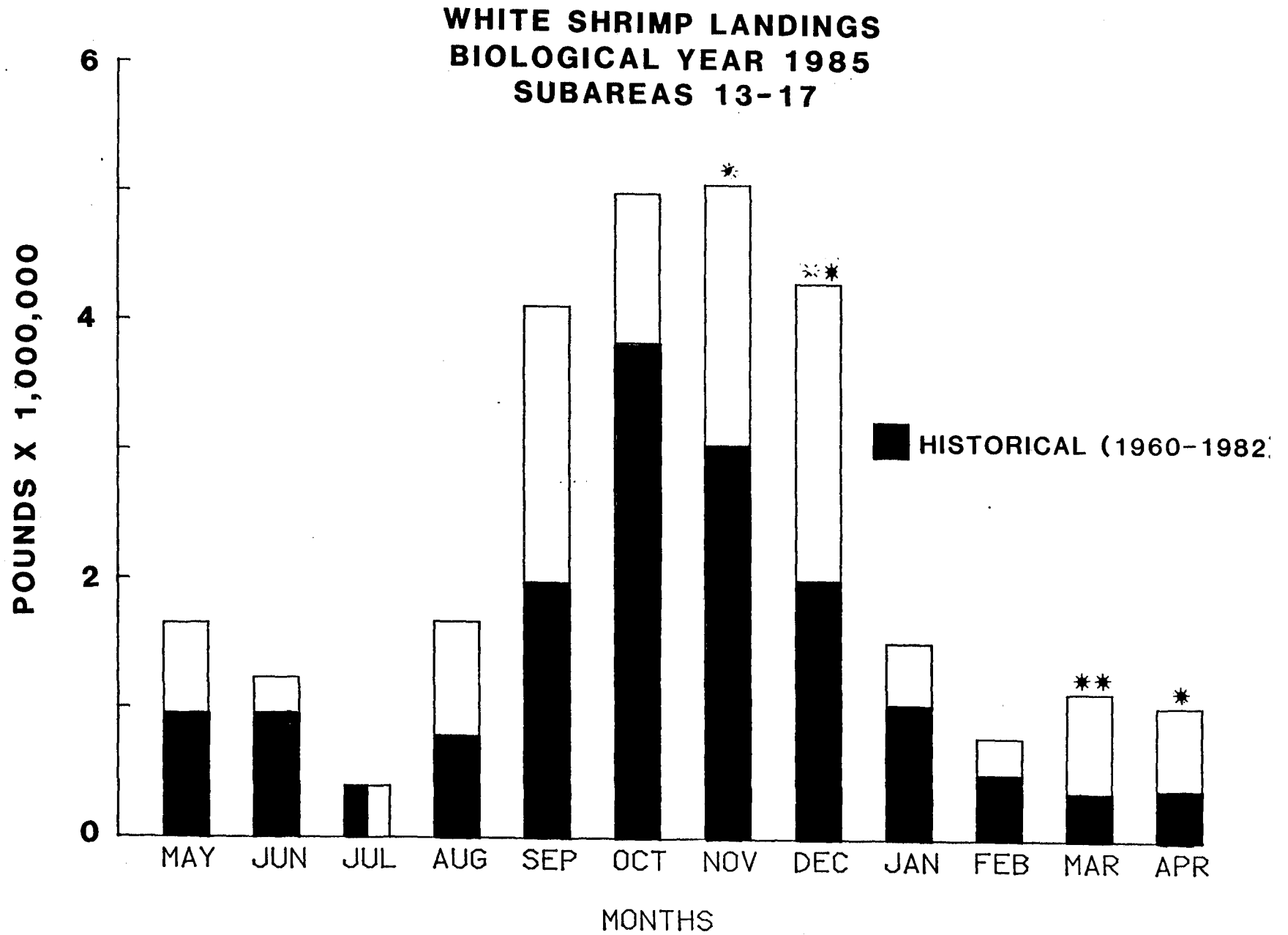

Figure 7. Average monthly historical catch compared to monthly catch values during biological year 1985.

**WHITE SHRIMP EFFORT  
BIOLOGICAL YEAR 1985  
SUBAREAS 13-17**

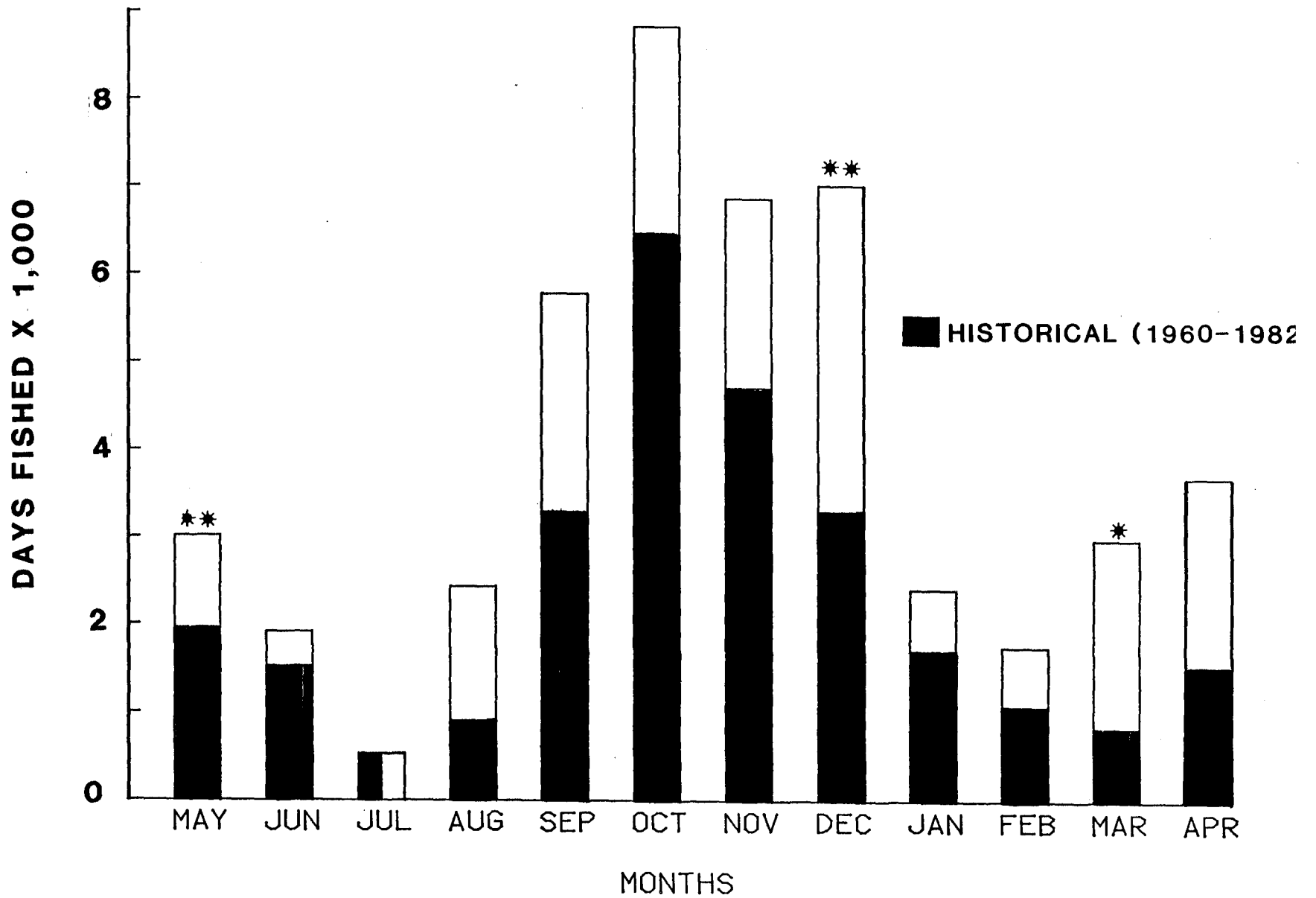

Figure 8. Average monthly historical effort compared to monthly effort values during biological year 1985.

MILLIONS OF POUNDS

### INSHORE BROWN SHRIMP SUBAREAS 18-21

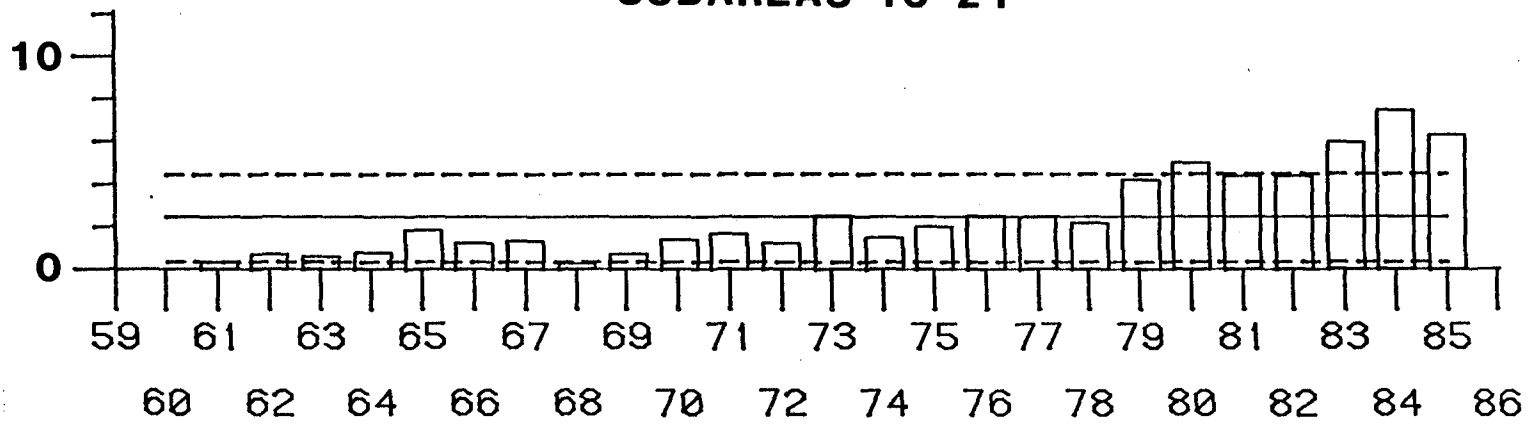

Figure 9. Annual inshore brown shrimp landings in Texas (solid line is average 1960-1985 and broken line is standard deviation).

## OFFSHORE BROWN SHRIMP SUBAREAS 18-21

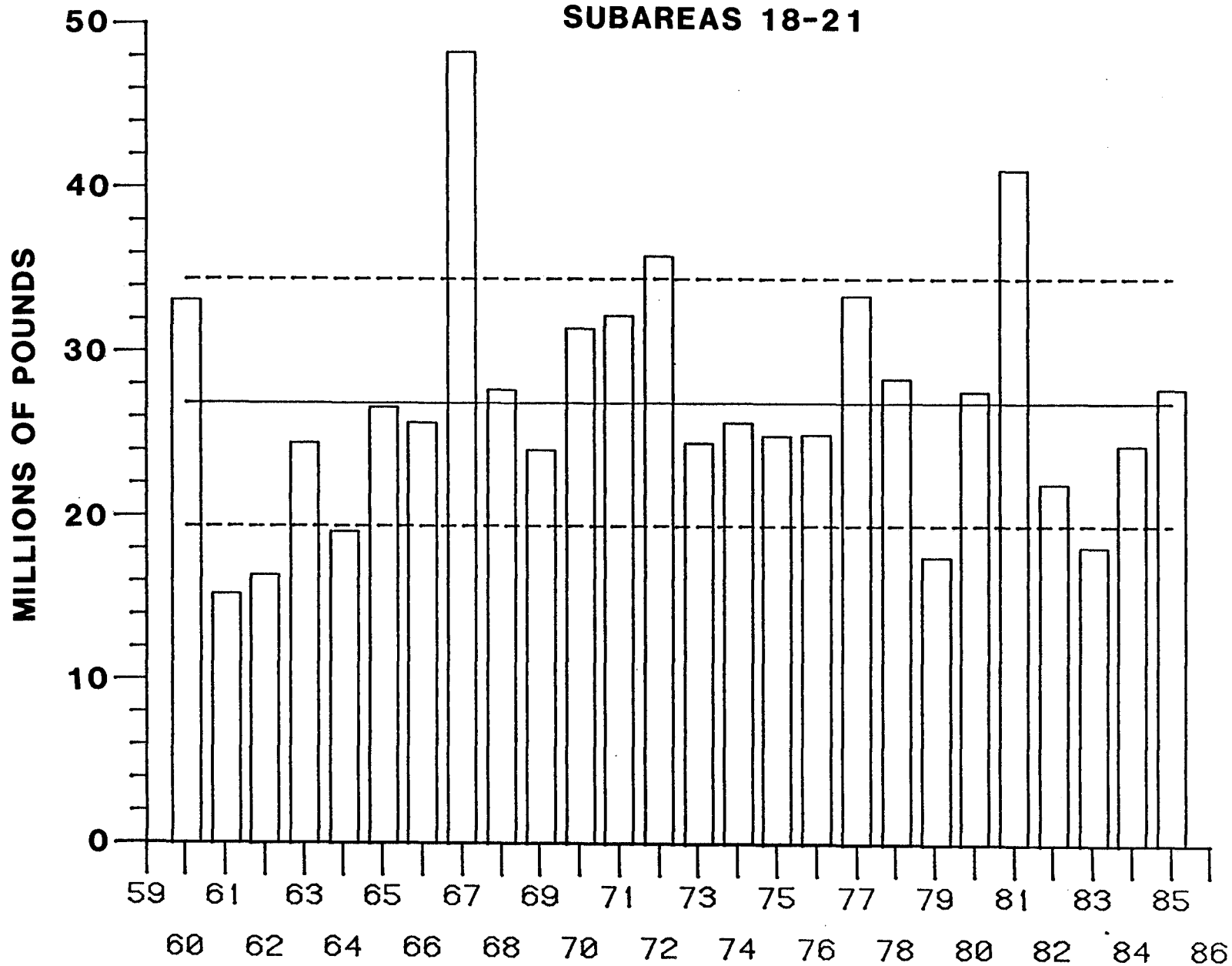

Figure 10. Annual offshore brown shrimp landings in Texas (solid line is average 1960-1985 and broken line is standard deviation).

**BROWN SHRIMP LANDINGS  
BIOLOGICAL YEAR 1985  
SUBAREAS 18-21**

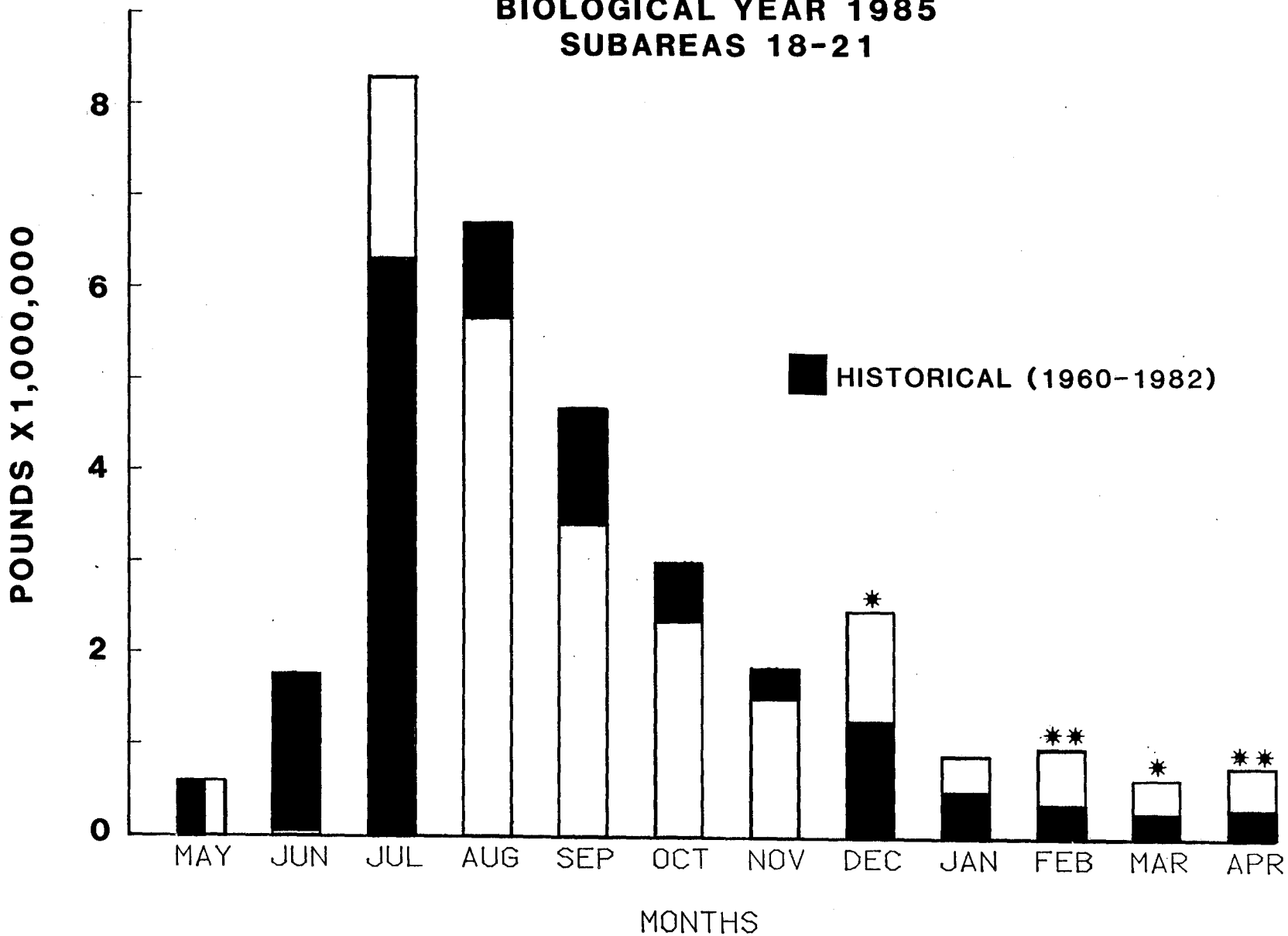

Figure 11. Average monthly historical catch compared to monthly catch values during biological year 1985.

**BROWN SHRIMP EFFORT  
 BIOLOGICAL YEAR 1985  
 SUBAREAS 18-21**

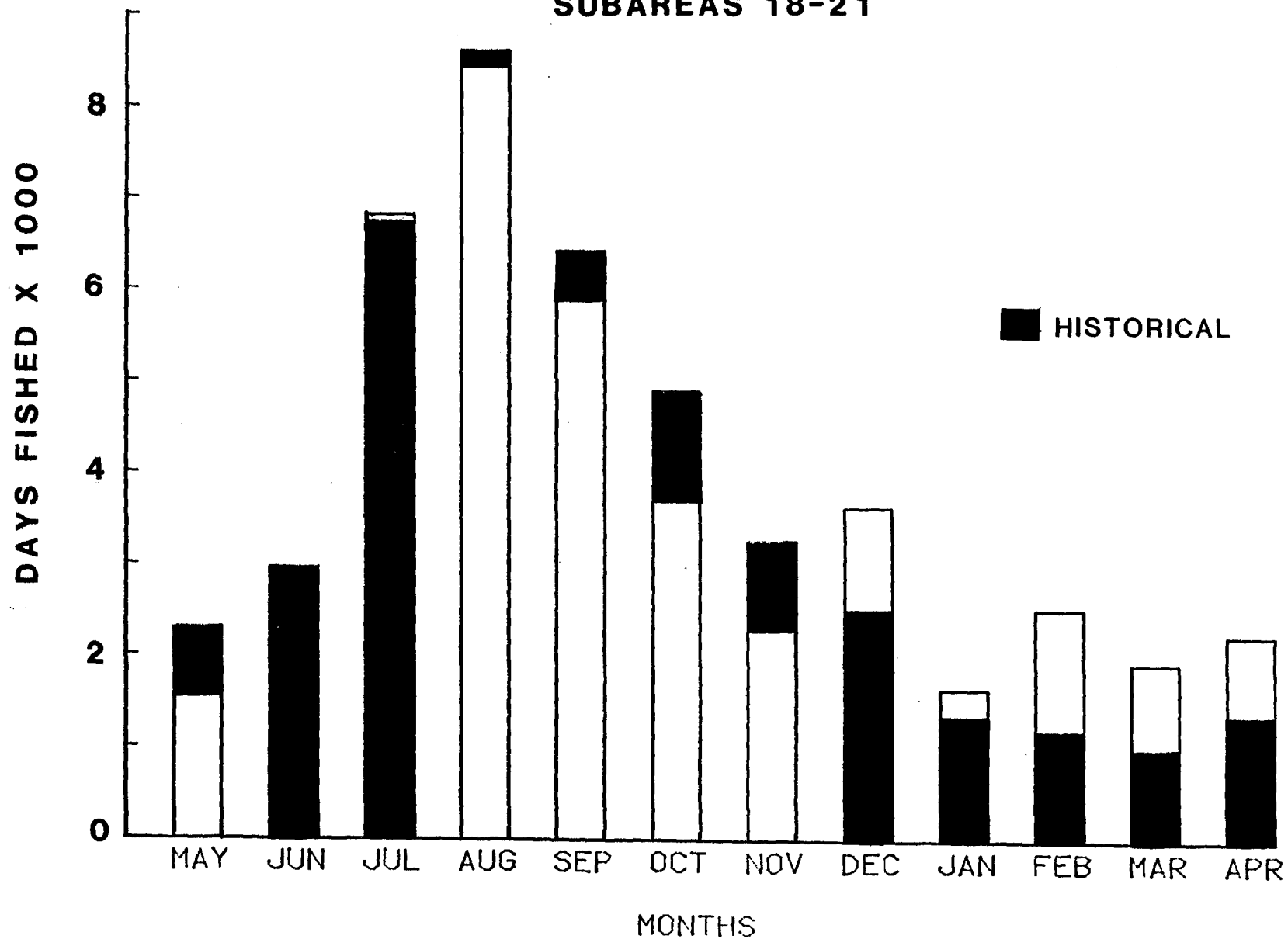

Figure 12. Average monthly historical effort compared to monthly effort values during biological year 1985.

**OFFSHORE BROWN SHRIMP LANDINGS  
BIOLOGICAL YEAR 1985  
SUBAREAS 18-21**

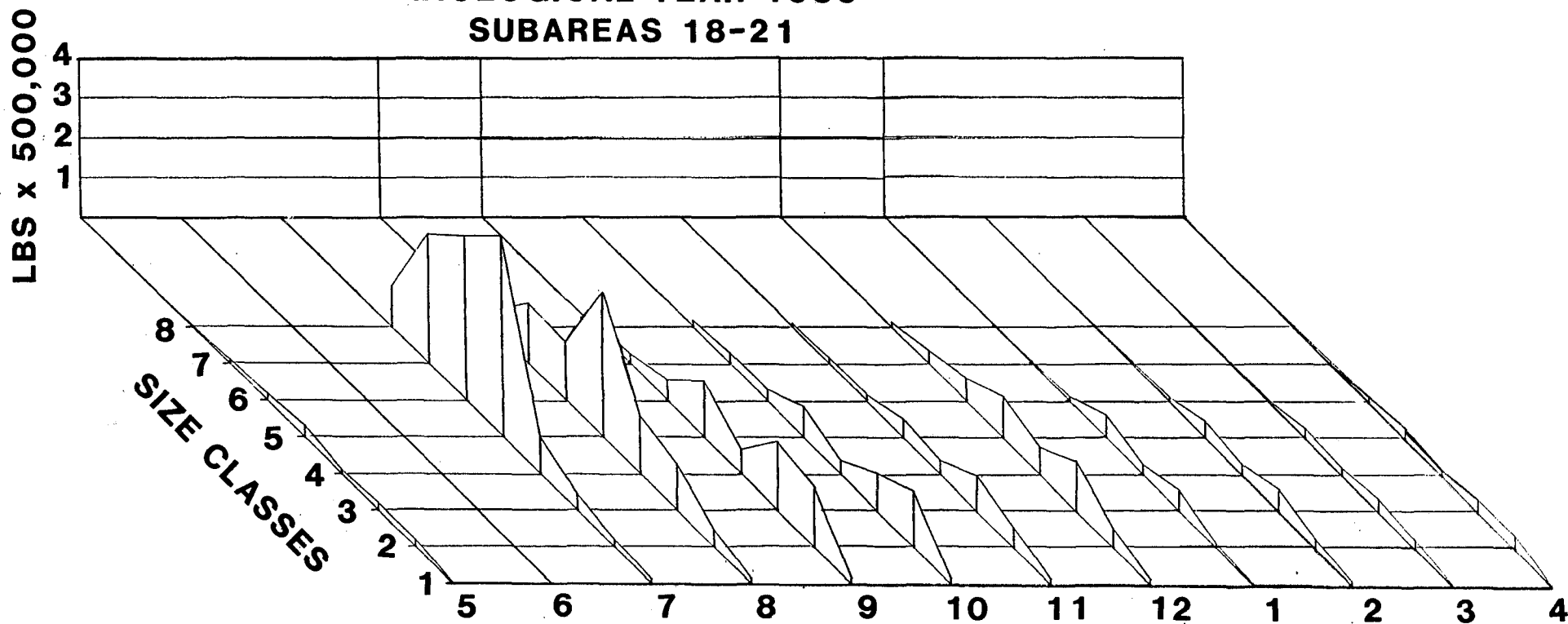

Figure 13. Total monthly catch by size classes for May 1985-April 1986. Size classes in count are: 1 = less than 15, 2 = 15-20, 3 = 21-25, 4 = 26-30, 5 = 31-40, 6 = 41-50, 7 = 51-67 and 8 = greater than or equal to 68.

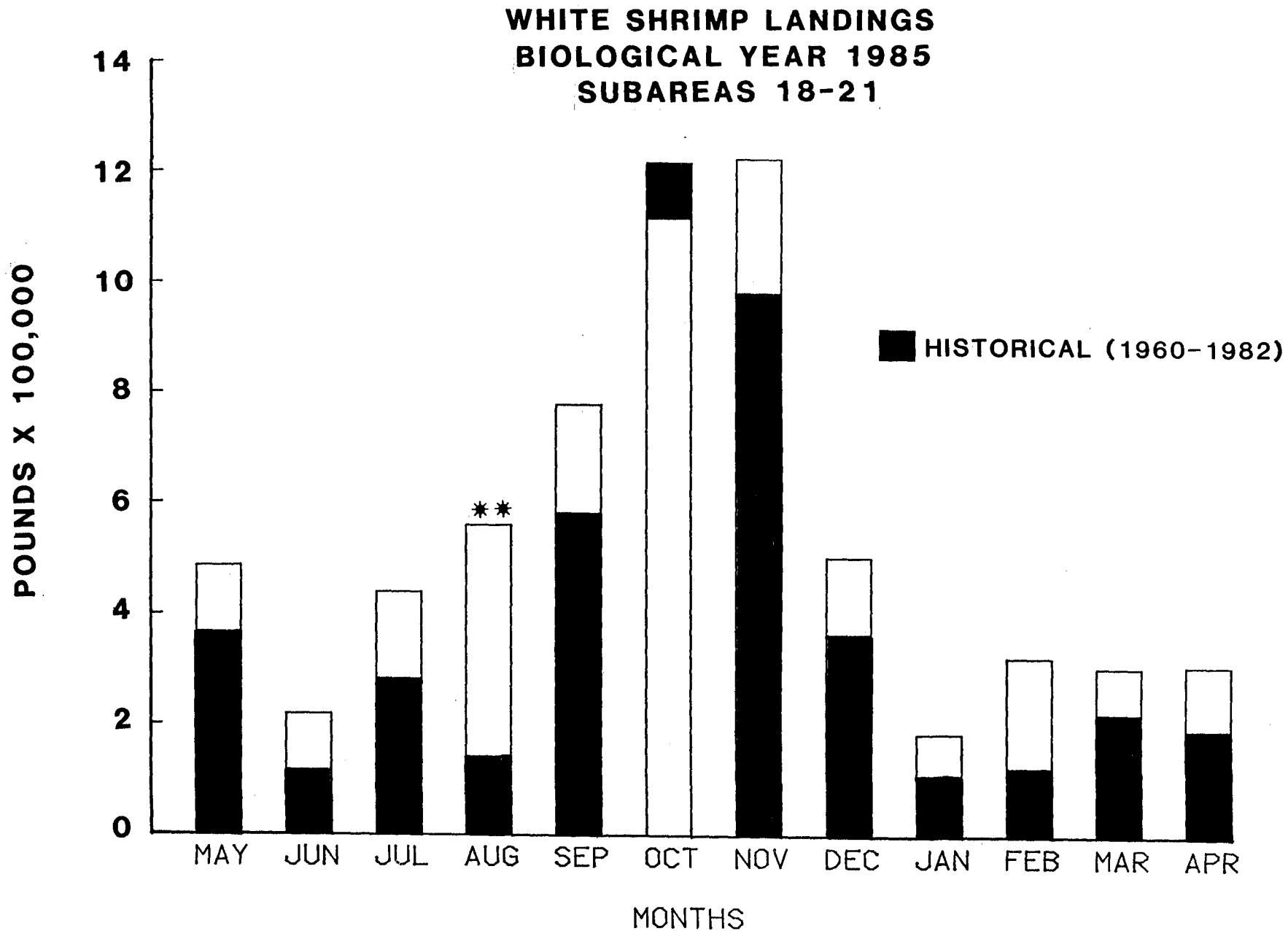

Figure 14. Average monthly historical catch compared to monthly catch values during biological year 1985.

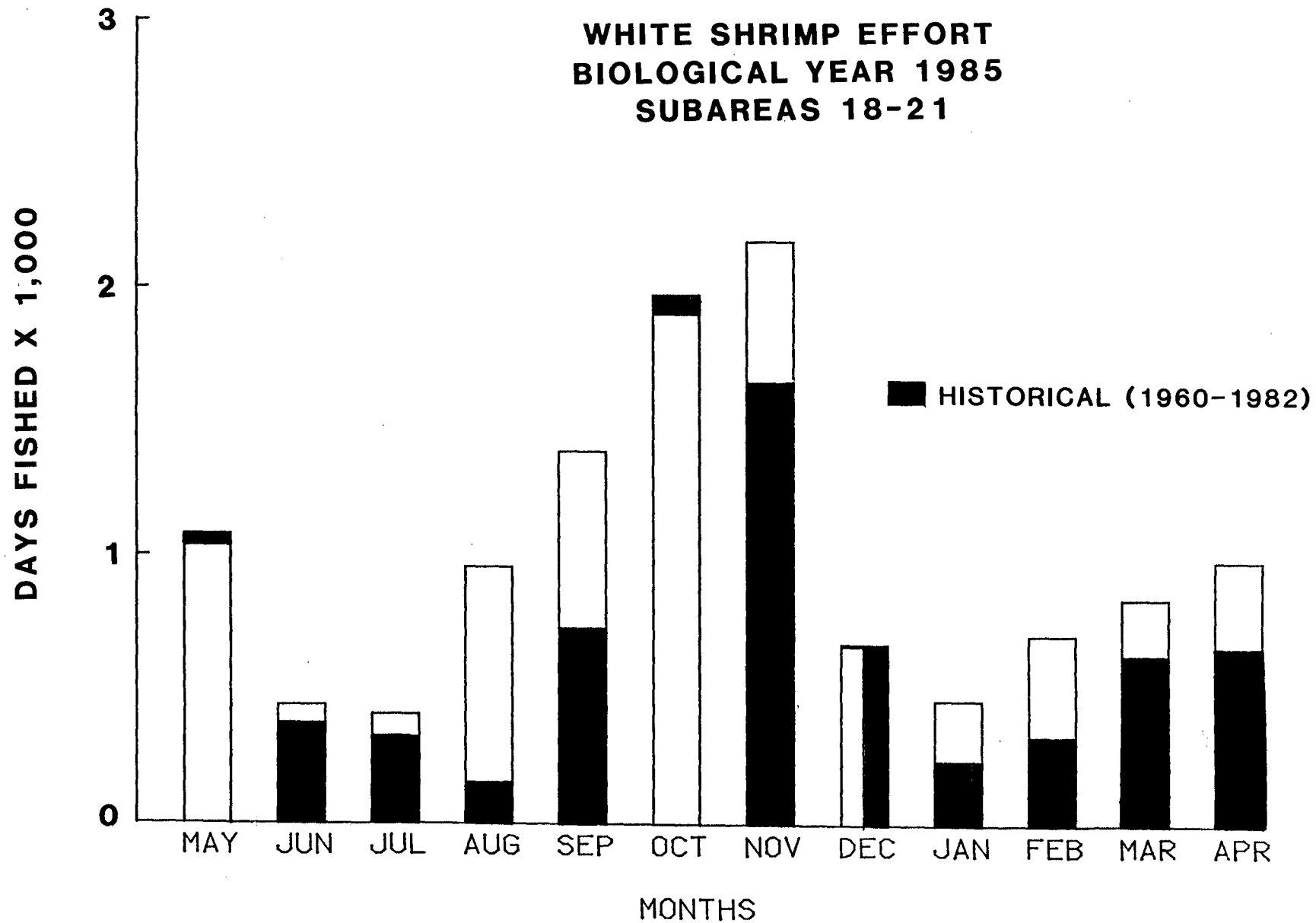

Figure 15. Average monthly historical effort compared to monthly effort values during biological year 1985.

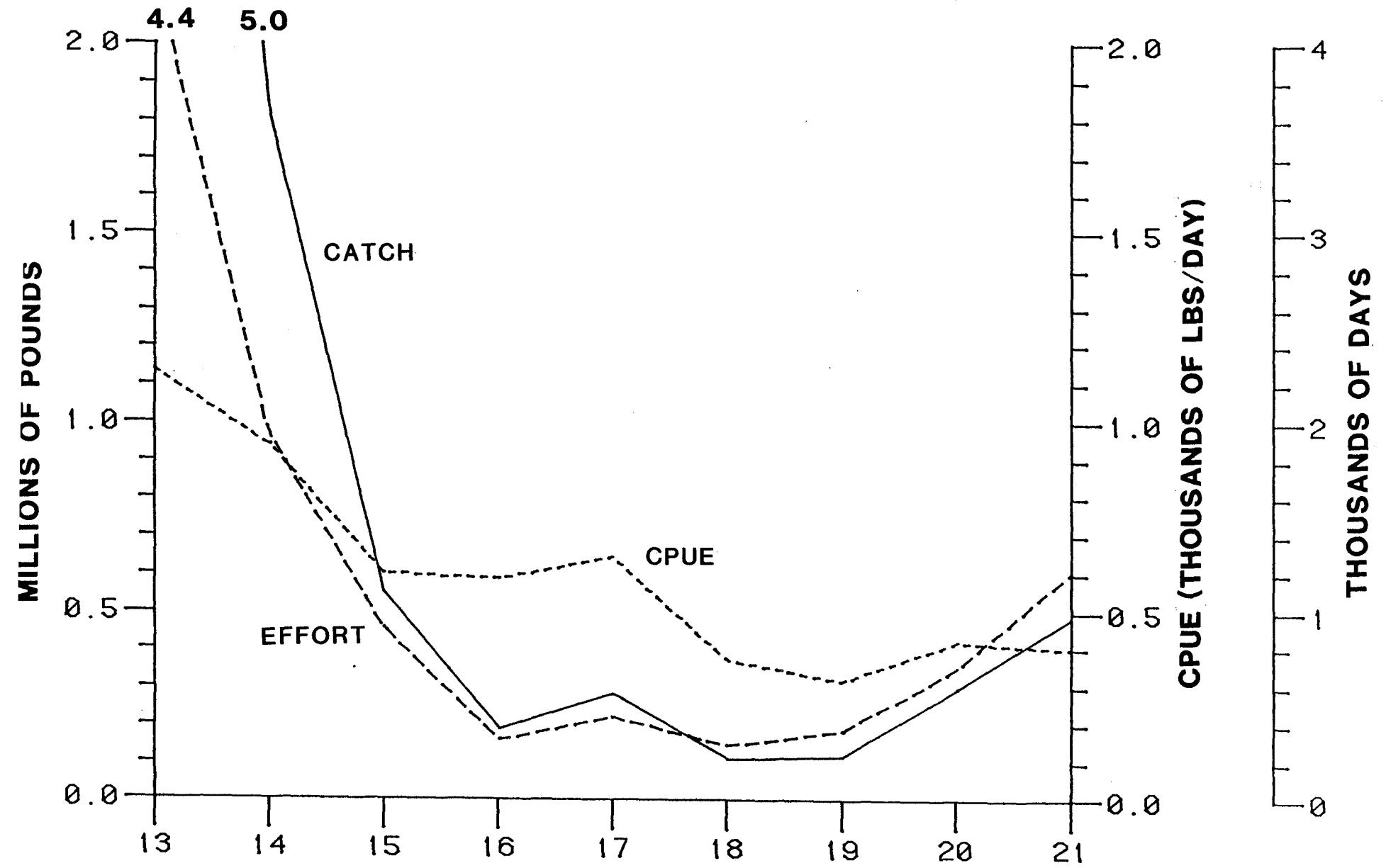

Figure 16. Offshore brown shrimp catch (millions of pounds), fishing effort (days fished) and CPUE (pounds per day) from statistical subareas 13-21 in May 1986.

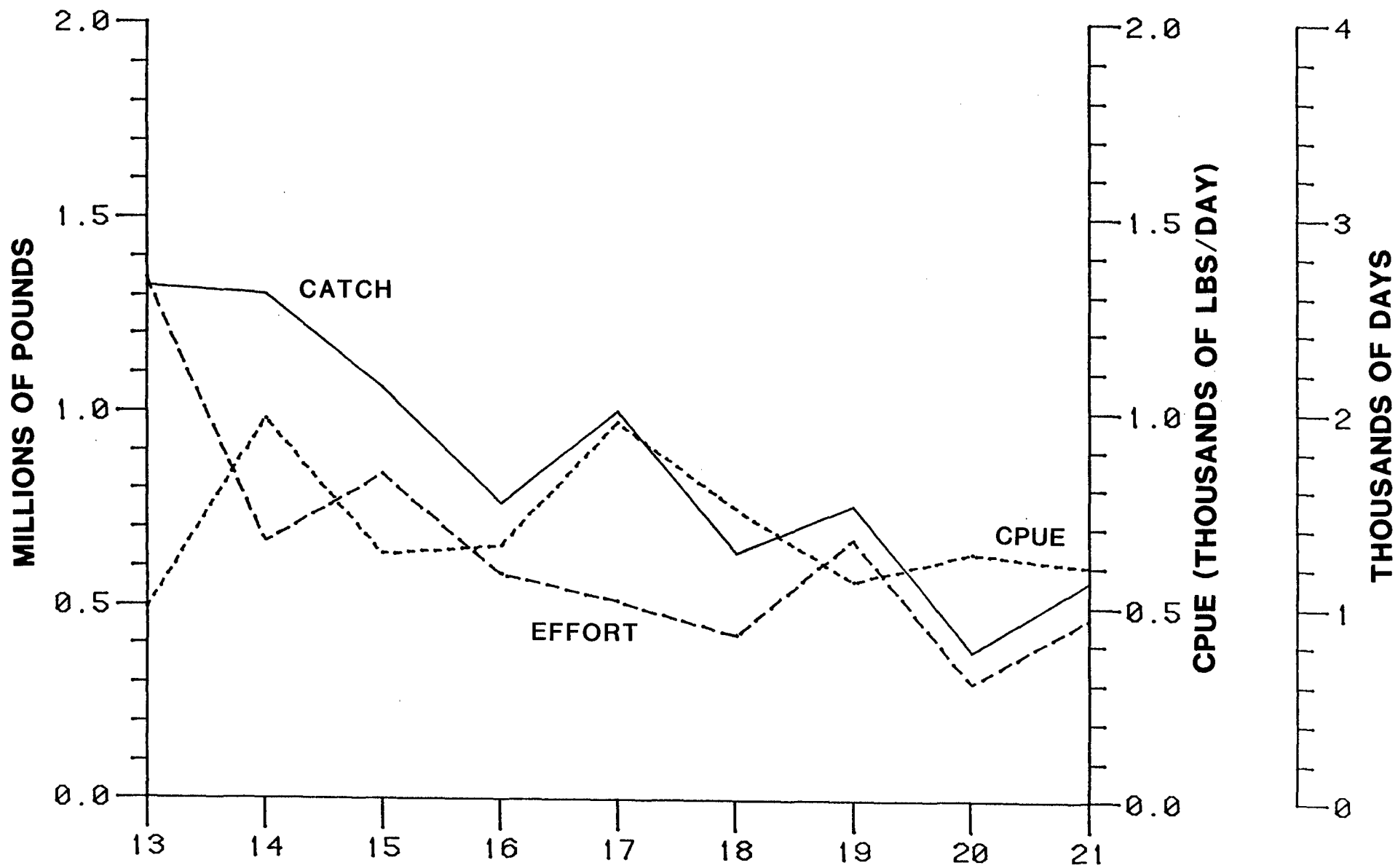

Figure 17. Offshore brown shrimp catch (millions of pounds), fishing effort (days fished) and CPUE (pounds per day) from statistical subareas 13-21 in June 1986.

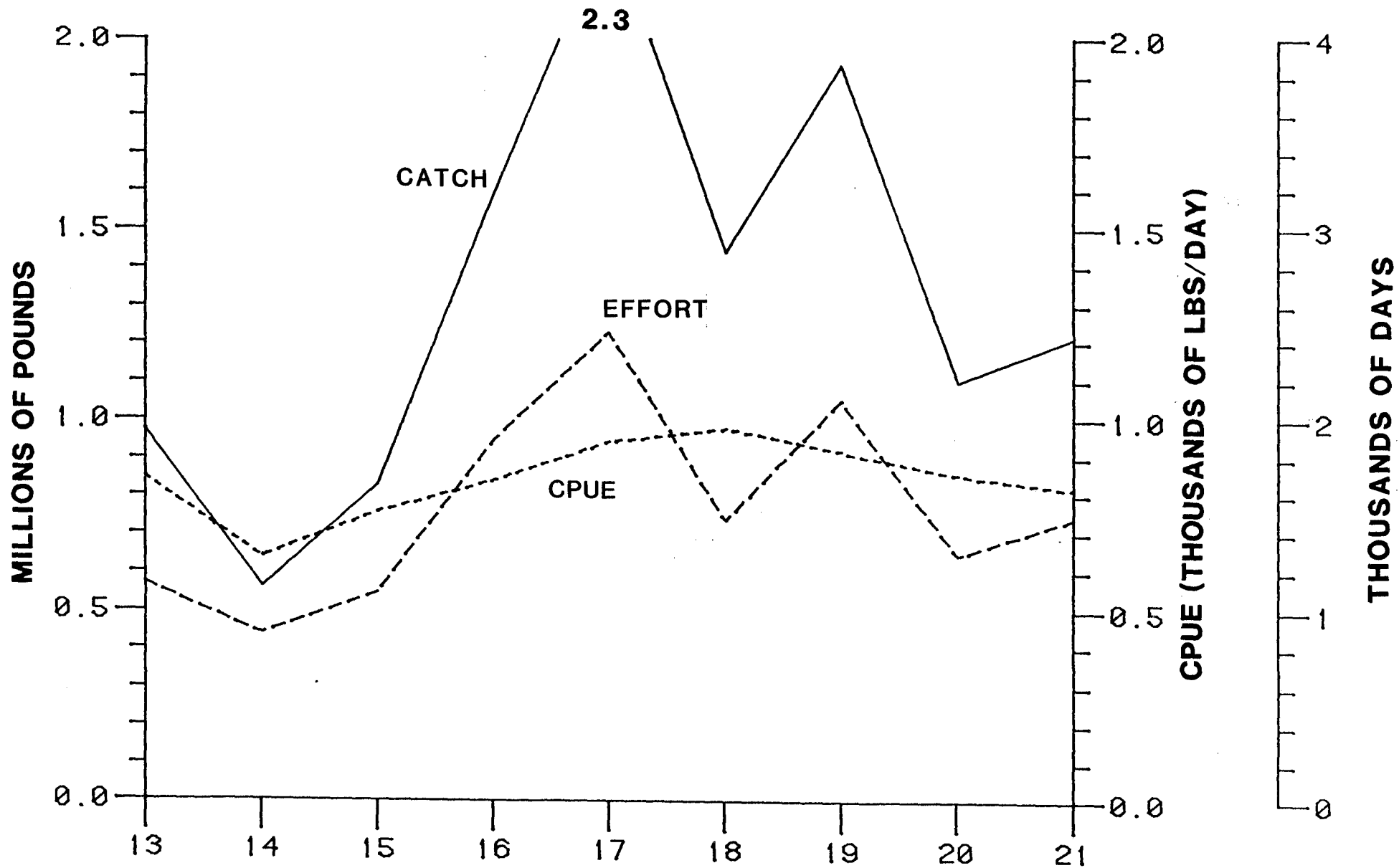

Figure 18. Offshore brown shrimp catch (millions of pounds), fishing effort (days fished) and CPUE (pounds per day) from statistical subareas 13-21 in July 1986.

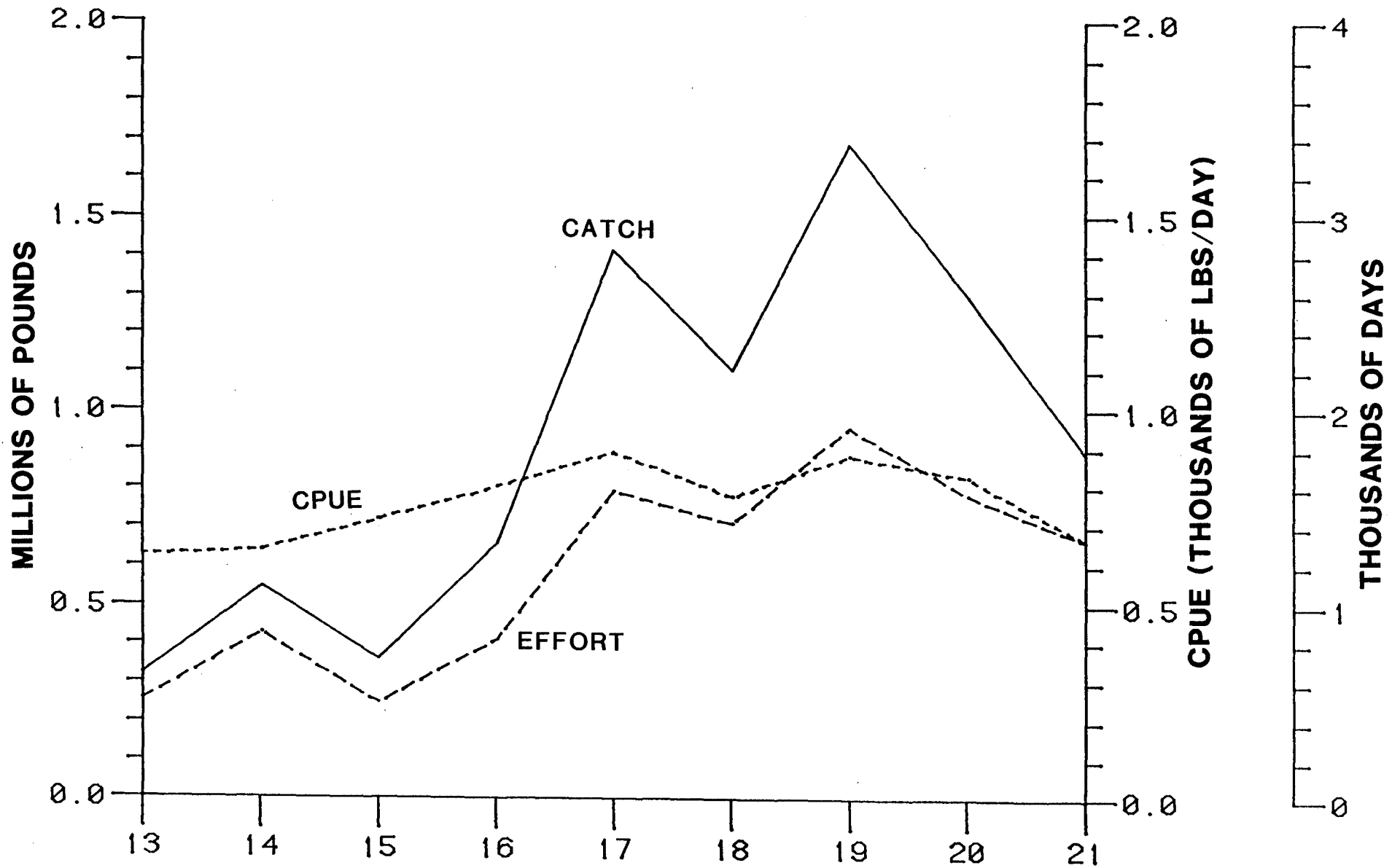

Figure 19. Offshore brown shrimp catch (millions of pounds), fishing effort (days fished) and CPUE (pounds per day) from statistical subareas 13-21 in August 1986.

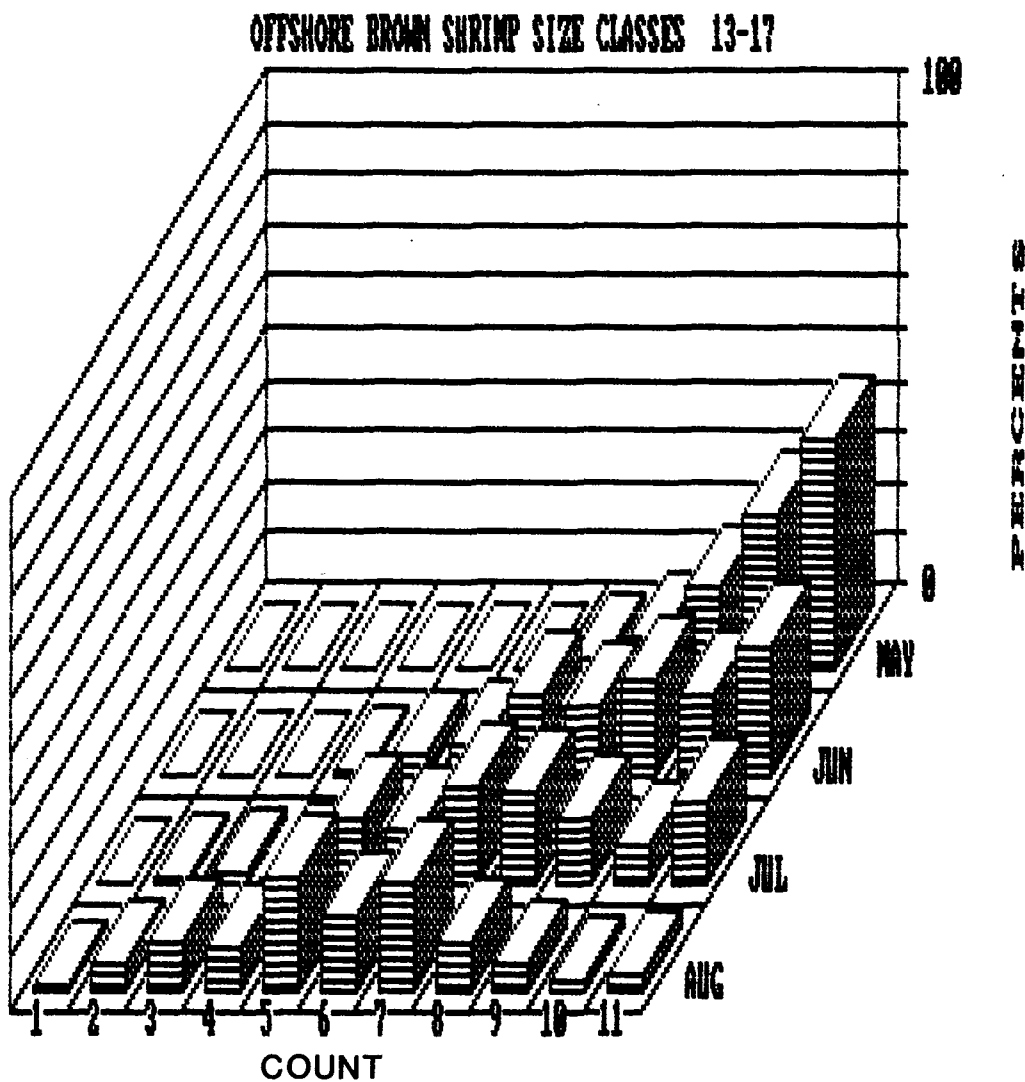

Figure 20. Percent size distribution of brown shrimp caught in statistical subareas 13-17. Size counts are: 1 = less than 15, 2 = 15-20, 3 = 21-25, 4 = 26-30, 5 = 31-40, 6 = 41-50, 7 = 51-67, 8 = 68-80, 9 = 81-100, 10 = 101-115 and 11 = greater than 116.

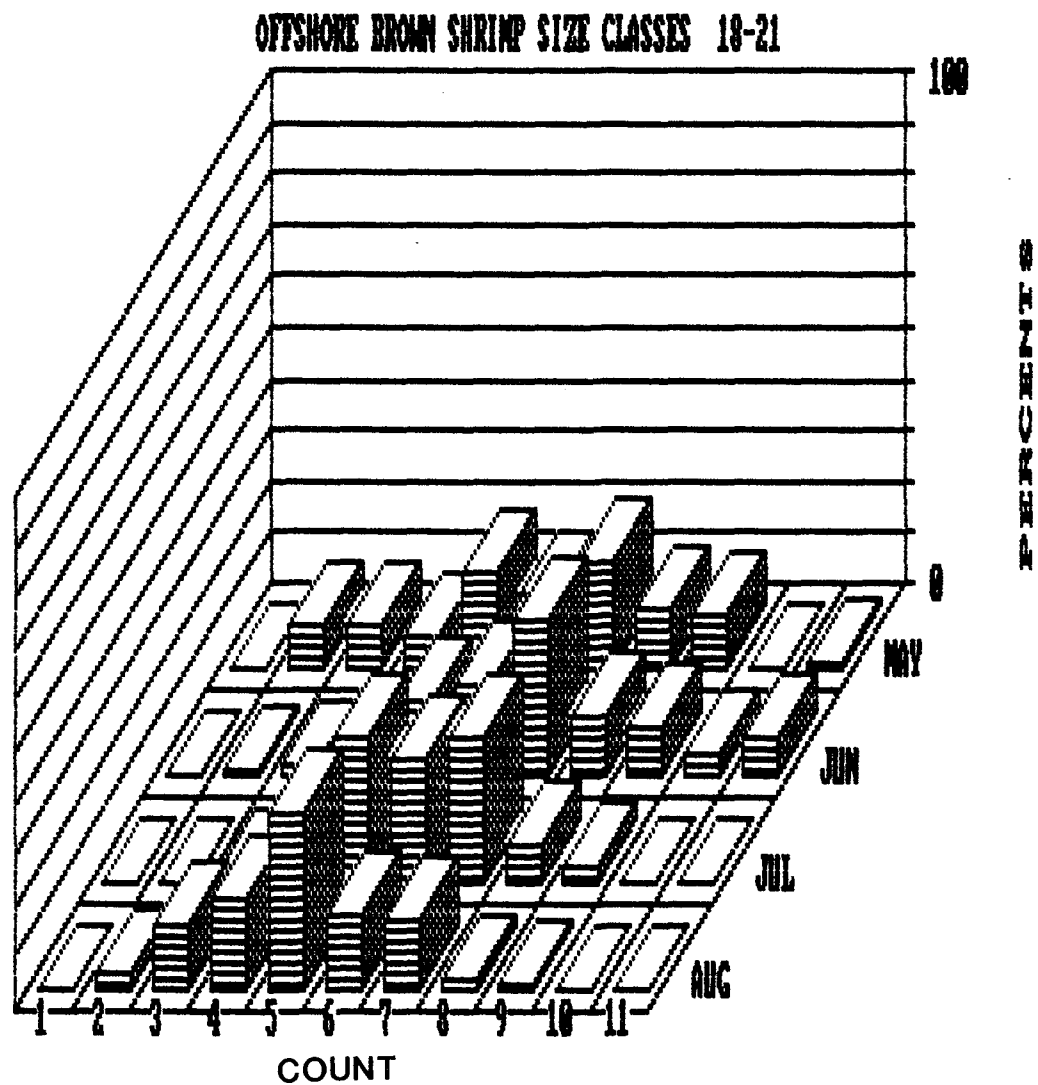

Figure 21. Percent size distribution of brown shrimp caught in statistical subareas 18-21. Size counts are: 1 = less than 15, 2 = 15-20, 3 = 21-25, 4 = 26-30, 5 = 31-40, 6 = 41-50, 7 = 51-67, 8 = 68-80, 9 = 81-100, 10 = 101-115 and 11 = greater than 116.

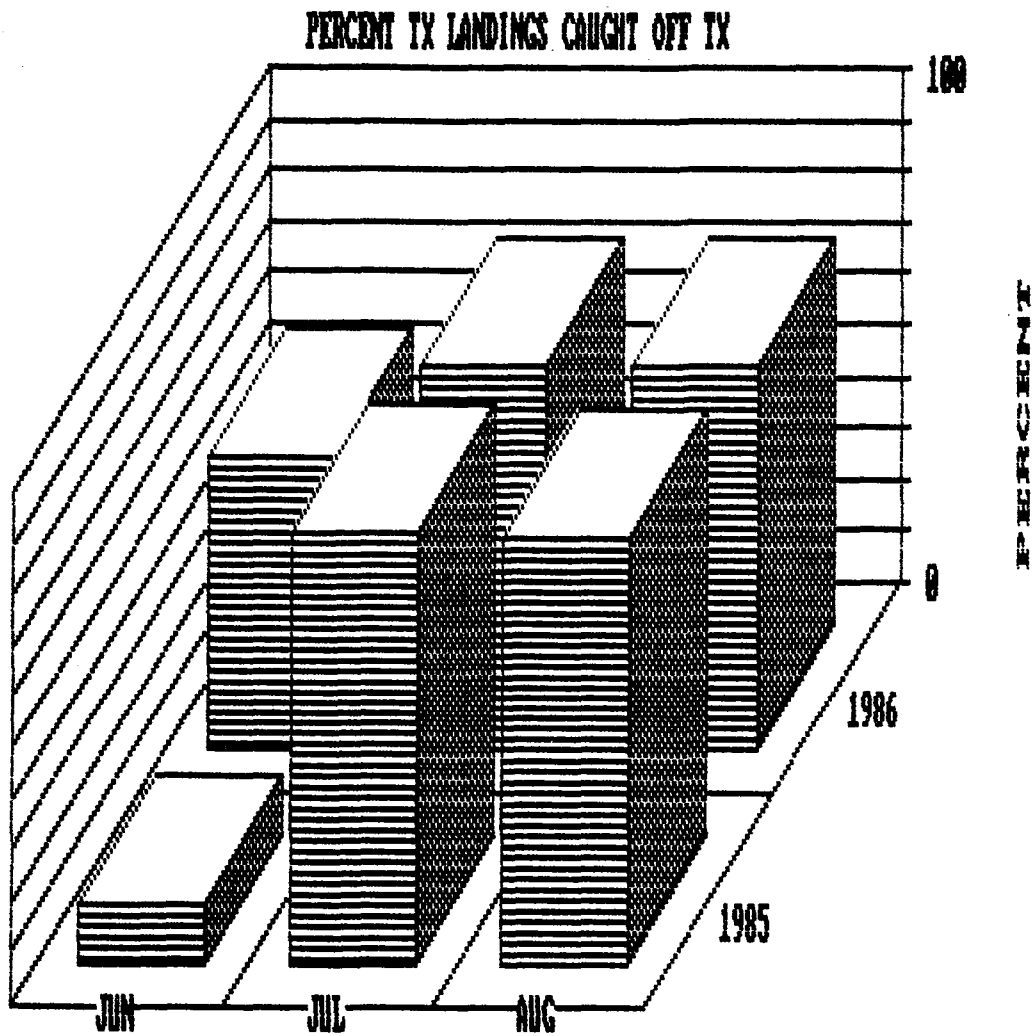

Figure 22. Percentage of offshore brown shrimp landed in Texas and caught off Texas.

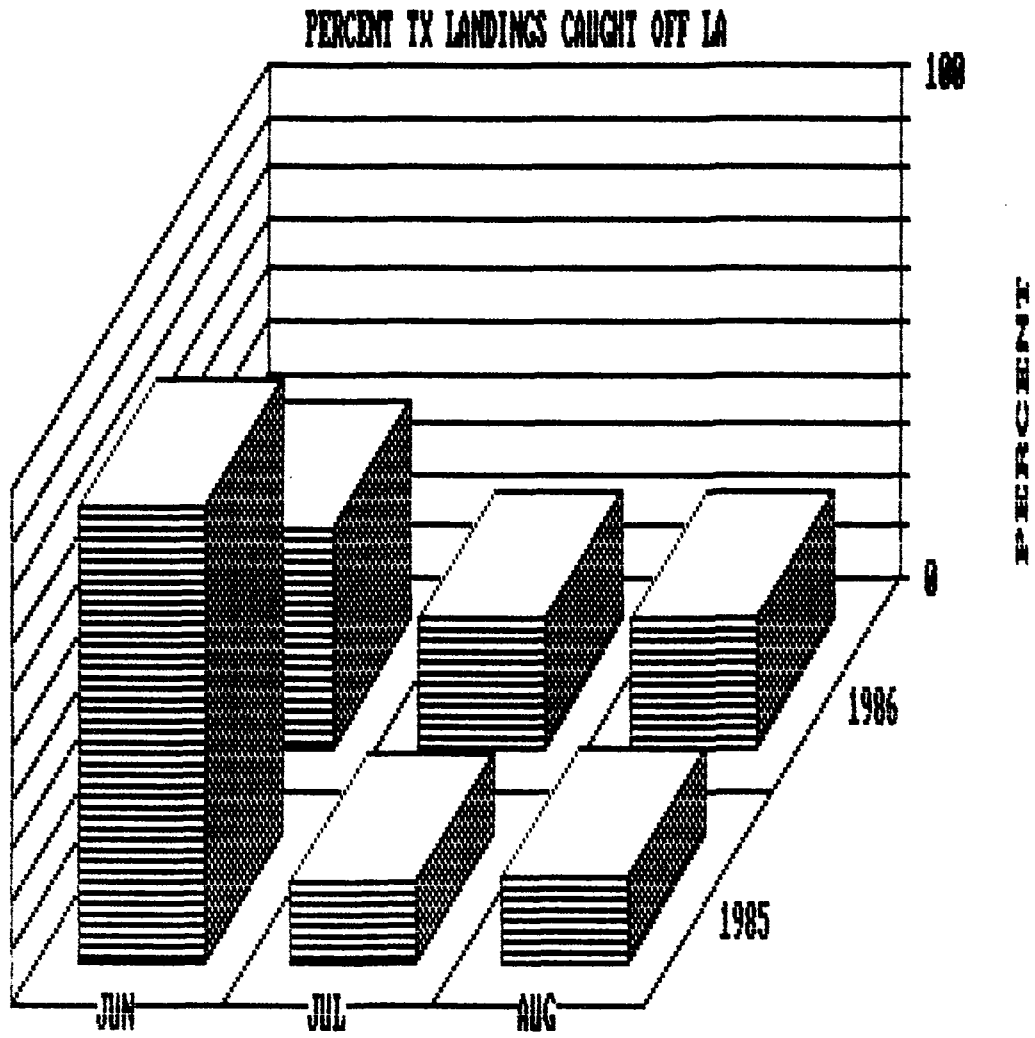

Figure 23. Percentage of offshore brown shrimp landed in Texas, but caught off Louisiana.

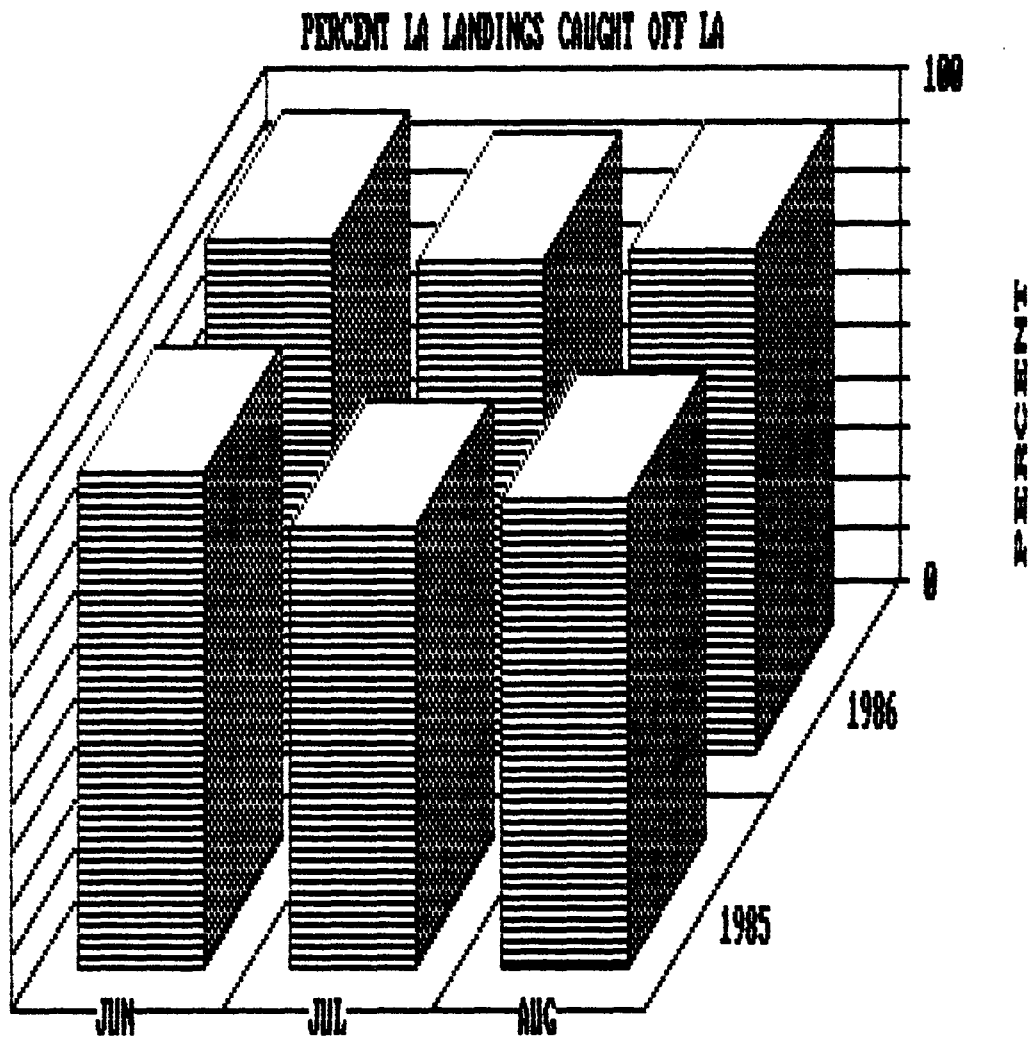

Figure 24. Percentage of offshore brown shrimp landed in Louisiana, and caught off Louisiana.

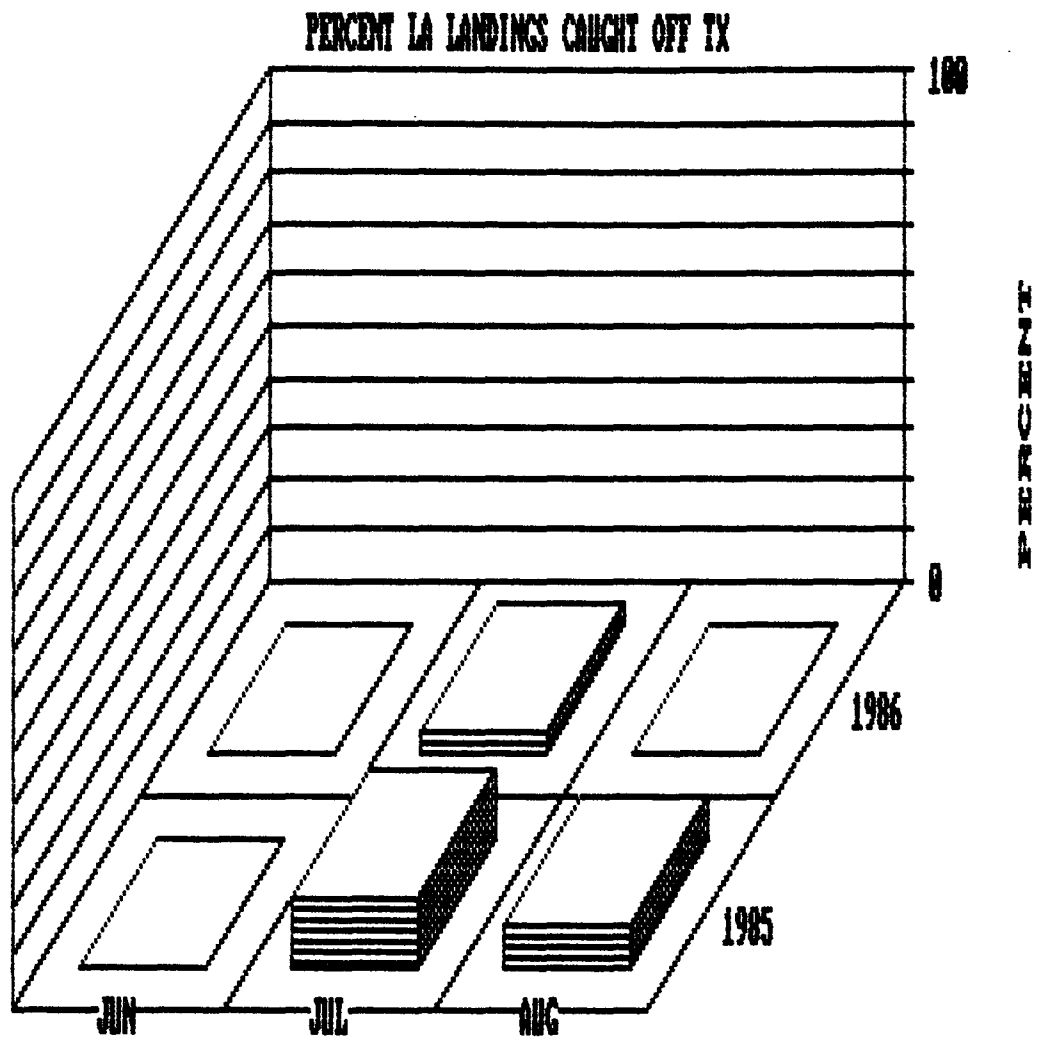

Figure 25. Percentage of offshore brown shrimp landed in Louisiana, but caught off Texas.

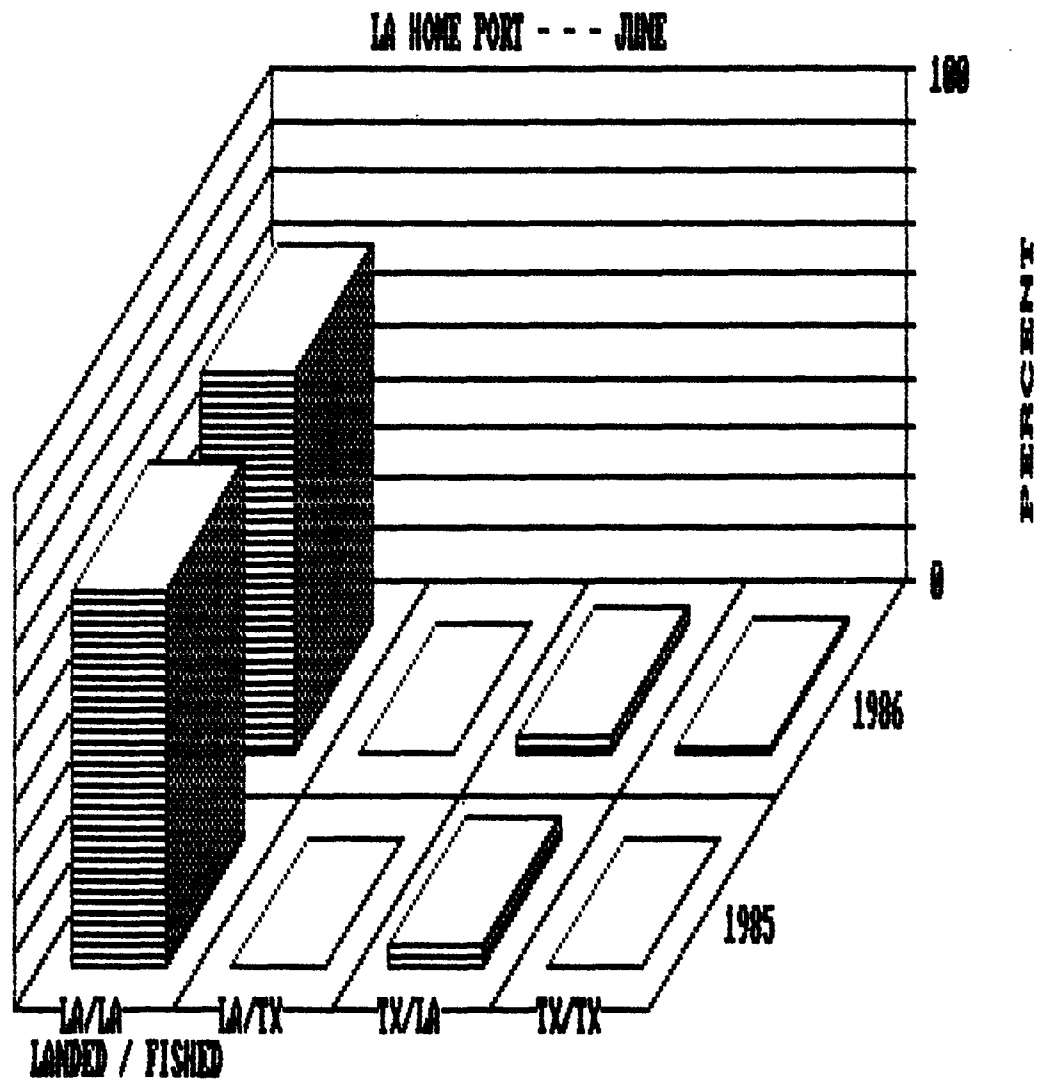

Figure 26. Percentage of offshore brown shrimp caught and then landed, in different Louisiana-Texas combinations, by Louisiana home port vessels in June.

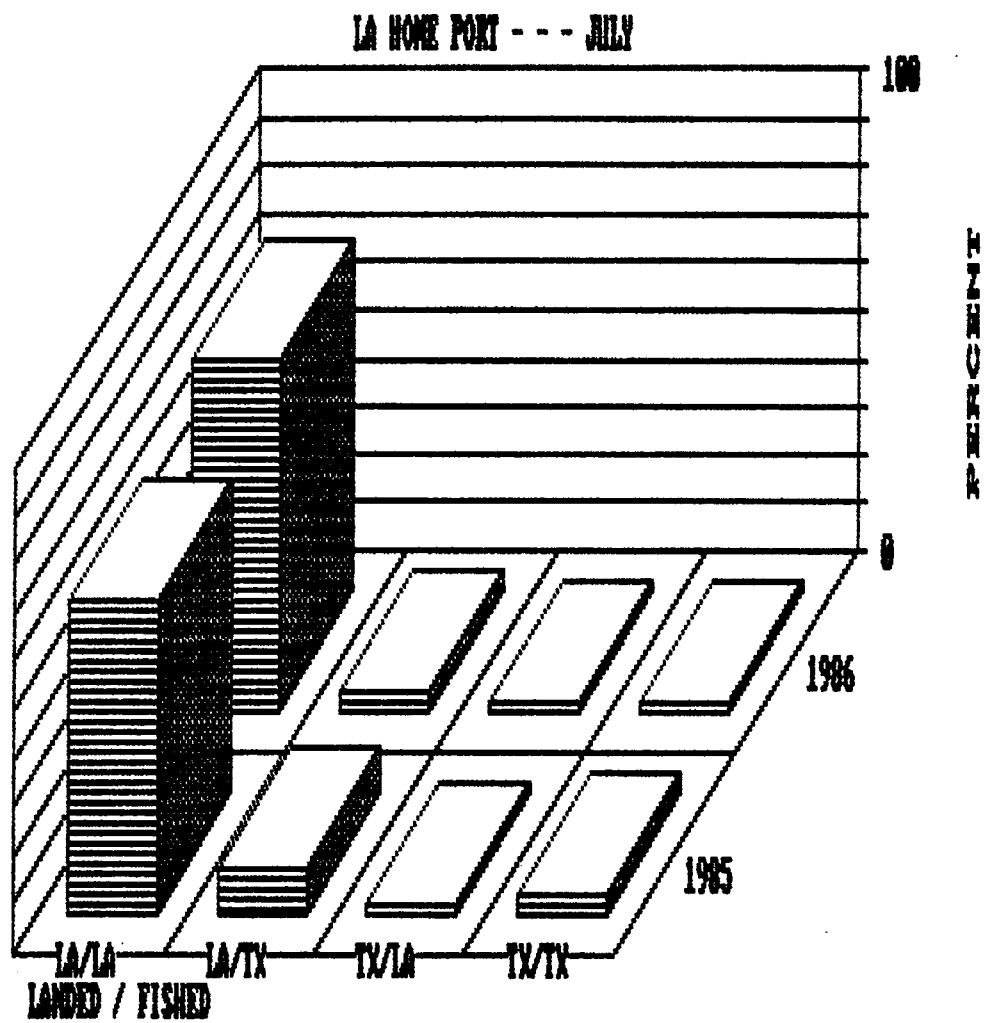

Figure 27. Percentage of offshore brown shrimp caught and then landed, in different Louisiana-Texas combinations, by Louisiana home port vessels in July.

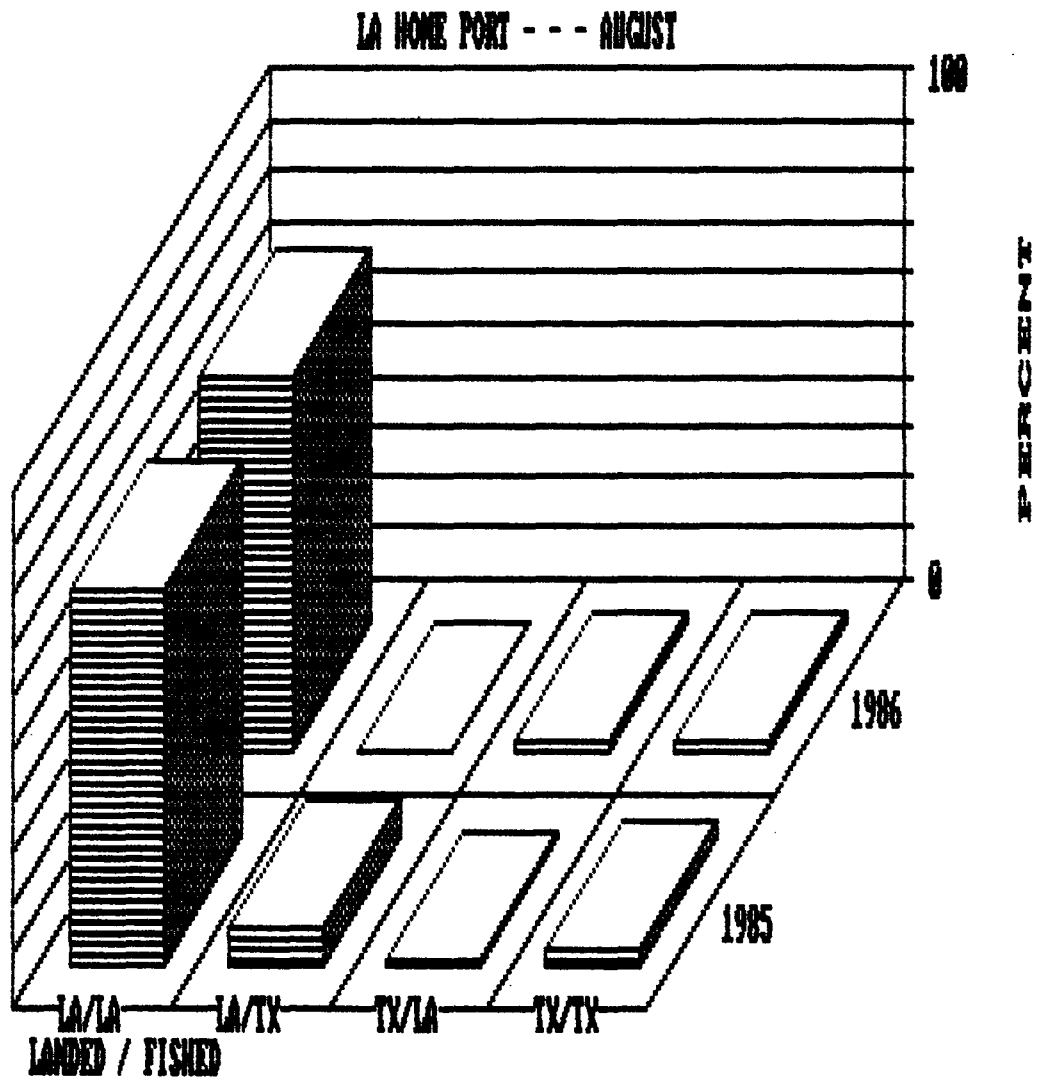

Figure 28. Percentage of offshore brown shrimp caught and then landed, in different Louisiana-Texas combinations, by Louisiana home port vessels in August.

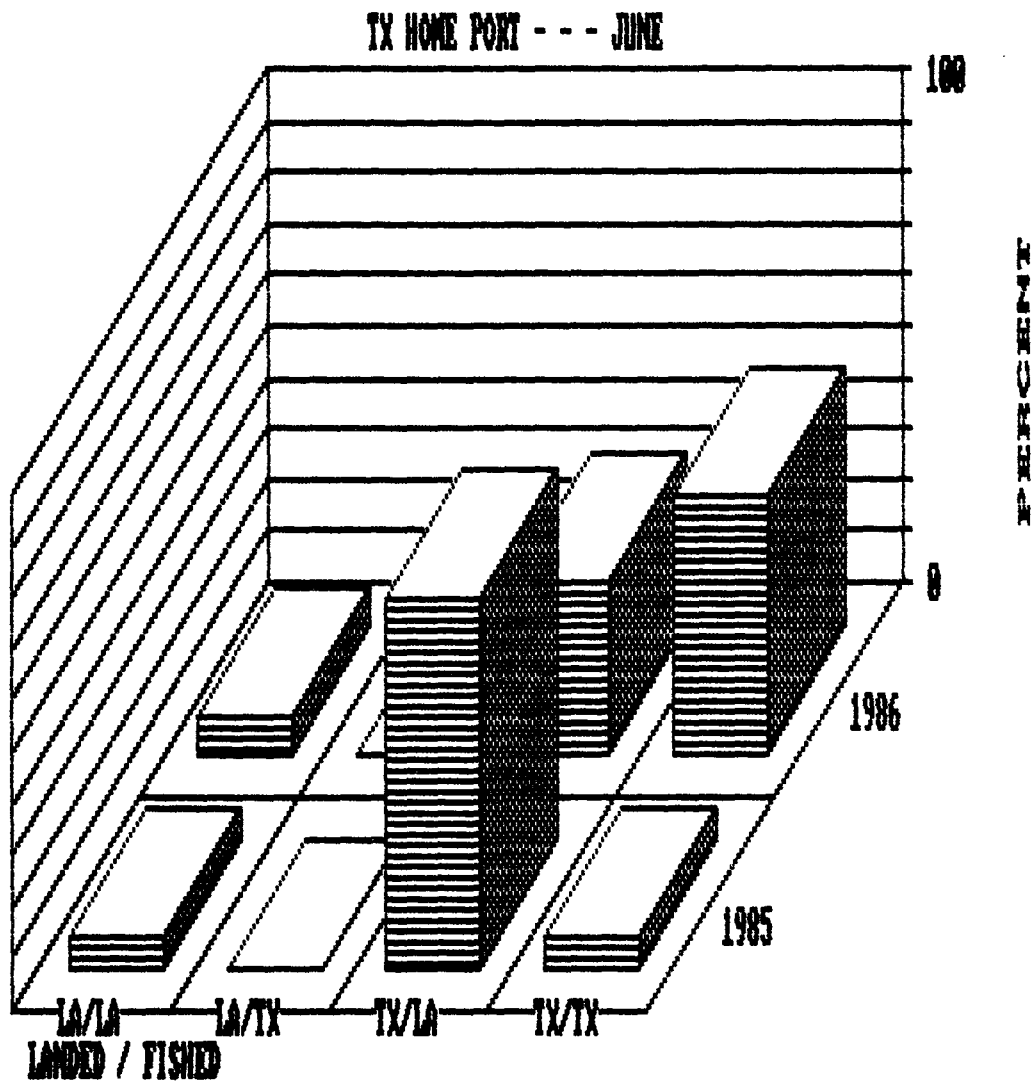

Figure 29. Percentage of offshore brown shrimp caught and then landed, in different Louisiana-Texas combinations, by Texas home port in June.

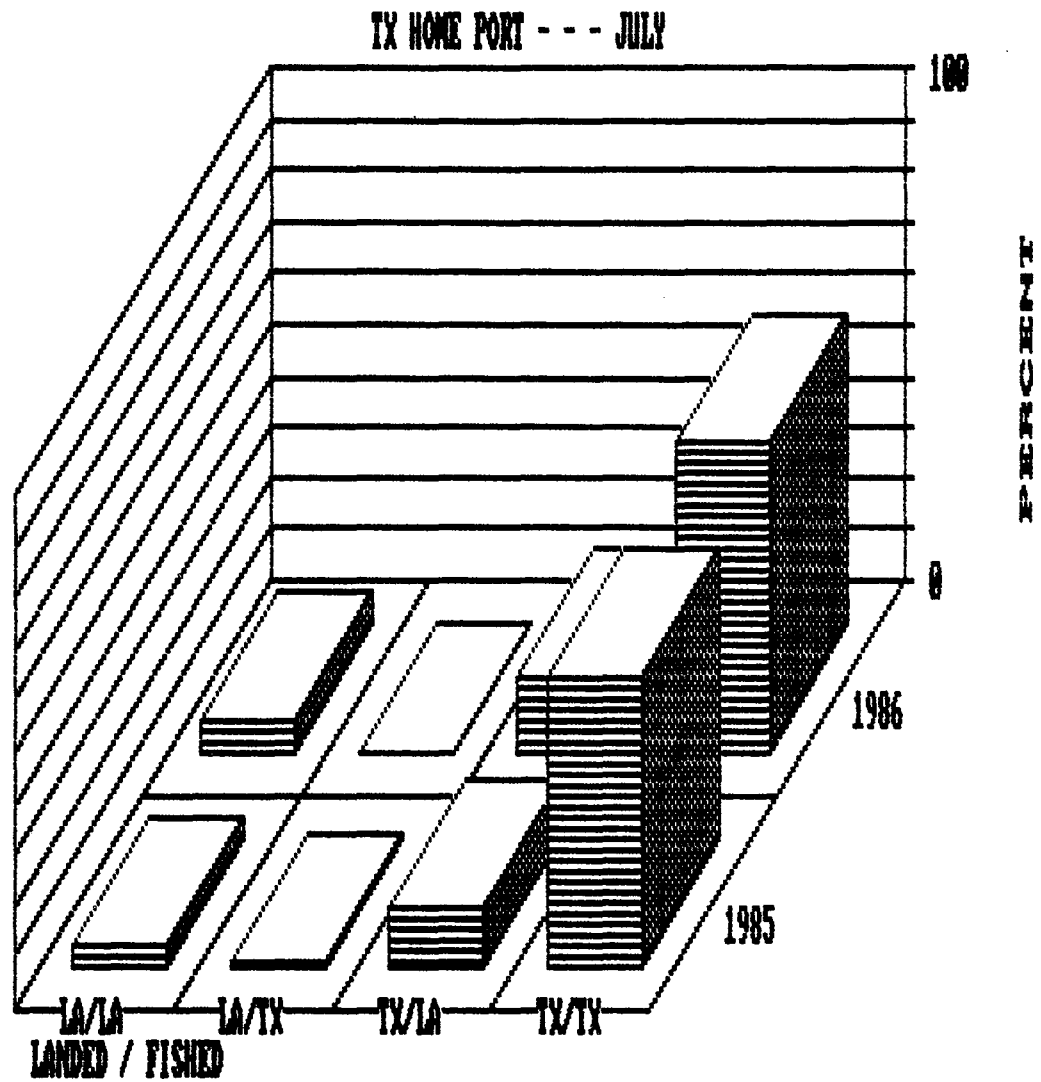

Figure 30. Percentage of offshore brown shrimp caught and then landed, in different Louisiana-Texas combinations, by Texas home port in July.

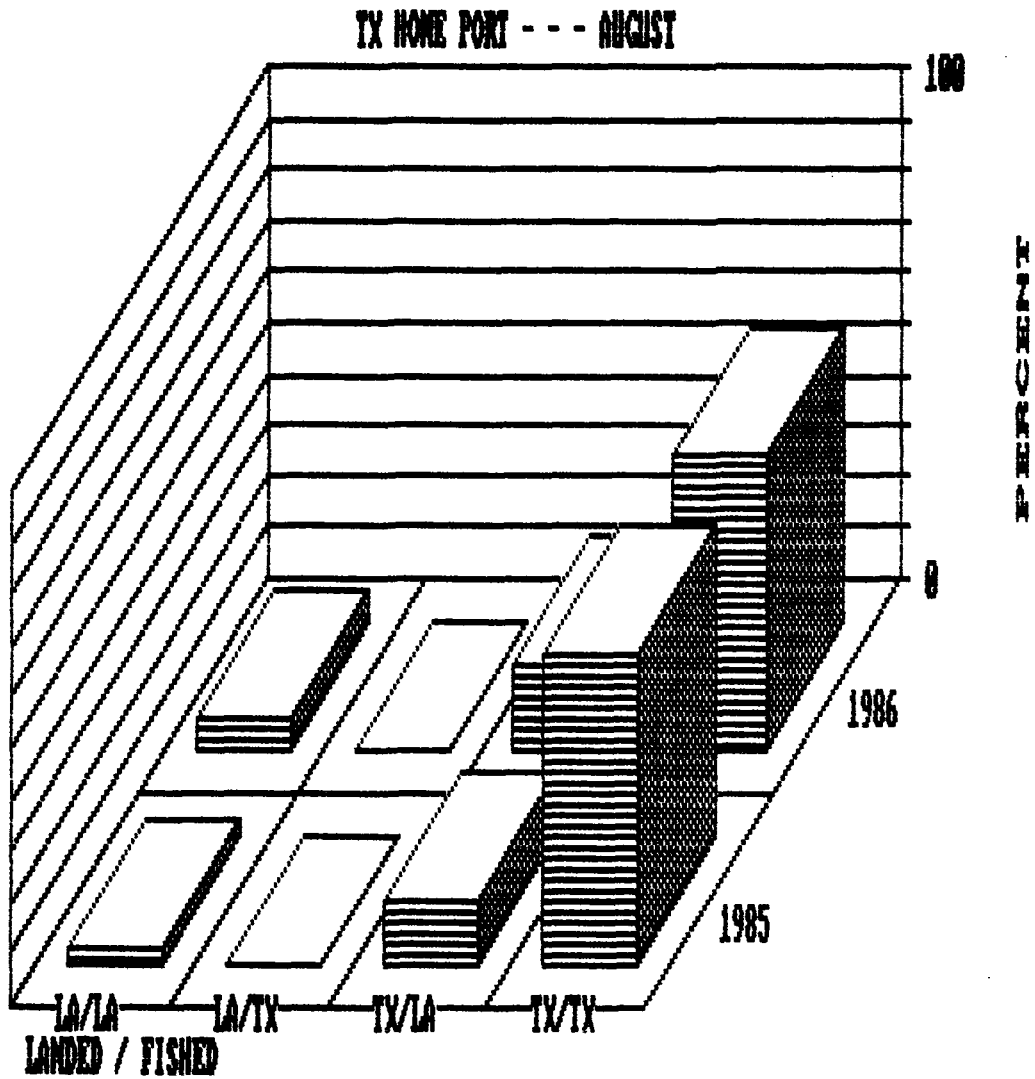

Figure 31. Percentage of offshore brown shrimp caught and then landed, in different Louisiana-Texas combinations, by Texas home port in August.

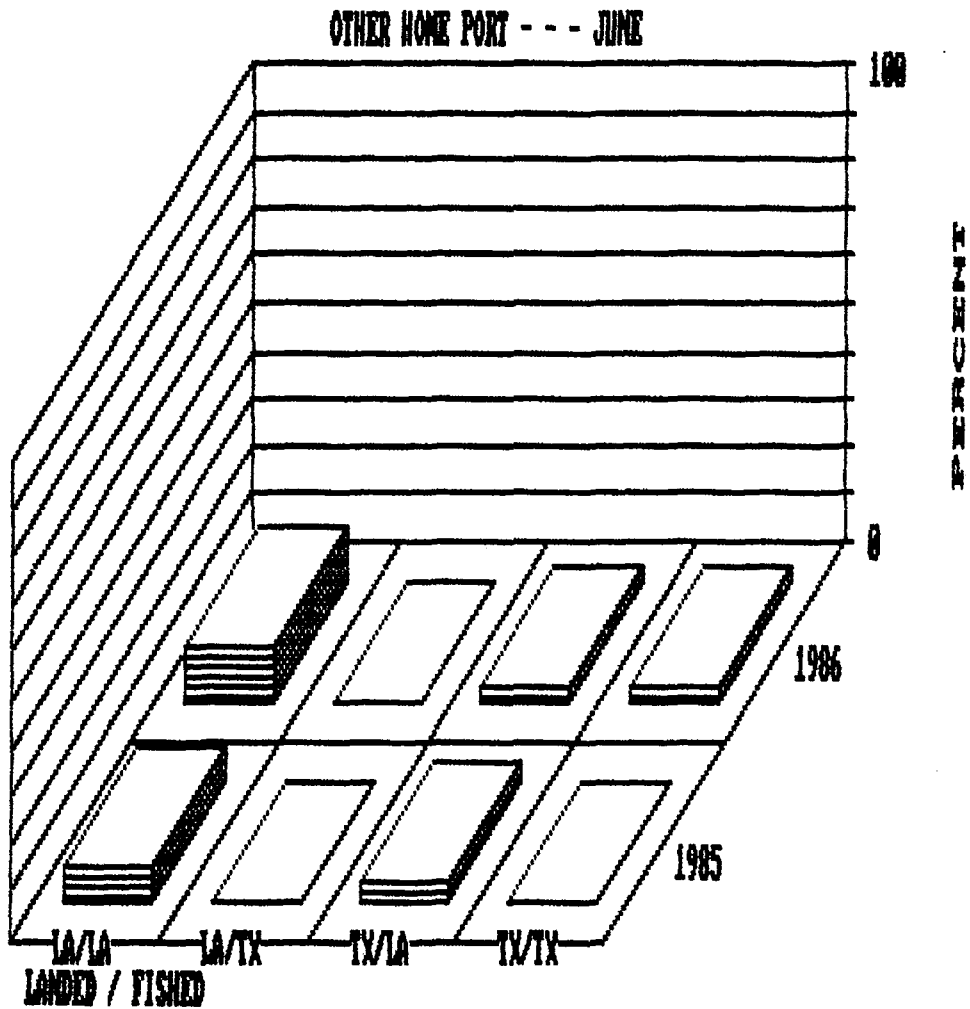

Figure 32. Percentage of offshore brown shrimp caught and then landed, in different Louisiana-Texas combinations, by other (Florida, Alabama and Mississippi) home port vessels in June.

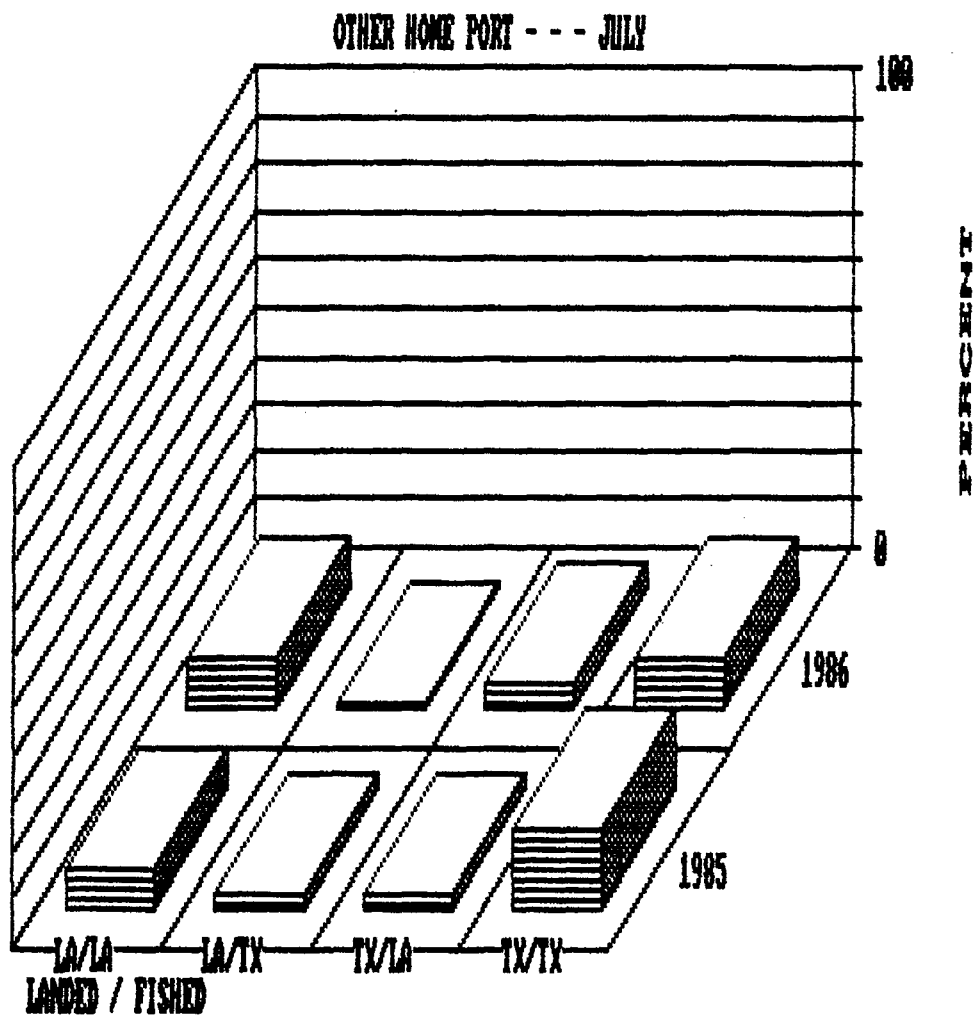

Figure 33. Percentage of offshore brown shrimp caught and then landed, in different Louisiana-Texas combinations, by other (Florida, Alabama and Mississippi) home port vessels in July.

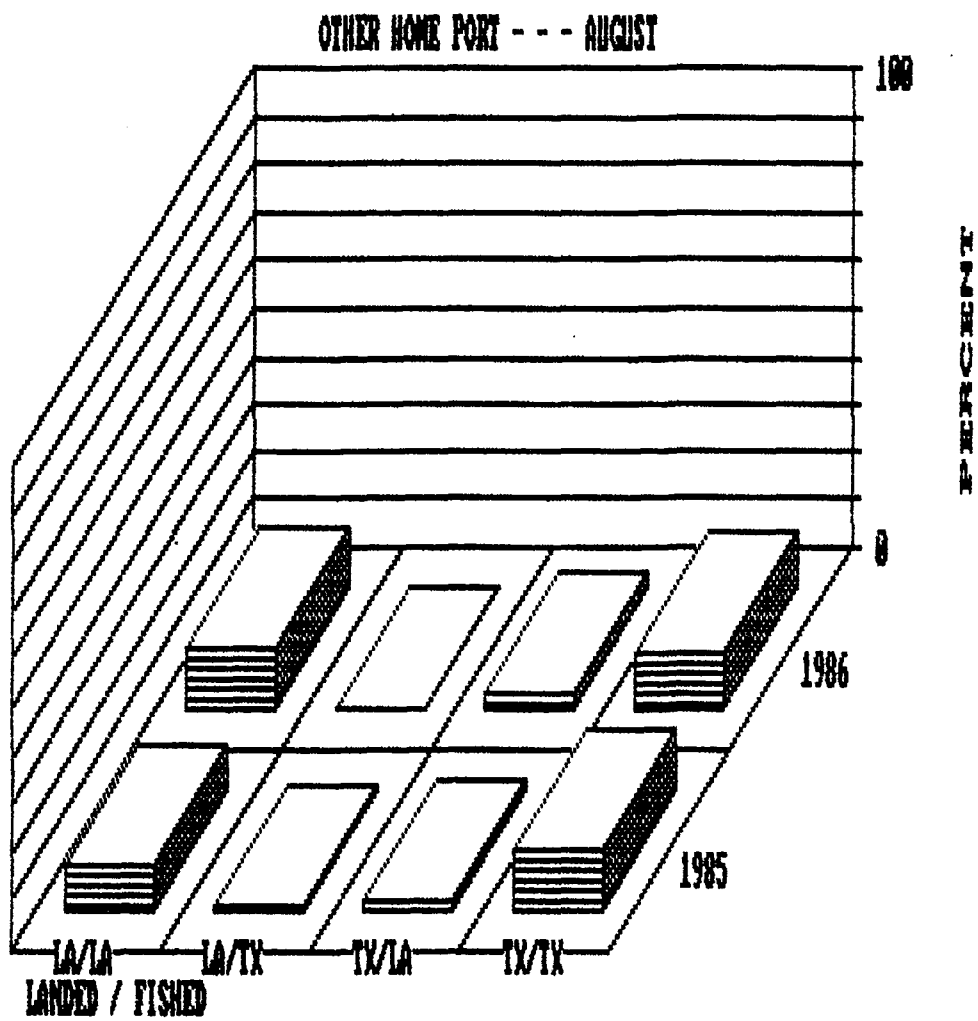

Figure 34. Percentage of offshore brown shrimp caught and then landed, in different Louisiana-Texas combinations, by other (Florida, Alabama and Mississippi) home port vessels in August.

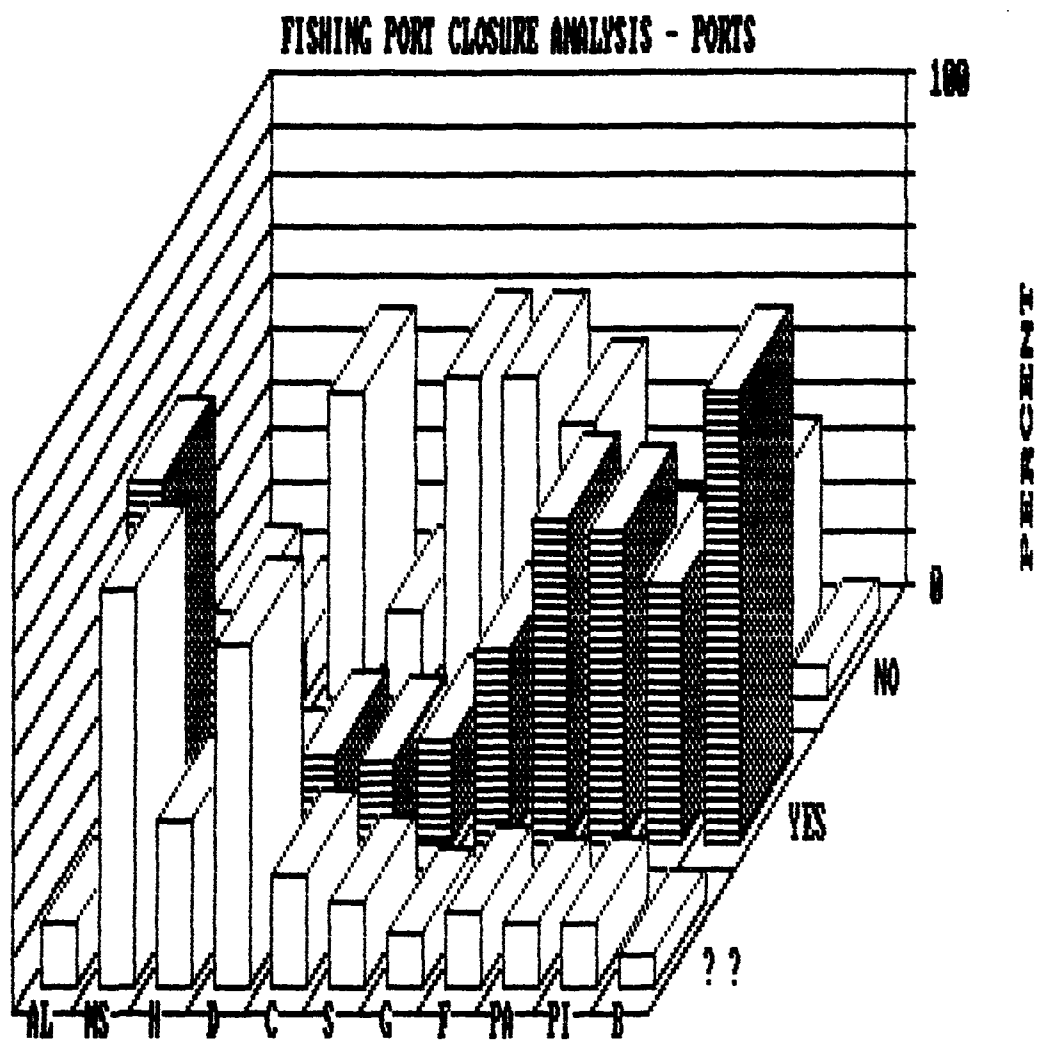

Figure 35. Percentage of interviewed captains from various fishing ports, who had no opinion about the closure (??), who liked the closure (YES) and who didn't like the closure (NO). (AL=Alabama; MS=Mississippi; H=Houma, LA; D=Delcambre, LA; C=Cameron, LA; S=Sabine, TX; G=Galveston, TX; F=Freeport, TX; PA=Port Aransas, TX; PI=Port Isabel, TX; B=Brownsville, TX).

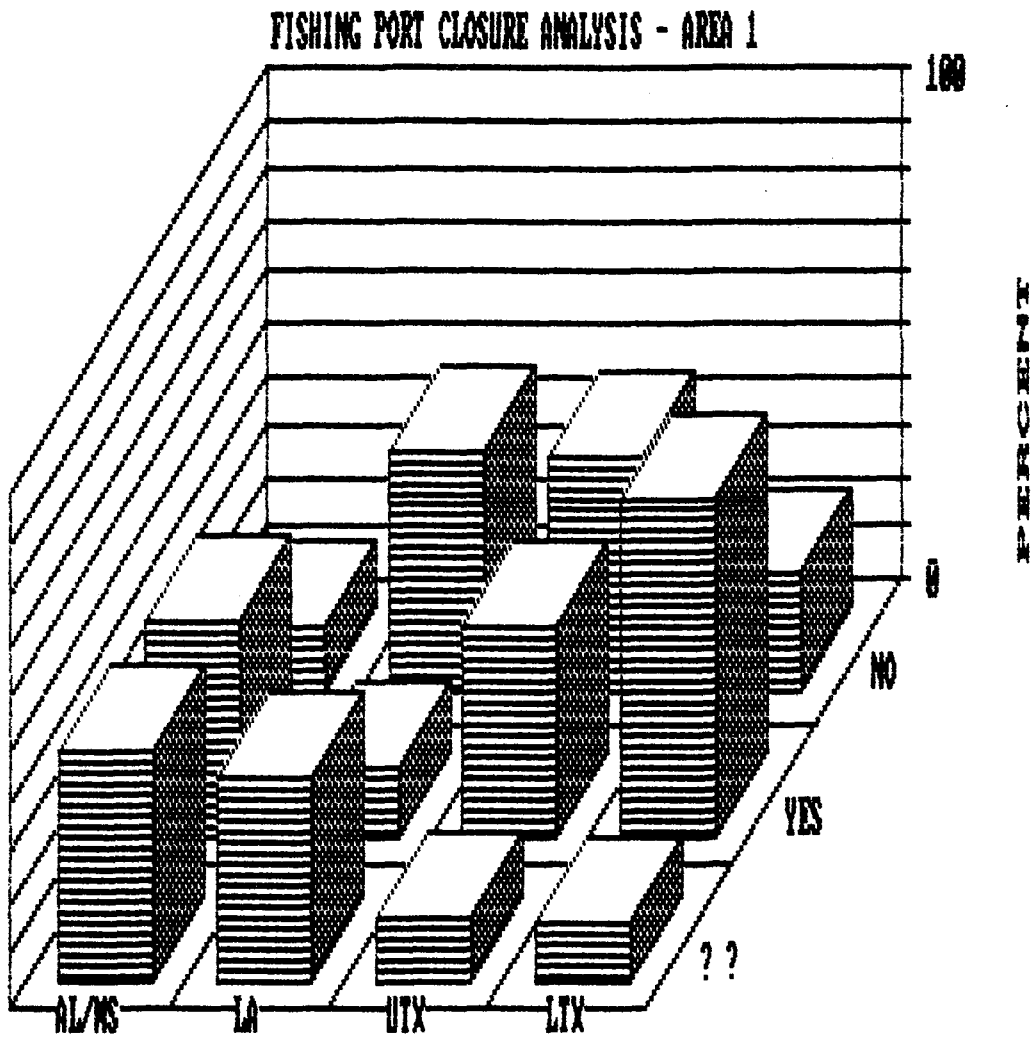

Figure 36. Percentage of interviewed captains from various Gulf areas (Alabama-Mississippi, Louisiana, upper Texas coast and lower Texas coast), who had no opinion about the closure (??), who liked the closure (YES) and who didn't like the closure (NO).

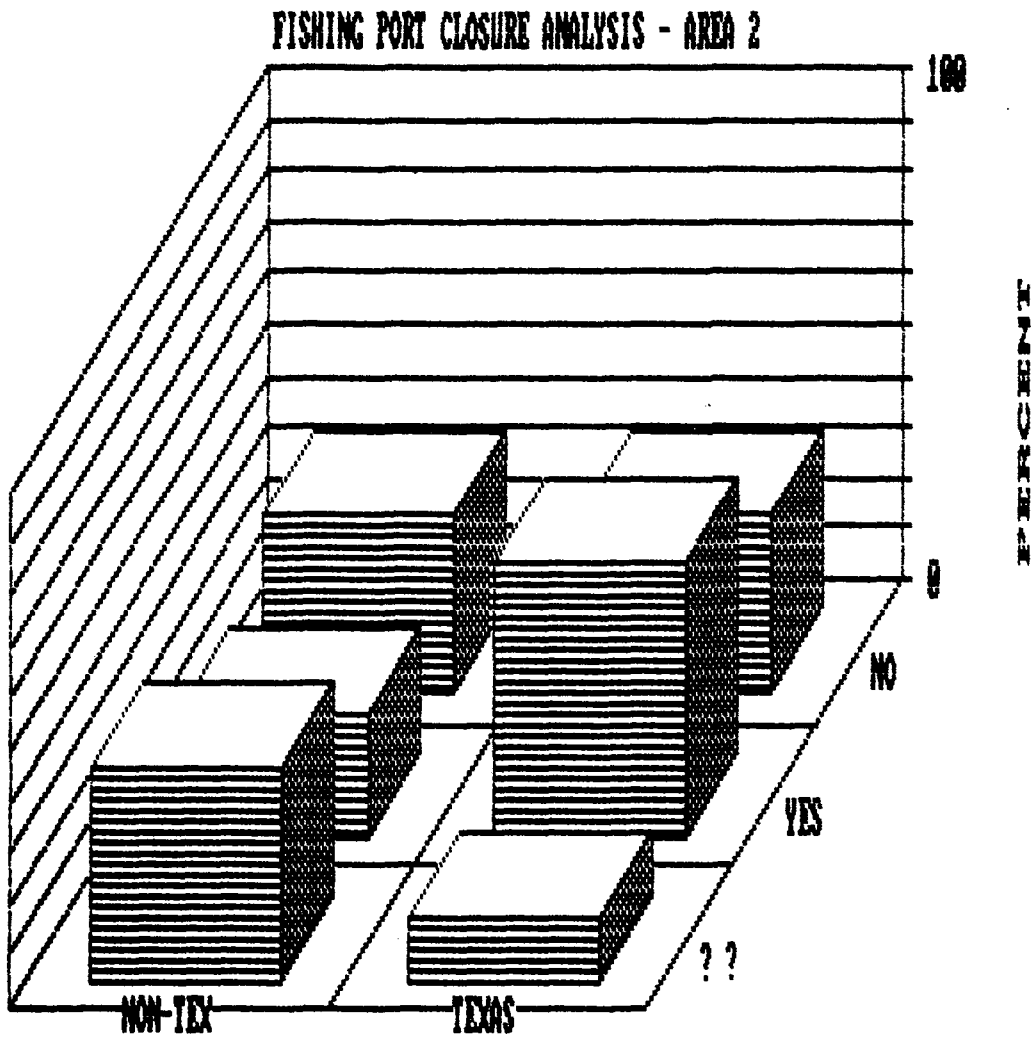

Figure 37. Percentage of interviewed Texas captains and non-Texas captains with comments about the closure (?? = no opinion, YES = liked closure and NO = didn't like closure).

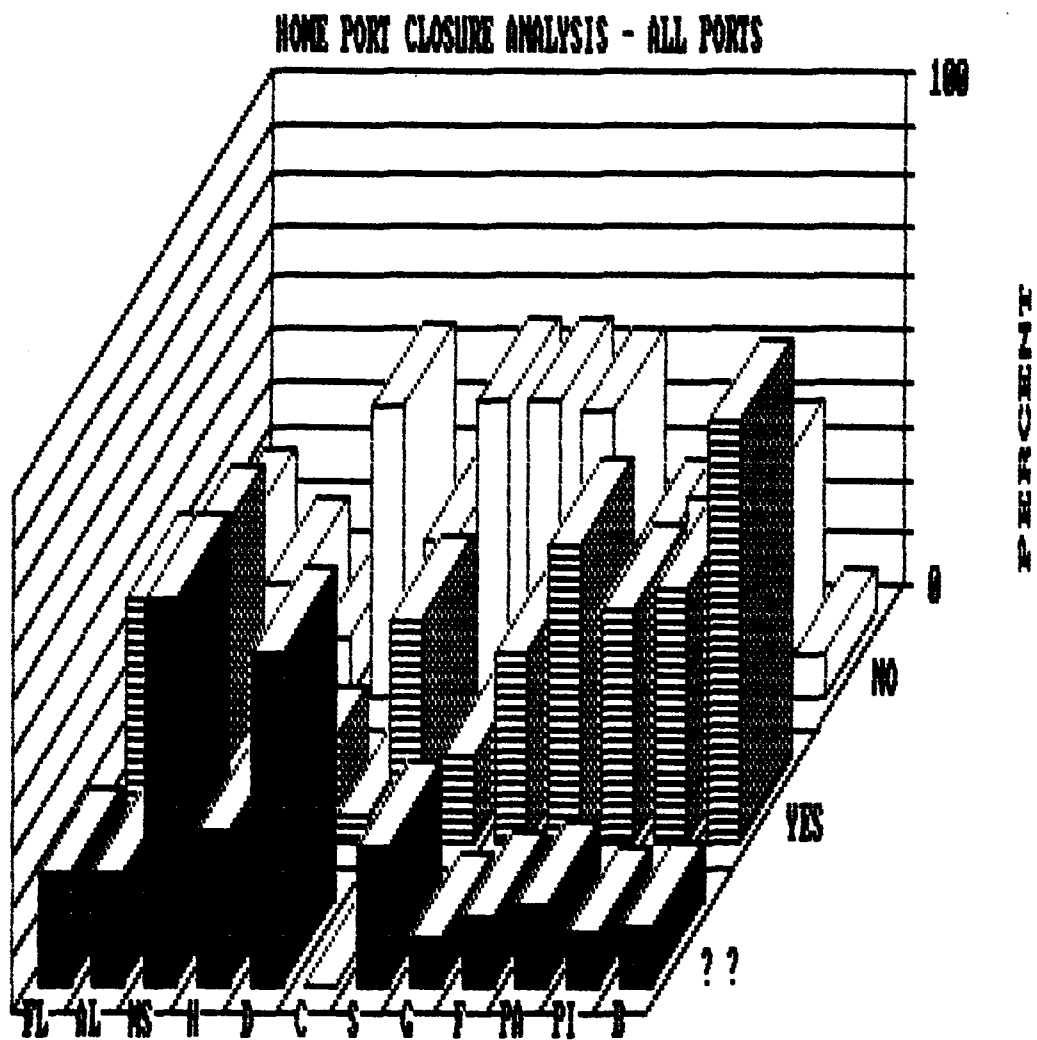

Figure 38. Percentage of interviewed captains from various fishing ports who had no opinion about the closure (??), who liked the closure (YES) and who didn't like the closure (NO). (FL=Florida; AL=Alabama; MS=Mississippi; H=Houma, LA; D=Delcambre, LA; C=Cameron, LA; S=Sabine, TX; G=Galveston, TX; F=Freeport, TX; PA=Port Aransas, TX; PI=Port Isabel, TX; B=Brownsville, TX.

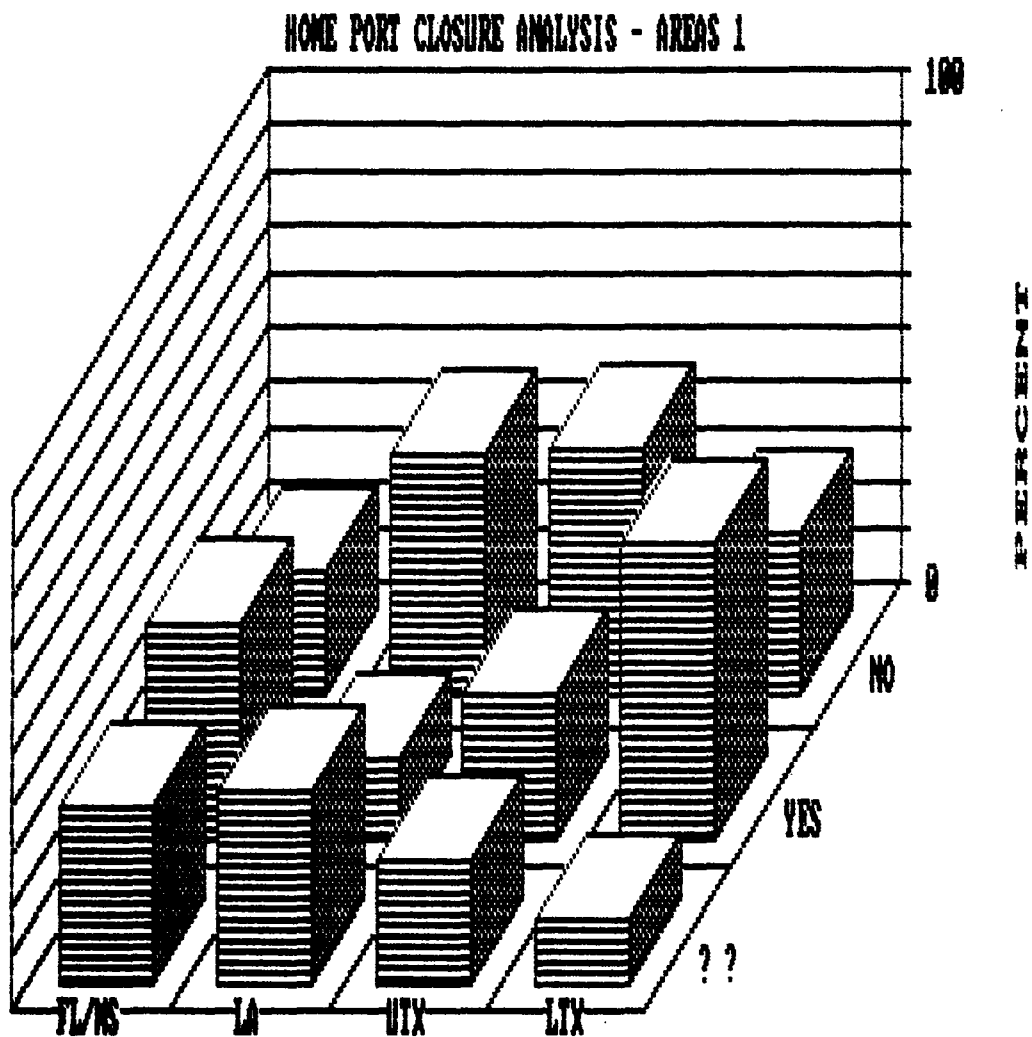

Figure 39. Percentage of interviewed captains from various Gulf areas (Florida-Mississippi, Louisiana, upper Texas coast and lower Texas coast), who had no opinion about the closure (??), who liked the closure (YES) and who didn't like the closure (NO).

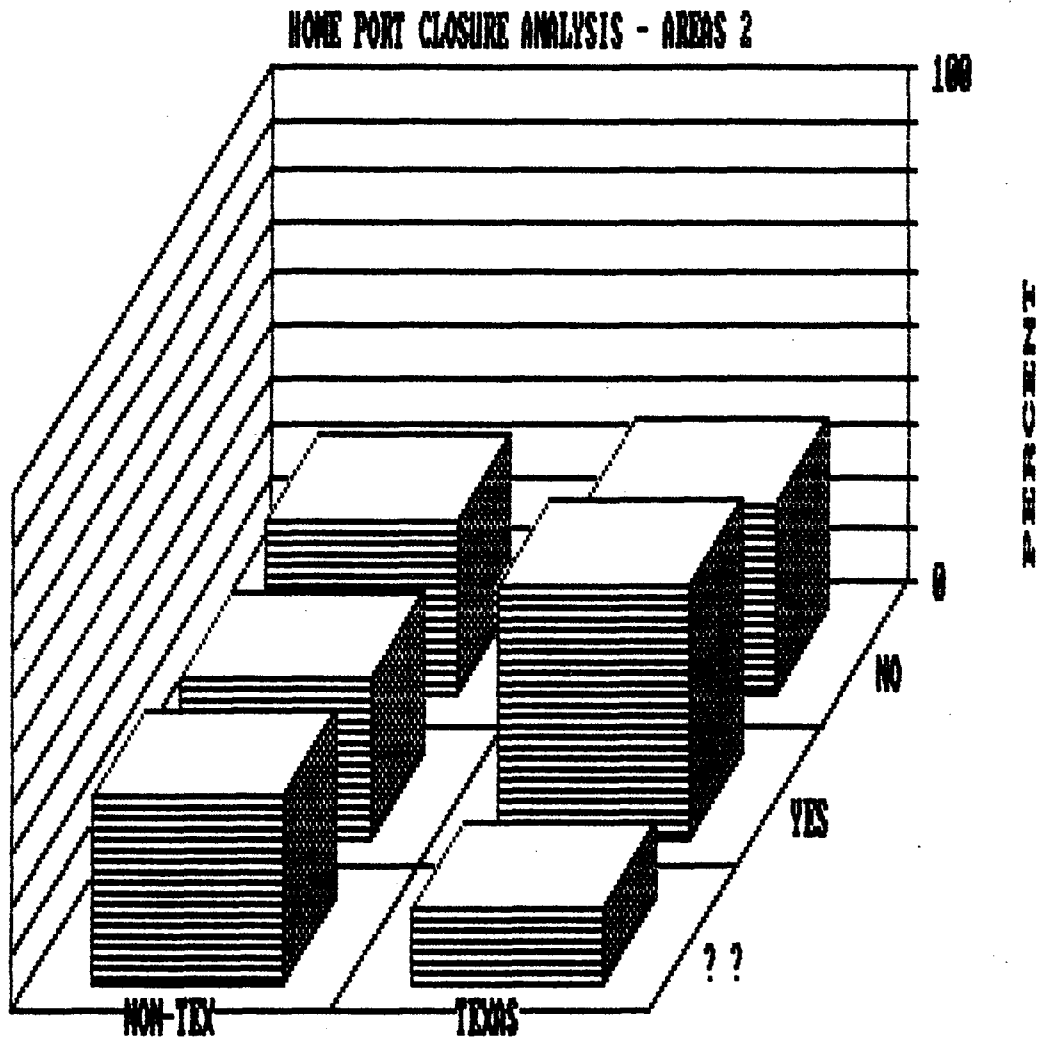

Figure 40. Percentage of interviewed Texas captains and non-Texas captains with comments about the closure (?? = no opinion, YES = liked closure and NO = didn't like closure).

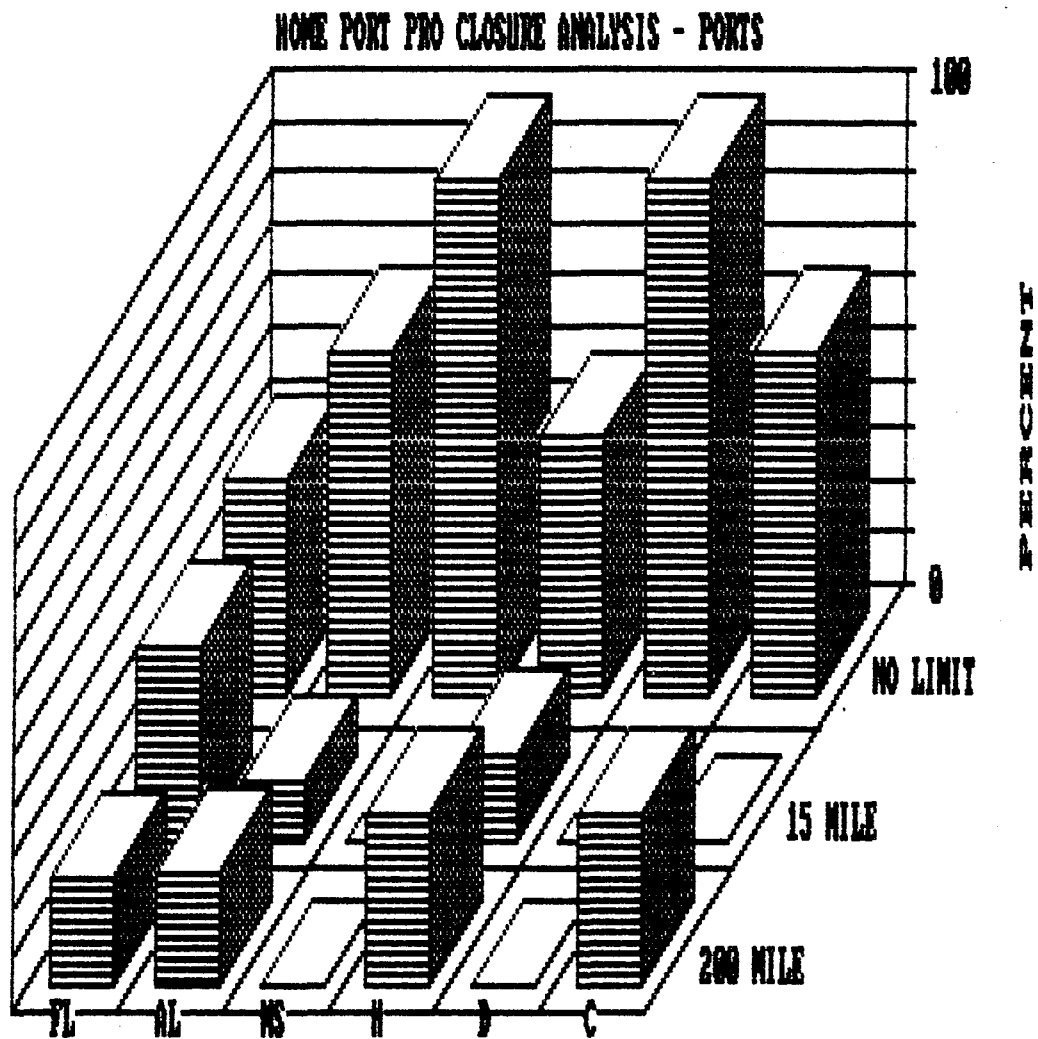

Figure 41. Percentage of responses, listed by non-Texas ports and suggested closure limits, from captains who favored a closure of the FCZ. (FL=Florida; AL=Alabama; MS=Mississippi; H=Houma,LA; D=Delcambre,LA; C=Cameron,IA).

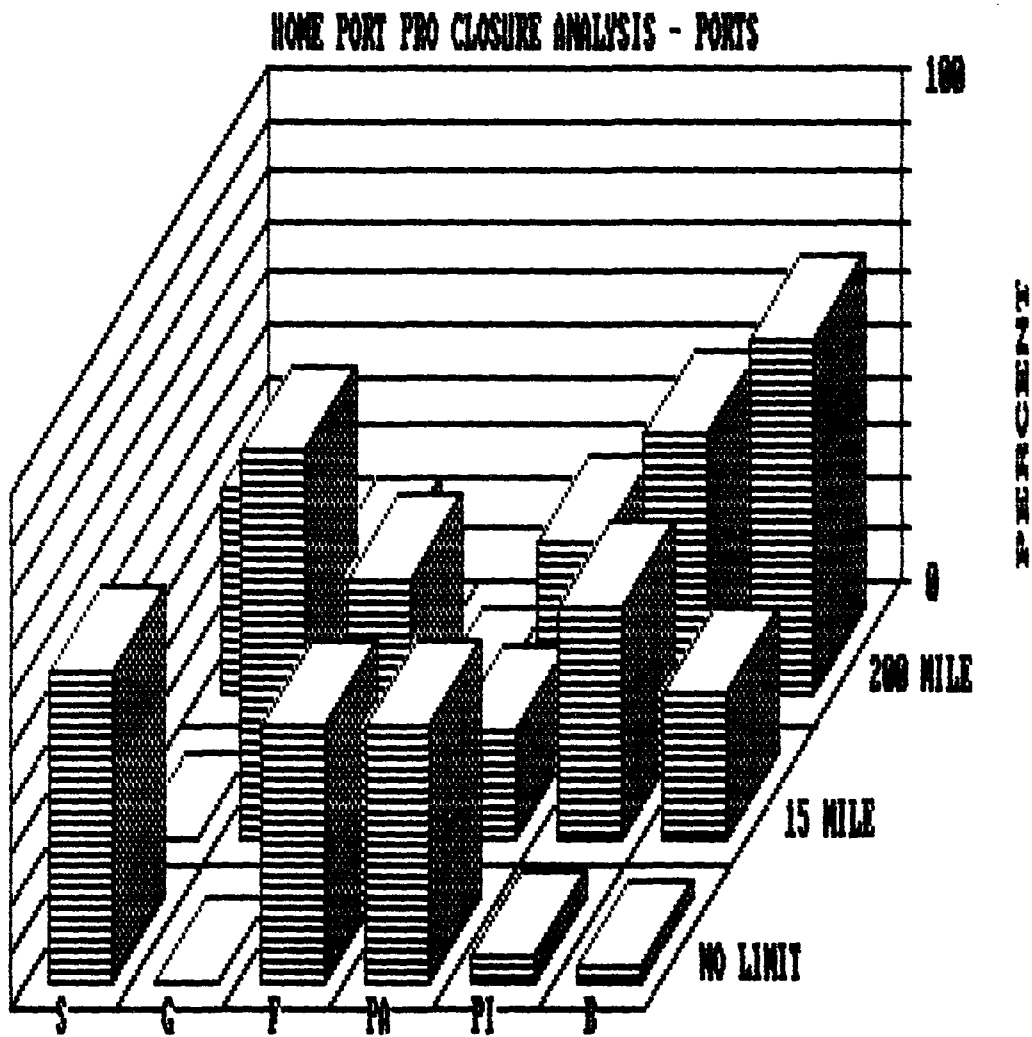

Figure 42. Percentage of responses, listed by Texas ports and suggested closure limits, from captains who favored a closure of the FCZ. (S=Sabine, G=Galveston, F=Freeport, PA=Port Aransas, PI=Port Isabel and B=Brownsville).

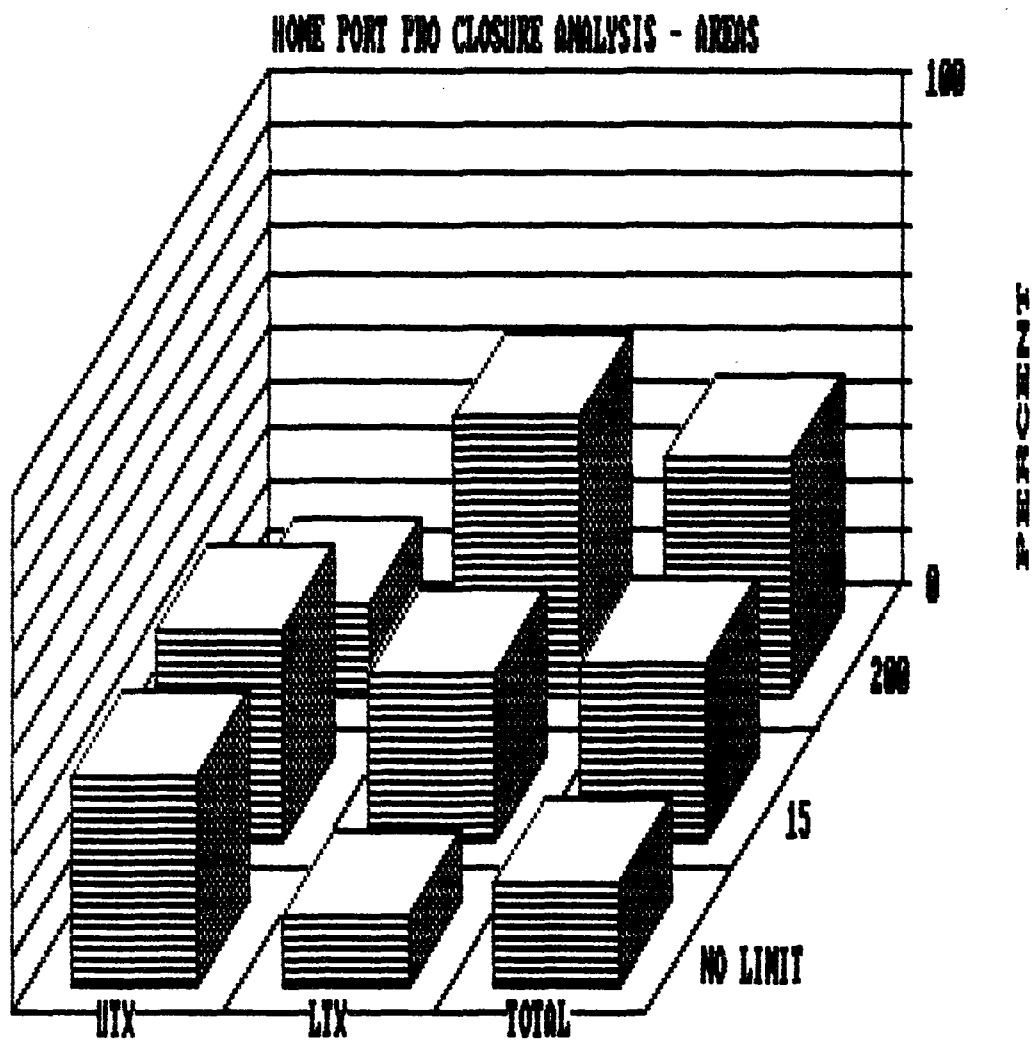

Figure 43. Percentage of responses, listed by Texas areas and suggested closure limits, from captains who favored a closure of the FCZ. (UTX=upper Texas coast; LTX=lower Texas coast).

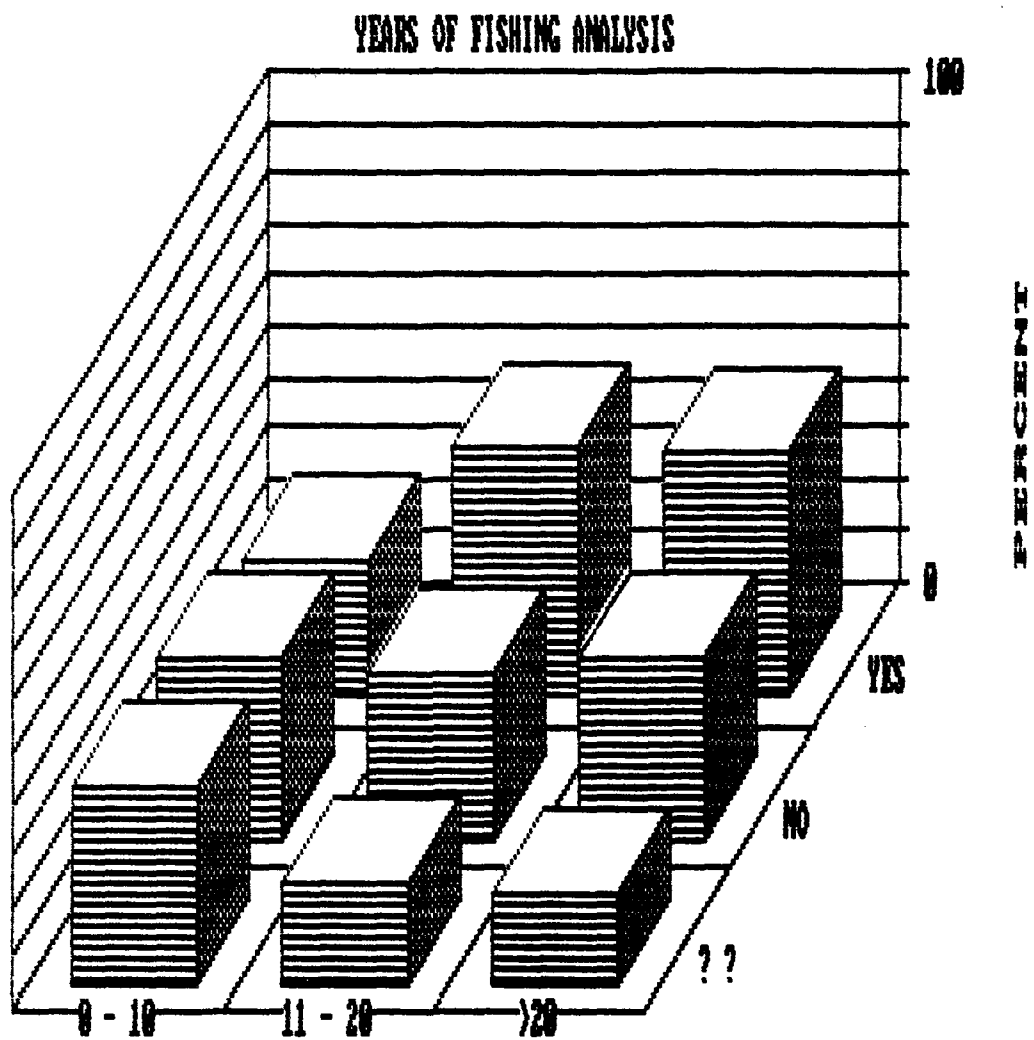

Figure 44. Percentage of interviewed captains commenting about the FCZ closure, listed by number of years fishing for shrimp and response. (?? = no opinion, YES = liked closure and NO = doesn't like closure).

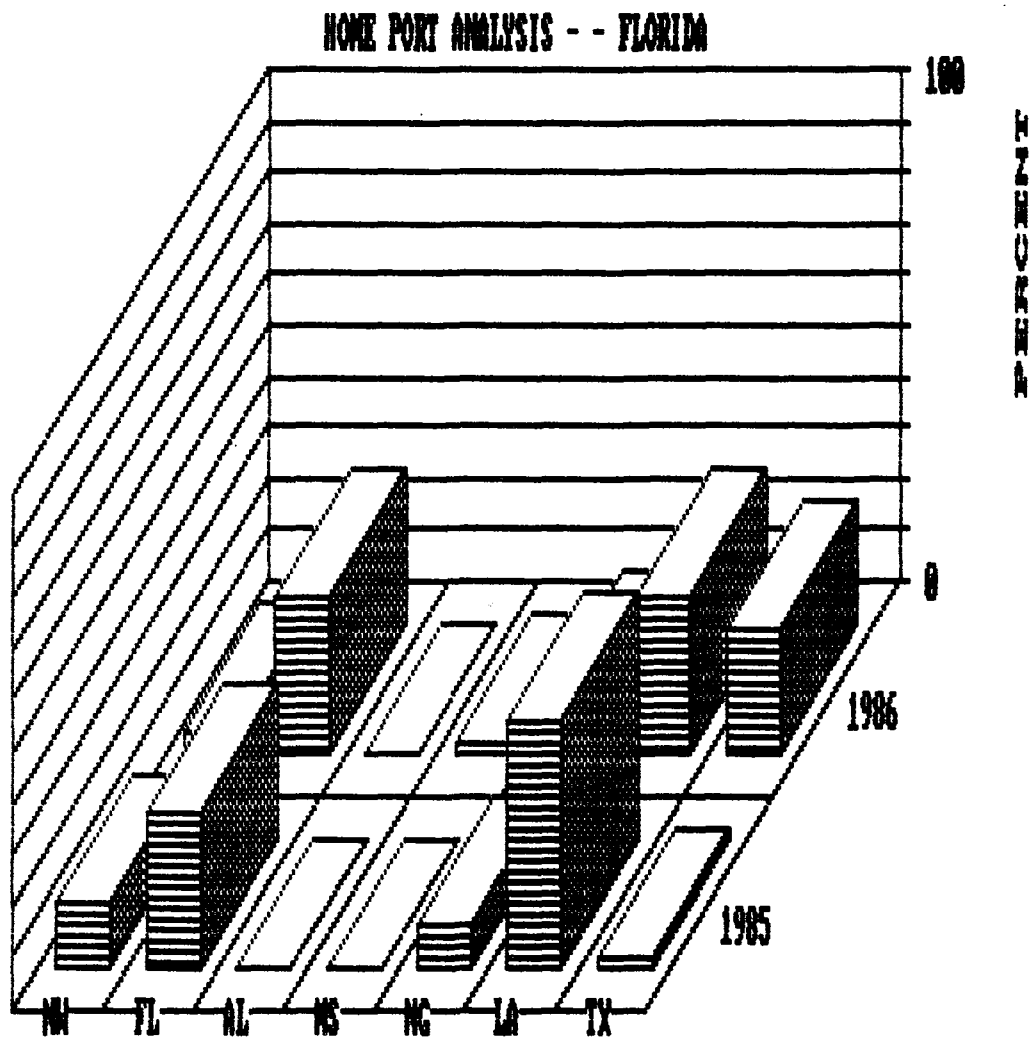

Figure 45. Determination by percentages of where interviewed captains with a home port in Florida fished for shrimp, if they did, during the 1985 closure period and the 1986 closure period. (NW = didn't fish for shrimp; F=Florida; AL=Alabama; MS=Mississippi; NG=Northern Gulf of Mexico; LA=Louisiana; TX=Texas).

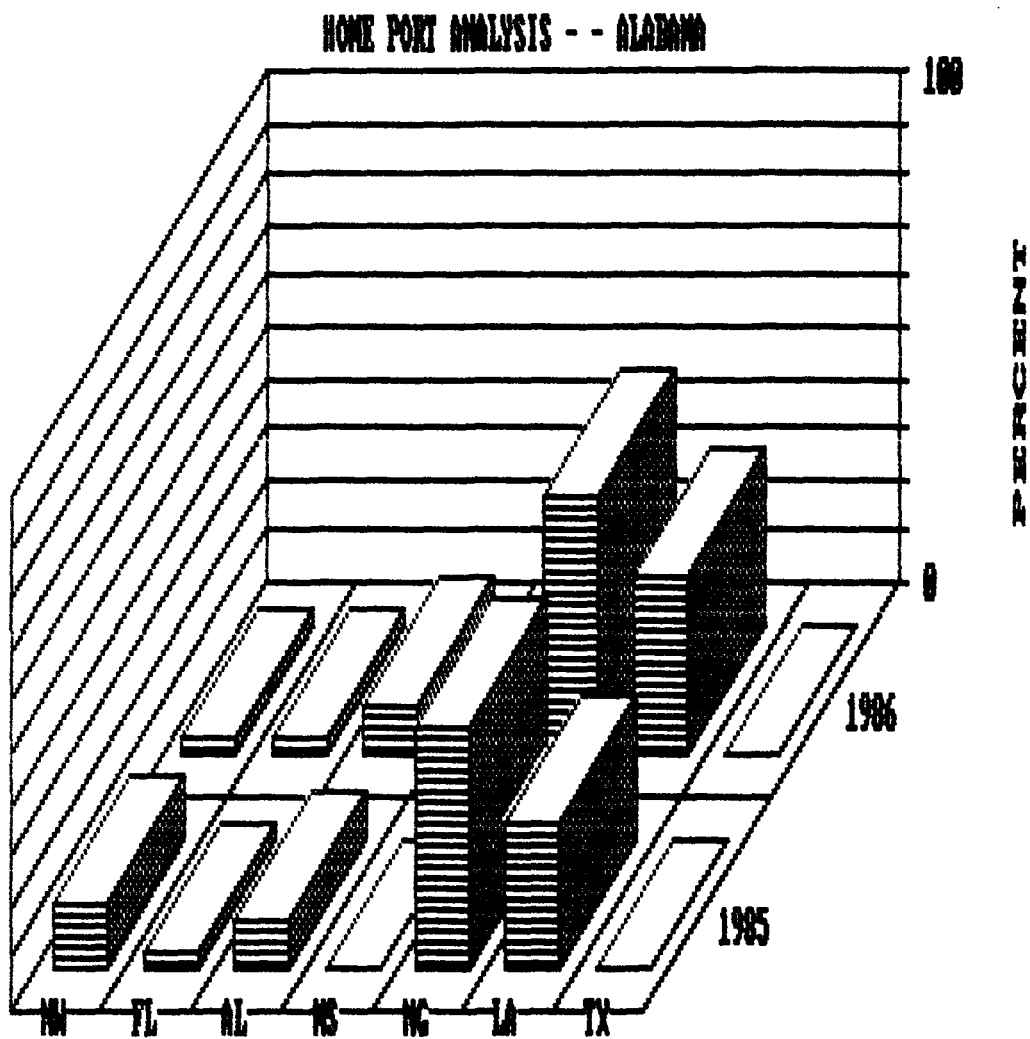

Figure 46. Determination by percentages of where interviewed captains with a home port in Alabama fished for shrimp, if they did, during the 1985 closure period and the 1986 closure period. (NW = didn't fish for shrimp; FL=Florida; AL=Alabama; MS=Mississippi; NG=Northern Gulf of Mexico; LA=Louisiana; TX=Texas).

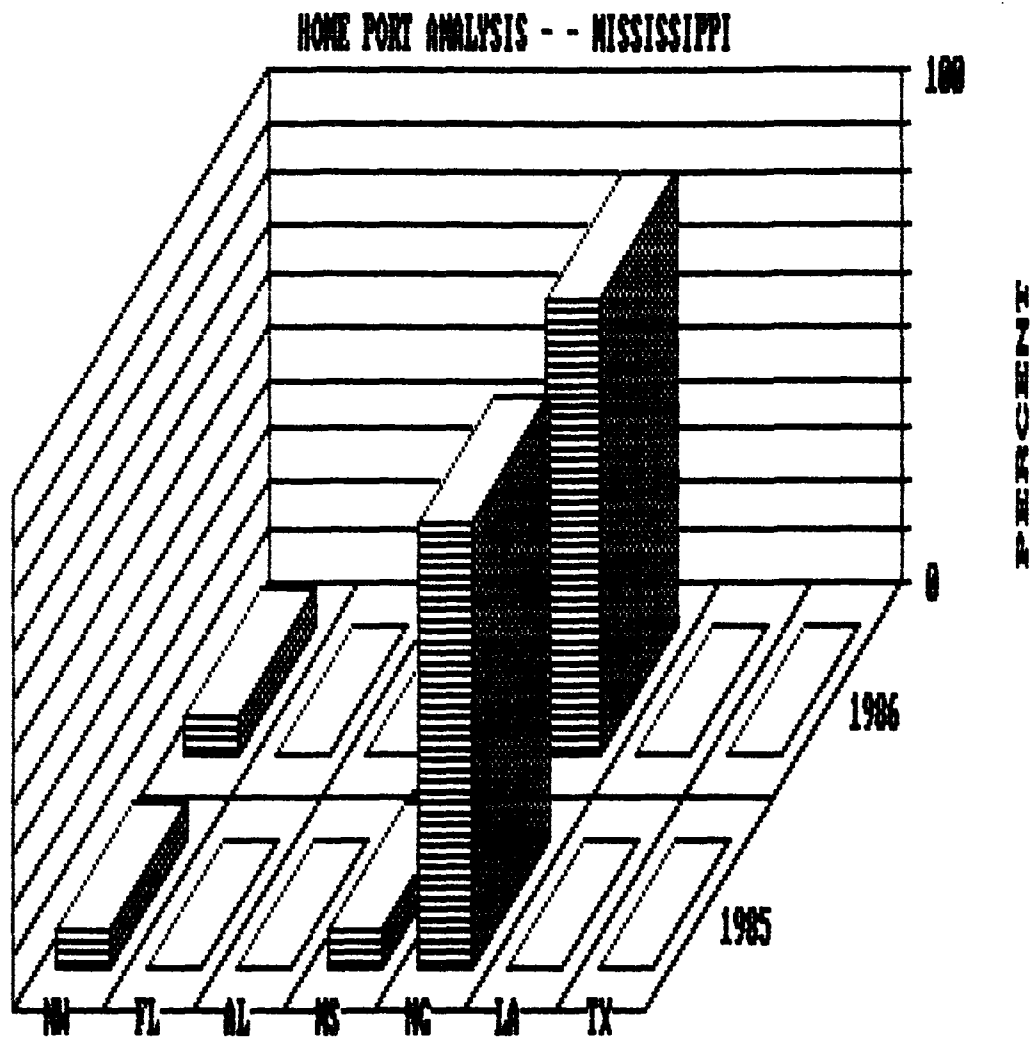

Figure 47. Determination by percentages of where interviewed captains with a home port in Mississippi fished for shrimp, if they did, during the 1985 closure period and the 1986 closure period. (NW = didn't fish for shrimp; FL=Florida; AL=Alabama; MS=Mississippi; NG=Northern Gulf of Mexico; LA=Louisiana, TX=Texas).

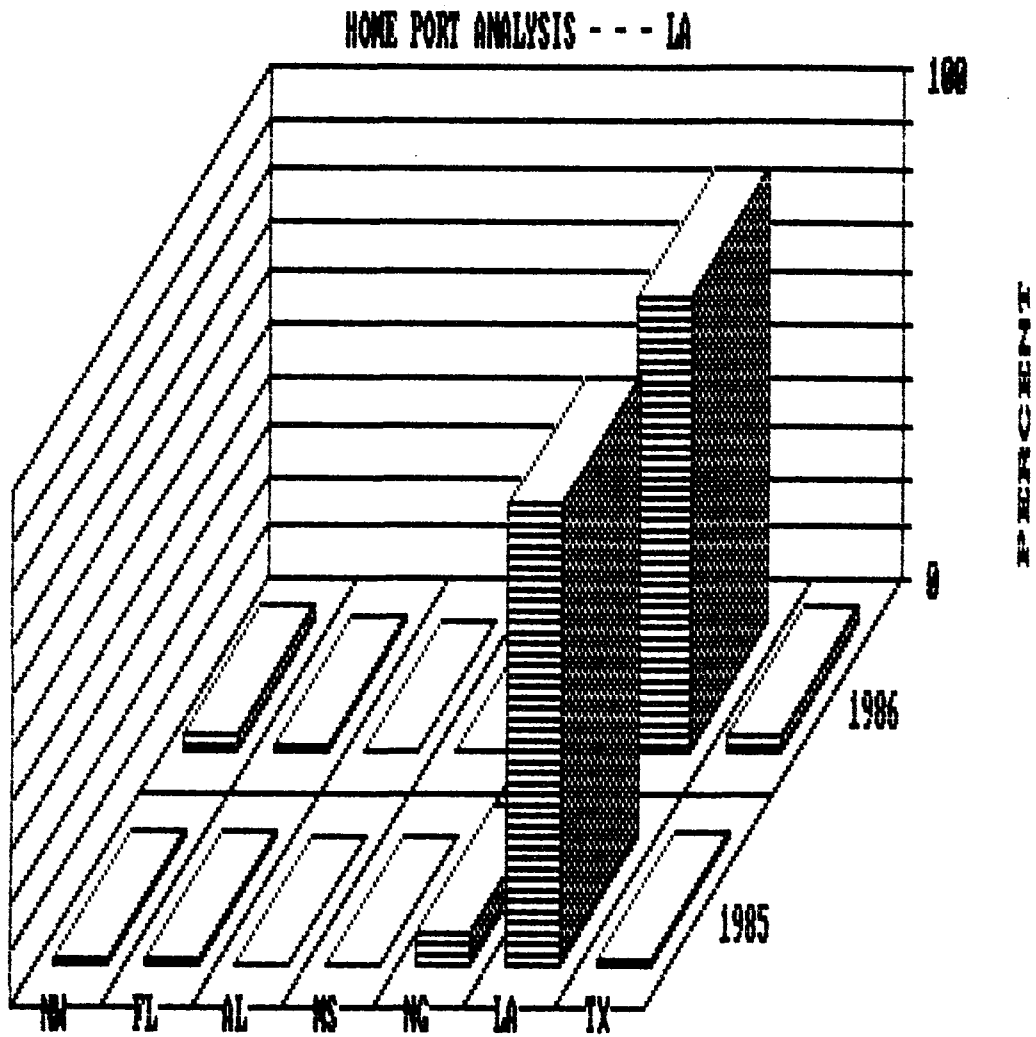

Figure 48. Determination by percentages of where interviewed captains with a home port in Louisiana fished for shrimp, if they did, during the 1985 closure period and the 1986 closure period. (NW = didn't fish for shrimp; FL=Florida; AL=Alabama; MS=Mississippi; NG=Northern Gulf of Mexico; LA=Louisiana; TX=Texas).

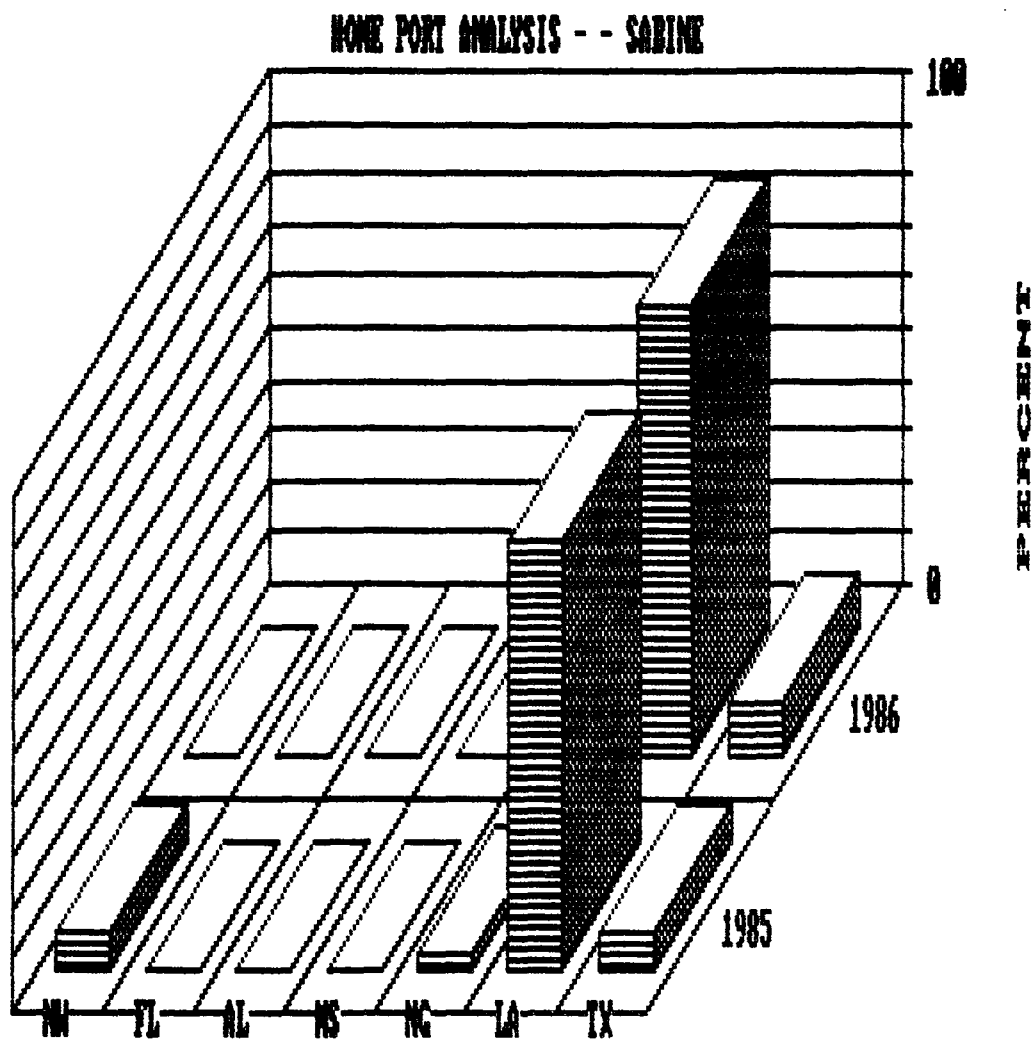

Figure 49. Determination by percentages of where interviewed captains with a home port in Sabine, Texas, fished for shrimp, if they did, during the 1985 closure period and the 1986 closure period. (NW = didn't fish for shrimp; FL=Florida; AL=Alabama; MS=Mississippi; NG=Northern Gulf of Mexico; LA=Louisiana; TX=Texas).

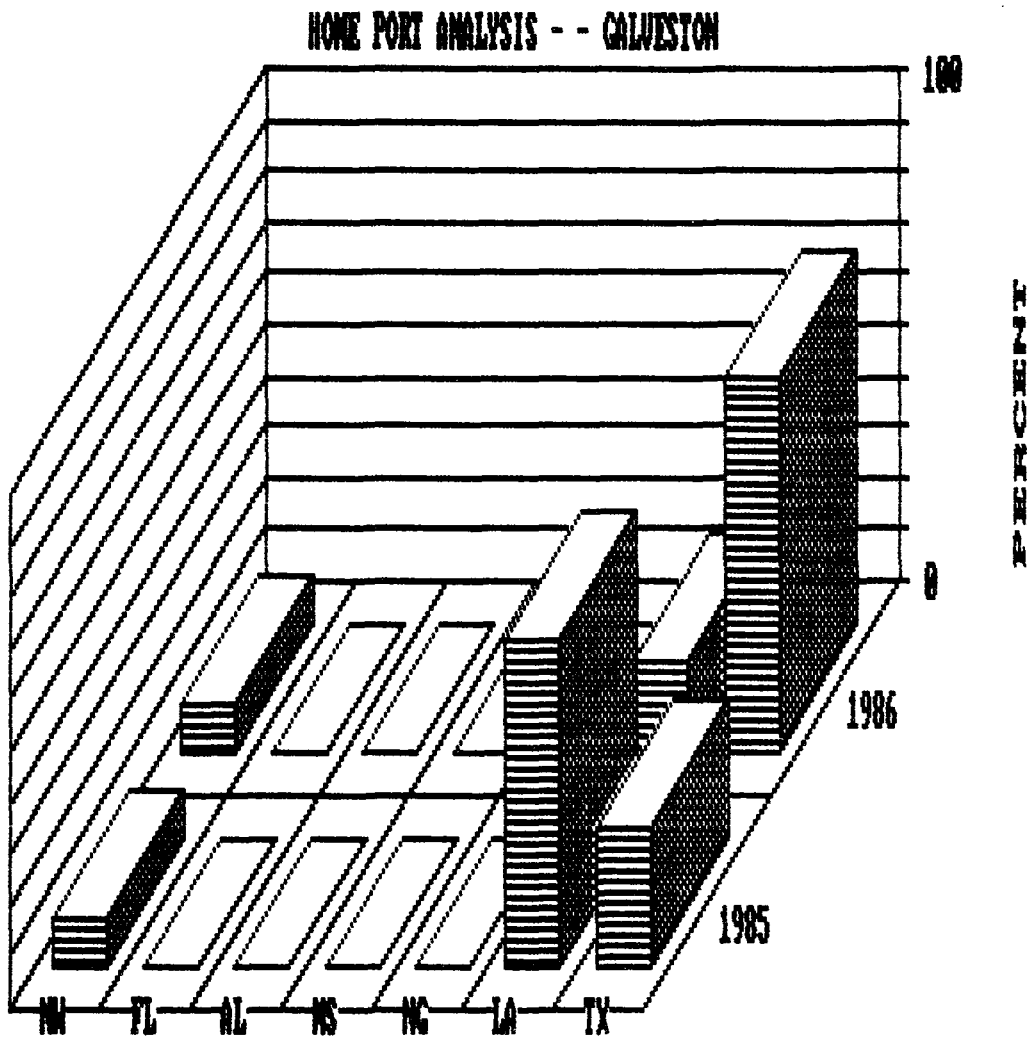

Figure 50. Determination by percentages of where interviewed captains with a home port in Galveston, Texas, fished for shrimp, if they did, during the 1985 closure period and the 1986 closure period. (NW = didn't fish for shrimp; FL=Florida; AL=Alabama; MS=Mississippi; NG=Northern Gulf of Mexico; LA=Louisiana; TX=Texas).

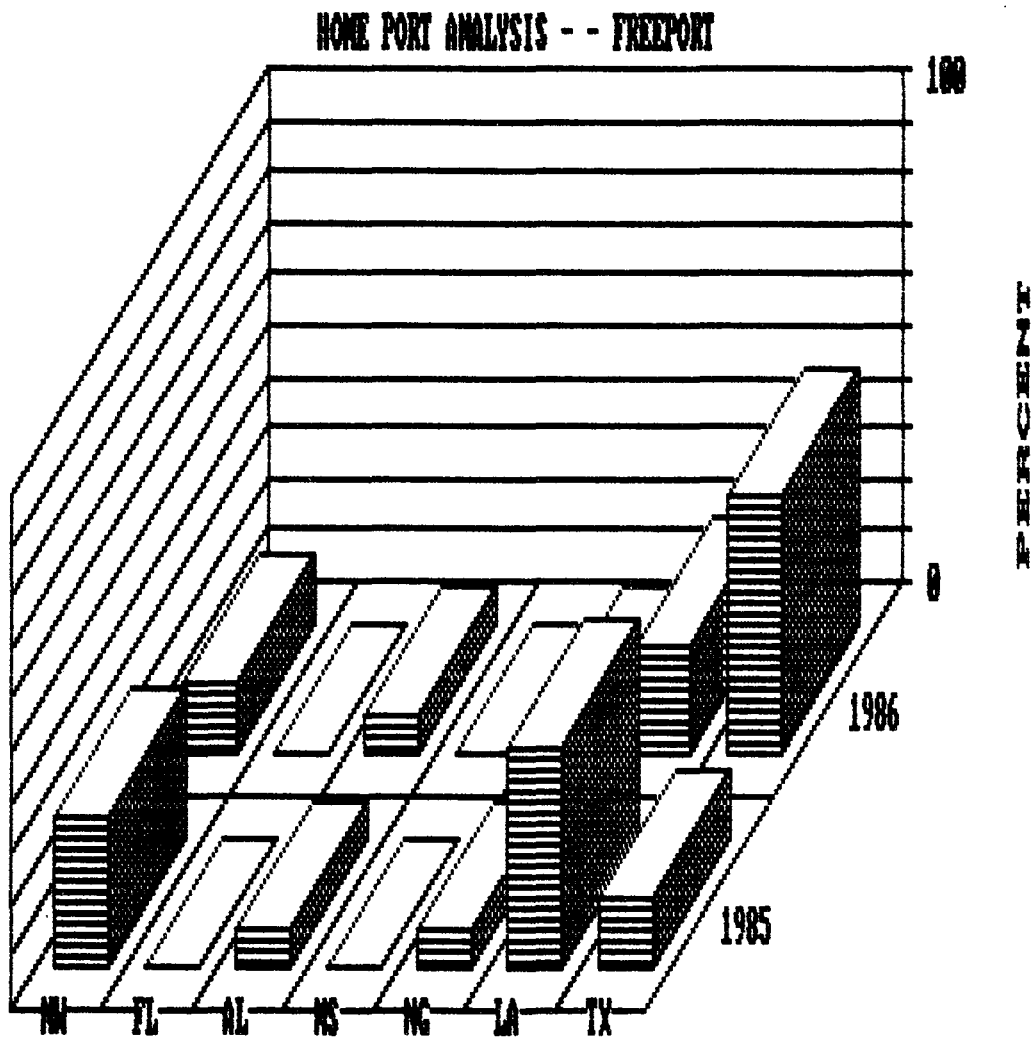

Figure 51. Determination by percentages of where interviewed captains with a home port in Freeport, Texas, fished for shrimp, if they did, during the 1985 closure period and the 1986 closure period. (NW = didn't fish for shrimp; FL=Florida; AL=Alabama; MS=Mississippi; NG=Northern Gulf of Mexico; LA=Louisiana; TX=Texas).

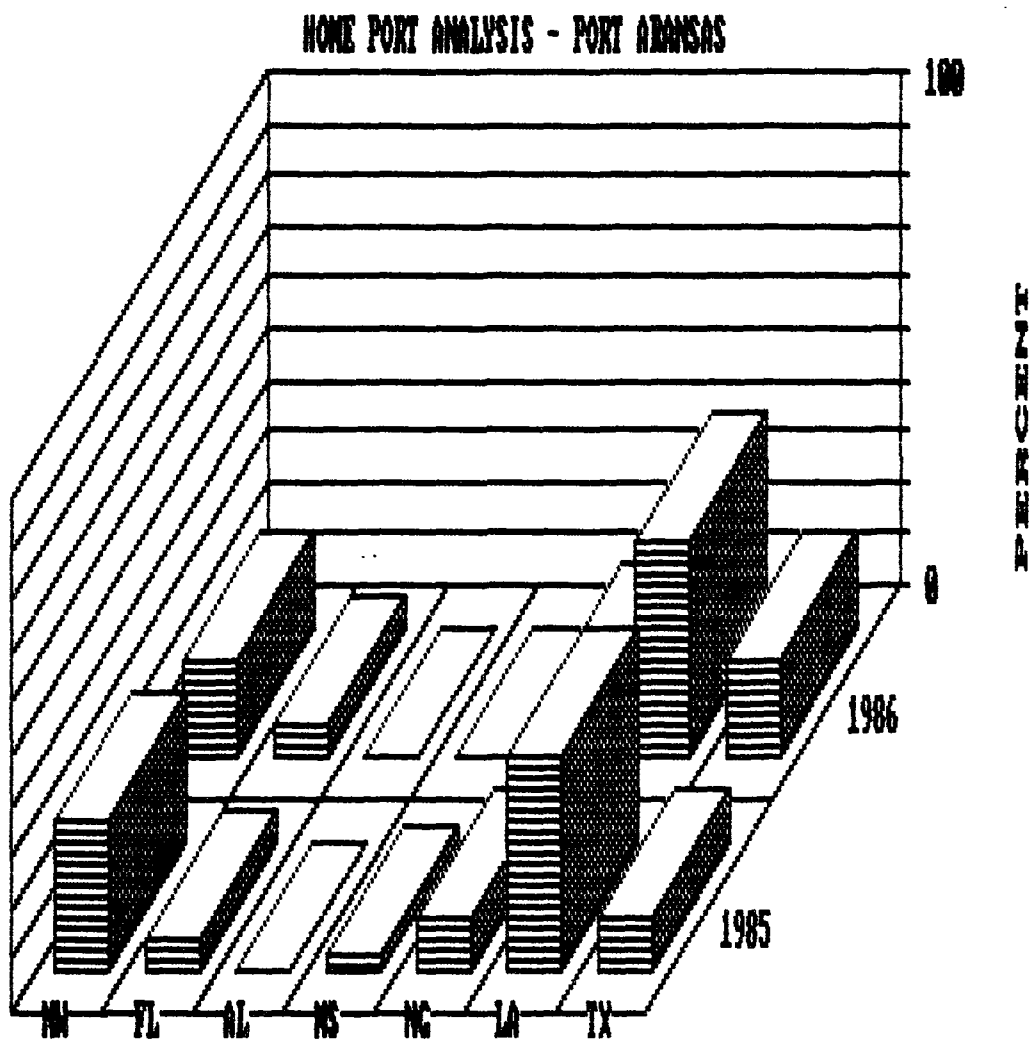

Figure 52. Determination by percentages of where interviewed captains with a home port in Port Aransas, Texas, fished for shrimp, if they did, during the 1985 closure period and the 1986 closure period. (NW = didn't fish for shrimp; FL=Florida; AL=Alabama; MS=Mississippi; NG=Northern Gulf of Mexico; LA=Louisiana; TX=Texas).

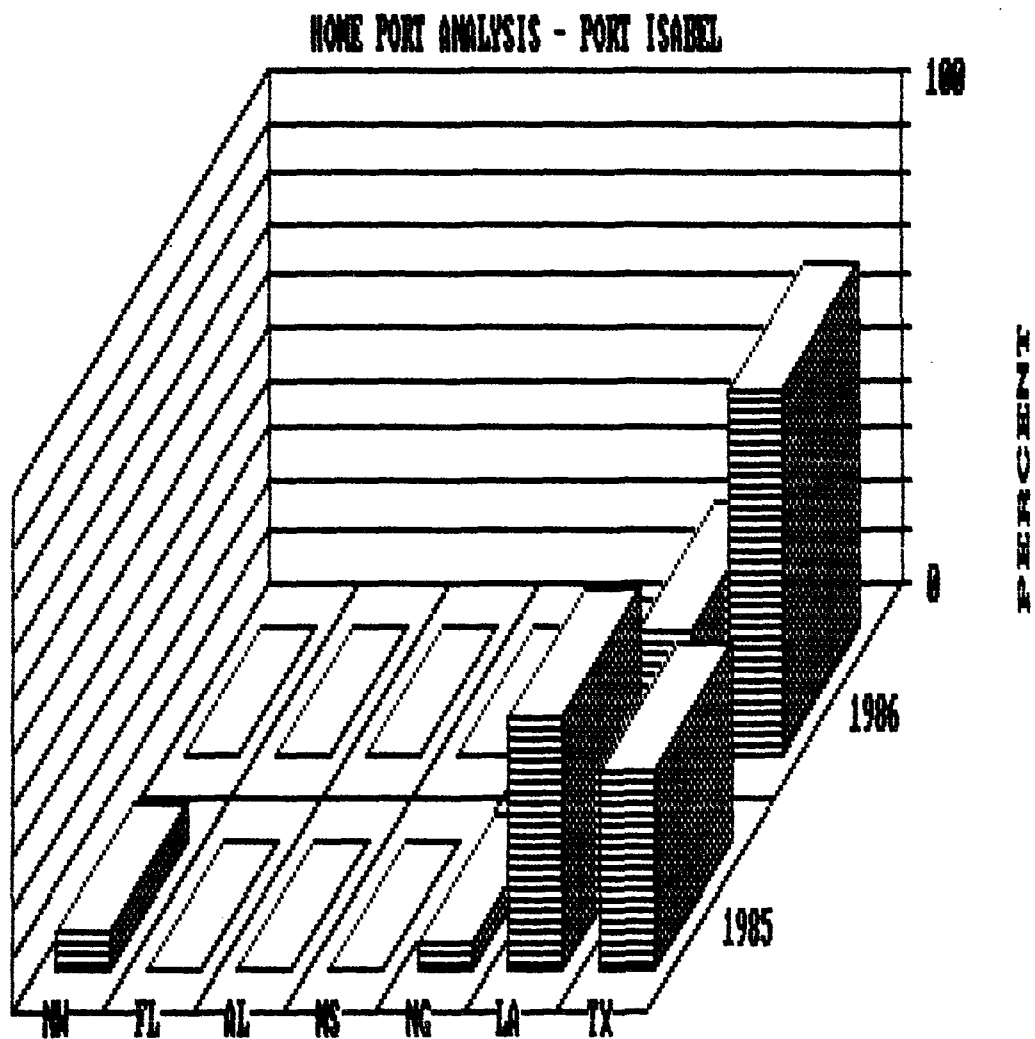

Figure 53. Determination by percentages of where interviewed captains with a home port in Port Isabel, Texas, fished for shrimp, if they did, during the 1985 closure period and the 1986 closure period. (NW = didn't fish for shrimp; FL=Florida; AL=Alabama; MS=Mississippi; NG=Northern Gulf of Mexico; LA=Louisiana; TX=Texas).

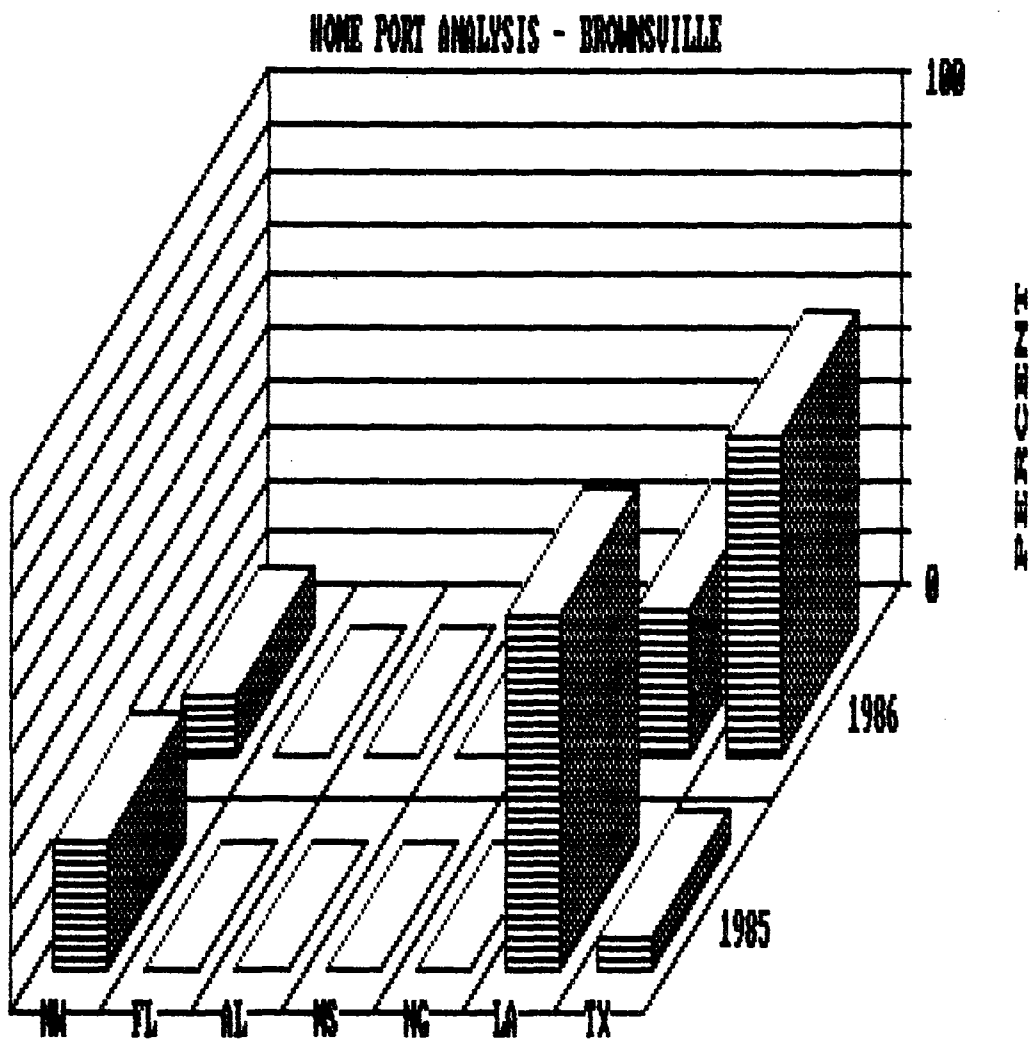

Figure 54. Determination by percentages of where interviewed captains with a home port in Brownsville, Texas, fished for shrimp, if they did, during the 1985 closure period and the 1986 closure period. (NW = didn't fish for shrimp; FL=Florida; AL=Alabama; MS=Mississippi; NG=Northern Gulf of Mexico; LA=Louisiana; TX=Texas).

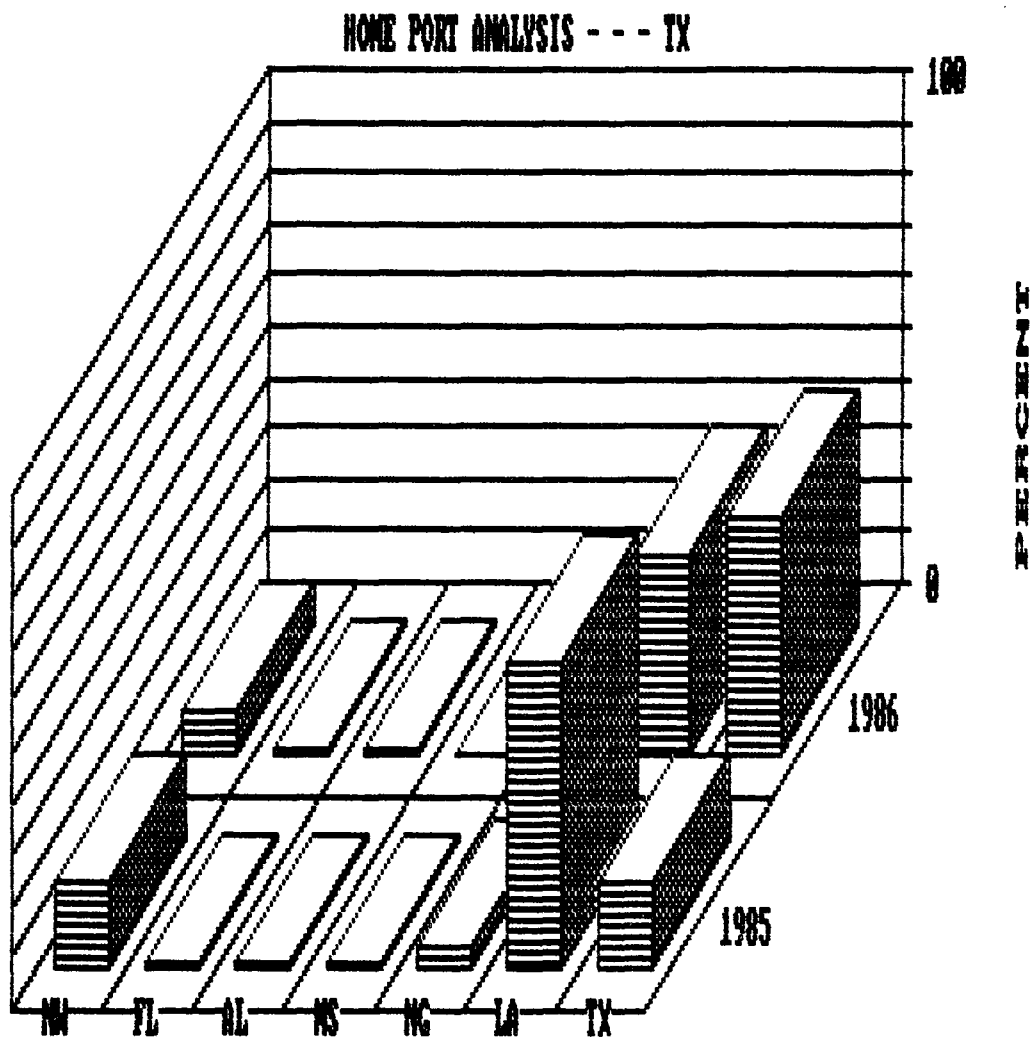

Figure 55. Determination by percentages of where interviewed captains with a home port in Texas fished for shrimp, if they did, during the 1985 closure period and the 1986 closure period. (NW = didn't fish for shrimp; FL=Florida; AL=Alabama; MS=Mississippi; NG=Northern Gulf of Mexico; LA=Louisiana; TX=Texas).

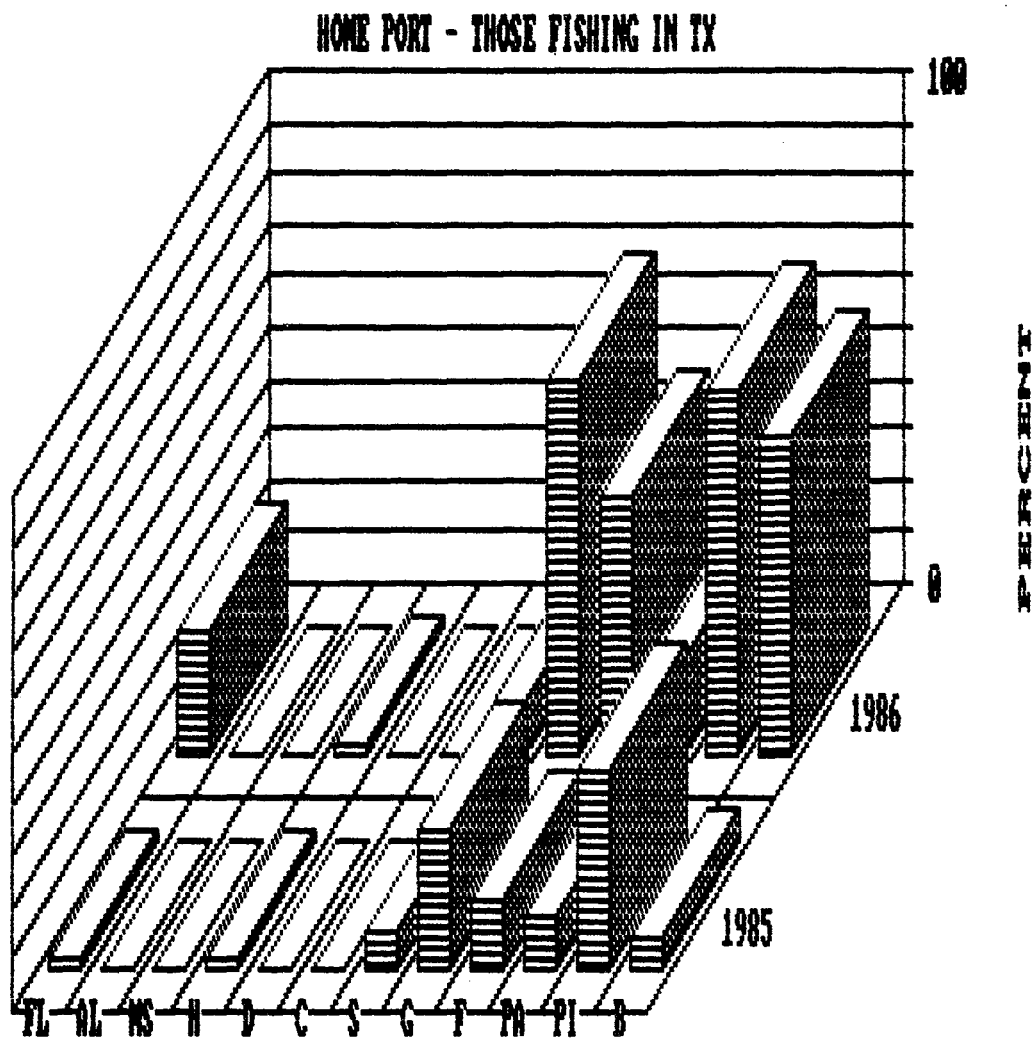

Figure 56. Percentages of captains from various ports who fished off Texas during the 1985 closure and/or the 1986 closure (see Figure 38 for port legend).

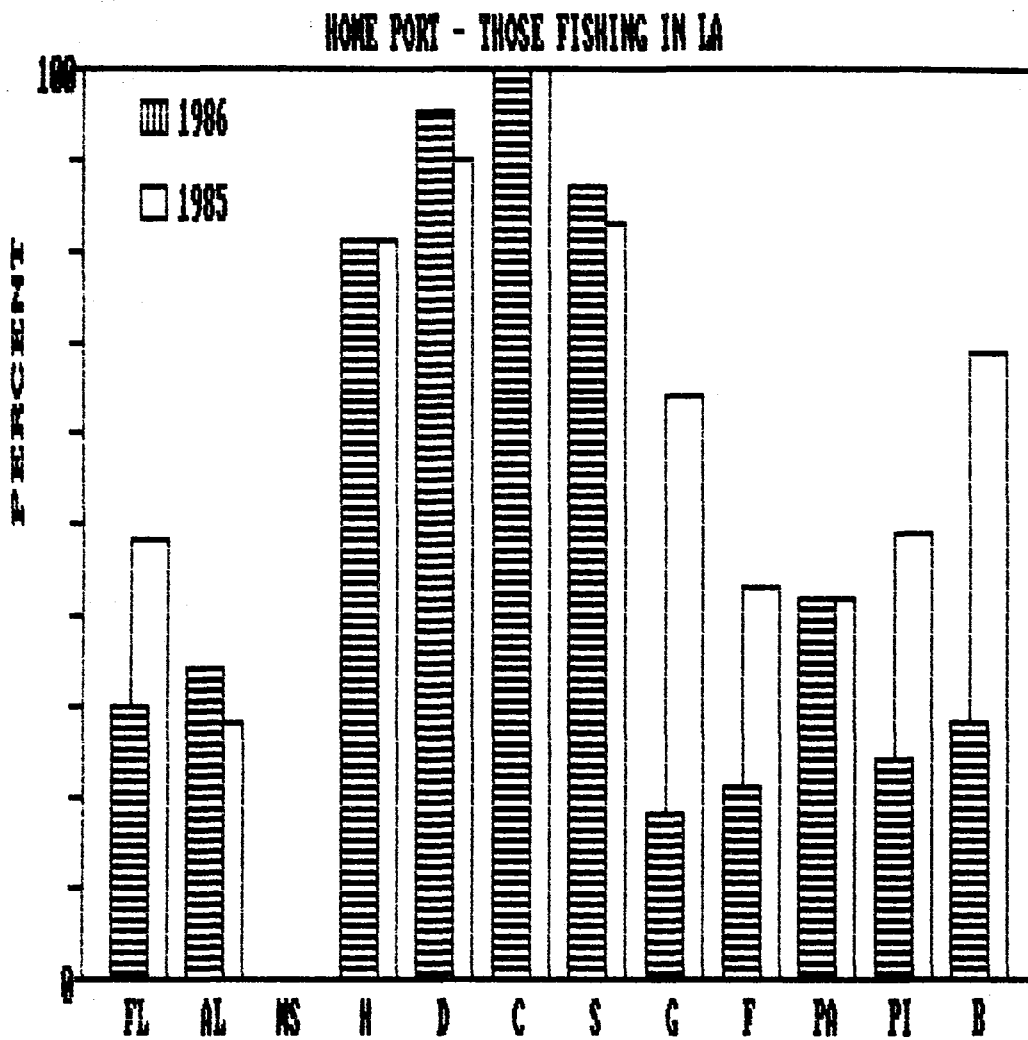

Figure 57. Percentages of captains from various ports who fished off Louisiana during the 1985 closure and/or the 1986 closure (see Figure 38 for port legend).

## APPENDIX

Comments about the FCZ closure off Texas from captains interviewed with the social form. Comments are grouped by fishing port (interview port).

Ft. Meyers, FL Interviews

CON

Hasn't done any good.  
Unnecessary. No good due to lack of enforcement.  
Don't think should have it at all.

No Opinion

No opinion. Don't care one way or the other.

PRO

Ok but enforce strictly.

Bayou La Batre Interview

CON

Don't like it because of price controlling. When the areas open and you catch some shrimp the dealers drop the price.  
If they are going to close it, close it to everyone and enforce it.  
I do not agree with the closure, it doesn't benefit the commercial fisherman.  
Let Texas operate it. The Federal government does not need to be involved.  
Let Texas decide if it should open or close.

No Opinion

Not familiar with the Texas Closure, have not fished Texas in 20 years.  
I haven't fished Texas in a long time and don't care what they do.  
I don't fish Texas and don't want to tell them what to do with their shrimp since it doesn't concern me.  
I don't fish Texas and don't know about the closure.

PRO

Should close it. Let the shrimp get bigger before they are caught.  
I think they ought to close it out to 200 miles.  
I think it's a good plan. The shrimper can make more money when their catch is a bigger count size.  
It worked good when the laws were enforced.  
It's a good idea, the shrimp should be allowed to grow more before they are caught.  
It should be closed to 200 miles - let the shrimp grow up.  
I think it's a good idea to let the shrimp grow to a larger size before you catch them.  
Its bad for the home boats, but good for the others. I made good money in Texas the last 5 years but did not fish there this year - not enough shrimp to go there this year.  
I think we should close areas where the small shrimp are and let them grow.  
Should close waters until shrimp reach 31/35 tails.  
I think the closure is good for the commercial shrimper.  
Should open waters to shrimping when they reach legal size.  
I'm for the closure, including closing waters to bait shrimpers, too.  
I think it worked better by closing out to 15 miles rather than 200 miles, when the shrimp are out 15 miles they are a marketable size anyway. Also more law enforcement is needed along the Texas-Louisiana border.  
Texas and Federal waters should be closed until the shrimp grow up. The closed areas need to be patrolled better.  
I think it should have been operated like the last several years, we didn't have enough notice this year.  
I think it's a bunch of crap the way they handled it this year. It should have been like the other years.  
A good idea. Give the shrimp time to grow.  
I think it hurts the Texas shrimpers and forces the shrimper to concentrate in the opened areas. However, it is a good idea to let the shrimp grow

Bayou LaBatre Interviews continued

before catching them.

I think it's good to close areas where the small shrimp are. That includes closing to bait shrimpers and weekend warriors too!

I think areas where small shrimp are should be closed to everyone and keep it closed until they are grown.

Pascagoula Interviews

CON

Makes more competition in LA & MS as fishermen come here - especially Vietnamese.

May help Texas but only causes more fishermen this way.

It makes more fishermen come over this way and we got too many now.

No Opinion

No opinion.

No comment. Never fish Texas waters.

Never worked Texas - no thoughts about Texas closure.

Don't know.

Don't know.

No idea.

Nothing.

Don't know.

Nothing.

Don't know.

Doesn't know anything about it.

Don't know.

Don't know.

Don't know.

No opinion - if they want it they can have it.

Don't know.

Don't know.

Haven't really thought about it.

Don't really know.

Never really thought much about it.

Don't affect me one way or another.

Don't really know.

Didn't know it was closed.

PRO

Moneywise it should help with larger shrimp, otherwise no opinion. Don't go to Texas.

If shrimp big enough it should be open.

It should be a good thing if they do it right.

It is good if it keeps the small shrimp from being caught.

Houma Interviews

CON

It doesn't help - there are too many boats here.

Too many boats.

Too much competition with LA trawlers.

Too many boats.

Too much competition.

It puts too much pressure on LA trawlers.

Keep Texas waters open. Keep Texas vessels there.

Texas boats should stay in Texas, LA boats should stay in LA.

It puts more boats in LA waters when Texas is closed.

Puts too many Texas boats in LA when it is closed.

Too many Texas boats in this area when closed.

Texas boats stay in Texas, LA boats in LA.

The outlaws make their season before it opens. Benefit the outlaws not the people that obey the laws.

No good for fishermen only good for business people.

No good because do not open season at right time and do not let you know when season is opening far enough in advance. Say one date then open it on another date.

Not working dates right. Opening too early - shrimp are still small, not fulfilling their purpose.

Should stay open all year.

Don't like it.

Not good. Not much shrimp.

It's not really closed because single riggers trawl until they are stopped and warned then sell their shrimp as bait.

No Opinion

No comment.

No opinion.

No opinion.

No comment on Texas Closure.

No comment on Texas closure.

No comment.

Texas licenses too expensive.

No comment - always stay in LA waters.

No comment.

No comment.

No comment.

PRO

Helps trawler if watched closely and ticketed.

Doesn't matter when Texas waters are closed they just fish there when it opens.

Close 200 miles out, likes closure.

Delcambre Interviews

CON

Makes no difference to me personally; might cut down on TX boats in our area if TX opened.

Should be stopped.

Should be left open year round to keep TX shrimpers from fishing LA waters as much.

Should leave it open and stop TX boats from coming over here.

Don't fish in TX but opening it might cut down on the number of boats over here.

No Opinion

No comment.

No comment.

Don't work in TX waters, so I couldn't say.

Don't care as long as they don't close LA.

No comment.

No comment.

No comment.

Don't care as long as they leave LA alone.

No opinion.

No opinion.

No opinion. Don't fish in TX.

Don't fish in Texas waters.

Don't know about it.

No opinion.

Don't fish in Texas.

Don't fish in TX but seems like they're doing okay with it.

Don't fish in Texas so it doesn't matter to me but I've heard some people say it's not being enforced very well.

Don't care.

Don't know - only fish in LA.

Only fish in LA.

PRO

Should be closed all the way out and enforced equally, including immigrants.

I think it's a good thing; should close LA also to let shrimp grow more.

Sounds pretty reasonable; might do LA some good to do it too.

Should be continued and enforced.

Should be left completely open or completely closed; too hard to enforce otherwise.

Cameron Interviews

CON

Leave open!  
Don't want it to continue. Like it much better this (this years) way.  
Don't like it. Want it open.  
Dislike.  
This is okay so long as everyone does the same thing. Don't like all the boats coming here while TX is closed.  
Think they should keep open.  
Stupid.  
Think government should leave things alone.  
Think should leave open.  
Don't close.  
I think they should leave open, this year was better than closing entirely.  
Close everything if they close TX, should close entire Gulf.  
Don't like it, it's a rip-off.  
Don't like it at all. The prices drop.  
Don't like it. Too many TX fishermen here. Already overfished with just LA fishermen.  
Sometimes likes it, sometimes doesn't. Puts too many TX boats in LA waters.  
But enjoy going to the (TX) opening. Even though this year it wasn't very good.  
Keep it open don't like coming to LA; it's too expensive.  
Tx should stay open because TX boats come over and deplete LA shrimp.  
Keep it open, don't like having to come to LA to shrimp.  
It sucks!

No Opinion

Some years it seems to be okay. This year it wasn't that great.  
Don't have an opinion.  
Don't really care - that's TX problem.  
Don't care.  
Doesn't care either way.  
No opinion.  
Don't have opinion since this is 1st year I've shrimped.

PRO

Think okay.  
Likes the way it was this year (1986).  
I like the closure. Keep closing it.  
Like it but enforce or don't have it. LA should do the same thing.  
Captain thinks that LA should do the same thing as TX.

Sabine/Port Arthur Interviews

Con

Does not like - too many boats in one place.  
Needs to be open - too many boats in one place.  
Should not be closed - boats get concentrated in one area.  
Should be open all the time.  
Bullshit.  
Thinks it sucks.  
Does not like it, "stupid".  
Does not like.  
Wants Gulf open.  
Does not like.  
Open.  
Does not like!  
Does not like - should be open.  
Does not like.  
Does not like. Wants it open.  
It is ridiculous.  
Does not like.  
Does not like.  
Does not like.

No Opinion

No opinion.  
Does not understand - little English.  
Does not care.  
No opinion (through translation).  
Does not know.

Pro

Likes.  
Good, should set a definite date to open.  
Good, but should have definite dates of opening & closing.  
Opened too soon this year. Closure is good.  
Closure good - goes to IA - should close all shallow (inshore) & offshore.  
Close it all.

## Galveston/Bolivar Interviews

### Con

It was better this year because you could at least make a little money.

Closure, however, drops prices - not good.

Don't like 200 mile closure. If anything, keep 15 mile closure.

Should do away with everything. But if not, keep the 15 mile closure but

ENFORCE THE DAMN LAW.

Liked 15 mile better than 200 mile. However, should do away with both since they interfere with shrimping. Have to travel away to get shrimp.

A joke. 15 mile closure not too bad but should do something to help the Texas fishermen such as closure to out of state boats and restrictions on Texas boats. But, still let them fish or have some advantage over out of state fishermen. Another bad thing about the closure is that when opening occurs, prices for shrimp drops, due to out of staters.

Should open it all up - wouldn't be so many out of state boats for competition.

Don't like it. Makes Texas shrimp so popular to other states after opening.

Therefore, Texas shrimpers don't make as much money as they would without the closure.

"Sucks" because they opened it too early. The white shrimp were already off the beaches and since they could only drag one net, they couldn't make enough money. Therefore, they had to move to other fishing grounds farther away (Louisiana).

As it has turned out, no shrimp, the closure is not working. Something else should be done or just open the thing up and leave it alone.

Haven't really thought about it. Since from Alabama, doesn't really affect him. However, thought that it did not really help.

Didn't really care because from Florida. But the closure failed in its purpose by the fact of fewer and smaller shrimp at time of opening.

Thought it sucked. Wanted it like to old time closure. 4 fath line to 10 miles during day and 7 fath line out during night.

Bullshit.

Closure doesn't work.

Should do away with it. Works better open.

Don't like it. Do away with everything. Can't make a living with the closure.

### No Opinion

Haven't evaluated yet.

Thought that they closed the waters a little too early.

Opened too soon. Shrimp just too small to make any money on.

### Pro

Good. Thought it worked well this year. 15 mile is a reasonable closure, since this is the area most sensitive to small shrimp.

200 miles bullshit. Takes 2 months off working time. 15 mile good because at time of closure, fishing 15 miles offshore anyway.

200 mile limit not good because it hurt local fisherman. 15 mile limit good though.

Galveston/Bolivar Interviews continued

Thought it was good or better this time with the partial closure.

Wasn't too bad this year.

Better this year, partial closure allowed more time to work and lowered  
outlawing.

Closure is a good thing. Both 15 & 200 mile closures are fine.

Liked it better last year, don't like 15 mile closure, no shrimp.

Closure not good because as it is, no shrimp in the gulf. Would rather have  
200 mile closure.

Don't like 15 mile closure, liked 200 mile closure better because it yielded  
more and bigger shrimp.

200 mile closure better. But for the thing to be good the law must be  
ENFORCED!

## Freeport Interviews

### Con

It would be fine if the other states would close too.  
Should not have a closed season unless close everything (Gulf).  
If going to close, close everything (Gulf).  
If going to close, close entire Gulf. The 15 mile did not cause a concentration of boats.  
Does not like closure season.  
Don't think they should close at all.  
Season closure should be open.  
Should be open.

### No Opinion

Opens 2 weeks later, and closes 2 weeks later.  
Closed too early and opened too soon.  
Don't know what to think about it.  
I think that the season opened too soon and enforce the law they have.  
Open too early, should have been 15th.

### Pro

If going to close, close out to 200 miles.  
Leave at 200 mile, enforce laws, take boats if break laws.  
Close from Buccaneer Field now Matagorda longer - closes off as far off as 12 to 13 fathoms off Freeport.  
Should be continued and expanded to include Louisiana waters to Mississippi River.  
Close everything. Sports, Bay, inshore.  
I think it would be alright if they would close bays too.  
If closed, close to all boats, small and large, allow shrimp to grow up and move out.  
Close inshore and offshore - total closure. No enforcement.  
15 mile offshore is alright.  
I like 15 miles, maybe 30 mile better.  
I like it like it is now - get boats off little shrimp.  
Wait until July 15 to open. No enforcement. I like 15 mile closure. Size limit on shrimp.  
I like 15 miles.  
I like the 15 mile closure better than any so far so there not be one sweep of boats and all the shrimp gone.  
I like 15 miles, do not open early May 30-July 15 - full time, game warden enforcement.  
Close like it is now, not 200 miles, too boats at one time when opening.  
The 15 mile closure is fine with me, but they opened too soon - shrimp were too small - control of laws.  
Ought to leave open outside of 15 miles.  
Don't think closed long enough - like 15 miles - controlled.  
I like 15 mile closure - closed entirely for 15 fath, no boats at all.

Port Aransas

Con

Bullshit.

Close all Gulf coast 200 miles out, close in May - open 7/15.

Crock of shit. Should have opened earlier to force the shrimp out to offshore waters.

Keep it open year 'round, no limits.

No advantage to it.

It sucks; need to close the bays (Texas waters) until shrimp are big enough to harvest.

Crock of shit, opened too early this year and shrimp were too small.

Not worth a damn, it opened too early and shrimp are too small.

No Opinion

Do not care, fishes in Louisiana.

Opened too early.

Most people do not obey it and shrimp there anyway, laws need to be enforced.

Keep non-state boats out, opened too early this year and shrimp were too small.

Pro

Leave it as is, wait until shrimp get larger to harvest.

All right, season was o.k.

The 15 mile limit is better than 200 mile limit, season opened too early.

It sucks, kept it like it was last year.

Close it back to 200 miles, open for 45 day period and close it then.

Stayed closed longer until shrimp were bigger.

Stay closed longer until shrimp are large enough to harvest.

Keep it closed longer so shrimp can get bigger to harvest.

Season should open later when shrimp are bigger.

Season should open later, keep it closed longer.

Need to keep it a 45 day open season and then close it.

Close it out to 25 miles until shrimp are big enough to harvest, close bays at same time as FCZ.

Close bays out to 15 fathoms mark, until shrimp are big enough to harvest.

Close everything out to 200 miles until shrimp are large enough.

Needs to be closed out to 200 miles, including bays until shrimp are big enough.

Close bays at same time as FCZ and out to 200 miles.

Close it from bays to 200 miles out from May to 7/15, keep out of state boats.

Keep limits uniformed from bays to 200 miles especially breeding grounds i.e. bay areas.

Pt. Isabel Interview

Con

This year it was opened too soon. 200 or 15 miles is not working. Should go back to closing only 10 miles - keep the rest open because production is better.

Should open from 10 miles out - this gives us an opportunity to catch the shrimp before it goes to Mexico.

No good. The closing and opening dates are not good for the fishermen. The shrimp goes to Mexico. This year the closing was too early and opened too soon because there is still lots of small shrimp being caught.

Should not be closed so we can work all year. Don't close it - it is our livelihood.

Keep it opened all year round or go back to closing it only 10 miles.

It shouldn't be closed because it forces us to go to IA and the shrimp is too small and we don't make any money.

Should be kept opened so we can fish year-round so that I won't have to ask for food stamps.

You have nor right stipulated by the law to close Texas waters. There is no law that allows you to close the waters. The 200 miles was made for military purposes only. It has not done any good. You are interrupting mother nature's cycle of production. The only way the shrimpers are going to survive is to get permission from Mexico to fish their waters. You should change the trawling season for bay boats because they kill lots of small shrimp. From 1965 to 1970 fishing trawlers had 2 nets. There were fewer boats, but the catch season was great. You could get 50 boxes a night. Now there are boats that have 4 nets, they trawl 50 miles of territory on a night leaving less production. The production is much less because there are more boats out there. I can't afford to pay the Lacey Act fine I was given.

Should be kept open completely all year round.

Should close for the 200 miles from Texas to Florida.

No Opinion

Closure was too early - no rain which helps shrimp.

Coast was opened too early. Every year the coast is closed too early and opened too early.

It was closed too early and opened too early. Shrimp was too small on the opening and it played out quick.

This year was bad on the part of NMFS.

Pro

Should be kept as this year 15 N miles - in case there is nothing in IA.

Keep it as this year so that we can fish here and not have to go to IA. I expect more brown shrimp to show up this year.

Closed too early and opened too early - keep it as today 15 miles closure so we can at least work this area.

I think it is good this year. Should be kept as this year (15 N miles closure only).

Should keep the 15 miles and get back the count law during closure.

Port Isabel Interviews continued

Keep as this year. 15 miles closure only because this allows us to fish the year round and we are able to make payments on our bills.

Keep as this year. 15 mile closure only. We are able to fish close to home and it is less expensive and we can fish the year round.

Should keep as this year - 15 mile closure.

Should go back to 200 miles because it gives the shrimp a chance to grow and it stops pouching.

Should close to 200 miles. We should be allowed to fish in Mexico. Coast Guard should not enforce the Lacey Act.

You screwed up this year. I think you should close it 200 miles. It lets the shrimp grow a little more. The 15 miles doesn't let it grow.

Should go back to 200 miles. This year it was closed too soon and opened too soon. This year it was the worst yet.

Should go back to 200 miles cause there is lots of pouching and it is not fair to us that obey the laws. The closure should be enforced more.

Should go back to 200 miles because it played out too quick this season.

Close it for 200 miles because there is lots of pouching going on otherwise.

## Brownsville Interviews

### Con

200 miles stinks.

It's better for me if they don't close to 200 miles. I will work (non-fishing job anyway but I want to know if there are going to be any shrimp.

### No Opinion

No real opinion on it. The closed season is not enforced - boats working inside limits every night unmolested. We need an enforced closed season. Why penalize 75% of the fishermen?

No good the way you got it, closed the season too fast. The shrimp wasn't small, then opened it too fast, should've held it 2 more weeks. The boats are just smashing the small shrimp, killing them & throwing them overboard. This is the worst I ever seen in since 1947. The 200 miles is better than what they did this year. Even no closed season would be better than the 15 miles then at least the price wouldn't be dropped as soon as there was the season.

### Pro

I think they done a good deal. A lot of those shrimp don't get to go south. We get to catch a little before they go south. We all made a little money. I like it better than the 200 miles when the shrimp just goes down south.

In my thinking, the 15 miles are better because one works more and there are less accidents. (Translated from Spanish).

The season was just 2 or 3 days then it slacked off. The only advantage the 15 miles is that its close to home and you don't have to run all the way to LA. If it was a good year 15 miles would be okay.

The 15 miles is better - make a mistake closed too early and opened too early - very, very small shrimp.

Lot better 15 miles than 200 miles, good to close coast so to give shrimp a little time to grow up. I sure don't agree with the 200 miles, no way to fish offshore of the 200 miles. A long ways to LA - need more fuel to go, but will fish over there if that's where the shrimp are.

Alright. 15 miles is fine.

The 15 miles was okay because there wouldn't have been any shrimp anyway if there had been 200 miles. The shrimp is still small; they should've left the season closed for a little while longer. Some good trips before the closure.

Not the 200 miles cause we don't have no chance to at least go out there and make a living. It is convenient to me - 15 miles.

Damn sure didn't do no good opening it to 15 miles - may as well be closed to 200 - to 10 miles it would be okay - don't move out till July or go on the Mexico.

The 200 mile limit was just perfect. What are they trying to do - make it easier during Oct-Dec so we can still make trips. 9-15-20 miles isn't right at all. The majority of the vessels are freezer boats. Those who want to go to LA - fine, go. Those who don't - fine, stay. Let's wait for the shrimp to grow to a better size, better price. The boats who go in and out every 3-4 days are the ones hurting the rest. Better catch last year after just waiting on the 200 mile closure.

Brownsville Interviews continued

They make a big mistake - lot of small shrimp still coming out from bay - wait till they grow up some - should have been closed longer. The 200 miles is better to let small shrimp grow up. Better to go to LA then come back - no one respects the coast, they say 15 miles but really fishing at 10-13 miles.

The 200 miles is better to let the shrimp go out because we're killing them. The 200 mile closure is better. Close for the future of shrimping. This survey is good and should be kept up to get everyone's opinion.

I think they ought to close it 200 miles and not have opened it so early this year.

I think I'm for the 200 mile closure now because those guys are just killing those little shrimp.

Helped a little but the season isn't that good this year. Honestly think it should be 200 miles because a lot of guys fish inside and it may be why we had a bad year.

Better to close 200 miles.

200 mile closure is better. Much better last year than this year.

200 miles is better. 15 mile closure means no shrimp.

Close the whole thing - 200 - 45 days that way nobody sneaks in and let the shrimp alone.

This year was too bad, I don't know why they do that (15 miles). The 200 would be better so when the season opens we could catch more.

I prefer the 200 miles because then they'll be shrimp all year long. With 15 miles it was just a 2 day season - it was 15 boxes the 1st night, 9 or 10 the 2nd and now it's already down to 2 boxes.

For me its better to close the 200 miles. There ain't nothing to this 15 miles, it ain't helping me. They catch that small shrimp too quick.

By far the worst season we've ever had in the shrimping industry. I prefer the 200 mile myself. We've always been doing better than this. I don't know why. The shrimps better if they're undisturbed.

The 15 miles stinks. They should've kept it the way it was - 200 miles. They just opened the season and there's nothing out there. Only 2 or 4 boxes/night. I hope they close it 200 miles next year. Last year was better.

The 200 mile closure was better because there was more shrimp but without as much shrimp the price stays better. Now there was just a steady harvest on them plus the closed season gives them a chance to spread out - at 15 miles everyone is fishing/scraping the line before they can get out.

I, \_\_\_\_\_, Captain of the \_\_\_\_\_, am of the opinion that it is better for the closure to be 200 miles - as long as there is good vigilance. Many of us fish in Louisiana during this time, but we are usually advised of the opening of the Texas fishing with very little advance notice and I think this is very inconsiderate toward the fishermen. As long as the smaller boats continue to fish in the lagoon during the closure the shrimp will not be permitted to grow. Thank you. P.S. Go ahead and open the closure when you think it is convenient, but please advise us 10-15 days in advance. All of us fishermen will be very appreciative of this. (Translated from Spanish).