

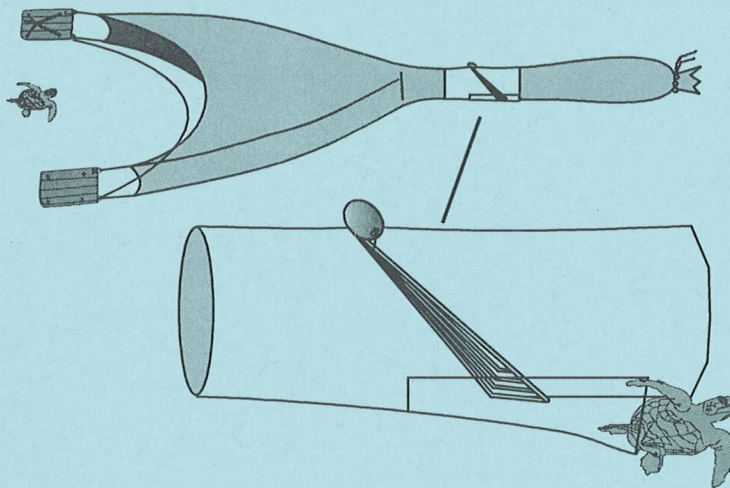

NOAA TECHNICAL MEMORANDUM NMFS - SEFSC - 366

THE TURTLE EXCLUDER DEVICE (TED): A GUIDE TO BETTER PERFORMANCE



April 1995

U.S. DEPARTMENT OF COMMERCE
NATIONAL MARINE FISHERIES SERVICE
SOUTHEAST FISHERIES SCIENCE CENTER
MISSISSIPPI LABORATORIES
PASCAGOULA FACILITY
P.O. DRAWER 1207
PASCAGOULA, MS 39568-1207

NOAA TECHNICAL MEMORANDUM NMFS-SEFSC-366

**THE TURTLE EXCLUDER DEVICE (TED):
A GUIDE TO BETTER PERFORMANCE**

BY

John F. Mitchell, John W. Watson, Daniel G. Foster, Robert E. Caylor

**U.S. DEPARTMENT OF COMMERCE
RONALD H. BROWN, SECRETARY
NATIONAL OCEANIC AND ATMOSPHERIC ADMINISTRATION
D. JAMES BAKER, ADMINISTRATOR
NATIONAL MARINE FISHERIES SERVICE
ROLLAND A. SCHMITTEN, ASSISTANT ADMINISTRATOR**

APRIL, 1995

This Technical Memorandum series is used for documentation and timely communication of preliminary results, interim reports, or similar special-purpose information. Although the memoranda are not subject to complete formal review, editorial control, or detailed editing, they are expected to reflect sound professional work..

NOTICE:

The National Marine Fisheries Service (NMFS) does not approve, recommend or endorse any proprietary product or material mentioned in this publication. No reference shall be made to NMFS, or to this publication furnished by NMFS, in any advertising or sales promotion which would indicate or imply that NMFS approves, recommends, or endorses any proprietary product or proprietary material mentioned herein or which has as its purpose any intent to cause directly the advertised product to be used or purchased because of this NMFS publication.

This report should be cited as follows:

Mitchell, John F., John W. Watson, Daniel G. Foster, Robert E. Caylor. April 1995. The Turtle Excluder Device (TED): A Guide to Better Performance. NOAA Technical Memorandum NMFS-SEFSC- 366, 35p.

Copies may be obtained by writing:

**National Marine Fisheries Service
Mississippi Laboratories
Pascagoula Facility
P.O. Drawer 1207
Pascagoula, MS 39568-1207**

**National Technical Information Service
5258 Port Royal Road
Springfield, VA 22161**

ACKNOWLEDGMENTS

The authors wish to thank the following people for their assistance in reviewing and editing this report, and for support and guidance.

**Dr. Brad Brown
Dr. Andrew Kemmerer
Dr. Scott Nichols
Wilber Seidel
Wendy Taylor
Dale Stevens
Jack Forrester
James Barbour
Dominy Hataway
Kendall Falana
Ian Workman
Sally Glynn
Colleen Coogan
David Bernhart
Suzanne Horn
Mark Johnson
Karen Raine
Jim Bahen
Dave Harrington
Jack Rivers
David Bankston
Dave Burrage**

We especially wish to thank the many fishermen, vessel captains, net shops and gear specialists who contributed to the information and technical expertise represented in this publication.

TABLE OF CONTENTS

Introduction	1
Matching TED to Fishing Conditions2
Construction Materials4
Top or Bottom Exit Hole?5
TED Angle.7
Checking TED Angle	9
Flotation11
Position and Size of Exit Hole.14
Accelerator Funnels17
Webbing Flap20
Chafing Webbing22
Roller Gear.24
Lazylines27
Deployment and Retrieval Tips.29
Maintenance and Troubleshooting.31
Soft TEDs33
Summary.35

Since the turtle excluder device, or TED, was first introduced to the U.S. shrimp fishery in the late 1980's, research and development to improve TED performance has continued. Using SCUBA divers and video cameras attached to shrimp trawls under actual working conditions, NMFS gear researchers working with shrimp fishermen and net shops have made improvements to the hard or rigid-style TED system, improving performance for both turtle exclusion and shrimp retention (Figure 1). Shrimp fishermen throughout the Southeastern U.S. have contributed to improvements in TED design and techniques for handling TEDs at sea.

The following information summarizes the latest advances in TED technology. Special emphasis is placed on methods of improving TED performance for shrimp retention. Where necessary, TED regulations are summarized for the particular topic being discussed.

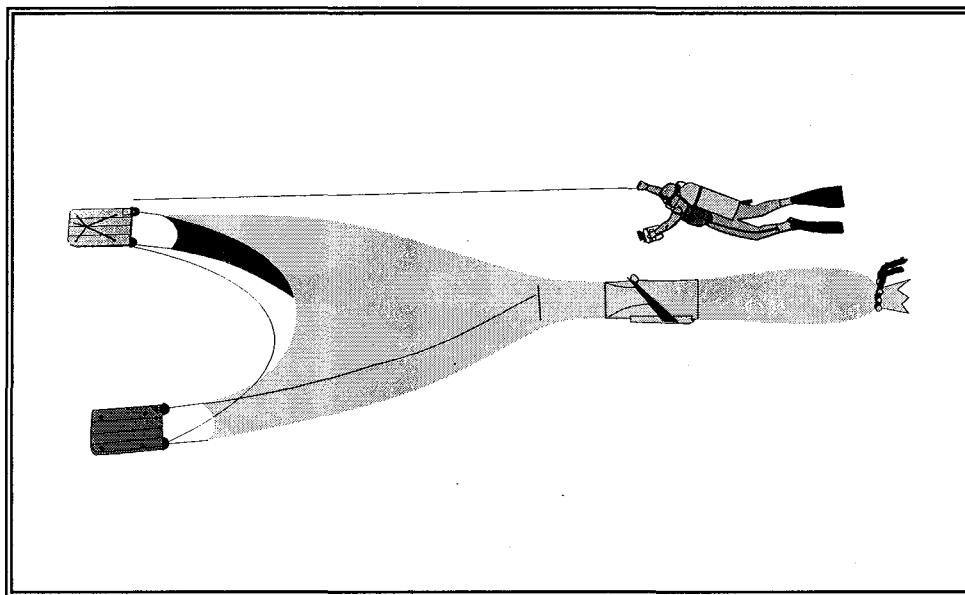

Figure 1 DIVER FILMING TED

MATCHING TED TO FISHING CONDITIONS

There are a variety of hard TED designs available to the fisherman today (Figure 2). To insure that each design will be efficient for excluding sea turtles, all must meet specific design criteria as described under federal TED regulations. These regulations specify such things as grid size, bar spacing and materials for TED construction.

The simplest of TED designs is the oval grid type, commonly called the Georgia-Jumper style. It is usually constructed from steel rod and features a horizontal cross brace for added strength.

Hooped TEDs have a circular or oval hoop on the front and or rear of the TED. Advantages to hooped TEDs are: 1.) usually of sturdier construction for fishing in rugged conditions and, 2.) the angle of the deflector bars remains fixed and cannot change as the trawl webbing stretches.

A fixed angle TED features a single hoop used to strengthen the TED frame and to maintain TED angle. The hoop and the deflector grid are sewn to the trawl extension in order to "fix" the angle of the TED in the trawl.

The Super Shooter (Reg. tradename) and Anthony Weedless (Patented) style TEDs are specially designed to reduce the accumulation of debris such as sea grass on the TED deflector bars, which can prevent shrimp from passing through the TED and into the tailbag. These TEDs are constructed of solid aluminum rod or pipe, and require little or no horizontal cross bracing. Each of these TED designs feature modified deflector bars to eliminate sea grass and other debris from the TED.

The flounder TED has been developed for use only in areas where flounder is the targeted catch. The 4-inch wide horizontal slots located at the bottom of the TED frame allow flounder and other fish to pass through the TED and into the tailbag of the net.

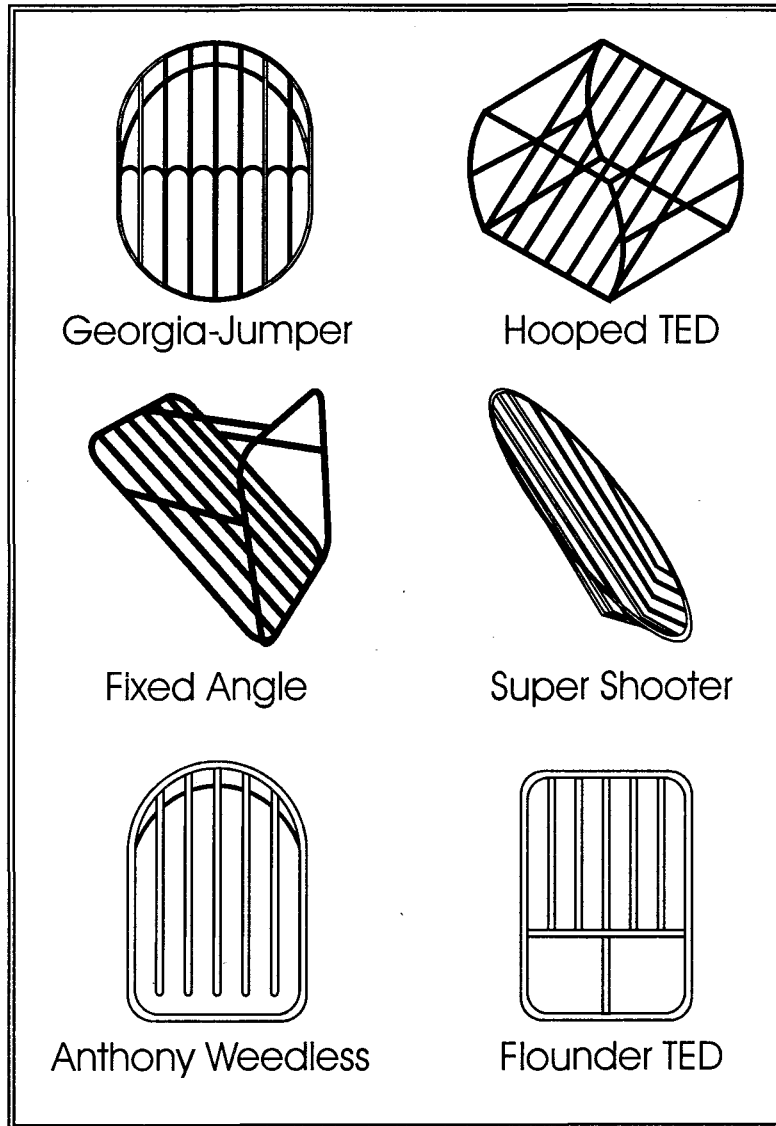

Figure 2 BASIC HARD TED DESIGNS

CONSTRUCTION MATERIALS

TED regulations specify that hard TEDs be constructed of solid steel rod, fiberglass rod, aluminum rod or heavy gauge steel or aluminum tubing . Regardless of the material it is made from, the TED should be built to withstand the rough conditions of sea going work.

TED REGULATION SUMMARY: CONSTRUCTION MATERIALS

A hard TED must be constructed of one or a combination of the following materials, with minimum dimensions as follows:

<u>MATERIAL</u>	<u>MINIMUM OUTSIDE DIAMETER</u>
Solid Steel Rod	1/4-inch - (0.64 cm)
Fiberglass or Aluminum Rod	1/2-inch - (1.27 cm)
Steel or Aluminum Tubing	1/2 - inch - (1.27 cm) (schedule 40 tubing)

TOP OR BOTTOM EXIT HOLE ?

Any hard TED can be installed with the turtle escape hole positioned at either the top or bottom of the TED frame (Figure 3). Both configurations exclude sea turtles, however, depending on fishing conditions there are advantages and disadvantages to each.

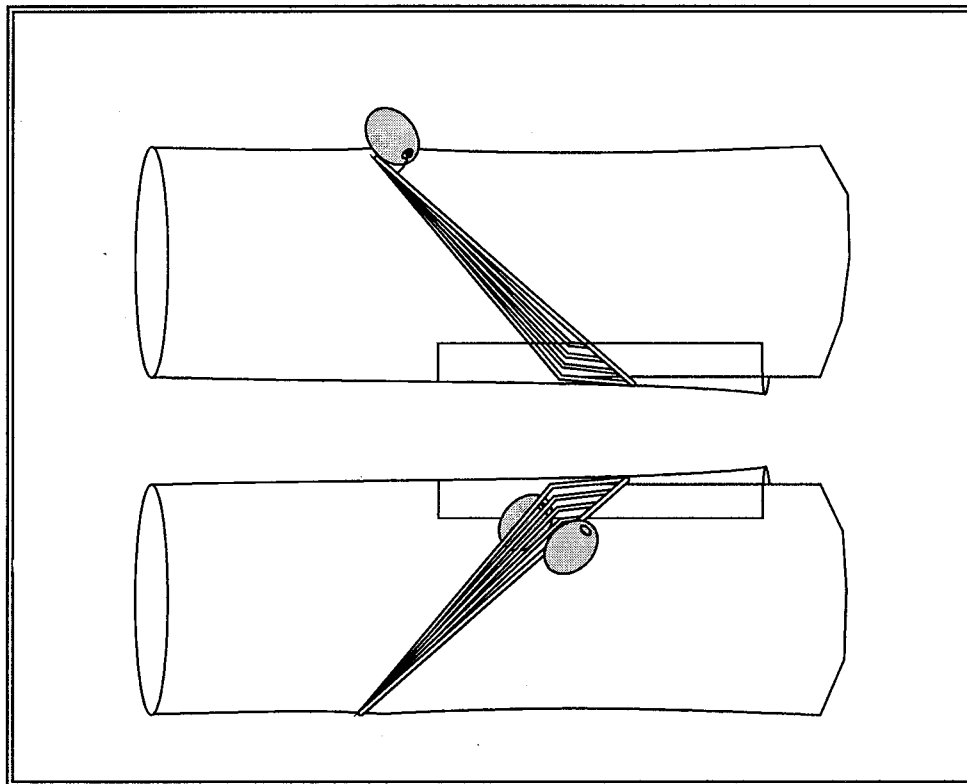

Figure 3 TOP AND BOTTOM EXITING TEDS

Shrimp fishermen have discovered that bottom opening TEDs can exclude debris from their catch such as grass, sticks, shell and sponge. Water flow and gravity assist the TED in sliding debris down the grid face and out the exit hole. In addition, unwanted bycatch such as jelly balls, sharks, and rays can also be excluded. Excluding debris and bycatch from the trawl can result in less damage to shrimp and faster sorting time on deck.

When trawling over an area that is relatively clean of debris, you may consider using a top opening TED. Due to the tendency of shrimp to be located near the bottom of the net as the water flow carries them to the tailbag, top opening TEDs can be more efficient in retaining shrimp than bottom opening TEDs. This has been documented through comparative tows of a top opening vs. a bottom opening TED aboard commercial shrimp trawlers.

TED ANGLE

The angle at which the TED operates during a tow is an important factor in preventing shrimp loss. TED regulations specify that all hard TEDs must be installed at angles between 30° to 55° from the horizontal (Figure 4).

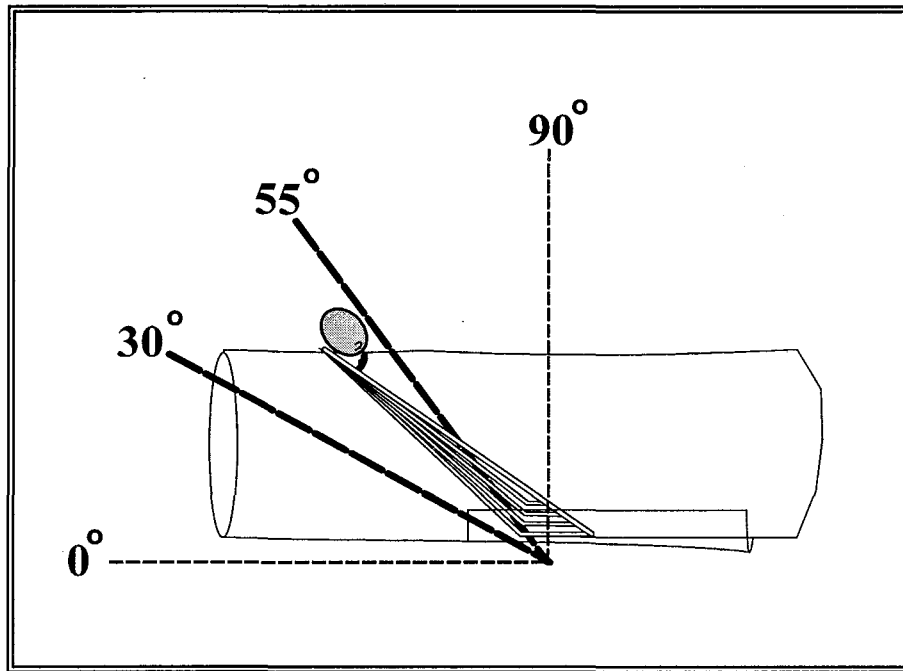

Figure 4 ALLOWABLE RANGE FOR TED ANGLE

TED REGULATION SUMMARY: TED ANGLE

The angle of the deflector bars must be between 30° and 55° from the normal, horizontal flow through the interior of the trawl.

Grid TEDs work best for turtle exclusion and shrimp retention when operating at a 45° angle. However, the TED angle can change over time due to stretching of the webbing extension around it resulting in an angle less than 45°.

A reduction in angle can occur with single grid hard TEDs when the TEDs are installed in new webbing, and the webbing knots tighten due to heavy catches or "muddying up".

If a TED is operating at an angle of less than 40° shrimp loss can occur due to diversion of water through the exit hole (Figure 5). TEDs which are operating at angles greater than 55° can prevent turtles from escaping, and trash will not slide down the deflector bars, resulting in clogging of the grid. Shrimp collect with the accumulated trash, and are discharged through the exit hole during haulback. When using a grid TED, which has recently been installed in new webbing, it is a good idea to check the grid angle after several days of fishing to insure it is between 40° and 55° . Whether the TED is new or old, the grid angle should be checked and, if necessary, reinstalled at the proper angle before fishing operations continue.

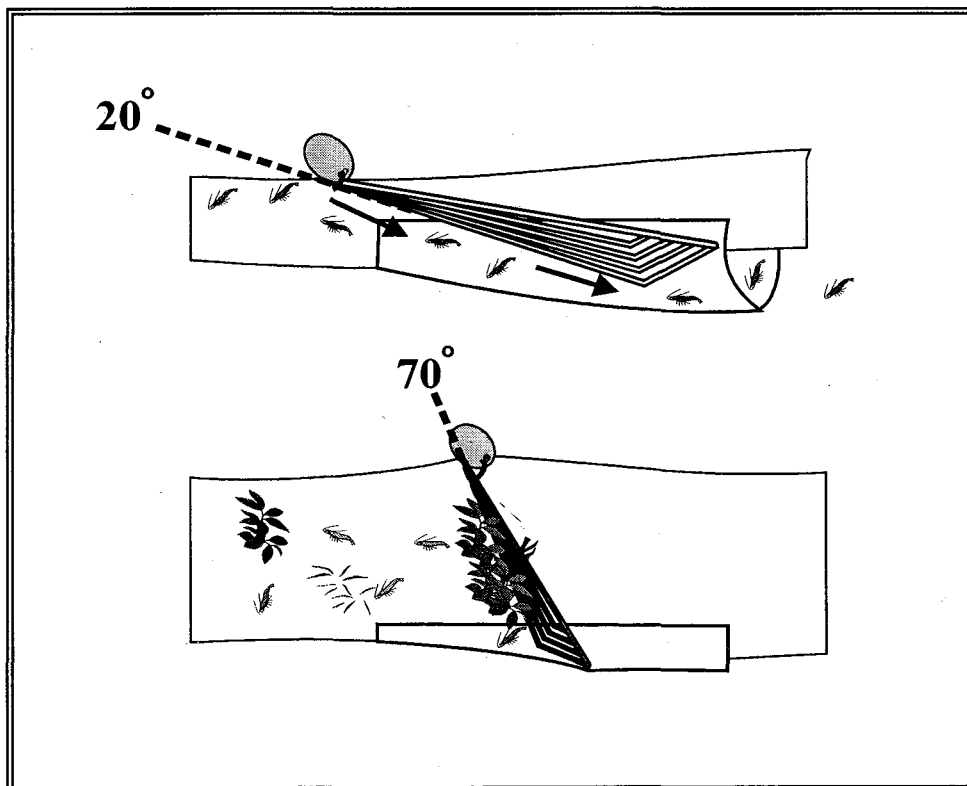

Figure 5 EFFECT OF ANGLE CHANGE ON TED OPERATION

CHECKING TED ANGLE

The recommended method for measuring the angle of the TED frame is described below. The method requires use of a standard carpenter's protractor, available at most hardware or lumber stores.

1. Using a trawl whipline, gather an even row of meshes around the trawl body located approximately 4-feet forward of the TED frame (Figure 6). Pull the whipline tight around the even row of meshes.
2. Using the whipline, suspend the TED frame approximately 4-feet off the deck.
3. Insure there are no twists between the TED frame and the whipline.
4. Insure the TED is hanging freely, and the tailbag is hanging directly under the suspended TED frame.
5. Insert the protractor (Figure 7) through the TED escape opening and place the correct side of the protractor against the surface of the grid bars. Read the angle of the TED (should be between 30° and 55°).

IMPORTANT:

Do not turn the TED toward you. Go to the escape opening. Turning the TED toward you will affect the angle of the grid.

Be sure you are reading the correct side of the protractor!

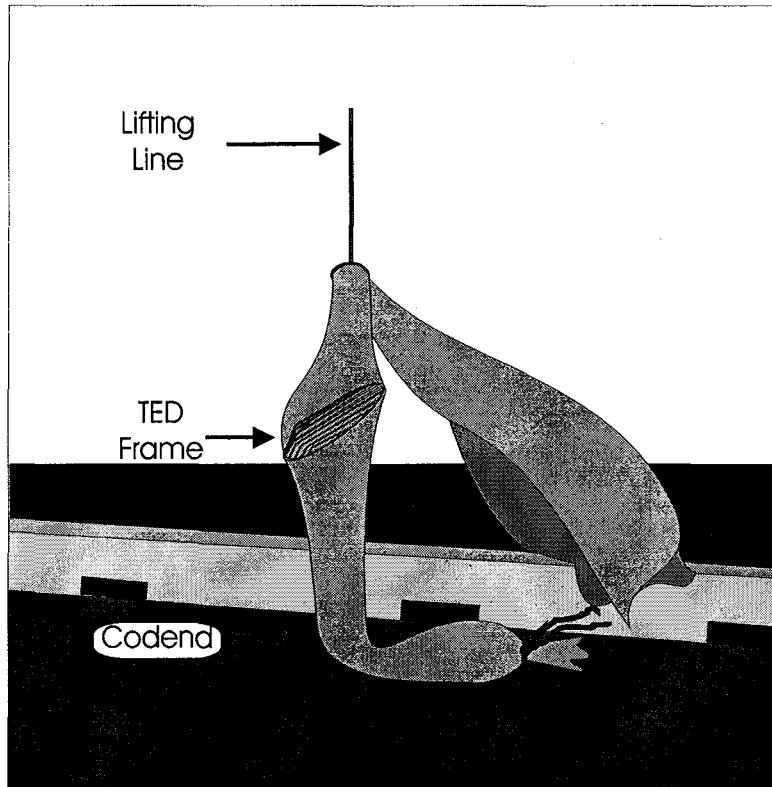

Figure 6 HANGING TED TO CHECK ANGLE

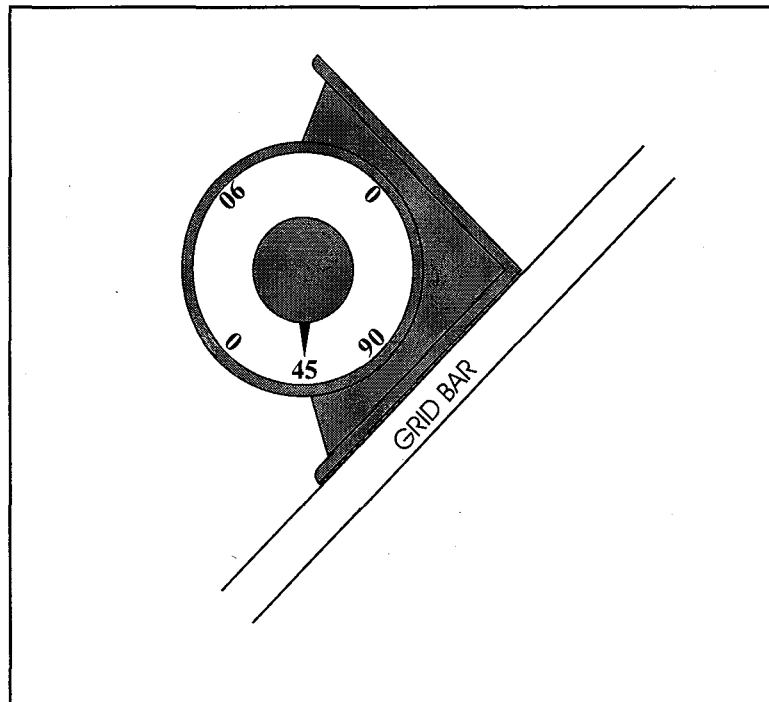

Figure 7 PROTRACTOR USED FOR CHECKING TED ANGLE

FLOTATION

Floats are an important component of any hard TED. Floats help stabilize the TED in the water and prevent it from rolling over during deployment or retrieval. More importantly, flotation insures that the TED will not chafe against the sea floor during operation thus preventing the need for mending and additional maintenance (Figure 8).

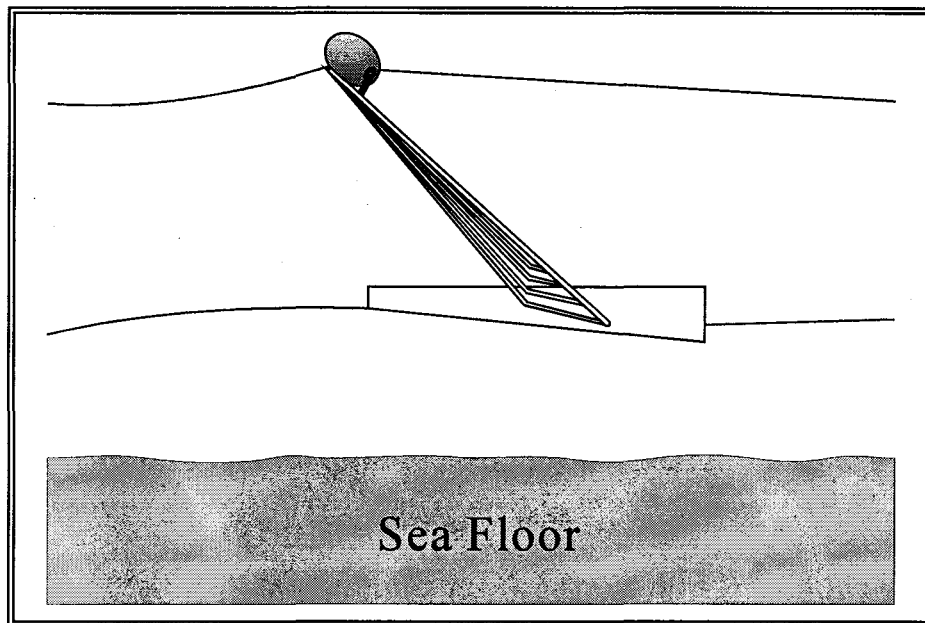

Figure 8 PROPERLY FLOATED BOTTOM OPENING TED

When a TED rides along the sea floor during a tow, it is not possible for debris to be discharged out the exit hole. The debris becomes trapped in the TED, causing an obstruction to the passage of shrimp. A properly floated TED should operate 18-20 in. (46-51 cm) off the sea floor.

Bottom exiting hard TEDs which are not properly floated have been shown to prevent juvenile sea turtles from escaping. For this reason TED regulations require that all bottom opening grid TEDs must have adequate flotation. Floats used on bottom opening TEDs must be constructed of expanded polyvinyl chloride (PVC), expanded ethylene vinyl acetate (EVA), aluminum (AL), or hard plastic (HP). The following table summarizes this requirement:

TED REGULATION SUMMARY: FLOAT RULE

If the TED circumference is less than 120 in. (305 cm), then:

Use one PVC or EVA float 6.75 inches (17.2 cm) in diameter by 8.75-inches (22.2 cm) in length

or

Use one AL or HP float 9.8-inches (25 cm) in diameter

or

Manufacturer stamped certified floatation equal to or greater than 10 lb (4.5kg)

If the TED circumference is greater than or equal to 120 in. (305 cm), then:

Use two PVC or EVA floats 6.75 inches (17.2 cm) in diameter by 8.75-inches (22.2 cm) in length

or

Use one AL or HP float 9.8-inches (25 cm) in diameter

or

Manufacturer stamped certified floatation equal to or greater than 20 lb (9.1kg)

If the TED is stamped with certified manufacturer weight, then:

Manufacturer certified stamped floatation equal to or greater than manufacturer certified TED weight

Fishing depth is also a consideration in properly floating a TED. When fishing in an area less than 10 fathoms (30 m), polyvinyl chloride (PVC) or ethylene vinyl acetate (EVA) floats are sufficient. When fishing deeper than 10 fathoms, hard plastic (HP) or aluminum (AL) floats should be used since foam floats will collapse and lose their buoyancy due to increased water pressure.

Floats must be attached to either the outside or inside of the net (Figure 9). Floats which are attached inside the net must be behind the TED frame, so as not to obstruct the passage of a turtle. No floats may be attached to the exit hole cover or flap of the TED.

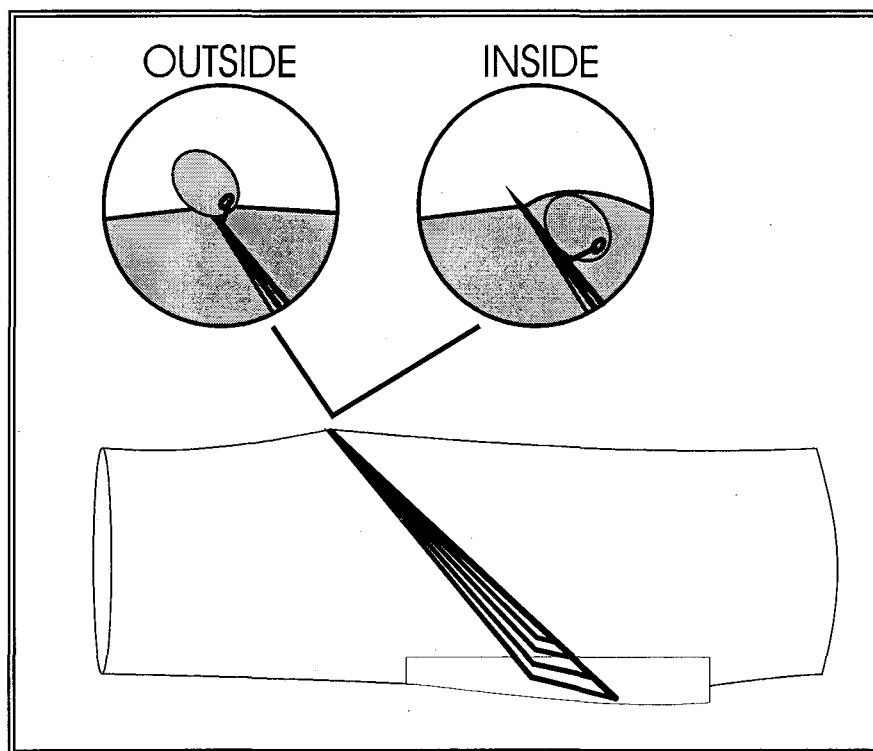

Figure 9 ALLOWABLE POSITIONS FOR FLOATS ON BOTTOM OPENING TEDS

POSITION AND SIZE OF EXIT HOLE

TED regulations specify the size and position of the cut in the trawl webbing which allows a turtle to exit the trawl. The cut must be centered on the top or bottom of the trawl (depending on whether your TED is a top or bottom excluder).

The minimum size of the cut or opening in the trawl webbing is dependent on the maximum width of the TED frame. The TED regulations summary indicates how the minimum size of this cut is determined. Figure 10 shows examples of exit hole cuts for two different grid sizes. Note that this requirement pertains only to the cut in the trawl webbing, and does not pertain to the exit hole cover or flap opening dimensions (to be covered later in this section).

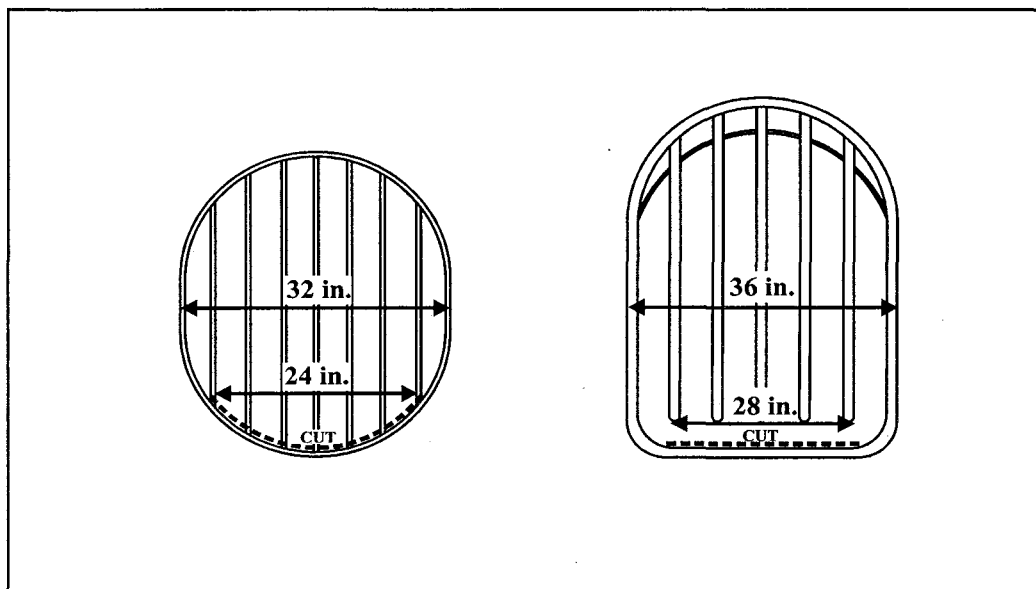

Figure 10 DIMENSION REQUIREMENT: EXAMPLES OF MINIMUM ESCAPE HOLE CUT FOR 32 AND 36-INCH GRIDS

**TED REGULATION SUMMARY: SIZE OF ESCAPE OPENING
(CUT IN TRAWL WEBBING)**

SINGLE-GRID HARD TEDS

The cut in the trawl webbing for the escape opening cannot be narrower than the outside width of the grid minus 8-inches (20.3 cm), when measured as a straight line width.

The dimensions of the exit hole opening at the flap is also specified and is specific for Atlantic and Gulf of Mexico waters (Figure 11).

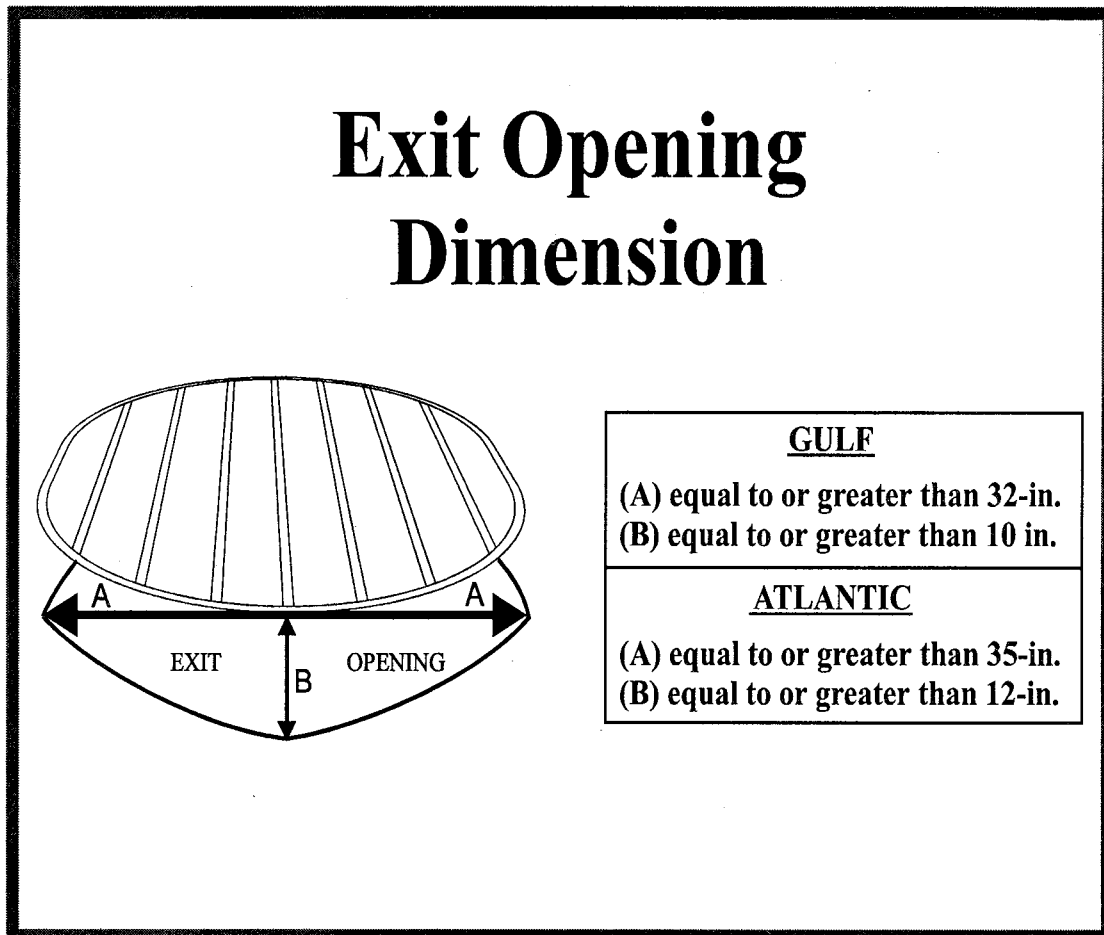

Figure 11 TED EXIT HOLE DIMENSIONS: ATLANTIC AND GULF

**TED REGULATION SUMMARY: SIZE OF ESCAPE OPENING
(FLAP MEASUREMENT)**

SINGLE-GRID HARD TEDS

The escape opening in the net webbing must measure:

Gulf of Mexico: At least 32-inches (81.3 cm) in horizontal taut length and, simultaneously, 10-inches (25.4 cm) in vertical taut height.

Atlantic: At least 35-inches (88.9 cm) in horizontal taut length and, simultaneously, 12-inches (30.5 cm) in vertical taut height.

NOTE: The vertical measurement must be taken at the mid-point of the horizontal measurement

HOOPED HARD TEDS

Gulf of Mexico: Must not be smaller than 25-inches by 25-inches (63.5 cm X 63.5 cm)

Atlantic: Must not be smaller than 30-inches by 30-inches (76.2 cm X 76.2 cm)

ALLOWABLE MODIFICATIONS

(Single Grid Hard TEDS)

ACCELERATOR FUNNELS

NMFS SCUBA divers, using water flow meters and dye injection techniques, have measured the water flow characteristics of an operating shrimp trawl. As the trawl is pulled through the water, an area of low water pressure develops under and behind it. This low pressure area produces a vacuum under the trawl that can actually draw shrimp out of a bottom opening TED which has an improperly fitted exit hole cover or flap.

One method of keeping shrimp away from the TED exit hole is to install an accelerator funnel. The function of the accelerator funnel is to direct shrimp away from the exit hole, and through the bars of the TED. Water and shrimp are accelerated through the funnel and past the deflector bars into the tailbag (Figure 12). Comparative trawling studies have shown that an accelerator funnel can significantly reduce shrimp loss through the TED.

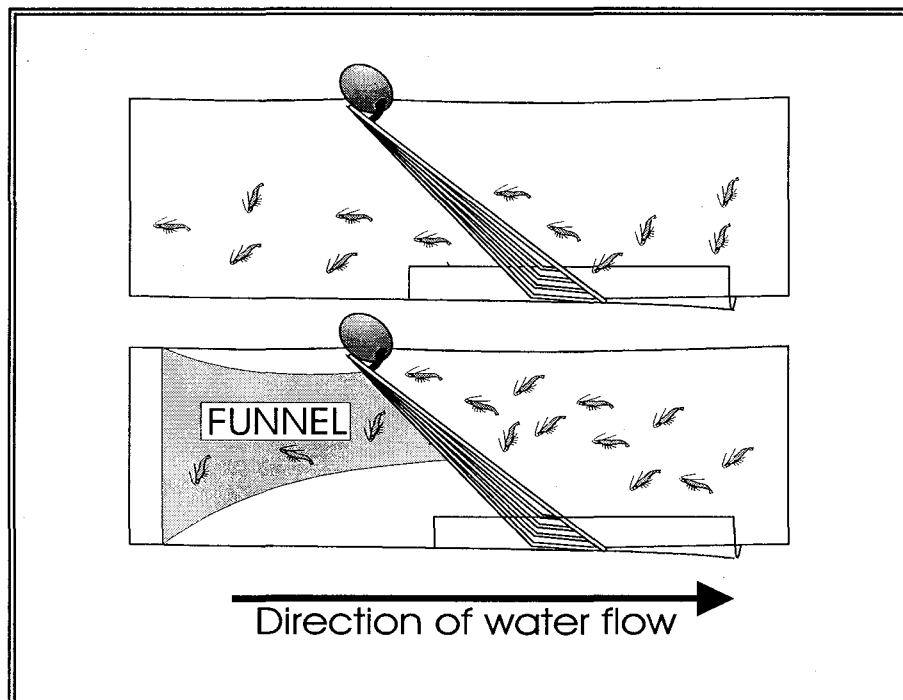

Figure 12 FUNCTION OF ACCELERATOR FUNNEL

To insure that large sea turtles will be able to pass through an accelerator funnel, federal regulations provide specifications on construction and installation.

In order to maintain an efficient funnel shape, and still yield the required opening, accelerator funnels should be constructed from depth-stretched and heat-set polyethylene webbing. This type of webbing has elastic properties, allowing the funnel to stretch in order to pass large objects, then returning to a closed mesh configuration. If heat-set poly webbing is not available an alternative funnel material is "used" bag webbing (nylon or poly) that has already been stretched. Dimension and requirements for accelerator funnels are described in Figures 13 and 14.

TED REGULATION SUMMARY: ACCELERATOR FUNNELS

- 1.) The tapered end of the accelerator funnel must open to a minimum diameter of 39-inches (99 cm) when stretched in a straight line configuration.**
- 2.) No more than 1/3 of the tapered end of the funnel may be attached to the grid. This attachment must be opposite the escape opening.**
- 3.) The maximum mesh size from which the funnel may be constructed is 1 5/8-inch stretched mesh.**
- 4.) The rear edge of the funnel may not extend past the TED deflector bars.**

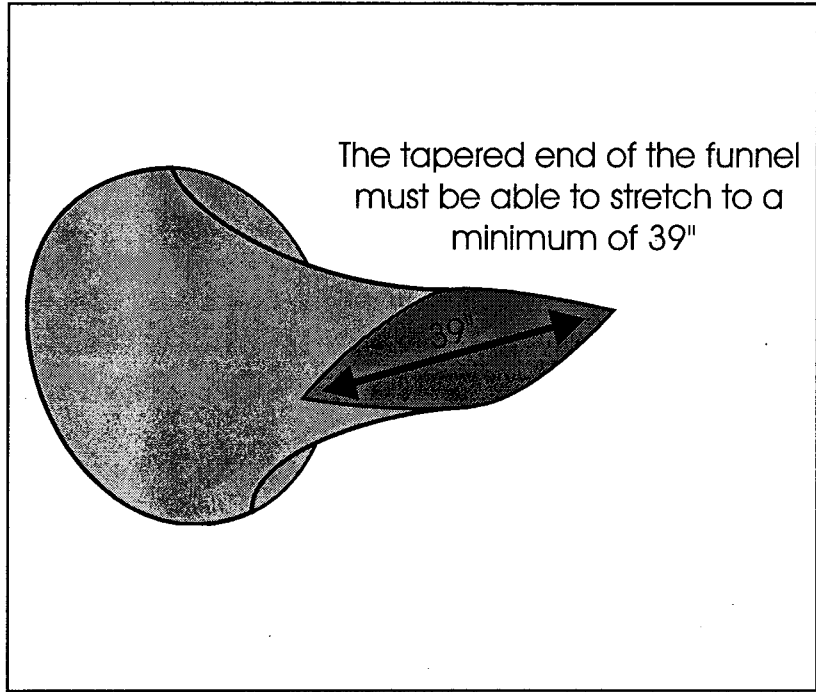

Figure 13 ACCELERATOR FUNNEL: MINIMUM DIAMETER MEASUREMENT

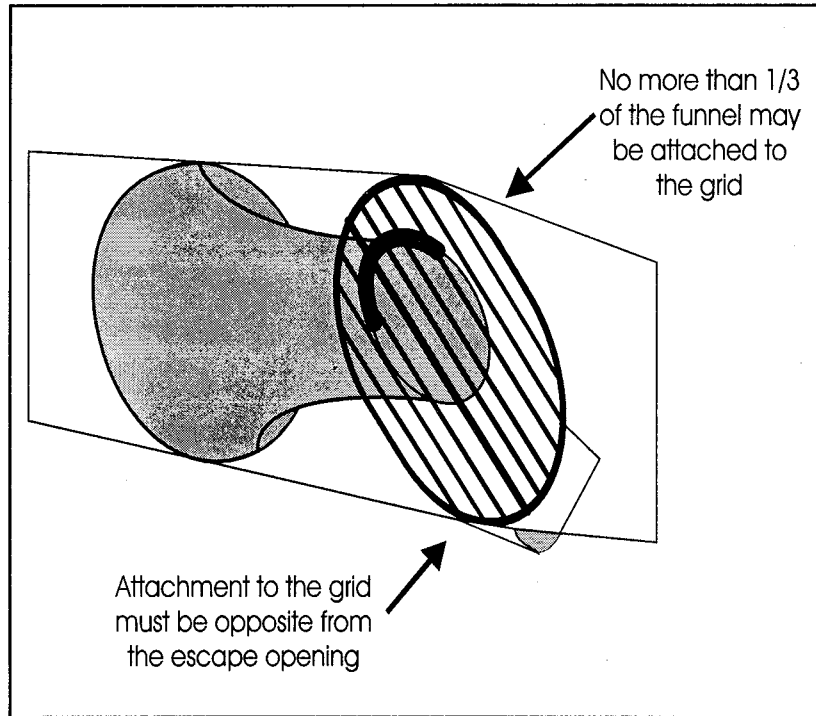

Figure 14 ACCELERATOR FUNNEL: GRID ATTACHMENT

WEBBING FLAP

Another important component of a TED is the exit hole cover or flap. A flap should fit over the exit hole during towing to prevent shrimp loss, yet open easily enough to allow sea turtles and debris to exit.

Most debris encountered during a tow will usually slide to the base of bottom opening TEDs. If not excluded from the TED, this debris can divert water flow and shrimp, out of the exit hole. A properly functioning bottom opening TED should exclude debris as quickly and as often as possible during a tow.

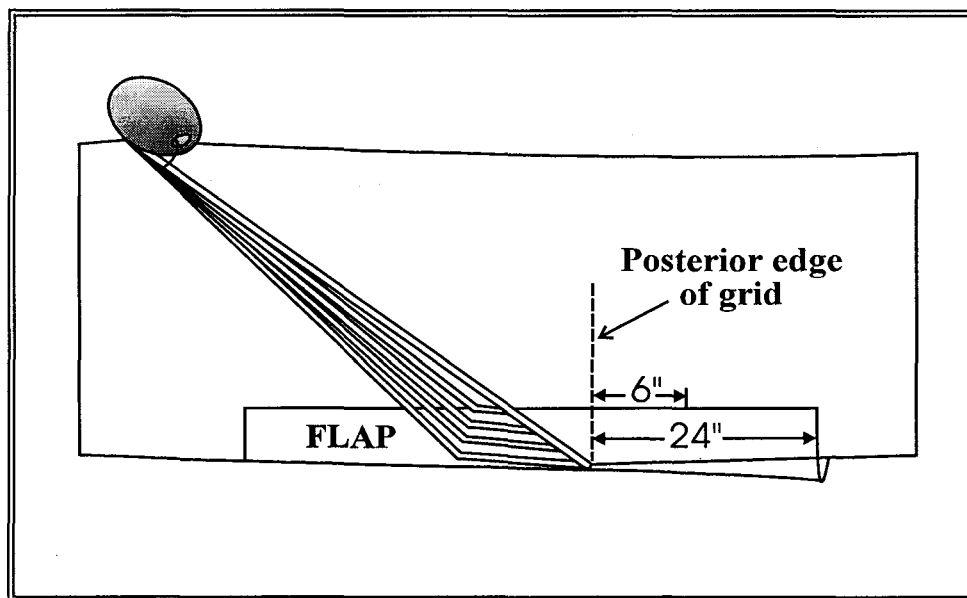

Figure 15 EXTENDED FLAP

NMFS gear researchers working with shrimpers have developed an exit hole and flap which can improve the ability of TEDs to exclude debris and retain shrimp. The "extended flap" can be adapted to any hard TED design (Figure 15).

The extended flap is made from heat-set and depth-stretched polyethylene webbing. A characteristic of this material is that it can return to its original shape after it has been stretched.

The flap extends forward of the TED frame and covers a large exit hole. The large exit hole is important, allowing the polyethylene webbing to stretch over a wide area in order to exclude large objects. Another feature of the extended flap is that it extends behind the TED frame and insures that the exit hole remains sealed when under tow.

Some captains prefer to use a short flap on a bottom opening TED. According to these fishermen, shorter flaps allow the TED to discharge debris more rapidly, reducing the possibility of clogging the TED. In addition, these fishermen report that a flap which has been shortened to leave a 4-inch opening at the base of the TED can result in a substantial reduction in fish bycatch.

TED REGULATION SUMMARY: FLAP LENGTH

A webbing flap may be used to cover the escape opening if no device holds it closed or otherwise restricts the opening, and if:

- 1.) It is constructed of webbing with a stretched mesh size no larger than 1-5/8-inch (4.1 cm).**
- 2.) Is attached along the entire forward edge of the escape opening**
- 3.) Is not attached on the sides more than 6-inches (15.2 cm) beyond the posterior edge of the grid.**
- 4.) Does not extend more than 24-inches (61.0 cm) beyond the posterior edge of the grid.**

CHAFING WEBBING

Another allowable modification on hard TEDs is the use of chafing webbing to reduce chafing on the bottom of the TED (Figure 16). Most chafing problems can be solved by providing additional flotation on the TED. But in some fishing conditions additional chafing webbing may be necessary. In order to insure that turtles can easily escape TEDs equipped with chafing gear the regulations require specific materials and installation techniques. A single piece of nylon webbing may be attached outside of the escape opening flap with the following specifications:

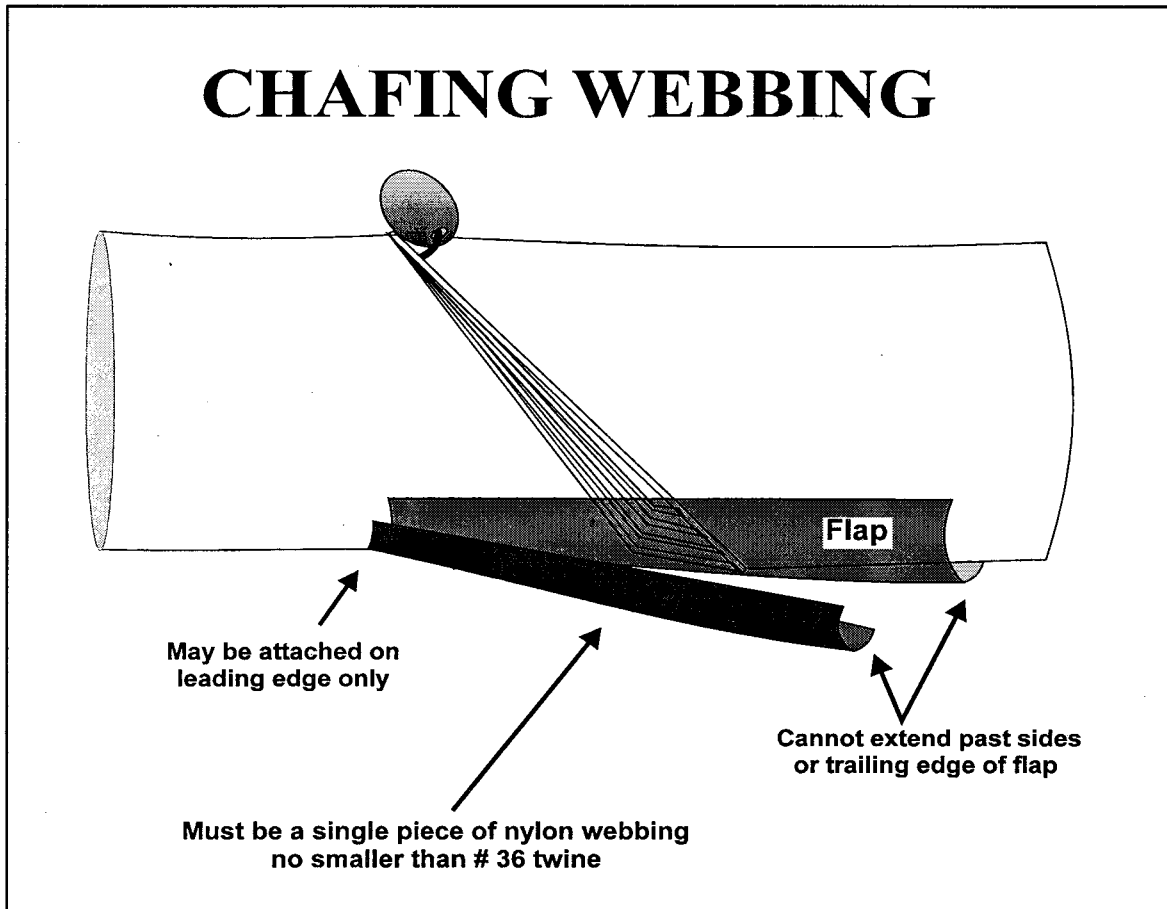

Figure 16 ALLOWABLE MODIFICATION: CHAFING WEBBING

TED REGULATION SUMMARY: CHAFING WEBBING

- 1.) It is constructed of nylon with a twine size no smaller than size 36 (2.46 mm in diameter).**
- 2.) May be attached along its leading edge only.**
- 3.) May not extend beyond the trailing edge or sides of the existing escape opening webbing flap.**
- 4.) Must not interfere or otherwise restrict the turtle escape opening.**

ROLLER GEAR

Roller gear developed by shrimpers on the Atlantic coast has recently been certified as an allowable modification to reduce chafing on single grid hard TEDs. When a webbing flap is used in conjunction with roller gear, the webbing flap must be of a length such that no part of the webbing can touch or come into contact with any part of the roller gear assembly or the means of attachment of the roller gear assembly to the TED, when the trawl net is in its normal, horizontal position (Figure 17).

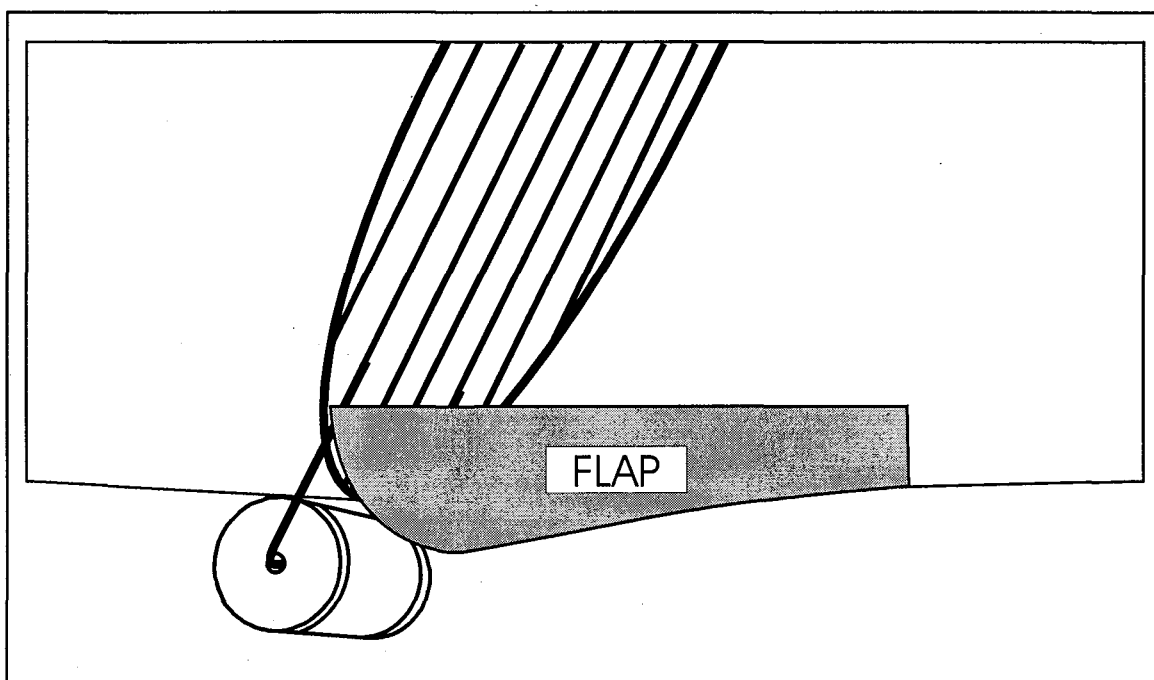

Figure 17 REQUIRED SHORT FLAP WITH PVC ROLLER GEAR

When roller gear is used it must be included in the circumference measurement of the TED or the total weight of the TED for required flotation requirements (see flotation section). Two roller designs have been certified for use; a single roller of hard plastic mounted on an axle rod (Figure 18), and a single roller or hard plastic tubing may be tied to the TED frame (Figure 19). Roller gear must meet the specifications described below.

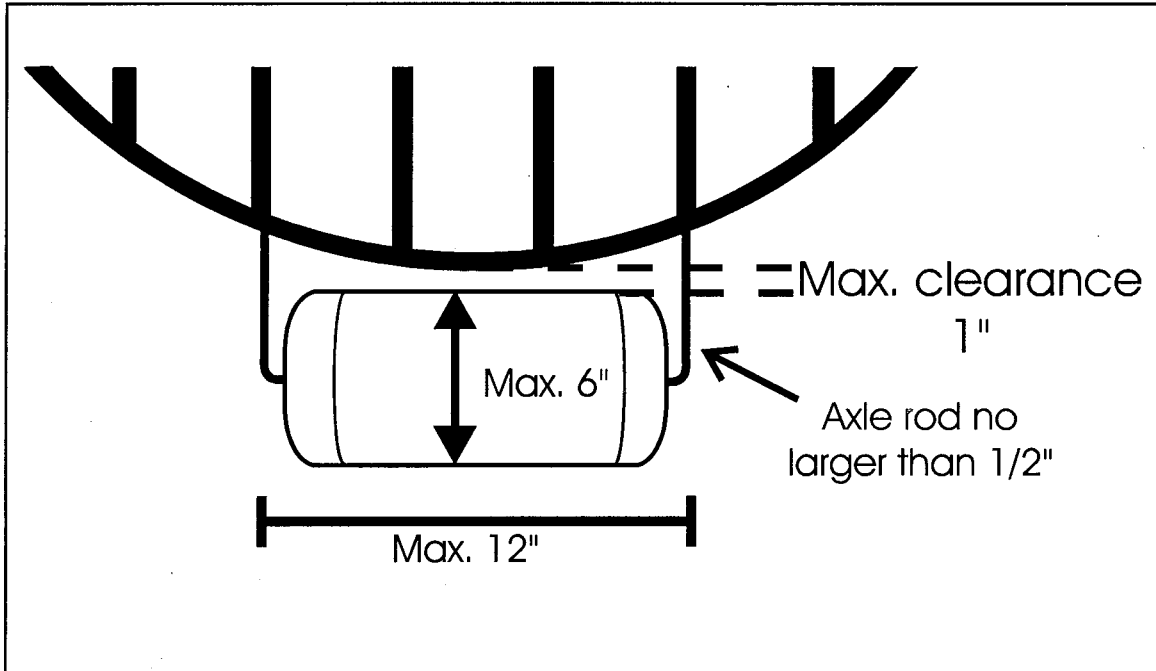

Figure 18 SPECIFICATIONS FOR SINGLE ROLLER ON AXLE ROD

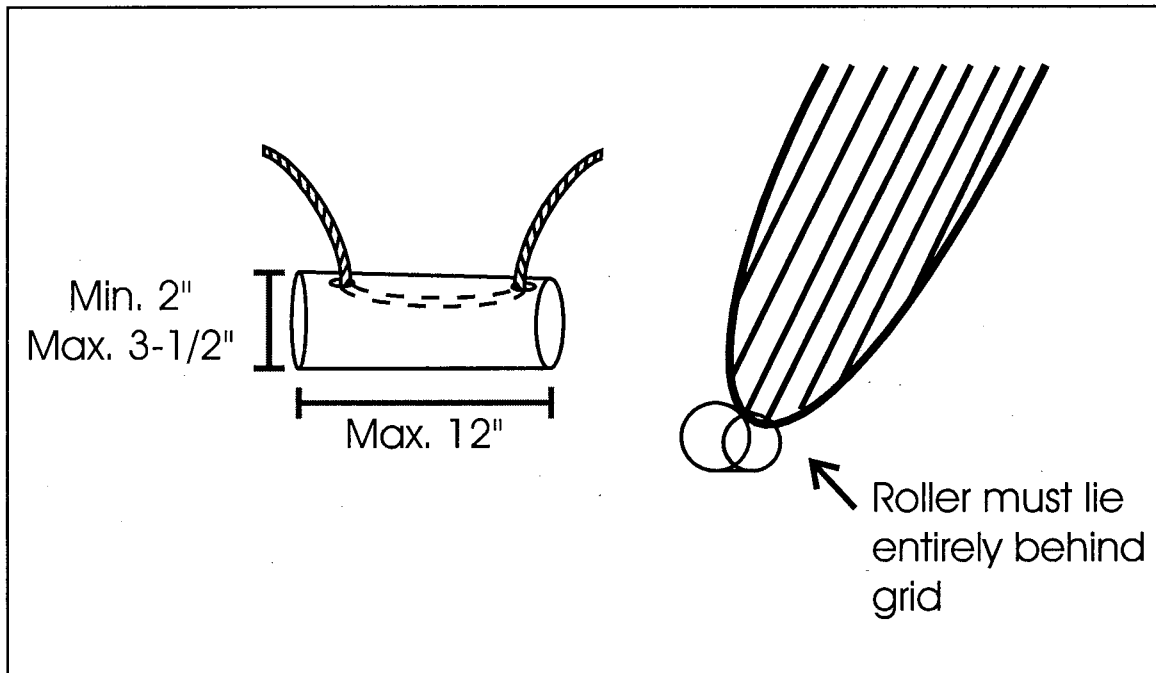

Figure 19 SPECIFICATIONS FOR SINGLE ROLLER TIED TO TED FRAME

TED REGULATION SUMMARY: ROLLER GEAR

SINGLE HARD PLASTIC ROLLER

1. Must be mounted on an axle rod, so that the roller can roll freely about the axle.
2. Roller dimension - 6-inches (15.24 cm) maximum diameter.
3. Axle rod dimension - 12-inches (30.4 cm) maximum width, no larger than 1/2-inch (1.28 cm) in diameter.
4. Roller must be attached to the TED by two support rods made from steel or aluminum rod no larger than 1/2-inch (1.28 cm) diameter.
5. Maximum clearance between the roller and the TED shall not exceed 1 inch (2.5 cm).
6. The axle rod and support rods must lie entirely behind the plane of the face of the TED grid.

SINGLE HARD PLASTIC TUBING ROLLER

1. Roller dimensions :
Maximum outside diameter 3 1/2-inches (8.0 cm).
Minimum outside diameter 2-inches (5.1cm).
Maximum width 12-inches (30.4cm).
2. Must be tied tightly to the back face of the TED grid with rope or heavy twine passed through the center of the roller tubing.
3. Roller must lie entirely behind the plane of the face of the TED grid.

LAZYLINE

One of the most frequent causes of shrimp loss with TEDs are trawl lazylines which have not been lengthened to accommodate the additional extension of the TED webbing (Figure 20). The installation of a TED into a trawl requires that the trawl lazylines be extended approximately 12-ft (3 meters). A short lazyline will cause the trawl to become distorted during the tow. Trawl distortion leads to irregular water flow through the TED and increases the possibility of shrimp loss.

Lazylines with choker straps at the tailbag can sometimes become fouled, restricting the catch and possibly resulting in shrimp loss through the TED. Use of an "elephant ear" rather than a choker strap to attach the lazyline to the tailbag can decrease the possibility of catch loss.

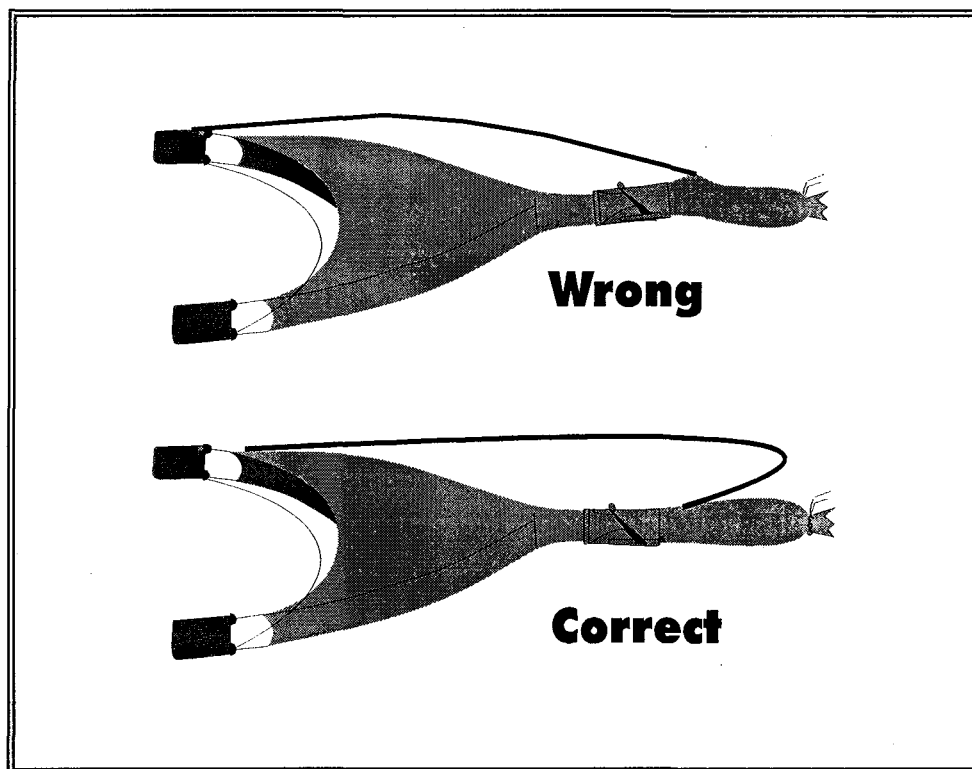

Figure 20 SHORT LAZYLINE AND TRAWL DISTORTION

When quad rigs are used, lazylines are usually bridled to allow the tailbags from both nets on the same side of the vessel to be retrieved using one line. One method of insuring that the bridle length to each tailbag is long enough is to install a "slip ring" on the inside net bridle (Figure 21). The slip ring allows the bridle to "self adjust" to the necessary length.

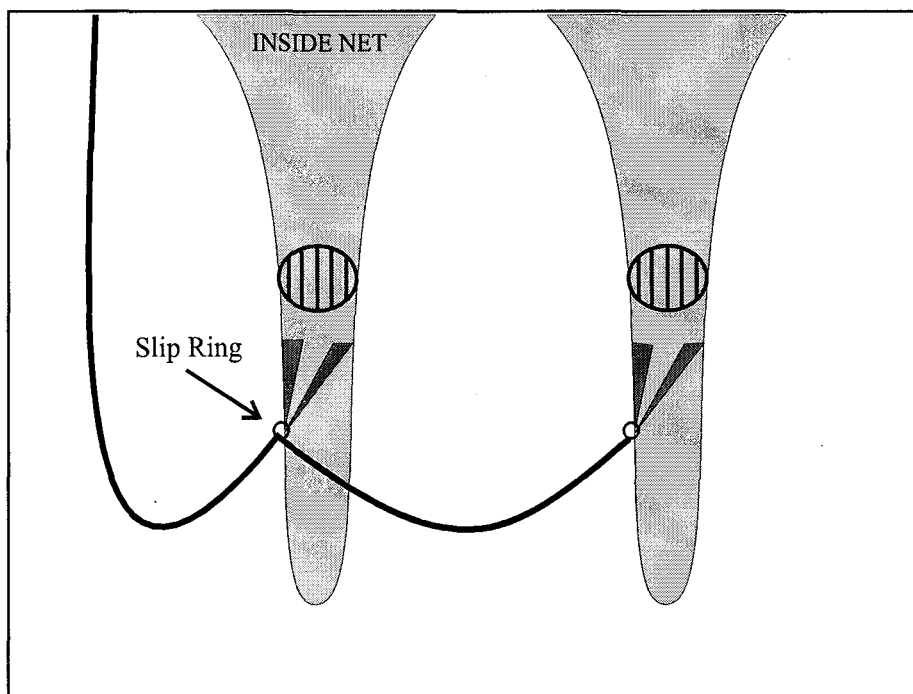

Figure 21 SLIP RING ARRANGEMENT FOR QUAD RIGS

DEPLOYMENT AND RETRIEVAL TIPS

TED handling at sea can be made easier and less trouble if the correct procedures are followed.

Before setting out, the nets should be inspected to insure that webbing ahead of the TED is not twisted. In most cases, a twist will be readily visible. Twists can be easily removed with the TED alongside of the vessel before deployment.

Once the TED is free of twists, the tailbag can be released and the vessel should idle forward. The lazylines should be allowed to freely coil off the deck. Just before dropping the doors into the water to begin the tow, make one last check for a possible twist ahead of the TED.

Increasing vessel speed before dropping the doors will cause most TEDs to ride high in the water at the surface. The webbing extension ahead of the TED will be visible, and any twists should be easily spotted. If a twist is present, the bag and TED must be brought back alongside and the twists removed. No further attention to the TED is necessary at this point and the nets can be deployed in the usual manner.

When towing, there is very little that can be done to check on TED operation. Some captains who use bottom opening TEDs feel that periodically slowing the boat to 1 knot or less for 10 seconds or so can cause any debris, that may have accumulated against the TED deflector bars, to dislodge and be discharged through the exit hole. This technique may cause problems with bogging and tangling of gear in soft or muddy bottom conditions.

When retrieving the trawl, it is important to start the haulback with the boat headed into the sea. This is especially important in rough weather and will prevent the catch in the tailbag from being washed forward through the escape hole of the TED once the TED is at the surface.

The vessel should maintain speed and direction once the trawl doors have been brought to the block. The nets and TEDs can be washed down at the surface for at least 1 minute to insure that all of the catch has been washed past

the TED. In some conditions, and with some net designs, captains advise against heavy wash-downs which can cause catch to be washed out of the TED exit hole. The length and intensity of wash-downs will be dependent on local conditions and type of gear being used.

MAINTENANCE & TROUBLESHOOTING

If a shrimp loss is suspected with a TED equipped net, check and correct the following trawl and TED components:

1. Make sure the grid is not clogged with trash and debris, if so, pull the debris out of the TED. Keep the webbing around the TED clean of any gilled fish, especially the flap and accelerator funnel.
2. Check the exit hole cover or flap for wear and a good fit. If the flap looks worn, it probably is not sealing the exit hole effectively - replace it.
3. Consider using an accelerator funnel to keep shrimp away from the exit hole. Routinely check and, if necessary, replace it when the funnel loses shape.
4. Check the bottom of the TED for chafing. If the TED is chafing, make sure it has enough flotation. The floats should not be worn out or compressed. Consider using hard plastic floats which will not compress. Remember that flotation is especially important when using a bottom opening TED to insure that debris will be excluded during the tow.
5. Check the length of the lazyline to insure it is long enough so the TED and tailbag are not distorted when towing.
6. Check the grid angle on a regular basis, especially after large catches of fish or mud. The TED should be reinstalled if the angle is above 55° or below 30°.
7. Excessive gilling of fish just ahead of the TED can indicate a twist in the TED.

8. Finally, if shrimp loss continues, you may consider changing to a different style of TED which may be better suited for the most frequently encountered fishing conditions.

OTHER REQUIREMENTS

There are additional legal requirements for installation and use of single grid TED designs including:

1. Float placement and method of attachment.
2. Position of the escape opening cut.
3. Method of grid attachment.
4. Direction of grid bars.

For specific information on legal TED requirements it is the individual shrimpers responsibility to refer to the federal TED regulations, 50 CFR parts 217,222,227 and the Federal Register for this information*

*** This booklet is provided as a problem solving guide to TED operation. Please refer to the federal TED regulations published in the Federal Register for specific information pertaining to sea turtle conservation requirements as they apply to shrimp trawling.**

SOFT TEDs

Soft TED designs, currently certified for use in the shrimp fishery, are the Morrison TED, the Taylor TED, and the Andrews TED. The Morrison and Taylor TEDs are top opening designs and the Andrews TED is a bottom opening design (Figure 22). Soft TED designs, while popular in the fleet, are more difficult to install in trawls properly and if installed incorrectly can reduce their effectiveness in releasing turtles and retaining shrimp catch. Recent testing has shown there are operational problems associated with the Morrison and Taylor designs due to the flexibility of the TED panel and the difficulty in installing these TEDs in the many different trawl designs used by shrimp fishermen. This problem is aggravated by changes that can occur to the shape of shrimp trawls when rigging is changed or fishing conditions change.

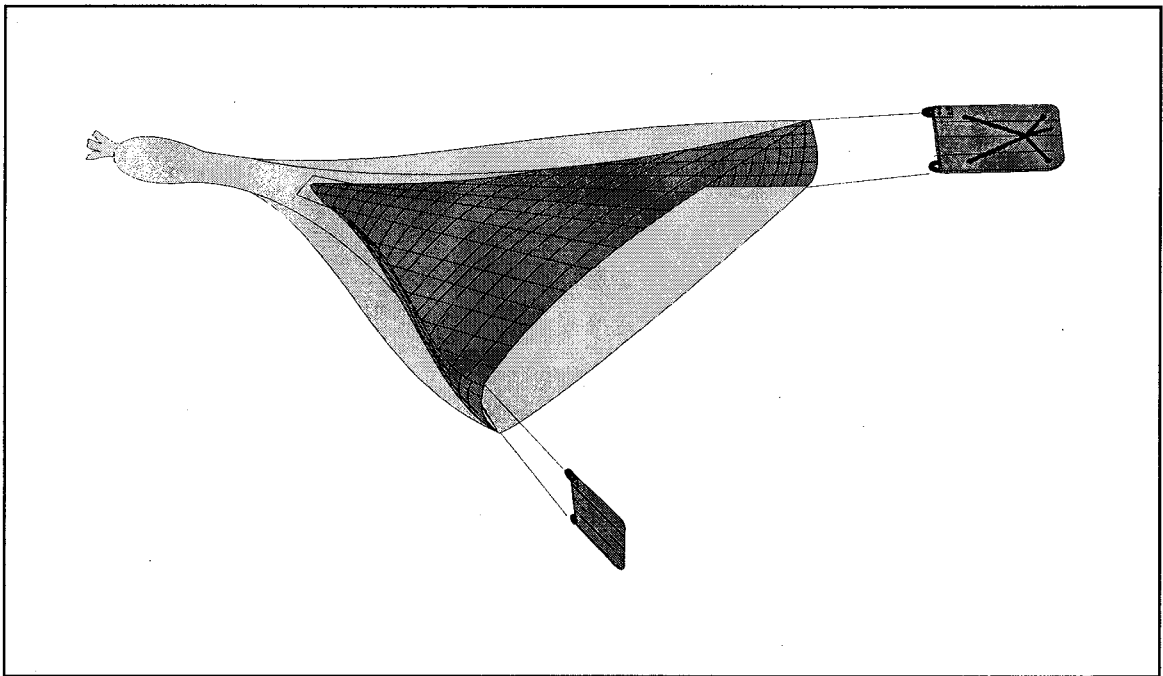

Figure 22 ANDREWS SOFT TED

While soft TEDs may function well in some fishing conditions, testing has shown that they can experience shrimp loss rates as high as 20 percent, and if installed too loose can entangle turtles. For this reason the installation, mesh size

requirements, materials, and construction requirements are very specific for each design and you will need to refer to the federal TED regulations for the specific requirements of each design.

Recent experience by shrimp fishermen has shown that Morrison TEDs do not perform well in bib trawls and should not be used in these trawls. It is recommended that the Morrison TED be used only in tapered wing flat nets and the TED be of a single panel design with the leading edge of the TED panel not extending laterally beyond the trawl wing to bottom body seam.

To insure proper operation, it is strongly recommended that soft TEDs be installed by experienced and competent net shops.

SUMMARY

With attention to materials, installation, and operation, TEDs can work well with minimum difficulty for fishermen. Many U.S. fishermen have learned that TEDs can reduce the amount of labor required to sort and clean the catch as well as improve the quality of the shrimp product. As with any new fishing technique or equipment, experience of fishermen is continuing to provide improvements in TED design and performance allowing fishermen to continue to efficiently harvest shrimp while protecting the environment.

The National Marine Fisheries Service welcomes questions regarding any of the information presented, including TED regulations. Please contact the following NMFS offices:

**United States Department of Commerce
National Marine Fisheries Service
Protected Species Management Branch
Koger Building.
9721 Executive Center Dr.
St. Petersburg, FL 33702
PH: 813-570-5312**

or

**United States Department of Commerce
National Marine Fisheries Service
Harvesting Systems Branch
P.O. Drawer 1207
Pascagoula, MS 39568-1207
PH: 601-762-4591**